

## Relationship between Antibacterial Activity and Porin Binding of Lactoferrin in *Escherichia coli* and *Salmonella typhimurium*

SMITA S. NAIDU,<sup>1</sup> ULLA SVENSSON,<sup>2</sup> ALUGUPALLI R. KISHORE,<sup>1</sup> AND A. SATYANARAYAN NAIDU<sup>1†\*</sup>

*Department of Medical Microbiology, University of Lund, Malmö General Hospital, S-214 01 Malmö,<sup>1</sup> and the Swedish Dairies Association, Research Park Ideon, S-223 70 Lund,<sup>2</sup> Sweden*

Received 29 June 1992/Accepted 10 December 1992

The effect of lactoferrin (Lf) on bacterial growth was tested by measuring conductance changes in the cultivation media by using a Malthus-AT system and was compared with the magnitude of <sup>125</sup>I-labeled Lf binding in 15 clinical isolates of *Escherichia coli*. The binding property was inversely related to the change in bacterial metabolic rate ( $r = 0.91$ ) and was directly related to the degree of bacteriostasis ( $r = 0.79$ ). The magnitude of Lf-bacterium interaction showed no correlation with the MIC of Lf. In certain strains, Lf at supraoptimal levels reduced the bacteriostatic effect. Thus, the Lf concentration in the growth media was critical for the antibacterial effect. The cell envelopes of *Salmonella typhimurium* 395MS with smooth lipopolysaccharide (LPS) and its five isogenic rough mutants revealed 38-kDa porin proteins as peroxidase-labeled-Lf-reactive components in sodium dodecyl sulfate-polyacrylamide gel electrophoresis and Western blot (ligand blot) analysis. However, in the whole cell binding assay, parent strain 395MS demonstrated a very low interaction with <sup>125</sup>I-Lf. On the other hand, Lf interaction gradually increased in correspondence with the decrease in LPS polysaccharide moiety in the isogenic rough mutants. Conductance measurement studies revealed that the low-level-Lf-binding (low-Lf-binding) strain 395MS with smooth LPS was relatively unsusceptible to Lf, while the high-Lf-binding mutant Rd was more susceptible to Lf. These data suggested a correlation between Lf binding to porins and the Lf-mediated antimicrobial effect. The polysaccharide moiety of LPS shielded porins from the Lf interaction and concomitantly decreased the antibacterial effect.

Lactoferrin (Lf) constitutes one of the major antimicrobial systems in milk and various mammalian exocrine secretions (8, 9, 11, 29, 42). An important role for Lf in nonspecific local secretory immunity at the mucosal surface has been suggested, more effectively in association with immunoglobulin A (45, 46). Lf also occurs in the specific granules and contributes to the microbicidal activity of the polymorphonuclear leukocytes (1, 10, 30). Since Lf could directly have bacteriostatic, bactericidal, and opsonic effects on bacteria, it has been regarded as one of the potential preimmune host defense systems (3, 22, 37, 42).

Lf is an iron-binding protein that reversibly binds two atoms of Fe<sup>3+</sup> in the presence of bicarbonate (17, 28). This property enables Lf to scavenge iron from the physiological milieu. Eventually, such processes may deprive iron from the microorganisms and inhibit their metabolic activities in vivo. This hypothesis provided an explanation to elucidate the bacteriostasis effect caused by apo-Lf with a variety of bacteria (39, 41, 45, 46). However, other studies have indicated that the mechanism of Lf-mediated antimicrobial action is more complex than simple iron deprivation (4, 47). The bactericidal activity was iron irreversible, and this pathway seems to require an Lf interaction with the target cell surface (2, 3, 5, 13). Furthermore, a peptic fragment from Lf without iron-binding capacity was identified as a potent bactericidal domain (43). The opsonic effect seems to

involve specific interaction of Lf with the microbial surface (22); in complement, Lf-binding receptors are present on the phagocytic cell cascade (6, 25, 50).

Our laboratory has previously demonstrated specific binding of Lf in bacteria belonging to the family *Enterobacteriaceae* and has identified porins as the Lf-binding target proteins (15, 16, 21, 35, 48). Lf-binding outer membrane proteins are a class of well-conserved molecules that form ion channels and constitute a permeability barrier against various molecules, including antibiotics, in bacteria (36). Furthermore, these outer membrane proteins serve as receptors for certain colicins and bacteriophages (7, 24). Though porins occur at a high copy number (7), the Lf-binding capacity markedly varied in these bacteria (15, 48). The lipopolysaccharide (LPS) type seemed to affect the interaction of Lf with porins in certain wild-type strains (16, 48).

This study was aimed at elucidating the effect of Lf-porin interaction on the bacterial growth. For this purpose, the Lf susceptibility patterns of different clinical isolates of *Escherichia coli* with various magnitudes of Lf-binding capacity were examined. To illustrate the extent of LPS involvement, various rough (R) mutants of *Salmonella typhimurium* with different lengths of polysaccharide moiety were tested for Lf binding and susceptibility.

### MATERIALS AND METHODS

**Bacteria.** The 15 clinical isolates of *E. coli* included in this study were from our existing strain collection, and the Lf interaction property of these strains was elucidated in an earlier study (35). A previously well-characterized *S. typh-*

\* Corresponding author.

† Present address: Dental Research Center, School of Dentistry, University of North Carolina at Chapel Hill, Chapel Hill, NC 27599-7455.

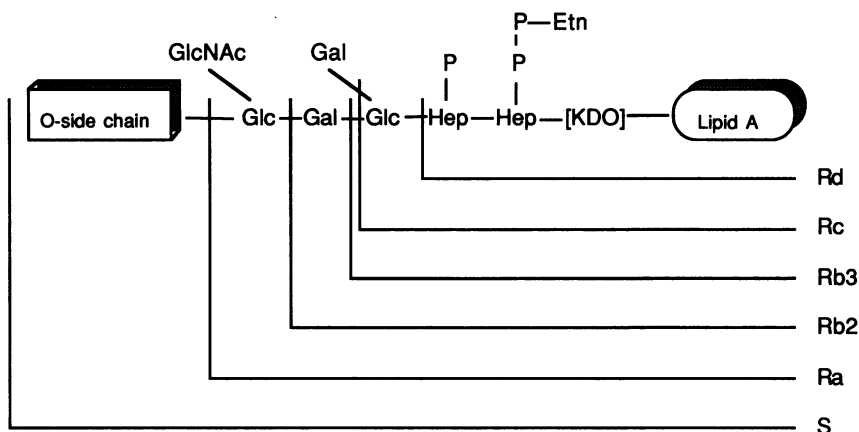

FIG. 1. Schematic representation of the chemical structure of LPS from *S. typhimurium*. Wild-type strain 395MS(S) synthesizes the entire structure, whereas various mutant strains produce the Ra to Rd chemotypes of LPS.

*imurium* strain, 395MS(S), and its isogenic R mutants with various lengths of LPS polysaccharide moiety (23) (Fig. 1) were kindly provided by O. Stendahl, Department of Medical Microbiology, Linköping University, Linköping, Sweden. Bacterial strains were stored in glycerol at  $-80^{\circ}\text{C}$ , revived on special peptone yeast extract (SPYE) agar (Malthus-AT, West Sussex, England), and subsequently cultivated in SPYE broth at  $37^{\circ}\text{C}$  for binding and antibacterial assays.

**Lf.** Bovine Lf was isolated from milk serum by an industrial-scale process (12). The homogeneity of the protein was determined by ion-exchange (Mono-Q column; Pharmacia AB, Uppsala, Sweden) and molecular-sieve (model TSKG4000SW; LKB Produkter AB, Bromma, Sweden) high-performance liquid chromatography. The iron content was estimated at approximately  $250\ \mu\text{g/g}$  of protein by using a Perkin-Elmer (model 560) atomic absorption spectrophotometer. Lf was used in its native form as isolated from the biological reservoir.

**Binding of Lf to bacteria and cell envelope (CE) proteins.** Lf was labeled with  $\text{Na}^{125}\text{I}$  (DuPont Scandinavia AB, Stockholm, Sweden) to a specific activity of  $0.16\ \text{MBq}/\mu\text{g}$  of protein by using iodobeads (Pierce Chemical Co., Rockford, Ill.) (26). The binding of  $^{125}\text{I}$ -Lf to bacterial whole cells was performed as previously described by Naidu et al. (31, 33, 34).

The interaction of horseradish peroxidase (HRPO)-labeled Lf with CE proteins of *S. typhimurium* was examined according to the method of Kishore et al. (19, 21). The boiled samples of CE were resolved by performing electrophoresis in 1-mm-thick gels at a 33-mA constant current for 70 min in a discontinuous buffer system. The stacking and separating gels contained 4 and 12.5% acrylamide, respectively. After electrophoresis, proteins in the gel were transferred to a nitrocellulose membrane (Sartorius, Göttingen, Germany) at  $0.8\ \text{mA}/\text{cm}^2$  for 1 h by using Transblot-cell equipment (Bio-Rad, Richmond, Calif.) and Western blotting (ligand blotting) was performed according to the method of Kishore et al. (20, 21). Preincubation of blots with unlabeled Lf abolished the Lf-HRPO interaction and excluded the possibility of direct HRPO binding to CE components.

**Antibacterial assay for Lf.** The effect of Lf on bacterial growth was estimated by measuring changes in conductance of the cultivation media by using a Malthus-AT system. The assay was performed with special glass tubes (10-ml volume)

containing SPYE broth without or with Lf (0.01 to 10 mg/ml). The tubes were inoculated with test strains ( $\sim 1.4 \times 10^4$  bacteria per ml) from an overnight SPYE broth culture and sealed with special screw caps fitted with platinum electrodes. The electrodes were immersed in a final volume of 3 ml of growth media, and the tubes were plugged into a Malthus electric adaptor connected to an electronic monitor and were incubated at  $37^{\circ}\text{C}$ . The metabolic activity of the bacteria was continuously measured as the rate of change in conductance (micro-Simmons [ $\mu\text{Si}$ ] per hour) of the culture media. The conductance measurements were automatically recorded by a built-in computer system equipped with a Malthus-AT laboratory program. The following definitions were used. (i) Detection time (DT) (unit, hours) was the time required to initiate detection of change in conductance, since a minimal metabolic activity was required for a detectable conductance change (i.e., sensitivity of the assay). (ii) The inability of bacteria to cause a change in conductance was considered metabolic inhibition; bacteriostasis (units, hours) was the difference in the DTs obtained with bacteria in the absence and presence of Lf. (iii) The MIC (units, milligrams per milliliter) was the smallest amount of Lf required to elicit a complete inhibition of bacterial growth at the time point when the metabolism of the control (bacteria grown without Lf) reached stationary phase.

**Data analysis.** Correlations between binding and parameters of antimicrobial activity were made by linear regression analysis.

## RESULTS

Fifteen clinical isolates of *E. coli* showing different magnitudes of  $^{125}\text{I}$ -labeled Lf binding were examined for growth in SPYE media with or without Lf (Table 1). Lf at a concentration of 1 mg/ml caused bacteriostasis in all strains, with a mean DT increase of 4.1 h (minimum, 0.6 h; maximum, 13.8 h). At an Lf concentration of 2 mg/ml, the DT was increased in nine strains and unaffected or slightly decreased in six strains, compared with the DTs at an Lf concentration of 1 mg/ml. The kinetics of bacterial growth were measured as change in conductance per hour, and in the presence of 1 and 2 mg of Lf per ml the mean rates were 95.3 and 68.9  $\mu\text{Si}/\text{h}$ , respectively. Finally, the total change in conductance of growth media during a period of 20 h was also determined. A majority of low-level binders (low binders) (<20% Lf

TABLE 1. Lf binding<sup>a</sup> and growth<sup>b</sup> of 15 clinical isolates of *E. coli* in SPYE media

Strain	% Binding	DT (h) with:			Conductance ( $\mu$ Si)					
					Change/h with:			Change in 20 h with:		
		Lf-0	Lf-1	Lf-2	Lf-0	Lf-1	Lf-2	Lf-0	Lf-1	Lf-2
E450	2 $\pm$ 1	3.6	6.7	6.2	377	258	217	619	555	516
E452	2 $\pm$ 1	3.9	6.8	8.6	236	171	117	606	632	555
E446	3 $\pm$ 1	4.1	5.5	5.9	322	235	202	645	632	606
E453	3 $\pm$ 1	6.2	10.0	7.8	264	184	119	632	594	581
E519	9 $\pm$ 1	6.2	9.8	11.3	240	110	105	503	413	387
E50	13 $\pm$ 2	5.4	6.1	7.4	263	139	97	594	529	516
E520	16 $\pm$ 3	6.6	11.5	10.3	126	30	21	555	284	206
E518	18 $\pm$ 3	6.8	12.0	13.6	129	35	29	542	284	194
E71	22 $\pm$ 2	4.3	6.8	9.0	253	106	104	542	477	400
E355	23 $\pm$ 3	6.2	>20	>20	44	0	0	361	0	0
E408	24 $\pm$ 1	7.0	7.6	>20	64	31	0	361	374	0
E354	24 $\pm$ 2	6.6	8.3	12.3	157	65	12	722	568	103
E412	25 $\pm$ 4	6.5	>20	>20	116	0	0	374	0	0
E413	27 $\pm$ 3	5.6	7.4	13.2	83	39	10	464	374	64
E386	28 $\pm$ 4	7.9	11.5	>20	47	26	0	387	181	0

<sup>a</sup> Bacteria grown in SPYE broth at 37°C for 20 h were harvested and examined for interaction with <sup>125</sup>I-labeled Lf as previously described (31, 33, 34) under comparable test conditions. Binding is expressed as the percentage of total labeled protein added (mean  $\pm$  standard deviation).

<sup>b</sup> A comparable inoculum, i.e.,  $1.4 \times 10^4$  bacteria, was added to SPYE media containing Lf at a final concentration of 1 mg/ml (Lf-1) or 2 mg/ml (Lf-2), and media without Lf (Lf-0) served as a control. Bacterial growth was measured (as change in the conductance of the media) at 37°C during a period of 20 h, using Malthus equipment as described in Materials and Methods.

binding) recovered from the Lf-mediated bacteriostasis, and Lf slightly affected the growth of these bacteria during the 20-h incubation. However, the high binders (except strain E71) failed to recover from the antibacterial effect of Lf during this incubation period.

Data from Table 1 were further analyzed to find a relationship between the magnitude of Lf binding and the antibacterial action of Lf at a 1-mg/ml concentration (Fig. 2). The effect of Lf on the bacterial metabolic rate (expressed as a percentage, considering the rate of change in the conductance of the control to be 100% metabolism) demonstrated an inverse correlation ( $r = 0.91$ ) with the magnitude of Lf binding to bacteria. The three strains that showed total metabolic inhibition with Lf also demonstrated a high level of binding to <sup>125</sup>I-labeled Lf (>22%). The Lf-mediated bacteriostasis, i.e., prolongation of DT compared with that of

the control, also showed a correlation ( $r = 0.79$ ) with the Lf interaction property of the bacteria. Complete metabolic inhibition could not be achieved, in particular, among low-binding strains. Thus, low-binding strain E446 demonstrated a diminished metabolism and no total inhibition was achieved at an elevated Lf concentration. On the other hand, the metabolism of high-binding strain E386 was totally ceased at an Lf concentration of 0.7 mg/ml (Fig. 3). However, no correlation was found between the MIC determinations and Lf-binding properties of the 15 *E. coli* strains tested (Fig. 2).

The extent of LPS involvement in Lf binding to bacteria was tested by using R mutants of *S. typhimurium*. Sodium dodecyl sulfate-polyacrylamide gel electrophoresis (SDS-PAGE) and Western blot analysis (using HRPO-labeled Lf) of bacterial CE revealed Lf-binding proteins at approxi-

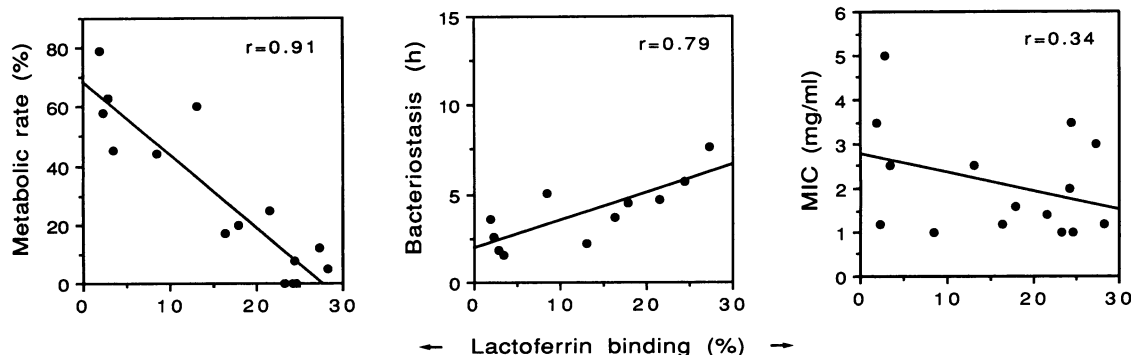

FIG. 2. Relationship between the magnitude of Lf binding and the antibacterial action of Lf in 15 clinical isolates of *E. coli*. Correlations between parameters were made by linear regression analysis. The metabolic rate in the presence of Lf (1 mg/ml) was expressed as a relative percentage, considering the change in the conductance rate of the control (without Lf) to be 100%. Bacteriostasis was estimated as the DT difference between bacterial growth in media with Lf (1 mg/ml) and the control. Three strains that demonstrated complete growth inhibition and one strain that showed growth enhancement at an Lf concentration of 1 mg/ml were excluded during analysis of the bacteriostasis parameter. For MIC determinations, bacteria were grown in the presence of 15 different concentrations of Lf within a range of 0.01 to 10 mg/ml. The smallest amount of Lf that caused complete inhibition of bacterial growth at the time point when the metabolism of the control reached stationary phase was considered to be the MIC.

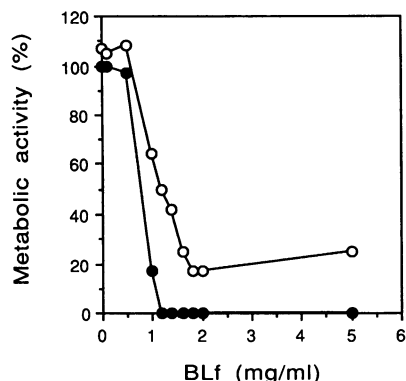

FIG. 3. Inhibition of bacterial growth as a function of Lf concentration in high-binding strain E386 (●) and low-binding strain E446 (○).

mately a 38-kDa position in the smooth parent 395MS(S) and also in the five isogenic R mutants (Fig. 4). The 38-kDa Lf-reactive bands demonstrated a heat-modifiable nature and anti-porin immunoreactivity (data not shown) similar to those of the *S. typhimurium* type strain, ATCC 13311 (21). However, in the whole cell binding assay, the smooth parent strain 395MS(S) demonstrated low binding (10%) and differed from its isogenic R mutants. The Lf interaction capacity gradually increased to a maximum of fourfold in the corresponding R mutants with various lengths of LPS polysaccharide moiety (Table 2). The conductance measurement studies revealed that the low-Lf-binding smooth parent strain was less inhibited by Lf (0.4- and 1.3-h stasis with 1 and 5 mg of Lf per ml, respectively). On the other hand, the high (44%)-Lf-binding mutant Rd was more susceptible to the antibacterial action of Lf (0.8 and 2.0 h with 1 and 5 mg of Lf per ml, respectively) (Fig. 5). The bacterial metabolic rate was slightly affected at 1 mg of Lf per ml and diminished about 50% at 5 mg of Lf per ml in the mutant Rd compared with the smooth parent.

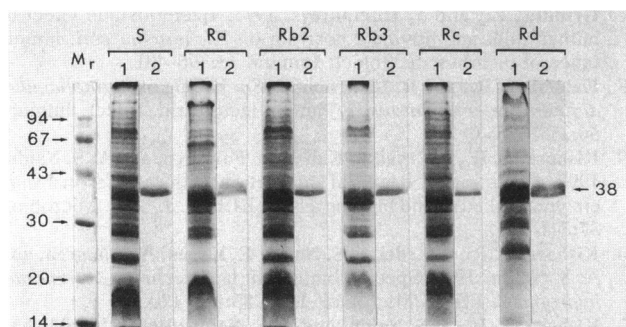

FIG. 4. Demonstration of Lf-binding proteins in the boiled CE preparation of *S. typhimurium* 395MS(S) and its isogenic R mutants with various lengths of LPS polysaccharide moiety (see Fig. 1). The bacterial CE was isolated and analyzed by SDS-PAGE and Western blotting (ligand blotting) as described by Kishore et al. (21). Coomassie-brilliant-blue-R-stained gels (lanes 1) and their corresponding blots probed with HRPO-labeled Lf (lanes 2) are shown. The molecular weight standards are indicated with arrows at the left, and the reactive band with its estimated molecular mass is indicated with an arrow at the right.

TABLE 2. Lf binding and antimicrobial activity in *S. typhimurium* 395MS(S) and its LPS-deficient isogenic mutants<sup>a</sup>

LPS type <sup>b</sup>	Binding <sup>c</sup> (%)	Bacteriostasis <sup>d</sup> (h) with:		Metabolic rate <sup>e</sup> (%) with:	
		Lf-1	Lf-5	Lf-1	Lf-5
S	10 ± 1	0.4 ± 0.2	1.3 ± 0.2	100 ± 8	76 ± 7
Ra	17 ± 2	0.5 ± 0.5	1.3 ± 0.3	96 ± 14	75 ± 13
Rb2	24 ± 3	0.3 ± 0.2	1.0 ± 0.2	91 ± 9	86 ± 11
Rb3	30 ± 2	0.2 ± 0.2	0.9 ± 0.2	101 ± 8	62 ± 7
Rc	34 ± 4	0.6 ± 0.2	0.8 ± 0.3	107 ± 4	82 ± 5
Rd	44 ± 4	0.8 ± 0.1	2.0 ± 0.1	98 ± 5	36 ± 3

<sup>a</sup> Bacterial growth was tested at an Lf concentration of 1 mg/ml (Lf-1) or 5 mg/ml (Lf-5) at 37°C for 24 h; media without Lf served as a control. Mean values and standard deviations are based on four experiments.

<sup>b</sup> Designated according to the scheme shown in Fig. 1.

<sup>c</sup> Binding is expressed as the percentage of total labeled protein added.

<sup>d</sup> DT difference between growth in media with Lf and the control.

<sup>e</sup> Expressed as the relative percentage, considering the change in the conductance rate of the control to be 100%.

DISCUSSION

Studies with 15 clinical isolates of *E. coli* with different Lf-binding capacities revealed that the concentration of Lf in growth media was a critical factor for the antibacterial effect. Lf at a supraoptimal concentration showed either a reduced or no additional effect in certain strains. Excess of free ligand in the media may affect the equilibrium of a receptor-ligand interaction (44). The binding of Lf to porins was reversible and had a low affinity (20, 21, 35, 48). Thus, at a supraoptimal concentration, free Lf in the media could

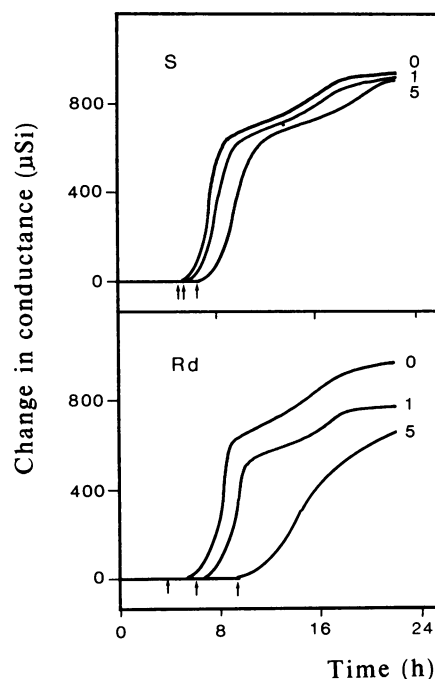

FIG. 5. Growth of *S. typhimurium* 395MS(S) (S; parent with smooth LPS) and its isogenic mutant Rd (with R LPS) in SPYE broth with Lf (1 and 5 mg/ml) or without Lf (0). The bacterial metabolism at 37°C was measured for 24 h as the change in conductance of growth media by using a Malthus-AT system as described in Materials and Methods.

possibly decrease specific interaction and reduce the antimicrobial activity of Lf. Under such conditions, Lf failed to elicit a total inhibitory effect on low binders. Accordingly, the MIC did not correlate with the bacterium binding property of Lf.

The magnitude of the Lf-bacterium interaction was inversely related to the change in the metabolic rate of the bacteria and was directly related to the degree of bacteriostasis. The metabolic suppression did not seem to be iron dependent, since an Lf peptide fragment without iron-chelating capacity showed both porin binding and metabolic inhibitory capacity (32). Interestingly, another peptide, generated by pepsin hydrolysis at acidic pH according to the method of Saito et al. (43), showed antimicrobial activity but failed to inhibit  $^{125}\text{I}$ -Lf binding to *E. coli* and 10 other different species of the family *Enterobacteriaceae*. Furthermore, the antibacterial activity of the latter peptide was highly vulnerable to changes in the growth conditions (32). In *Actinobacillus actinomycetemcomitans*, the growth temperature increase of 2°C (37 to 39°C) markedly enhanced the susceptibility of the bacterium to Lf (18). Fatty acid composition and bacterial membrane permeability are highly prone to temperature-induced effects (27). Thus, our findings on Lf-porin interaction in members of the family *Enterobacteriaceae* and Lf-mediated enhancement in antibiotic susceptibility of *S. typhimurium* (15, 21, 48) suggest that Lf could damage the outer membrane of gram-negative bacteria and cause permeability alterations as proposed by Ellison and coworkers (14). It also seems possible that Lf might affect certain cellular pathways in bacteria. Arnold and coworkers (4) demonstrated that Lf could inhibit glucose uptake and metabolism in *Streptococcus mutans*. Peterson and Alderete (38) showed that the specific binding of Lf to *Trichomonas vaginalis* caused a sixfold increase in the pyruvate/ferredoxin oxidoreductase activity, an enzyme involved in energy metabolism.

For certain members of the family *Enterobacteriaceae*, Lf binding to strains with smooth LPS was low or negligible compared with that of their isogenic R mutants with a high Lf-binding capacity (16, 48). Our study with the isogenic R mutants of *S. typhimurium* suggested that the magnitude of Lf binding to whole cells was inversely related to the length of the LPS polysaccharide moiety. Accordingly, the low-Lf-binding smooth parent was less susceptible to Lf, and at corresponding conditions the growth of LPS-deficient mutant Rd was inhibited by 50%. By analogy, such LPS polysaccharide involvement in the blockade of certain colicin and bacteriophage interaction with porin targets was previously reported (49, 51). *S. typhimurium* could also demonstrate an increased susceptibility to magainin 2 (a small cationic antimicrobial peptide) with a gradual decrease in the length of the LPS polysaccharide moiety (40).

In conclusion, our data suggested a correlation between Lf binding to porins and the Lf-mediated antimicrobial effect. Shielding of porins by the polysaccharide moiety of LPS could block the bacterial interaction with Lf and decrease the antibacterial effect.

#### ACKNOWLEDGMENTS

This work received support from the SMR, the Swedish Dairies Association; Semper AB; and STU, the Swedish Biotechnology Board.

#### REFERENCES

- Ambruso, D. R., and R. B. Johnston, Jr. 1981. Lactoferrin enhances hydroxylradical production by human neutrophils, neutrophil particulate fractions, and an enzyme generating system. *J. Clin. Invest.* **67**:352-360.
- Arnold, R. R., M. Brewer, and J. J. Gauthier. 1980. Bactericidal activity of human lactoferrin: sensitivity of a variety of microorganisms. *Infect. Immun.* **28**:893-898.
- Arnold, R. R., M. F. Cole, and J. R. McGhee. 1977. A bactericidal effect for human lactoferrin. *Science* **197**:263-265.
- Arnold, R. R., J. E. Russell, W. J. Champion, M. Brewer, and J. J. Gauthier. 1982. Bactericidal activity of human lactoferrin: differentiation from the stasis of iron deprivation. *Infect. Immun.* **35**:792-799.
- Arnold, R. R., J. E. Russell, W. J. Champion, and J. J. Gauthier. 1981. Bactericidal activity of human lactoferrin: influence of physical conditions and metabolic state of the target microorganism. *Infect. Immun.* **32**:655-660.
- Bennet, R. M., and J. Davis. 1981. Lactoferrin binding to human peripheral blood cells: an interaction with a B-enriched population of lymphocytes and subpopulation of adherent mononuclear cells. *J. Immunol.* **127**:1211-1216.
- Benz, R. 1988. Structure and function of porins from gram-negative bacteria. *Annu. Rev. Microbiol.* **42**:359-393.
- Brock, J. H. 1980. Lactoferrin in human milk: its role in iron absorption and protection against enteric infection in the newborn infant. *Arch. Dis. Child.* **55**:417-421.
- Bullen, C. L., and A. T. Willis. 1971. Resistance of the breast-fed infant to gastroenteritis. *Br. Med. J.* **3**:338-343.
- Bullen, J. J., and J. A. Armstrong. 1979. The role of lactoferrin in the bactericidal function of polymorphonuclear leucocytes. *Immunology* **36**:781-791.
- Bullen, J. J., H. J. Rogers, and L. Leigh. 1972. Iron-binding proteins in milk and resistance to *Escherichia coli* infections in infants. *Br. Med. J.* **1**:69-75.
- Burling, H. 1989. Process for extracting pure fractions of lactoperoxidase and lactoferrin from milk serum. PCT Int. patent application WO89/04608A1.
- Dalamastri, C., P. Valenti, P. Visca, P. Vittorioso, and N. Orsi. 1988. Enhanced antimicrobial activity of lactoferrin by binding to the bacterial surface. *Microbiologica* **11**:225-230.
- Ellison, R. T., III, T. J. Giehl, and F. M. LaForce. 1988. Damage of the outer membrane of enteric gram-negative bacteria by lactoferrin and transferrin. *Infect. Immun.* **56**:2774-2781.
- Erdei, J., A. Forsgren, and A. S. Naidu. Lactoferrin binds to porins OmpC and OmpF in *Escherichia coli*. Submitted for publication.
- Gadó, I., J. Erdei, V. G. Laszlo, J. Pászti, É. Cziráok, T. Kontrohr, I. Tóth, A. Forsgren, and A. S. Naidu. 1991. Correlation between human lactoferrin binding and colicin susceptibility in *Escherichia coli*. *Antimicrob. Agents Chemother.* **35**:2538-2543.
- Griffiths, E., and J. Humphreys. 1977. Bacteriostatic effect of human milk and bovine colostrum on *Escherichia coli*: importance of bicarbonate. *Infect. Immun.* **15**:396-401.
- Kalmar, J. R., and R. R. Arnold. 1988. Killing of *Actinobacillus actinomycetemcomitans* by human lactoferrin. *Infect. Immun.* **56**:2552-2557.
- Kishore, A. R., J. Erdei, S. Kalfas, A. Forsgren, and A. S. Naidu. 1992. Detection of bacterial interaction with lactoferrin by an enzyme-linked ligand binding assay (ELBA). *J. Med. Microbiol.* **37**:341-345.
- Kishore, A. R., J. Erdei, S. S. Naidu, E. Falsen, A. Forsgren, and A. S. Naidu. 1991. Specific binding of lactoferrin to *Aeromonas hydrophila*. *FEMS Microbiol. Lett.* **83**:115-120.
- Kishore, A. R., S. S. Naidu, and A. S. Naidu. 1992. Unpublished data.
- Lima, M. F., and F. Kierszenbaum. 1985. Lactoferrin effects on phagocytic cell function. I. Increased uptake and killing of an intracellular parasite by murine macrophages and human monocytes. *J. Immunol.* **134**:4176-4183.
- Lindberg, A. A., and T. Holme. 1968. Immunochemical studies on cell wall polysaccharide of rough mutants of *Salmonella typhimurium*. *J. Gen. Microbiol.* **52**:55-65.
- Lugtenberg, B., and L. van Alphen. 1983. Molecular architecture and functioning of the outer membrane of *Escherichia coli*

- and other gram-negative bacteria. *Biochim. Biophys. Acta* **737**:51–115.
25. Maneva, A. I., L. M. Sirakov, and V. V. Manev. 1983. Lactoferrin binding to neutrophilic polymorphonuclear leukocytes. *Int. J. Biochem.* **15**:981–984.
  26. Markwell, M. A. K. 1982. A new solid state reagent to iodinate proteins. *Anal. Biochem.* **125**:427–432.
  27. Marr, A. G., and J. L. Ingraham. 1962. Effect of temperature on the composition of fatty acids in *Escherichia coli*. *J. Bacteriol.* **84**:1260–1267.
  28. Masson, P. L., and J. F. Heremans. 1968. Metal-combining properties of human lactoferrin (red milk protein). I. The involvement of bicarbonate in the reaction. *Eur. J. Biochem.* **6**:579–584.
  29. Masson, P. L., J. F. Heremans, and C. Dive. 1966. An iron-binding protein common to many external secretions. *Clin. Chim. Acta* **14**:735–739.
  30. Masson, P. L., J. F. Heremans, and E. Schonne. 1969. Lactoferrin, an iron-binding protein in neutrophilic leucocytes. *J. Exp. Med.* **130**:643–658.
  31. Naidu, A. S., M. Andersson, and A. Forsgren. 1992. Identification of a human lactoferrin-binding protein in *Staphylococcus aureus*. *J. Med. Microbiol.* **36**:177–183.
  32. Naidu, A. S., and J. Erdei. Unpublished data.
  33. Naidu, A. S., J. Miedzobrodzki, M. Andersson, L.-E. Nilsson, A. Forsgren, and J. L. Watts. 1990. Bovine lactoferrin binding to six species of coagulase-negative staphylococci isolated from bovine intramammary infections. *J. Clin. Microbiol.* **28**:2312–2319.
  34. Naidu, A. S., J. Miedzobrodzki, J. M. Musser, V. T. Rosdahl, S. Å. Hedström, and A. Forsgren. 1990. Human lactoferrin binding in clinical isolates of *Staphylococcus aureus*. *J. Med. Microbiol.* **34**:323–328.
  35. Naidu, S. S., J. Erdei, É. Cziráok, S. Kalfas, I. Gadó, A. Thorén, A. Forsgren, and A. S. Naidu. 1991. Specific binding of lactoferrin to *Escherichia coli* isolated from human intestinal infections. *APMIS* **99**:1142–1150.
  36. Nikaido, H., and M. Vaara. 1985. Molecular basis of bacterial outer membrane permeability. *Microbiol. Rev.* **49**:1–32.
  37. Oram, J. D., and B. Reiter. 1968. Inhibition of bacteria by lactoferrin and other iron-chelating agents. *Biochim. Biophys. Acta* **170**:351–365.
  38. Peterson, K. M., and J. F. Alderete. 1984. Iron uptake and increased intracellular enzyme activity follow host lactoferrin binding by *Trichomonas vaginalis* receptors. *J. Exp. Med.* **160**:398–410.
  39. Rainard, P. 1986. Bacteriostasis of *Escherichia coli* by bovine lactoferrin, transferrin and immunoglobulins (IgG1, IgG2, IgM) acting alone or in combinations. *Vet. Microbiol.* **11**:103–115.
  40. Rana, F. R., E. A. Macias, C. M. Sultany, M. C. Modzrakowski, and J. Blazyk. 1991. Interactions between magainin 2 and *Salmonella typhimurium* outer membranes: effect of lipopolysaccharide structure. *Biochemistry* **30**:5858–5866.
  41. Reiter, B., J. H. Brock, and E. D. Steel. 1975. Inhibition of *Escherichia coli* by bovine colostrum and post-colostral milk. II. The bacteriostatic effect of lactoferrin on a serum-susceptible and serum-resistant strain of *E. coli*. *Immunology* **28**:83–95.
  42. Reiter, B., and J. D. Oram. 1967. Bacterial inhibitors in milk and other biological fluids. *Nature (London)* **216**:328–330.
  43. Saito, H., H. Miyakawa, Y. Tamura, S. Shimamura, and M. Tomita. 1991. Potent bactericidal activity of bovine lactoferrin hydrolysate by heat treatment at acidic pH. *J. Dairy Sci.* **74**:3724–3730.
  44. Scatchard, G. 1949. Attraction of proteins for small molecules and ions. *Ann. N.Y. Acad. Sci.* **51**:660–672.
  45. Spik, G., A. Cheron, J. Montreuil, and J. M. Dolby. 1978. Bacteriostasis of milk-sensitive strains of *Escherichia coli* by immunoglobulins and iron-binding proteins in association. *Immunology* **35**:663–671.
  46. Stephens, S., J. M. Dolby, J. Montreuil, and G. Spik. 1980. Differences in inhibition of the growth of commensal and enteropathogenic strains of *Escherichia coli* by lactotransferrin and secretory immunoglobulin A isolated from human milk. *Immunology* **41**:597–603.
  47. Stuart, J., S. Norrel, and J. P. Harrington. 1984. Kinetic effect of human lactoferrin on the growth of *Escherichia coli* O111. *Int. J. Biochem.* **16**:1043–1047.
  48. Tigyi, Z., A. R. Kishore, J. Mæland, A. Forsgren, and A. S. Naidu. 1992. Lactoferrin-binding proteins in *Shigella flexneri*. *Infect. Immun.* **60**:2619–2626.
  49. van der Ley, P., P. de Graaff, and J. Tommassen. 1986. Shielding of *Escherichia coli* outer membrane proteins as receptors for bacteriophages and colicins by O-antigenic chains of lipopolysaccharide. *J. Bacteriol.* **168**:449–451.
  50. van Snick, J. L., and P. L. Masson. 1976. The binding of human lactoferrin to mouse peritoneal cells. *J. Exp. Med.* **144**:1568–1580.
  51. Yu, F., and S. Mizushima. 1982. Roles of lipopolysaccharide and outer membrane protein OmpC of *Escherichia coli* K-12 in the receptor function for bacteriophage T4. *J. Bacteriol.* **151**:718–722.