

or from hypersensitivity reactions are worth taking as an alternative to gas gangrene, and giving penicillin prophylaxis to the small number of patients at serious risk would have a negligible effect on the proportion of patients who receive antibiotics, which is at present at least 30% of all persons admitted to hospital.

Outbreaks of Clostridial Infection

No outbreak of postoperative clostridial infection was observed in Britain during the two years 1966–8, but groups of associated cases may appear, though very rarely. For understandable reasons they are seldom reported in the medical literature. I have heard of four in the past 25 years, and had the opportunity of investigating one personally.

In two weeks four patients undergoing orthopaedic surgery developed gas gangrene. All the operations had been performed by one surgical team, but no cases followed operations performed during the same period and in the same operating-theatre by a second orthopaedic surgeon, who gave prophylactic penicillin to all his patients. The investigation revealed two further significant points. Firstly, the theatre was adequately ventilated but there were defects in the loading of a dressings autoclave so serious that clostridial spores might easily have survived in heavily contaminated material. Secondly, a patient with gas gangrene after a road accident was under treatment in the hospital. He was taken to the operating-theatre three times, and on each occasion a case of gas gangrene developed in a patient operated on within the next 24 hours.

It is clear that under normal conditions the risk to other patients of taking a patient with gas gangrene to the operating-theatre is not great. Many of the patients with gas gangrene in the present survey had amputations and none caused secondary cases. Some contamination with clostridia of instruments and materials in operating-theatres must be relatively common—for instance, in the course of operations on the bowel. Nevertheless, it is possible that the removal of

exudate-soaked dressings from a case of gas gangrene may result in a heavy and widespread contamination of objects in the theatre. This seldom appears to cause trouble under normal circumstances, but might lead to a disaster if there is a concomitant sterilizer failure or grossly defective ventilation of the theatre. This suggests that particularly rigid precautions are desirable in operating-theatres in hospitals with hyperbaric oxygen units.

I wish to thank the many hospital pathologists and surgeons who provided the information on which this report is based.

REFERENCES

- Ayliffe, G. A. J., and Lowbury, E. J. L. (1969). *British Medical Journal*, **2**, 333.
- Bornstein, D. L., Weinberg, A. N., Swartz, M. N., and Kunz, L. J. (1964). *Medicine*, **43**, 207.
- Brummelkamp, W. H. (1964–5). *Annals of the New York Academy of Science*, **117**, 689.
- Colwell, F. G., Sullivan, J., Shuman, H. H., and Cohen, J. R. (1960). *New England Journal of Medicine*, **262**, 618.
- Goldberg, N. M., and Rifkind, D. (1965). *Archives of Internal Medicine*, **115**, 421.
- Gye, R., Rountree, P. M., and Loewenthal, J. (1961). *Medical Journal of Australia*, **1**, 761.
- Hitchcock, C. R., Haglin, J. J., and Arnar, O. (1967). *Surgery*, **62**, 759.
- Johnstone, F. R. C. (1963). *Surgery, Gynecology and Obstetrics*, **116**, 1.
- Johnstone, F. R. C., and Cockcroft, W. H. (1968). *Lancet*, **1**, 660.
- Lowbury, E. J. L., and Lilly, H. A. (1958). *Journal of Hygiene*, **56**, 169.
- Lowbury, E. J. L., Lilly, H. A., and Bull, J. P. (1964). *British Medical Journal*, **2**, 531.
- Lowry, K. F., and Curtis, G. M. (1947). *American Journal of Surgery*, **74**, 752.
- Millar, W. M. (1932). *Surgery, Gynecology and Obstetrics*, **54**, 232.
- North, J. P. (1947). *Surgery*, **21**, 364.
- Russell, J. A., and Taylor, J. C. (1963). *British Journal of Surgery*, **50**, 434.
- Shapiro, B., Rohman, M., and Cooper, P. (1963). *Annals of Surgery*, **158**, 27.
- Taylor, G. W. (1960). *British Medical Bulletin*, **16**, 51.
- Traub, W. H., and Sherris, J. C. (1968). *Chemotherapy*, **13**, 303.
- Trippel, O. H., Ruggie, A. N., Staley, C. J., and Van Elk, J. (1967). *Surgical Clinics of North America*, **47**, 17.
- Willis, A. T., and Jacobs, S. I. (1964). *Journal of Pathology and Bacteriology*, **88**, 312.

Control of Sodium Reabsorption*

H. E. DE WARDENER,† M.D., F.R.C.P.

British Medical Journal, 1969, **3**, 676–683

Hormonal Control of Tubular Sodium Reabsorption

It is well established that steroids, particularly aldosterone, have a powerful effect on sodium reabsorption in the distal tubule.¹²² It is still a matter of some speculation whether another hormone controls sodium reabsorption in the proximal tubule. Most of the evidence which suggests the presence of such a hormone has been obtained in experiments in which the fluid volume of an animal has been expanded with saline, plasma, or blood.

Escape Phenomenon

The first suspicions that there might be some hormonal control of sodium reabsorption other than by aldosterone were aroused by the finding that when the extracellular fluid volume is expanded by the continuous administration of deoxycortone

acetate, fludrocortisone, or aldosterone there is an initial diminution of sodium excretion followed within a few days by a rise in sodium excretion to control levels.^{2 98 112} This is often referred to as the "sodium escape phenomenon." Smith¹⁰³ suggested that this phenomenon was due to a circulating substance which he named a natriuretic hormone X. Nevertheless, the demonstration by Davies and Shock²⁹ that the standard deviation of individual determinations of inulin clearance from the mean of a series was 5–10% was sufficient to deter most workers from accepting the sodium escape phenomenon as anything but another demonstration that sodium excretion was controlled by small changes in glomerular filtration rate,¹²³ even when the changes in filtration were so small that they were undetectable.

Effect of Intravenous Saline

The point was not resolved until de Wardener, Mills, Clapham, and Hayter¹²¹ demonstrated that in dogs receiving large amounts of salt-retaining steroids and vasopressin an infusion of saline causes a rise in urinary sodium excretion even

* Conclusion of the Oliver-Sharpey lecture given at the Royal College of Physicians of London on 30 April 1969. Part I appeared in last week's issue.

† Professor of Medicine, Charing Cross Hospital Medical School, Fulham Hospital, London W.6.

when the glomerular filtration rate is deliberately lowered. A balloon was placed in the thoracic aorta of an anaesthetized dog. The balloon was inflated when the intravenous infusion was begun. The abdominal aortic pressure fell to around 80 mm. Hg and the filtration rate by about 30 ml./min. (Fig. 12).

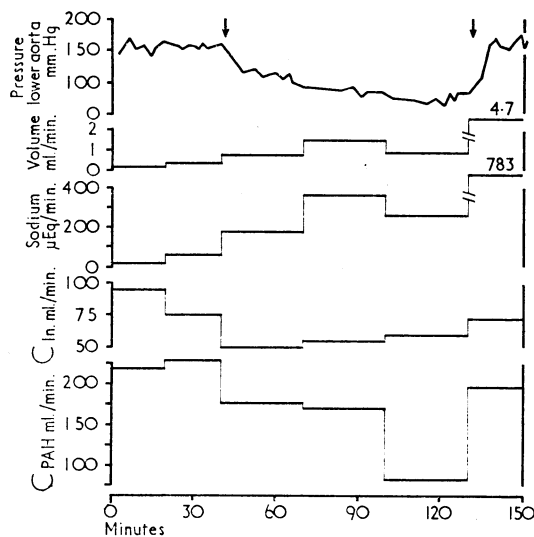

FIG. 12.—Effect on urinary sodium excretion of an intravenous infusion of saline while the renal arterial perfusion pressure, inulin, and para-aminohippuric acid clearance were reduced by partial occlusion of the thoracic aorta with a balloon. The balloon was blown up and the saline administered between the arrows. There is a rise in sodium excretion. (*de Wardener, Mills, Clapham, and Hayter, Clinical Science, 1961, 21, 249.*)

There was nevertheless a brisk rise in sodium excretion, though the amount of sodium filtered at the glomerulus was considerably reduced. It was clear that tubular reabsorption of sodium must have decreased and that this must be due to some mechanism other than a change in the concentration of a circulating salt-retaining steroid. This experiment has been repeated and confirmed by many others.^{39 55 73 95 108} It has since been found that a similar fall in sodium reabsorption also occurs with the acute intravenous administration of plasma or blood.^{4 66 75 105}

Dirks, Cirkseña, and Berliner³⁵ and many others^{21 57 69 97} subsequently have shown with micropuncture techniques that this fall in sodium reabsorption with volume expansion takes place in the proximal tubule. It has also been established that proximal tubule sodium reabsorption also falls in those more prolonged experiments in which the extracellular fluid volume is expanded by the administration of salt-retaining steroids, the fall in proximal sodium reabsorption occurring when the sodium escape phenomenon develops.¹³⁴ In line with these findings it has also been established that acute contraction of the extracellular fluid volume¹¹ or the blood volume⁹¹ causes an increased reabsorption of sodium from the proximal tubule. In contrast, however, distal tubular reabsorption of sodium does not appear to be affected by acute changes in fluid volume.^{69 84 99}

There is now no doubt, therefore, that changes in fluid volumes cause compensatory alterations in sodium reabsorption from the proximal tubule, and that these changes can occur within a few minutes. The mechanisms responsible for these alterations are being investigated with some vigour. Much of the information which has been acquired about the importance of peritubular vascular pressures, and plasma protein osmotic pressures, on sodium reabsorption has been obtained during the course of this search. Nevertheless, as I have already considered these factors in some detail I shall not elaborate further on their undoubted importance during changes in fluid volume. I would like instead to present some of the evidence which

suggests that, in addition, the change in proximal tubule sodium reabsorption which occurs during alterations of fluid volume may be due in part to a hormone.

Effect of Blood Volume Expansion

Our original suggestion that the rise in sodium excretion with volume expansion might be due in part to a change in the circulating concentration of an unknown hormone was originally derived from cross-circulation experiments in two dogs which were receiving large amounts of fludrocortisone.¹²¹ After a control period saline was infused into one of the dogs. It was found that though the fall in packed cell volume, haematocrit value, and plasma protein was the same in the two dogs, and though the blood volume did not change significantly in either dog, nor was there a difference in the changes in blood pressure, venous pressure, glomerular filtration rate, or renal blood flow, yet the rise in sodium excretion in the dog receiving the saline was considerably greater than in the other dog. We concluded that the dilutional changes produced by giving saline caused only a minor rise in sodium excretion, and that the great difference in sodium excretion between the two dogs was due to differences in concentration of some circulating substance other than aldosterone with a short half-life. We thought that a large change in the concentration of this substance occurred in the dog receiving the saline, and that this was due to the substantial expansion of that dog's extracellular fluid. Nevertheless, the short half-life of the substance prevented its concentration changing to the same extent in the other dog.

These experiments have been modified and extended by Johnston and Davis⁵⁹ and Johnston, Davis, Howards, and Wright.⁶⁰ They have obtained similar results and have also come to the conclusion that saline expansion is associated with a change in the concentration of a circulating hormone. On the other hand, McDonald, Schrier, and Lauler,⁷⁹ who also performed similar cross-circulation experiments, concluded that their results did not support the hypothesis that there was a change in the concentration of a circulating hormone.

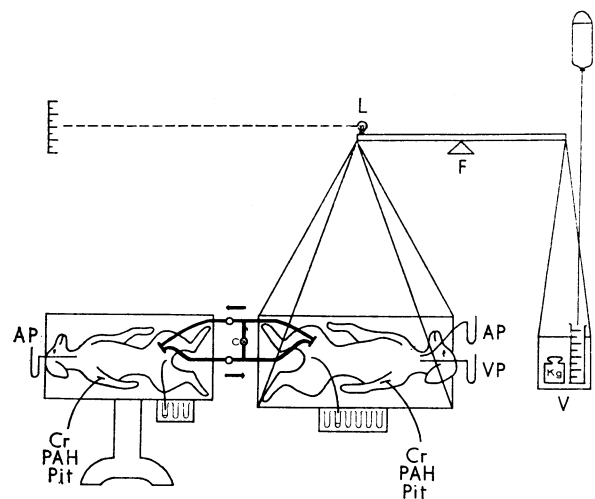

FIG. 13.—Expansion of the blood volume without changing the composition of the blood. The arrangement of the animals during cross-circulation experiments. One dog is on one arm of a beam balance with the fulcrum at F. The counter-weight (kg.) and graduated cylinder (V) are on the other arm. Equilibrium of the balance was continuously measured by the optical lever system on the beam (L). The other dog is on an operating-table. After 45 to 75 minutes of isovolaemic cross-circulation at 200–300 ml./min. in each direction transfusion from the dog on the table to the dog on the balance was carried out by adding water into the graduated cylinder (V) at the required rate. Equilibrium of the balance could then be maintained only by transfusing blood from the dog on the table to the dog on the balance at the same rate as the water was entering the graduated cylinder. (*Bahlmann, McDonald, Ventom, and de Wardener, Clinical Science, 1967, 32, 403.*)

In the course of time it has become clear that in order to obtain more precise evidence for this unknown hormone it is necessary either to use an in-vitro assay, about which I shall say something later, or to use a preparation in which the blood volume is expanded with blood that is already in equilibrium with the blood of the recipient dog. In this way all dilutional problems, which are particularly confusing with saline administration, are avoided.

Bahlmann, McDonald, Ventom, and de Wardener⁴ devised such a technique in which blood was cross-circulated between two dogs, A and B (Fig. 13). At the end of 45 minutes the tubes carrying the blood from dog A to dog B were occluded. In the subsequent five minutes dog B was allowed to expand the blood volume of dog A by about 40%, when all cross-circulation tubes were occluded. In the most relevant experiments the recipient dog (dog A) had previously had one kidney denervated and an aortic snare loosely placed above the origin of both renal arteries. Arrangements were also made to collect the urine from each kidney independently (Fig. 14). On

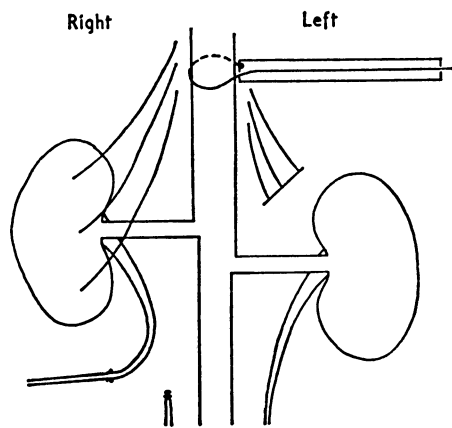

FIG. 14.—Preparation of the recipient dog in the cross-circulation experiments. One week before the experiment one kidney was denervated, an aortic snare was placed above the renal arteries, and arrangements were made to collect urine from each kidney individually. (Bahlmann, McDonald, Ventom, and de Wardener, *Clinical Science*, 1967, 32, 403.)

ISOLATED KIDNEY UNDER ADRENERGIC BLOCKADE

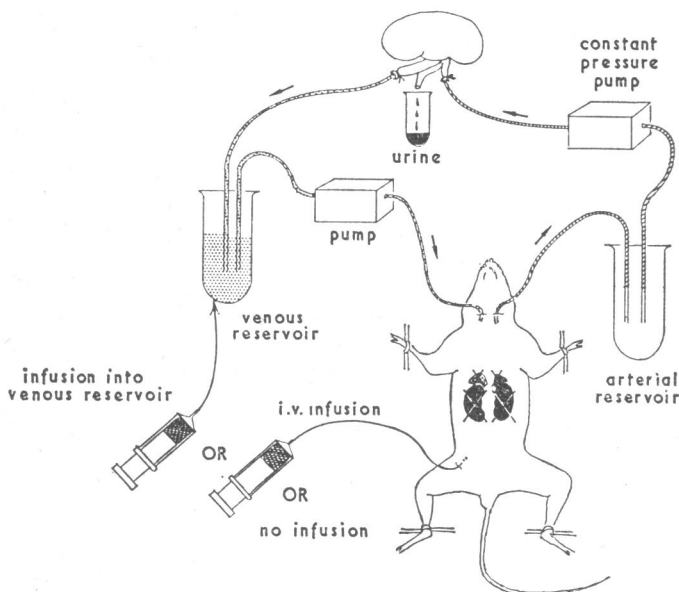

FIG. 15.—Technique to distinguish the effect on urinary sodium excretion of an isolated rat kidney of either diluting the blood or expanding the blood volume of the rat. (Tobian, Coffee, and McCrea, *Transactions of the Association of American Physicians*, 1967, 80, 200.)

expanding the blood volume the aortic snare was tightened to lower the abdominal aortic pressure by a few mm. Hg. There was nevertheless an immediate increase in sodium excretion accompanied by a rise in para-aminohippuric acid (P.A.H.) clearance and filtration rate in both kidneys. We concluded that as the rise in sodium excretion could not be due to a dilutional effect, renal nerve stimulation, or a rise in arterial pressure, it was therefore due to a change in the concentration of some circulating substance which simultaneously increased renal blood flow and glomerular filtration rate.

A similar but more elegant experiment has been performed by Tobian's group.¹¹⁷ An isolated rat kidney was placed between two reservoirs, into one of which there flowed arterial blood from a rat and into the other there flowed venous blood from the kidney. The kidney was supplied with blood from the arterial reservoir at a constant inflow pressure—the renal venous blood was returned to the rat from the renal venous reservoir by another pump (Fig. 15). As in the previous experiment but in an even more demonstrable way the kidney's only connexion with the animal that supplied it with blood was the blood itself. When a quantity of a mixture of two-thirds blood and one-third Ringer's solution was placed into the venous reservoir without expanding the rat's blood volume there was no increase in sodium excretion by the isolated kidney. But when the same amount of blood was infused intravenously into the rat there was usually a large rise in sodium excretion from the isolated kidney (Fig. 16). The rise in sodium excretion

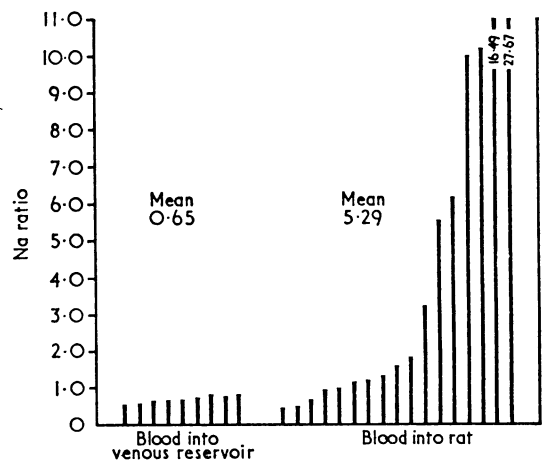

FIG. 16.—Effect on the urinary sodium excretion of an isolated rat kidney of adding two-thirds blood and one-third Ringer's solution either into the venous reservoir or into the rat. Each horizontal bar is one experiment. "Na ratio" = urinary sodium excretion ($\mu\text{Eq}/\text{min.}$) after the blood-Ringer solution had been added, divided by the urinary sodium excretion during the control period. (Tobian, Coffee, and McCrea, *Transactions of the Association of American Physicians*, 1967, 80, 200.)

when the blood was given intravenously was again associated with a rise in renal blood flow and glomerular filtration rate. It was not possible, therefore, to distinguish from this study or from our own whether the increase in sodium excretion caused by the hormone was due to its vasodilatory action on the renal vasculature or to some direct action on cellular sodium transport.

Detection of Unknown Hormone with Frog Skin

In order to try to distinguish between these two possibilities Nutbourne and others⁸⁹ have performed an experiment in which a frog skin has been used to detect the presence of this hormone. Blood from a dog flowed in and out of a membrane cell which contained a frog skin. The dog's blood also flowed in and out of a reservoir which initially contained plasma but which after 30 minutes contained blood now in equilibrium with the blood

of the dog. Four to six hours later, when the frog skin had settled down, the blood volume of the dog was expanded by transfusing some of the blood from the reservoir into the dog. In this way the dog's blood volume was expanded without changing the composition of the blood. On expanding the blood volume the sodium transport across the skin diminished and the urinary sodium excretion rose. The results of this experiment are in line with those of the two preceding experiments. They support the hypothesis that blood volume expansion changes the concentration of a circulating substance which controls urinary sodium excretion, and in addition they suggest that this substance has a direct effect on cellular sodium transport.

In-vitro Assays

Two in-vitro assays have been described.^{14 17} The first was devised by Bricker and his group,¹⁴ who incubated rabbit kidney slices in dog plasma and measured the uptake of para-aminohippuric acid by the slices. They found a protein fraction in plasma obtained from dogs after saline administration, which almost completely inhibits para-aminohippuric acid uptake. The effect of this fraction on sodium and potassium transport could not be measured on kidney slices, but this was the first in-vitro demonstration that the plasma from a volume-expanded animal undergoes a change which influences tubular function.

Clarkson, Talner, and de Wardener¹⁷ devised the second technique in which fragments of tubules were incubated in plasma, taken before and after blood volume expansion. In keeping with the results of Bricker *et al.*¹⁴ they found that the intracellular concentration of para-aminohippuric acid in the tubule fragments was less when such fragments were incubated in plasma taken after expansion; but, in addition, they found that when the tubules were incubated in plasma taken after blood volume expansion the intracellular sodium concentration of the tubule fragments was higher and the potassium concentration lower than in tubule fragments incubated in plasma obtained before blood volume expansion. In other words, tubules incubated in plasma obtained after blood volume expansion were less able to lower the intracellular concentration of sodium than tubules incubated in control plasma. This is an unequivocal demonstration, therefore, that after blood volume expansion the plasma undergoes a change which inhibits net transport of sodium.

Other Assays*

Several other attempts to detect the presence of the hormone in small quantities of plasma have been reported.^{18 19 76 98} In some the published accounts of the methods are obscure. Others have not sustained their early promise.

Site of Production of Unknown Hormone

There has been much speculation about the nature of this hormone, and numerous experiments have been carried out to

* Since this lecture was delivered four further assays were described at the Fourth International Congress of Nephrology in Stockholm in June. Sealey, Kirshman, and Laragh obtained impressive rises in urinary sodium excretion in hydrated rats given extracts of plasma or urine from man or animals maintained on a high salt intake, as opposed to those from normal controls. Potent extracts were also obtained from patients with either primary aldosteronism or essential hypertension. The extracts were prepared from gel filtration and concentrated $\times 1,000$. Viskoper, Czaczkes, Schwartz, and Ullman described similar results in hydrated rats with extracts of urine prepared by dialysis and microfiltration from patients with hypertension. Lichardus, Pliska, Uhrin, and Barth used the sodium transport system of the frog skin, and Buckalew, Martinez, and Green that of the toad bladder, to test dialysates of plasma from sodium-loaded dogs and cows. Both groups obtained significant falls in short-circuit current.

identify its site of production. Many of these have consisted in giving saline to animals from which various organs had been ablated.⁷² As, however, there is no doubt that the administration of saline to animals will produce a fall in plasma protein osmotic pressure and usually a rise in arterial pressure and that both of these will cause a rise in urinary sodium excretion, even in an isolated kidney perfused by a heart-lung preparation^{36 107} or a pump oxygenator,^{23 85 86 87} it is not surprising that the administration of saline to decapitated or eviscerated animals always caused a rise in sodium excretion.⁷²

Ablation of organs is a more suitable way to try to discern the origin of the hormone in animals which are subsequently expanded with whole blood, or preferably blood with which their own blood is clearly in equilibrium. Tobian, Coffee, and McCrea,¹¹⁷ in the experiments which have already been described, removed the adrenals and kidneys from the rat which they used to perfuse the isolated kidney. There was an increase in sodium excretion on expanding the rat with blood. This and other evidence makes it unlikely that the hormone comes from the adrenal or the kidney.⁶⁰

From time to time evidence has been presented that the liver may excrete a hormone which controls sodium excretion.^{81 90 92} Recently this hypothesis has received support from Daly, Roe, and Horrocks.²⁷ They found that there was a greater rise in urinary sodium excretion if 5% saline was injected into the portal vein than when it was injected into the femoral vein (Fig. 17).

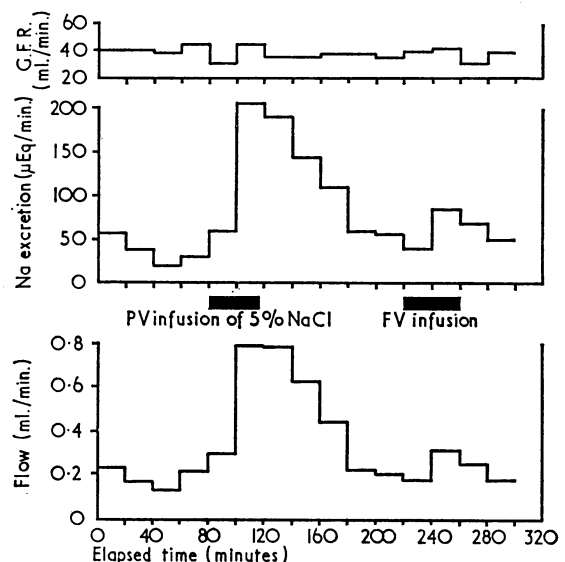

FIG. 17.—Inulin clearance, sodium excretion, and urine flow after portal and femoral vein infusions of 5% saline. (Daly, Roe, and Horrocks, *Clinical Science*, 1967, 33, 481.)

The suggestion that such a hormone might come from the brain was put forward in 1957 by Homer Smith,¹⁰³ who pointed out that the precise control of sodium balance must be very old, probably dating back to the earliest fresh-water vertebrates before the adenohypophysis and adrenal cortical tissue had acquired their present importance in sodium balance, but when the neuraxis was present. Evidence in favour of such a hypothesis has been sporadic and desultory.^{1 20 78} The most startling evidence has come from Lockett,⁷⁸ who perfuses an isolated cat kidney with a heart-lung preparation. The blood used to prime the perfusion circuit is obtained either from a normal cat or from a "headless cat"—that is, an animal that has had the brachiocephalic and left subclavian tied. Lockett found that the addition of 10 ml. of saline to the 120 ml. of blood perfusing the kidney caused an increase in sodium excretion if the blood in the circuit had originally been obtained from a normal cat; whereas if the blood had been obtained from a "headless cat" the addition of 10 ml. of saline did not cause

such a rise. Lockett points out that in these experiments the rise in sodium excretion could not be due to dilution of the circulating blood, and that "it is evident that the hormone responsible for the reduction in renal Na^+ transport in response to salt loading is dependent on the presence of a hormone of intracranial origin either for its release or for its effect."

Andersson, Dallman, and Olsson¹ have used conscious goats in which they have previously placed a fine polyethylene catheter into the third ventricle. Hypertonic saline is infused into the ventricle at the rate of $7.5 \mu\text{l./min.}$ for about one hour. Fig. 18 shows the results from one of the experiments. It can

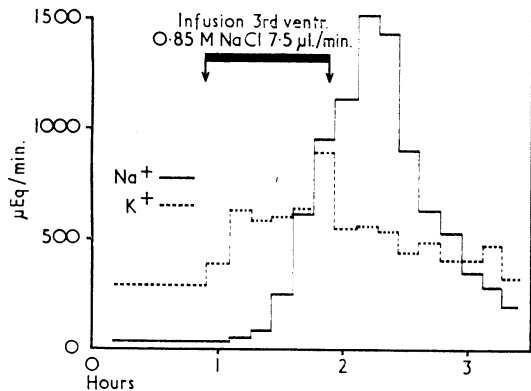

FIG. 18.—Effect on urinary sodium and potassium excretion ($7.5 \mu\text{l./min.}$) 0.85 M NaCl into the third ventricle of a conscious goat. (Andersson, Dallman, and Olsson, *Acta Physiologica Scandinavica*, 1969, 75, 496.)

be seen that urinary sodium excretion rises to more than $1,500 \mu\text{Eq./min.}$ —that is, at a rate roughly equivalent to 1 litre of saline per hour—in spite of the simultaneous administration of large amounts of aldosterone. This is an enormous rise and indicates a gross reduction in sodium reabsorption. Unfortunately the arterial pressure was not measured in these experiments. But the glomerular filtration rate which was measured in three experiments rose by only 20 ml./min. I am aware that the results of this experiment are less than satisfactory evidence that the brain produces a circulating substance which directly influences urinary sodium excretion. Nevertheless, it may be a beginning.

The available evidence suggests that if there is a salt-controlling hormone coming from the brain it is not the anti-diuretic hormone (A.D.H.) or oxytocin. Large amounts of anti-diuretic hormone have been given in nearly all the experiments I have been describing; and, in addition, Schrier, Verroust, Jones, Fabian, Lee, and de Wardener¹⁰⁰ have shown that the circulating concentration of anti-diuretic hormone and oxytocin does not change with saline administration; nor does oxytocin given intravenously have an effect on sodium excretion.

Sodium Reabsorption in Disease

Whether or not one accepts the hormone theory of proximal tubule sodium reabsorption, there is now no doubt that it is the proximal tubule which calls the tune in the control of sodium excretion. It can override anything that the distal tubule does. Once this fact is firmly grasped many clinical situations become a little less difficult to understand.

Diuretics

The interplay between proximal and distal tubule sodium reabsorption is particularly evident when one uses diuretics. It will be recalled that in the old days when an oedematous patient was given a diuretic there was an initial loss of weight, and then the weight levelled out at what was sometimes referred

to as the patient's "dry weight." This was that weight at which no oedema was evident and at which the continued administration of those particular diuretics produced no further loss of weight. This happy self-regulatory state was due to the fact that the effect of these diuretics was principally, if not wholly, on the distal tubule. They caused a diminution in sodium reabsorption by the distal tubule and a gradual reduction in the overexpanded extracellular fluid volume. When this volume had contracted to slightly below normal the reabsorption of sodium from the proximal tubule was stimulated by all those factors about which I have been speaking, and a diminished amount of sodium was then delivered into the distal tubule. The patient came into sodium balance when the enhanced tubular reabsorption of sodium by the proximal tubule was sufficient to prevent the poisoned distal tubule from releasing more than that quantity of sodium necessary to keep the extracellular fluid volume constant. At this point the patient could be said to be diuretic-resistant.

On the other hand, it is more customary to use the term "diuretic resistance" only when a diuretic fails to have an effect at a time when the patient is still oedematous. This natural state of diuretic resistance occurs when the disease causes such an intense reabsorption of sodium in the proximal tubule that little, if any, sodium finds its way into the distal tubule, and therefore the diuretic has, so to speak, nothing to work on.

Frusemide, however, acts on both the distal and the proximal tubule,¹² and it therefore impairs the proximal tubule's normal capacity to adjust to a contraction of the extracellular fluid volume. With this drug, therefore, urinary sodium excretion may continue uninterrupted even though the patient develops severe sodium deficiency.

Diabetes Insipidus

The successful use of diuretics in the treatment of diabetes insipidus is again based on this juxtaposition of proximal and distal tubular reabsorption of sodium. In diabetes insipidus the absence of anti-diuretic hormone results in little or no water being reabsorbed from the distal tubule or the collecting duct; therefore the rate at which fluid is delivered into the distal tubule will determine the rate of urine flow. But the rate at which fluid is delivered into the distal tubule is dependent on the amount of sodium that is reabsorbed in the proximal tubule. If a diuretic is given to a patient with diabetes insipidus the loss of sodium causes an initial contraction of the extracellular fluid volume. This, in turn, causes an increased reabsorption of sodium and water from the proximal tubule so that less water is delivered into the distal tubule and therefore there is a diminution in urine flow.

These are examples in which the proximal tubule increases its reabsorption in order to prevent the extracellular fluid volume becoming depleted in spite of a diminished reabsorption of sodium and water by the distal tubule.

Primary Aldosteronism and Hyperadrenalism

The reverse situation obtains in primary aldosteronism or hyperadrenalism when sodium reabsorption in the distal tubule is increased—and yet generalized oedema does not occur. This is due to the sodium escape phenomenon, about which I have already spoken. Aldosterone's effect on distal tubule sodium reabsorption increases the extracellular fluid volume, and this in turn causes an inhibition of sodium reabsorption in the proximal tubule. The avid reabsorption in the distal tubule, however, continues so that even more sodium is reabsorbed. But in the distal tubule sodium is reabsorbed in part-exchange for potassium, so that the proximal tubule's

attempt to compensate for the distal tubule's increased sodium reabsorption inadvertently causes an increased urinary excretion of potassium. Eventually sodium balance is achieved when the proximal tubule releases sufficient sodium to swamp the distal tubule's sodium-retaining effect, but at the cost of a large urinary leak of potassium. This is therefore an example of the proximal tubule reabsorbing less sodium in order to counteract the distal tubule's increased reabsorption.

Renal Artery Stenosis

In renal artery stenosis the diminished vascular hydrostatic pressure in the peritubular capillaries of the kidney with the stenosed renal artery causes that kidney to have a greatly increased reabsorption of sodium and water. Consequently those constituents of the tubule fluid which are not reabsorbed, such as creatinine or Hypaque (sodium diatrizoate) are much more concentrated than usual. This is the cause, therefore, of the typical findings in the urine from a kidney with renal artery stenosis. The urine has a low concentration of sodium but a high concentration of creatinine and sodium diatrizoate and the rate of urine flow is slow. The high concentration of sodium diatrizoate, of course, makes itself evident by the increased density of the affected kidney in an intravenous pyelogram. In addition, the increased reabsorption of sodium in the kidney with the stenosed artery causes an increase in the extracellular fluid volume. This causes a compensatory decrease in sodium reabsorption in the proximal tubules of the other, unaffected kidney, so that more is delivered into the distal tubule. But the fall in the intrarenal vascular pressure in the kidney with the stenosed renal artery causes a release of renin from the juxtaglomerular apparatus, the formation of angiotensin, and a rise in the circulating concentration of aldosterone.

The aldosterone then acts on the distal tubules of both kidneys. In the affected kidney very little sodium reaches the distal tubule, but in the unaffected kidney there is a flood of sodium coming into the distal tubule from the inhibited proximal tubule. As this large amount of sodium travels through the distal tubule it is under the influence of the high concentration of circulating aldosterone. Much of the sodium is reabsorbed in exchange for potassium, and thus the urinary excretion of potassium from the unaffected kidney rises precipitously. In spite of these multiple mechanisms for sodium retention—that is, increased sodium reabsorption in the proximal and distal tubule of the kidney with the stenosed renal artery and in the distal tubule of the unaffected kidney—the proximal tubule of the unaffected kidney can compensate sufficiently to prevent the formation of oedema.

Chronic Renal Failure

In chronic renal failure the intake of sodium is usually normal and the patient is rarely oedematous. Therefore, as the number of nephrons diminishes sodium excretion per nephron must increase. In other words, as renal failure advances sodium reabsorption per nephron diminishes.¹³ The mechanism responsible for this nice adjustment is unknown. It certainly is not due to a diminished aldosterone effect on the distal tubule, for, on the contrary, the evidence is that in chronic renal failure the circulating concentration of aldosterone is raised.

Generalized Oedema

I have left a consideration of generalized oedema until last, for it is the least satisfactory to discuss. By generalized oedema I mean an increase in sodium and water reabsorption sufficient to cause a clinically obvious increase in the extracellular fluid volume. It is clear from what I have said that such an increase cannot be due to aldosterone alone. In other words, distal

tubular sodium reabsorption cannot cause generalized oedema unless the compensatory sodium escape phenomenon of the proximal tubule does not interfere. Alternatively, of course, generalized oedema could occur by an increased reabsorption of sodium from the proximal tubule whatever the level of aldosterone. Therefore until we know more precisely what controls sodium reabsorption from the proximal tubule the cause of generalized oedema will remain obscure. At least we now have some idea where to pursue our inquiries.

When general oedema occurs in conditions in which there is a tendency for the blood volume to be low this will cause an increased sodium reabsorption in the proximal tubule by some of the mechanisms I have been discussing, and from the distal tubule by an increased circulatory concentration of aldosterone. This, presumably, is the state of affairs in the generalized oedema associated with the nephrotic syndrome, malnutrition, and protein-losing enteropathy. The same mechanisms may also work in liver failure and cirrhosis of the liver, but the position is not so clear-cut, for the blood volume is often normal. In cardiac failure the blood volume is usually normal and aldosterone excretion is variable. In cardiac failure, therefore, sodium and water retention may be due solely to increased sodium reabsorption in the proximal tubule. Barger and his colleagues^{7, 6} have suggested that this is due to a redistribution of renal blood flow for they have found that in cardiac failure the blood tends to be diverted from the superficial cortical nephrons to the deep cortical nephrons. They have put forward various hypotheses why such a redistribution might cause a diminution in sodium excretion, including the proposal that sodium reabsorption in the renal cortex might be increased because of a fall in the peritubular venous capillaries.^{9,3}

Conclusion

In summary, therefore, urinary sodium excretion is controlled by adjustments in sodium reabsorption by the tubules, and appears to be little influenced by changes in glomerular filtration rate. Most of the filtered sodium is reabsorbed in the proximal tubule, where the rate of reabsorption is closely related to the hydrostatic and plasma protein osmotic pressures in the peritubular venous capillaries. It has also been established that sodium reabsorption in the proximal tubule is inversely related to changes in the volume of the extracellular fluid volume. There is considerable evidence, however, against the hypothesis that such compensatory changes are due only to changes in peritubular hydrostatic or plasma protein osmotic pressure. Many experiments suggest that the changes in sodium reabsorption which occur in response to changes in the volume of the extracellular fluid volume are also due in part to a change in the circulating concentration of an unknown hormone other than aldosterone, angiotensin, oxytocin, or antidiuretic hormone. The overriding importance on urinary sodium excretion of those factors which control sodium reabsorption in the proximal tubule helps to explain the anomaly that generalized oedema does not occur in hyperaldosteronism.

It is a pleasure to acknowledge my indebtedness to all those with whom I have worked on some of these problems, including I. H. Mills, C. J. Hayter, W. F. Clapham, S. J. McDonald, J. Bahlmann, M. G. Ventom, R. W. Schrier, P. Verroust, J. Lee, L. B. Talner, D. M. Nutbourne, and E. M. Clarkson. I would also like to thank the following sources of financial support, without which the work could not have been carried out: National Institutes of Health, Department of Health, Education and Welfare, Public Health Service of the U.S.A. Grant No. AM-05008; Wellcome Trust; Medical Research Council; Charing Cross Hospital Subcommittee for Clinical Research; Ockley Brick Works; Cerebos Ltd.; Dan Mason Research Fund; the Rotary Club of London; and the Kemp Benevolent Fund.

The illustrations are reproduced by kind permission of those concerned.

REFERENCES

- ¹ Andersson, B., Dallman, M. F. and Olsson, K., *Acta Physiologica Scandinavica*, 1969, **75**, 496.
- ² August, J. T., Nelson, D. H., and Thorn, G. W., *Journal of Clinical Investigation*, 1958, **37**, 1549.
- ³ Bachman, D. M., and Youmans, W. B., *Circulation*, 1953, **7**, 413.
- ⁴ Bahlmann, J., McDonald, S. J., Ventom, M. G., and de Wardener, H. E., *Clinical Science*, 1967, **32**, 403.
- ⁵ Barger, A. C., *Annals of the New York Academy of Sciences*, 1966, **139**, 276.
- ⁶ Barger, A. C., Herd, J. A., and Sparks, H. V. (editors), *Symposium on Congestive Heart Failure*, 1966, p. 49. New York, American Heart Association.
- ⁷ Blake, W. D., Wégria, R., Keating, R. P., and Ward, H. P., *American Journal of Physiology*, 1949, **157**, 1.
- ⁸ Blake, W. D., Wégria, R., Ward, H. P., and Frank, C. W., *American Journal of Physiology*, 1950, **163**, 422.
- ⁹ Bojesen, E., *Acta Physiologica Scandinavica*, 1954, **32**, 129.
- ¹⁰ Brenner, B. M., Bennett, C. M., and Berliner, R. W., *Journal of Clinical Investigation*, 1968, **47**, 1358.
- ¹¹ Brenner, B. M., and Berliner, R. W., *The relationship between E.C.F. Volume and Na Reabsorption by the Rat Nephron*, Abstract American Society of Nephrology, 1968, Washington.
- ¹² Brenner, B. M., Keimowitz, R. I., Wright, F. S., and Berliner, R. W., *Journal of Clinical Investigation*, 1969, **48**, 290.
- ¹³ Bricker, N. S., *American Journal of Medicine*, 1967, **43**, 313.
- ¹⁴ Bricker, N. S., Klahr, S., Purkerson, M., Schultze, R. G., Avioli, L. V., and Birge, S. J., *Nature*, 1968, **219**, 1058.
- ¹⁵ Burg, M. B., and Orloff, J., *Journal of Clinical Investigation*, 1968, **47**, 2016.
- ¹⁶ Clapp, J. R., Rector, F. C., and Seldin, D. W., *American Journal of Physiology*, 1962, **202**, 781.
- ¹⁷ Clarkson, E. M., Talner, L. B., and de Wardener, H. E., The effect of plasma from blood volume expanded dogs on sodium and potassium transport of suspended fragments of dog kidney tubules. IV International Congress of Nephrology, 1969, in preparation.
- ¹⁸ Cort, J. H., *Electrolytes, Fluid Dynamics and the Nervous System*, 1965. New York, Academic Press.
- ¹⁹ Cort, J. H., Douša, T., Pliška, V., Lichardus, B., Safářová, J., Vranešić, M., and Rudinger, J., *American Journal of Physiology*, 1968, **215**, 921.
- ²⁰ Cort, J. H., and Lichardus, B., *Physiologia Bohemoslovenica*, 1963, **12**, 291.
- ²¹ Cortney, M. A., Mylle, M., Lassiter, W. E., and Gottschalk, C. W., *American Journal of Physiology*, 1965, **209**, 1199.
- ²² Cortney, M. A., Nagel, W., and Thurau, K., *Pflügers Archiv für die gesamte Physiologie des Menschen und der Tiere*, 1966, **287**, 286.
- ²³ Craig, G. M., Mills, I. H., Osbaldiston, G. W., and Wise, B. L., *Journal of Physiology*, 1966, **186**, 113P.
- ²⁴ Crawford, B., and Ludemann, H., *Journal of Clinical Investigation*, 1951, **30**, 1456.
- ²⁵ Curran, P. F., and Macintosh, J. R., *Nature*, 1962, **193**, 347.
- ²⁶ Cushny, A. R., *The Secretion of Urine*, 1917. London, Longmans Green.
- ²⁷ Daly, J. J., Roe, J. W., and Horrocks, P., *Clinical Science*, 1967, **33**, 481.
- ²⁸ Daugharty, T. M., Belleau, L. J., Martino, J. A., and Earley, L. E., *American Journal of Physiology*, 1968, **215**, 1442.
- ²⁹ Davies, D. F., and Shock, N. W., *Journal of Clinical Investigation*, 1950, **29**, 491.
- ³⁰ Dean, R. F. A., and McCance, R. A., *Journal of Physiology*, 1949, **109**, 81.
- ³¹ Deetjen, P., and Kramer, K., *Klinische Wochenschrift*, 1960, **38**, 680.
- ³² Diamond, J. M., *Journal of General Physiology*, 1964, **48**, 15.
- ³³ Diamond, J. M., and Bossert, W. H., *Journal of General Physiology*, 1967, **50**, 2061.
- ³⁴ Diamond, J. M., and Tormey, J. McD., *Federation Proceedings*, 1966, **25**, 1458.
- ³⁵ Dirks, J. H., Cirkseña, W. J., and Berliner, R. W., *Journal of Clinical Investigation*, 1965, **44**, 1160.
- ³⁶ Dreyer, N. B., and Verney, E. B., *Journal of Physiology*, 1923, **57**, 451.
- ³⁷ Earley, L. E., *Annals of the New York Academy of Sciences*, 1966, **139**, 312.
- ³⁸ Earley, L. E., and Daugharty, J. M., *New England Journal of Medicine*, 1969. In press.
- ³⁹ Earley, L. E., and Friedler, R. M., *Journal of Clinical Investigation*, 1964, **43**, 1928.
- ⁴⁰ Earley, L. E., and Friedler, R. M., *Journal of Clinical Investigation*, 1965, **44**, 929.
- ⁴¹ Earley, L. E., and Friedler, R. M., *Journal of Clinical Investigation*, 1965, **44**, 1857.
- ⁴² Earley, L. E., and Friedler, R. M., *Journal of Clinical Investigation*, 1966, **45**, 542.
- ⁴³ Earley, L. E., Martino, J. A., and Friedler, R. M., *Journal of Clinical Investigation*, 1966, **45**, 1668.
- ⁴⁴ Eigler, F. W., *American Journal of Physiology*, 1961, **201**, 157.
- ⁴⁵ Farquhar, M. G., and Palade, G. E., *Journal of Cell Biology*, 1963, **17**, 375.
- ⁴⁶ Farquhar, M. G., and Palade, G. E., *Proceedings of the National Academy of Sciences of the United States of America*, 1964, **51**, 569.
- ⁴⁷ Farquhar, M. G., and Palade, G. E., *Journal of Cell Biology*, 1966, **30**, 359.
- ⁴⁸ Fujimoto, M., Nash, F. D., and Kessler, R. H., *Federation Proceedings*, 1963, **22**, 631.
- ⁴⁹ Ganote, C. E., Grantham, J. J., Moses, H. L., Burg, M. B., and Orloff, J., *Journal of Cell Biology*, 1968, **36**, 355.
- ⁵⁰ Gertz, K. H., *Pflügers Archiv für die gesamte Physiologie des Menschen und der Tiere*, 1963, **276**, 336.
- ⁵¹ Giebisch, G., *Journal of Cellular and Comparative Physiology*, 1958, **51**, 221.
- ⁵² Giebisch, G., *Circulation*, 1960, **21**, 879.
- ⁵³ Giebisch, G., *Journal of General Physiology*, 1961, **44**, 659.
- ⁵⁴ Giebisch, G., Klose, R. M., Malnic, G., Sullivan, W. J., and Windhager, E. E., *Journal of General Physiology*, 1964, **47**, 1175.
- ⁵⁵ Goldberg, M., Staum, B. B., and Cristol, J. L., *Journal of Clinical Investigation*, 1968, **47**, 41a.
- ⁵⁶ Gottschalk, C. W., and Mylle, M., *American Journal of Physiology*, 1959, **196**, 927.
- ⁵⁷ Hayslett, J. P., Kashgarian, M., and Epstein, F. H., *Journal of Clinical Investigation*, 1967, **46**, 1254.
- ⁵⁸ Horster, M., and Thurau, K., *Pflügers Archiv für die gesamte Physiologie des Menschen und der Tiere*, 1968, **301**, 162.
- ⁵⁹ Johnston, C. I., and Davis, J. O., *Proceedings of the Society for Experimental Biology and Medicine*, 1966, **121**, 1058.
- ⁶⁰ Johnston, C. I., Davis, J. O., Howards, S. S., and Wright, F. S., *Circulation Research*, 1967, **20**, 1.
- ⁶¹ Kaplan, S. A., and Rapoport, S., *American Journal of Physiology*, **164**, 175.
- ⁶² Kashgarian, M., Stöckle, H., Gottschalk, C. W., and Ullrich, K. J., *Pflügers Archiv für die gesamte Physiologie des Menschen und der Tiere*, 1963, **277**, 89.
- ⁶³ Kashgarian, M., Warren, Y., Mitchell, R. L., and Epstein, F. H., *Proceedings of the Society for Experimental Biology and Medicine*, 1964, **117**, 848.
- ⁶⁴ Katz, A. I., and Epstein, F. H., *Journal of Clinical Investigation*, 1967, **46**, 1999.
- ⁶⁵ Kiil, F., Aukland, K., and Refsum, H. E., *American Journal of Physiology*, 1961, **201**, 511.
- ⁶⁶ Knox, F. G., Howards, S. S., Wright, F. S., Davis, B. B., and Berliner, R. W., *American Journal of Physiology*, 1968, **215**, 1041.
- ⁶⁷ Koch, K. M., Aynedjian, H. S., and Bank, N., *Journal of Clinical Investigation*, 1968, **47**, 1696.
- ⁶⁸ Kramer, K., and Deetjen, P., *Pflügers Archiv für die gesamte Physiologie des Menschen und der Tiere*, 1960, **271**, 782.
- ⁶⁹ Landwehr, D. M., Klose, R. M., and Giebisch, G., *American Journal of Physiology*, 1967, **212**, 1327.
- ⁷⁰ Lassen, N. A., Munck, O., and Thaysen, J. H., *Acta Physiologica Scandinavica*, 1961, **51**, 371.
- ⁷¹ Latham, W., *Journal of Clinical Investigation*, 1956, **35**, 947.
- ⁷² Levinsky, N. G., *Annals of the New York Academy of Sciences*, 1966, **139**, 295.
- ⁷³ Levinsky, N. G., and Lalone, R. C., *Journal of Clinical Investigation*, 1963, **42**, 1261.
- ⁷⁴ Lewy, J. E., and Windhager, E. E., *American Journal of Physiology*, 1968, **214**, 943.
- ⁷⁵ Lichardus, B., and Pearce, J. W., *Federation Proceedings (Abstracts)*, 1965, **24**, 404.
- ⁷⁶ Lichardus, B., Pliška, V., Uhrin, V., and Barth, T., *Lancet*, 1968, **1**, 127.
- ⁷⁷ Lindheimer, M. D., Lalone, R. C., and Levinsky, N. G., *Journal of Clinical Investigation*, 1967, **46**, 256.
- ⁷⁸ Lockett, M. F., *Journal of Physiology*, 1966, **187**, 489.
- ⁷⁹ McDonald, M., Schrier, R. W., and Lauer, D. P., *Nephron*, 1967, **4**, 1.
- ⁸⁰ Martino, J. A., and Earley, L. E., *Journal of Clinical Investigation*, 1967, **46**, 1963.
- ⁸¹ Milies, E., *Acta Physiologica Latino Americana*, 1960, **10**, 178.
- ⁸² Morgan, T., and Berliner, R. W., Abstract American Society of Nephrology, 1968 Annual Meeting, Washington.
- ⁸³ Morgan, T., and Berliner, R. W., *American Journal of Physiology*. In press.
- ⁸⁴ Morgan, T., and Berliner, R. W., *Nephron*. In press.
- ⁸⁵ Nizet, A., *Pflügers Archiv für die gesamte Physiologie des Menschen und der Tiere*, 1967, **297**, 156.
- ⁸⁶ Nizet, A., Cuypers, Y., Deetjen, P., and Kramer, K., *Pflügers Archiv für die gesamte Physiologie des Menschen und der Tiere*, 1967, **296**, 179.
- ⁸⁷ Nizet, A., Godon, J. P., and Mahieu, P., *Pflügers Archiv-European Journal of Physiology*, 1968, **304**, 30.
- ⁸⁸ Nutbourne, D. M., *Journal of Physiology*, 1968, **195**, 1.
- ^{89a} Nutbourne, D. M., and Howse, J. D., The effect of hydrostatic pressure gradients of less than 2 mm. water on active sodium transport across isolated frog skins. In preparation.
- ^{89b} Nutbourne, D. M., Howse, J. D., Schrier, R. W., Talner, L. B., Ventom, M. G., Verroust, P. J., and de Wardener, H. E., The effect of expanding the blood volume of a dog on the sodium transport of an isolated frog skin incorporated in the dog's circulation. In preparation.
- ⁹⁰ Oettel, H., *Zeitschrift für die gesamte experimentelle Medizin*, 1943, **111**, 613.
- ⁹¹ Pena, J. C., Lennhoff, M., and Vasquez, A., Sodium retaining factors independent of aldosterone. Abstract, American Society of Nephrology, 1968.
- ⁹² Pick, E. P., *Journal of Mount Sinai Hospital*, 1946, **13**, 167.
- ⁹³ Pomeranz, B. H., Birtch, A. G., and Barger, A. C., *American Journal of Physiology*, 1968, **215**, 1067.
- ⁹⁴ Rector, F. C., Brunner, F. P., and Seldin, D. W., *Journal of Clinical Investigation*, 1966, **45**, 590.
- ⁹⁵ Rector, F. C., Giesen, G. V., Kiil, F., and Seldin, D. W., *Journal of Clinical Investigation*, 1964, **43**, 341.
- ⁹⁶ Rector, F. C., Martínez-Maldonado, M., Kurtzman, N. A., Sellman, J. C., Oerther, F., and Seldin, D. W., *Journal of Clinical Investigation*, 1968, **47**, 761.
- ⁹⁷ Rector, F. C., Sellman, J. C., Martínez-Maldonado, M., and Seldin, D. W., *Journal of Clinical Investigation*, 1967, **46**, 47.
- ⁹⁸ Relman, A. S., and Schwartz, W. B., *Yale Journal of Biological Medicine*, 1952, **24**, 540.
- ⁹⁹ Schnermann, J., *Pflügers Archiv für die gesamte Physiologie des Menschen und der Tiere*, 1968, **300**, 255.

- ¹⁰⁰ Schrier, R. W., Verroust, P. J., Jones, J. J., Fabian, M., Lee, J., and de Wardener, H. E., *Clinical Science*, 1968, **35**, 433.
- ¹⁰¹ Selkurt, E. E., and Post, R. S., *American Journal of Physiology*, 1950, **162**, 639.
- ¹⁰² Slatopolsky, E., Elkan, I. O., Weerts, C., and Bricker, N. S., *Journal of Clinical Investigation*, 1968, **47**, 521.
- ¹⁰³ Smith, H. W., *American Journal of Medicine*, 1957, **23**, 623.
- ¹⁰⁴ Solomon, S., *Journal of Cellular and Comparative Physiology*, 1957, **49**, 351.
- ¹⁰⁵ Sonnenberg, H., and Pearce, J. W., *American Journal of Physiology*, 1962, **203**, 344.
- ¹⁰⁶ Stamler, J., Dreifus, L., Katz, L. N., and Lichton, I. J., *American Journal of Physiology*, 1958, **195**, 362.
- ¹⁰⁷ Starling, E. H., and Verney, E. B., *Proceedings of the Royal Society. Series B. Biological Sciences*, 1925, **97**, 321.
- ¹⁰⁸ Stein, R. M., Bercovitch, D. D., and Levitt M. F., *American Journal of Physiology*, 1964, **207**, 826.
- ¹⁰⁹ Steinhausen, M., *Pflügers Archiv für die gesamte Physiologie des Menschen und der Tiere*, 1963, **277**, 23.
- ¹¹⁰ Steinhausen, M., *Pflügers Archiv für die gesamte Physiologie des Menschen und der Tiere*, 1964, **279**, 195.
- ¹¹¹ Strauss, M. B., Davis, R. K., Rosenbaum, J. D., and Rossmeisl, E. C., *Journal of Clinical Investigation*, 1952, **31**, 80.
- ¹¹² Strauss, M. B., and Earley, L. E., *Transactions of the Association of American Physicians*, 1959, **72**, 200.
- ¹¹³ Thaysen, J. H., Lassen, N. A., and Munck, O., *Nature*, 1961, **190**, 919.
- ¹¹⁴ Thurau, K., *Proceedings of the Society for Experimental Biology and Medicine*, 1961, **106**, 714.
- ¹¹⁵ Tisher, C. C., Bulger, R. E., and Trump, B. F., *Laboratory Investigation*, 1966, **15**, 1357.
- ¹¹⁶ Tisher, C. C., and Cirksena, W. J., Sodium localisation by electron microscopy (E.M.) in single perfused renal tubules. Abstract, American Society of Nephrology 1968, Washington.
- ¹¹⁷ Tobian, L., Coffee, K., and McCrea, P., *Transactions of the Association of American Physicians*, 1967, **80**, 200.
- ¹¹⁸ Ullrich, K. J., Rumrich, G., and Fuchs, G., *Pflügers Archiv für die gesamte Physiologie des Menschen und der Tiere*, 1964, **280**, 99.
- ¹¹⁹ Voute, C. L., *Journal of Ultrastructure Research*, 1963, **9**, 497.
- ¹²⁰ Walker, A. M., Bott, P. A., Oliver, J., and MacDowell, M. C., *American Journal of Physiology*, 1941, **134**, 580.
- ¹²¹ Wardener, de H. E., Mills, I. H., Clapham, W. F., and Hayter, C. J., *Clinical Science*, 1961, **21**, 249.
- ¹²² Welt, L. G., in *Diseases of Metabolism*, 5th ed., edited by G. G. Duncan, 1964, p. 486. Philadelphia, Saunders.
- ¹²³ Wesson, L. G., *Medicine*, 1957, **36**, 281.
- ¹²⁵ Whittembury, G., Sugino, N., and Solomon, A. K., *Journal of General Physiology*, 1961, **44**, 689.
- ¹²⁶ Whittembury, G., and Windhager, E. E., *Journal of General Physiology*, 1961, **44**, 679.
- ¹²⁷ Wiederholt, M., Hierholzer, K., Windhager, E. E., and Giebisch, G., *American Journal of Physiology*, 1967, **213**, 809.
- ¹²⁸ Wiggins, W. S., Manry, C. H., Lyons, R. H., and Pitts, R. F., *Circulation*, 1951, **3**, 275.
- ¹²⁹ Windhager, E. E., *American Journal of Physiology*, 1964, **206**, 694.
- ¹³⁰ Windhager, E. E., and Giebisch, G., *American Journal of Physiology*, 1961, **200**, 581.
- ¹³¹ Windhager, E. E., Lewy, J. E., and Spitzer, A., *Nephron*, 1969, **6**, 247.
- ¹³² Wirz, H., *Helvetica Physiologica et Pharmacologica Acta*, 1956, **14**, 353.
- ¹³³ Wright, F. S., Brenner, B. M., Bennett, C. M., Keimowitz, R. I., Berliner, R. W., Schrier, R. W., Verroust, P. J., de Wardener, H. E., and Holzgreve, H., *Journal of Clinical Investigation*, 1969, **48**, 1107.
- ¹³⁴ Wright, F. S., Knox, F. H., Howards, S. S., and Berliner, R. W., *American Journal of Physiology*, 1969, **216**, 869.

Triple Starr Valve Replacement

M. V. BRAIMBRIDGE,* M.A., M.B., F.R.C.S.; A. J. CLEMENT,† M.B., D.A., F.F.A.R.C.S.
A. HEDLEY BROWN,‡ M.B., B.S., F.R.C.S.; E. SABAR,§ M.D.; D. MENDEL,|| M.B., B.S., M.R.C.P.

[WITH SPECIAL PLATE BETWEEN PAGES 692-693]

British Medical Journal, 1969, **3**, 683-688

Summary: Of nine patients who have had triple valve replacements for organic rheumatic triple valve disease two died in the postoperative period from inadequate myocardial reserve, and a third died four months later from cerebral embolism originating from clot on the left atrial wall. The remainder are well and, except for one, leading normal lives. Though cardiac transplantation has been recommended and used successfully for triple valve disease by Cooley, it is suggested that the long-term outlook today of triple valve replacement is likely to be better than that of transplantation.

Introduction

Cooley *et al.* (1968) suggested that severe multiple valve disease due to rheumatic fever could be treated by transplantation of the heart and had performed one such operation. The risks and benefits of triple valve replacement, which is the alternative, have therefore to be compared with those of transplantation.

A single heart valve can be replaced today with an operative mortality of some 10-15%, with deaths due mainly to pulmonary vascular or myocardial disease. The safety of triple valve replacement has not yet reached this stage. Experience

is relatively small and the operative technique, postoperative management, and long-term results are still not uniform. The purpose of this paper is to report a personal series of nine triple valve replacements performed at St. Thomas's Hospital between July 1966 and May 1968, with an assessment of the risks involved and the functional results obtained.

Pathology.—Triple valve disease is always due to rheumatic fever (Special Plate, Fig. 1). Regurgitation was the dominant lesion in each valve of every patient in this series, though a significant degree of stenosis accompanied regurgitation in four mitral, two aortic, and five tricuspid valves. Four of the mitral and two of the aortic valves were calcified.

Indications for Triple Valve Replacement

Our minimum indication for operation is moderately severe dyspnoea with inability to walk at a good pace on the flat (grade 2b on the Wood grading). Dyspnoea on exertion was severe in seven patients, gross in one, and moderately severe in one in this series (see Table). Dyspnoea was accompanied by orthopnoea in seven and by paroxysmal nocturnal dyspnoea in five patients. Angina pectoris was present in two patients, with effort syncope in one patient.

Each patient received intensive preliminary medical treatment before the final clinical examination and cardiac catheterization, and this was continued until no further improvement could be obtained. The jugular venous pressure, which was raised on admission in all patients, was reduced to normal by

* Consultant Surgeon.

† Consultant Anaesthetist.

‡ Lecturer in Cardiac Surgery, Cardiothoracic Unit.

§ Consultant Physician, Cardiothoracic Unit.

St. Thomas's Hospital, London S.E.1.

|| Professor of Cardiothoracic Surgery, University of Erzurum, Turkey.