

## Insertion and Amplification of Foreign Genes in the *Lactococcus lactis* subsp. *lactis* Chromosome

MARIE-CHRISTINE CHOPIN,<sup>1\*</sup> ALAIN CHOPIN,<sup>1</sup> ANNETTE ROUAULT,<sup>2</sup> AND NATHALIE GALLERON<sup>1</sup>  
*Laboratoire de Génétique Microbienne, Institut de Biotechnologie, INRA-Domaine de Vilvert, 78350 Jouy-en-Josas,<sup>1</sup>  
and Laboratoire de Recherche de Technologie Laitière, INRA, 35042 Rennes Cedex,<sup>2</sup> France*

Received 12 December 1988/Accepted 4 April 1989

**The plasmid pE194 is unable to replicate in *Lactococcus lactis* subsp. *lactis* (formerly *Streptococcus lactis*). When linked to resident bacteriophage sequences, pE194 was able to integrate into the *L. lactis* subsp. *lactis* chromosome either by Campbell-like recombination or by double crossing over with deletion. Integration occurred into the DNA of the prophage and prevented its multiplication. When a selective pressure was applied to an integrant in which pE194 was flanked by two direct repeats of prophage fragment, amplification of pE194 and the prophage fragment was observed. The pE194 copy number was assessed at six to nine, and amplification was stable upon growth under nonselective conditions.**

Chromosomal integration of foreign DNA sequences linked to chromosomal sequences by homologous recombination has been described for *Bacillus subtilis* (4, 7, 19), *Streptococcus pneumoniae* (16, 31), *Escherichia coli* (7, 22), and other bacterial species (1, 7). This phenomenon has been used in a variety of genetic manipulations, including insertion mutagenesis (16, 18, 19, 32), subsequent mapping or cloning of the inactivated genes or neighboring regions (3, 8, 16, 31, 33), introduction of defined deletions (7, 20), replacement of bacterial genes (7, 28), and stable maintenance of a single copy of a gene whose product can be toxic to the host cell (22). Chromosomal integration can result in two direct repeats of the homologous DNA flanking the foreign integrated DNA (19), a structure which is susceptible to amplification in *E. coli* (7), *S. pneumoniae* (30), *Streptomyces fradiae* (5), *B. subtilis* (9, 12, 34, 35), and other species (7).

Because chromosomal integration offers so many possibilities for genetic manipulations and analysis, we used it in *Lactococcus lactis* subsp. *lactis* (formerly *Streptococcus lactis*), for which an efficient transformation procedure is available (27). In this report, we present our results on the integration and amplification of pE194 carrying a prophage DNA insert in the *L. lactis* subsp. *lactis* chromosome by homologous recombination with resident prophage sequences.

### MATERIALS AND METHODS

**Bacterial strains.** Bacterial strains are listed in Table 1. The plasmid pE194 was a naturally occurring isolate from *Staphylococcus aureus* (11). *L. lactis* subsp. *lactis* strains were grown in M17 medium (29) in which lactose was replaced by glucose (M17glc).

**Prophage induction.** An early exponential-phase culture (1 liter; approximately  $10^8$  CFU/ml) was centrifuged and suspended in the same volume of saline solution. The cell suspension was then irradiated in a 2-liter beaker under constant stirring with a 254-nm UV lamp at a UV fluence of 180 J/m<sup>2</sup> measured with a Black-ray UVX radiometer (Ultraviolet Products, Inc., San Gabriel, Calif.). The irradiated culture was pelleted and suspended in the same volume of fresh M17glc broth. After clearing during subsequent incubation at 30°C, the culture was filter sterilized through a

0.45- $\mu$ m-pore-size filter (type HA; Millipore Corp., Bedford, Mass.). A nonirradiated culture served as the control. Prophage induction with mitomycin C was performed as previously described with 500 to 1,000 ml of bacterial culture (23).

**Plasmid, chromosomal, and bacteriophage DNA isolation.** Plasmid and chromosomal DNAs were prepared as previously described (14, 26). Phage lysate was concentrated with polyethylene glycol and purified by pelleting through a glycerol step gradient, and phage DNA was extracted as described by Silhavy et al. (24) for large-scale isolation of lambda DNA.

**Restriction enzyme mapping.** All restriction enzymes were obtained from Boehringer Mannheim Biochemicals (Indianapolis, Ind.), and conditions for restriction enzyme reactions were as specified by Maniatis et al. (15).

**Chromosomal insertion.** pE194 DNA linearized at its unique *Xba*I site and *Xba*I-phage DNA fragments were mixed at a molar ratio of 1:3 at a concentration of 80  $\mu$ g/ml and ligated with T4 DNA ligase (Boehringer Mannheim). *L. lactis* subsp. *lactis* protoplasts were transformed with the ligation mixture as previously described (27) and then poured into M17glc agar supplemented with 0.5 M sucrose and 5  $\mu$ g of erythromycin per ml for direct selection of transformants.

**Southern hybridization.** Southern hybridizations were done as described elsewhere (14) on nylon Pall Biodyne membranes. DNA probes were prepared with a nick translation kit (Amersham Corp., Arlington Heights, Ill.) and [ $\alpha$ -<sup>32</sup>P]dCTP (Amersham). Alternatively, probes were prepared with a nick translation kit (Bethesda Research Laboratories, Inc., Gaithersburg, Md.) and biotin-11-dUTP. Biotinylated DNA was detected on the filter by using the Bethesda Research Laboratories DNA detection kit based on the streptavidin-phosphatase system.

### RESULTS

**Prophage characterization.** Following UV or mitomycin C induction of a culture of *L. lactis* subsp. *lactis* IL1403, two isometric phages with different tail lengths were visible in electron micrographs (unpublished data). Extensive investigation with about 300 strains from our collection failed to identify any indicator strain for these temperate phages. Prophage-curing experiments to obtain strains individually lysogenic for these two prophages were also unsuccessful.

\* Corresponding author.

TABLE 1. Strains of *L. lactis* subsp. *lactis*

Designation	Relevant characteristics	Origin
IL1403	Plasmid-free, R <sup>-</sup> /M <sup>-</sup> , carries two prophages designated bIL285 and bIL286	2
IL1734	IL1403 carrying an insertion of pE194 with deletion into bIL285, Em <sup>r</sup>	This work
IL1735	IL1403 carrying a tandem insertion of pE194 with duplication into bIL285, Em <sup>r</sup>	This work
IL1747	IL1403 carrying an insertion of pE194 with duplication into bIL285, Em <sup>r</sup>	This work
IL1750	Like IL1747 but carrying an insertion in a different site of bIL285, Em <sup>r</sup>	This work
IL1946	IL1734 cured of bIL285::pE194, Em <sup>s</sup>	This work

The two prophages were not induced to the same level. When examined by electron microscopy, a dominant phage, designated bIL285, was about 20 times more abundant in the lysate than the second phage, designated bIL286.

**Insertion of pE194 into DNA of *L. lactis* subsp. *lactis* IL1403.** We were unable to transform *L. lactis* subsp. *lactis* with staphylococcal plasmid pE194, although the erythromycin resistance gene of the plasmid, used by Kok et al. (13) to construct the pGK12 vector, is expressed in this species. We thus assumed that pE194 was unable to replicate in *L. lactis* subsp. *lactis* and could be used as a delivery vehicle for chromosomal insertion as previously described by Pozzi and Guild (21) for *S. pneumoniae*. The mixture of the two phage DNAs from the UV-induced IL1403 lysate was digested with *Xba*I endonuclease, for which several restriction sites exist on each phage DNA, and ligated with pE194 DNA linearized by digestion at the *Xba*I site. Because of the higher concentration of the bIL285 phage DNA in the mixture, most recombinant DNA molecules were expected to carry a bIL285 DNA insert. Following transformation of strain IL1403 with the ligation mixture, 500 Em<sup>r</sup> transformants per µg of pE194 DNA were obtained, while no transformants were obtained in a control experiment with *Xba*I-cleaved and religated pE194 DNA. Twelve randomly picked Em<sup>r</sup> transformants were found to lack autonomous plasmid DNA when analyzed by standard procedures. The expected event in these transformants was the insertion of pE194 into the chromosome. This was confirmed by hybridization analysis, which revealed seven different insertional events in 12 transformants. Representative results are shown in Fig. 1.

**Chromosomal insertion of pE194 prevented prophage multiplication.** To demonstrate that pE194 insertion had occurred in prophage DNA, we examined the effect of that insertion on prophage multiplication. The seven different recombinant clones were induced by UV or mitomycin C treatment. DNA was extracted from the induced phages and digested with *Eco*RI, and the electrophoretic pattern was compared with that of a mixture of phage bIL285 and bIL286 DNAs resulting from IL1403 induction. The results are shown in Fig. 2. In the IL1403 lysate, phage bIL285 was about 20 times more abundant than phage bIL286. In contrast, the two phages were produced in about the same amount in the IL1735 lysate. The concentration of bIL286 DNA per milliliter of lysate was the same in the two cases, indicating that only 5% of bIL285 phage were induced during

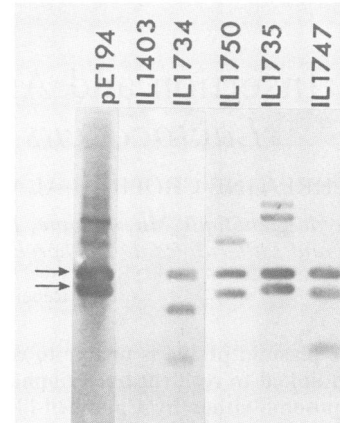

FIG. 1. Southern blot hybridization analysis of DNA from parental and Em<sup>r</sup> transformants. Plasmid pE194 DNA and DNA extracted from the control IL1403 parental strain and Em<sup>r</sup> transformants (IL1734, IL1747, IL1735, and IL1750) were cleaved with *Hpa*II and hybridized with a pE194 DNA probe. *Hpa*II cleaved plasmid pE194 into two fragments (indicated by arrows) with respective sizes of 2,008 and 1,720 base pairs (11). The 2,008-base-pair fragment was retained in all transformants, and the other fragment gave rise to two junction fragments with different sizes depending on the insertion site of pE194 (IL1734, IL1747, and IL1750). The hybridization pattern obtained with strain IL1735, in which four bands are visible, is consistent with the presence of two direct repeats of pE194.

IL1735 UV treatment. In the lysates of all other recombinant clones tested, only phage bIL286 was visible. These results indicate that the insertion of pE194 occurred in prophage bIL285 DNA and prevented its multiplication either totally or partially in strain IL1735, probably depending on the insertion site.

**Mechanism of chromosomal insertion.** To determine the mode of insertion, chromosomal DNA from IL1403 and from the seven different recombinant clones was digested with *Xba*I and hybridized with phage bIL285 DNA. Two types of hybridization patterns were observed (Fig. 3). One recombinant clone designated IL1734 had lost a 4.3-kilobase DNA fragment from prophage bIL285, suggesting that insertion of pE194 had occurred by a double crossing over with deletion

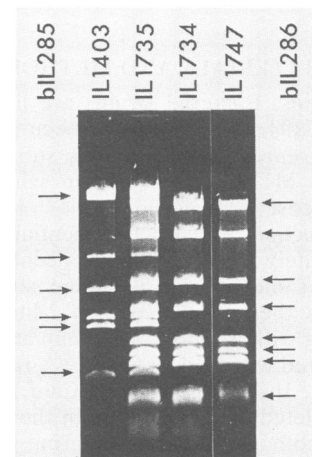

FIG. 2. *Eco*RI digestion patterns of phage DNA from UV-induced lysates of IL1403, IL1735, IL1734, and IL1747. Bands of phage bIL285 or bIL286 are indicated by arrows.

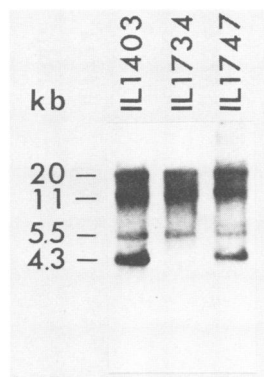

FIG. 3. Southern blot hybridization analysis of DNA from parental IL1403 and  $Em^+$  transformants. DNA extracted from the control IL1403 parental strain and from two representative  $Em^+$  transformants (IL1734 and IL1747) was cleaved with *Xba*I and hybridized with the prophage bIL285 DNA probe. This probe was prepared from phage DNA from a IL1403 UV-induced lysate which mainly consists of bIL285 DNA (Fig. 2). The hybridization patterns are those expected from pE194 integration by a double crossing over with deletion (IL1734) or by a Campbell-like process (IL1747). kb, Kilobases.

(19). The six other clones showed the same pattern as IL1403, suggesting that pE194 integration in these clones had occurred by a Campbell-like process (4). pE194 integration into the prophage bIL285 DNA was confirmed by further hybridization experiments (Fig. 4). Chromosomal DNA from IL1403, from IL1734, and from IL1747 was digested with *Hind*III, which has no restriction site on pE194 (11). Compared with the parental strain IL1403, IL1734 and IL1747 contained one additional band hybridizing with both bIL285 and pE194 probes and corresponding to a bIL285 DNA *Hind*III fragment in which pE194 has been inserted. Following hybridization with a bIL285 probe, IL1747 showed the same pattern as IL1403, whereas IL1734 had lost several bands present in the IL1403 parent. These observations are also consistent with the hypothesis of chromosomal integration by double crossing over with deletion in IL1734 and by a Campbell-like process in IL1747. The proposed paths for chromosomal integration are shown in Fig. 5.

We also measured the stability of the  $Em^+$  marker in the two types of clones after stimulation of the recombination activity of the cells by UV treatment. The stability of integrated pE194 was expected to be lower when the plasmid was inserted between two direct repeats of homologous prophage sequences by Campbell-like recombination than when the plasmid was inserted between nonhomologous sequences by double crossing over with deletion. After UV irradiation ( $40 J/m^2$ ), 5 to 10% of the surviving cells from the six clones thought to result from a Campbell-like recombination were  $Em^+$ . Two randomly picked  $Em^+$  clones still contained prophage bIL285 (hybridization data not shown), indicating that the loss of  $Em^+$  was due to pE194 excision. By contrast, only 1 among 400 (0.25%) of the surviving clones obtained after UV irradiation of IL1734 and thought to result from a double crossing over event was  $Em^+$ . In this clone, designated IL1946, all bands homologous to prophage bIL285 were absent but one (Fig. 6). This remaining band could be either the result of an illegitimate excision or a band of bIL286 sharing homology with bIL285. Results presented in Fig. 6 favor the latter hypothesis and indicate that the strain had been cured of bIL285. In this strain, the loss of  $Em^+$  was the result of prophage induction. These results

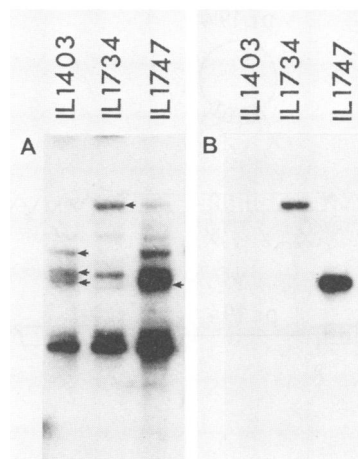

FIG. 4. Southern blot hybridization analysis of DNA from parental IL1403 and  $Em^+$  transformants. DNA extracted from the control IL1403 parental strain, from IL1734, and from IL1747 was digested with *Hind*III and hybridized with a phage bIL285 (A) or pE194 (B) DNA probe. As expected from an integration in prophage bIL285 sequences by double crossing over with deletion, hybridization of chromosomal DNA from IL1734 with bIL285 DNA gave the same pattern as IL1403 except that bands were lost (indicated by arrows in IL1403 lane) and replaced by a new one (indicated by an arrow in IL1734 lane). As expected from an integration by a Campbell-like process, IL1747 gave the same pattern as IL1403 except that one additional band was present (indicated by an arrow in IL1747 lane). Hybridization of chromosomal DNA from IL1734 and IL1747 with pE194 DNA, which is not cleaved by *Hind*III endonuclease, gave a single band. In each case, this band was the same size as the new one which appeared in the hybridization pattern obtained with the bIL285 DNA probe, confirming that pE194 was inserted into bIL285 DNA.

strongly support the hypothesis that pE194 was integrated into the *L. lactis* subsp. *lactis* chromosome either (i) by insertion with duplication or (ii) by double crossing over with deletion.

**Amplification.** In an attempt to select for amplification of the pE194 sequence, we screened the IL1747 strain for resistance to clindamycin, an antibiotic of the macrolide-lincosamide-streptogramin B group. The macrolide-lincosamide-streptogramin B antibiotic resistance conferred by pE194 is induced by erythromycin but not by clindamycin (11). Thus, clindamycin resistance ( $Cl^r$ ) of clones in which  $Em^+$  is partly induced by a small concentration of erythromycin would depend on pE194 copy number and should be increased in clones with amplified pE194 sequences. Strain IL1747 was first partly induced by growth in M17glc broth containing  $0.1 \mu g$  of erythromycin per ml for 5 h and then plated on M17glc agar containing  $0.1 \mu g$  of erythromycin per ml and concentrations of clindamycin ranging from 12 to 200  $\mu g/ml$ . The efficiency of plating compared with a control without clindamycin was  $1 \times 10^{-1}$  to  $5 \times 10^{-3}$ .  $Cl^r$  clones were picked from each concentration of clindamycin and analyzed for amplification. Electrophoretic patterns of their *Xba*I-cleaved chromosomal DNA were compared with those of IL1747 (Fig. 7). Two bands were brighter in the  $Cl^r$  clones, one with a size of 3.7 kilobases corresponding to pE194 and the other with a size of 5.5 kilobases corresponding to the duplicated phage DNA fragment. The level of amplification was determined by densitometry. It increased from one copy in the parental strain to six to nine copies in the strain resistant to 24  $\mu g$  of clindamycin per ml. The

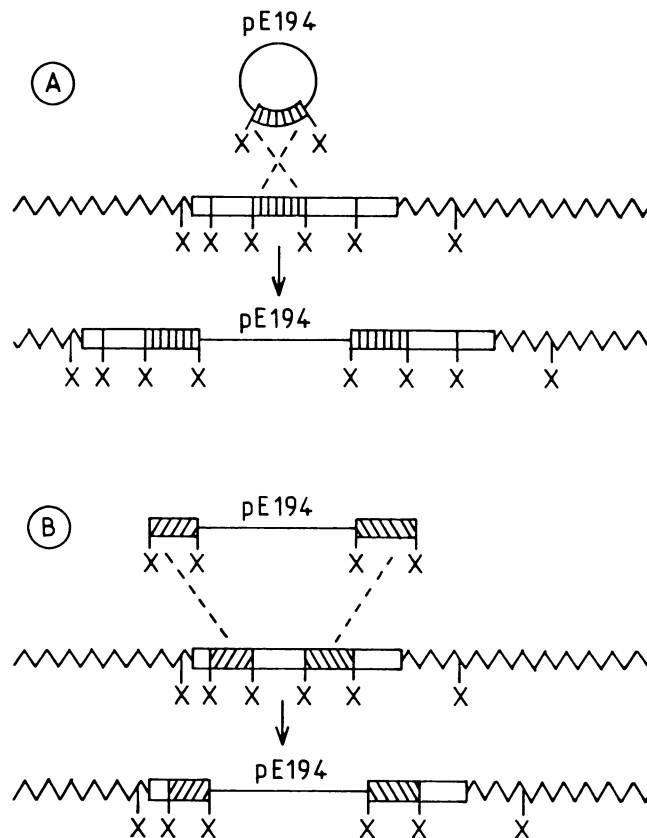

FIG. 5. Paths for integration of pE194 into the chromosome of *L. lactis* subsp. *lactis*. In path A, the recombinant molecule is inserted by a Campbell-like process, resulting in pE194 integration between two direct repeats of the homologous DNA fragment (hatched box). When hybridized with the labeled phage DNA, *Xba*I digests of chromosomal DNA from the parental strain or from its derivative carrying a pE194 insertion show the same pattern. In path B, pE194 linked to two DNA fragments (hatched boxes) is integrated by a double crossing over event. One band has disappeared in the hybridization pattern of the derivative carrying a pE194 insertion when compared with that of the parental strain. *Xba*I sites (designated X) are arbitrarily located. ~, *L. lactis* subsp. *lactis* chromosomal DNA; □, resident prophage DNA.

further increase in clindamycin resistance was not related to an increase in pE194 copy number and probably resulted from mutations. Mutants without detectable amplification were also obtained by direct plating on agar containing high concentrations of clindamycin in the absence of erythromycin induction. To assess the stability of amplification, we grew the IL1747 derivative resistant to 24  $\mu$ g of clindamycin per ml for 26 generations in the absence of antibiotic selection. Among 100 randomly picked colonies, 65 retained their *Cli*<sup>r</sup>, corresponding to a loss of amplification of 1.6% per generation.

#### DISCUSSION

We observed that *L. lactis* subsp. *lactis*, like several other bacterial species, is susceptible to chromosomal integration of foreign DNA. We used this phenomenon to integrate pE194 into the DNA of a resident prophage either by insertion with duplication or by insertion with deletion as

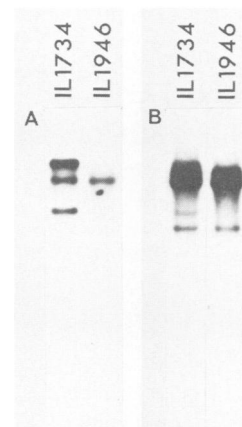

FIG. 6. Southern blot hybridization analysis of DNA from IL1734 and *Em*<sup>r</sup> derivative IL1946. DNA extracted from IL1734 and IL1946 was cleaved with *Xba*I and hybridized with a prophage bIL285 (A) or bIL286 (B) DNA probe. The bIL286 probe was prepared from a UV-induced IL1734 lysate which contains only bIL286 DNA (Fig. 2). All bands homologous to bIL285 in IL1734 but one are absent in IL1946 (A). Assuming that IL1946 had been cured of prophage bIL285, the remaining band could be a band from prophage bIL286 sharing homology with bIL285. This was further demonstrated by hybridization of chromosomal DNAs from IL1734 and IL1946 with a bIL286 probe (B). As expected, one band present in IL1734 was absent in the IL1946 derivative. This indicates that the two prophages share a common region of homology and that IL1946 has been cured of prophage bIL285.

previously described for *B. subtilis* and *S. pneumoniae*. In these latter species, double crossing over with deletion occurs between the chromosome and linear DNA molecules. This can also have occurred in *L. lactis* subsp. *lactis* in which linear molecules formed during ligation could have been introduced following transformation.

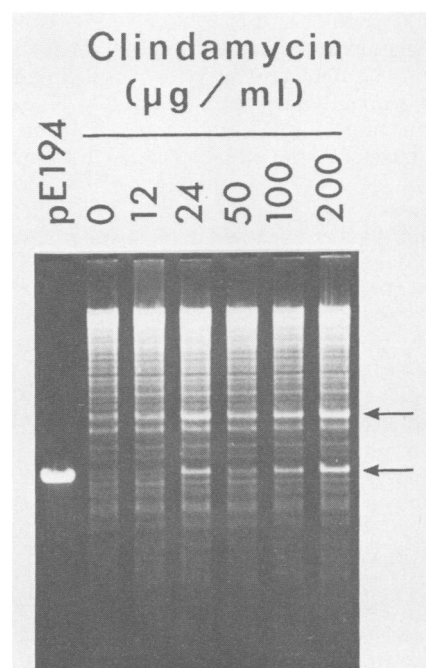

FIG. 7. *Xba*I digestion patterns of pE194 and chromosomal DNA of strain IL1747 grown in the presence of increasing clindamycin concentrations. Amplified bands are indicated by arrows.

Chromosomal integration was not as straightforward in *L. lactis* subsp. *lactis* as in other organisms. Using ligation mixtures prepared from 1 µg of pE194 vector, we obtained 0 to 500 Em<sup>r</sup> transformants in 10 experiments, despite a uniformly high transformation efficiency of *L. lactis* subsp. *lactis* protoplasts with Em<sup>r</sup> plasmid pIL253 (25) DNA (about  $5 \times 10^6$  transformants per µg of DNA). We have no explanation for this variability. Attempts to improve the integration frequency by UV irradiation of the DNA in the ligation mixture (500 J/m<sup>2</sup>) as previously described for *E. coli* (17) or by UV irradiation of the protoplasts before transformation (60 J/m<sup>2</sup>) were unsuccessful. This variability, together with the requirement for a highly efficient transformation protocol, limits the range of applicability of this method to a few *L. lactis* subsp. *lactis* strains. The use of integrative vectors with a conditional replication function could extend the application of chromosomal integration to other lactococcus strains.

Despite the variable integration efficiencies, this technique has proved useful for directed insertion mutagenesis of either the bIL285 or bIL286 (data not shown) prophage and should be applicable for deletion or replacement of undesirable genes in *L. lactis* subsp. *lactis*. Random insertion mutagenesis should also be possible. By transforming *L. lactis* subsp. *lactis* with a mixture of restriction fragments of its chromosome linked to pE194 and selecting for Em<sup>r</sup>, one should obtain random insertion mutants. Experiments under way in this laboratory have established the feasibility of this approach, which could offer the potential advantage of a greater randomness of insertional inactivation over the use of Tn916 (14) or Tn919 (6, 10) in the genetic analysis of the *L. lactis* subsp. *lactis* chromosome.

Finally, chromosomal integration could be used to construct lactococcus strains with stably maintained foreign genes in single or multiple copies, which may be of interest for modifying an organism of considerable industrial importance.

#### ACKNOWLEDGMENTS

We thank Dusko Ehrlich for many discussions during this work and Era Cassuto and Sandy Gruss for critical reading of the manuscript.

#### LITERATURE CITED

- Case, M. E., M. Schweizer, S. R. Kushner, and N. E. Giles. 1979. Efficient transformation of *Neurospora crassa* by utilizing hybrid plasmid. Proc. Natl. Acad. Sci. USA **76**:5259–5263.
- Chopin, A., M. C. Chopin, A. Moillo-Batt, and P. Langella. 1984. Two plasmid-determined restriction and modification systems in *Streptococcus lactis*. Plasmid **11**:260–263.
- Connors, M. J., S. Howard, J. Hoch, and P. Setlow. 1986. Determination of the chromosomal locations of four *Bacillus subtilis* genes which code for a family of small, acid-soluble spore proteins. J. Bacteriol. **166**:412–416.
- Duncan, C. H., G. A. Wilson, and F. E. Young. 1978. Mechanism of integrating foreign DNA during transformation of *Bacillus subtilis*. Proc. Natl. Acad. Sci. USA **75**:3664–3668.
- Fishman, S. E., and C. L. Hershberger. 1983. Amplified DNA in *Streptomyces fradiae*. J. Bacteriol. **155**:459–466.
- Fitzgerald, G. F., C. Hill, E. Vaughan, and C. Daly. 1987. Tn919 in lactic streptococci, p. 238–241. In J. J. Ferretti and R. Curtiss III (ed.), Streptococcal genetics. American Society for Microbiology, Washington, D.C.
- Gutterson, N. I., and D. E. Koshland. 1983. Replacement and amplification of bacterial genes with sequences altered *in vitro*. Proc. Natl. Acad. Sci. USA **80**:4894–4898.
- Haldenwang, W. G., C. D. Banner, J. F. Ollington, R. Losick, J. A. Hoch, M. B. O'Connor, and A. L. Sonenshein. 1980. Mapping a cloned gene under sporulation control by insertion of a drug resistance marker into the *Bacillus subtilis* chromosome. J. Bacteriol. **142**:90–98.
- Hashiguchi, K., A. Tanimoto, S. Nomura, K. Yamane, K. Yoda, S. Harada, M. Mori, T. Furusato, A. Takatsuki, M. Yamasaki, and G. Tamua. 1986. Amplification of the *amyE-tmrB* region on the chromosome in tunicamycin-resistant cells of *Bacillus subtilis*. Mol. Gen. Genet. **204**:36–43.
- Hill, C., C. Daly, and G. F. Fitzgerald. 1985. Conjugative transfer of the transposon Tn919 to lactic acid bacteria. FEMS Microbiol. Lett. **30**:115–119.
- Horinouchi, S., and B. Weisblum. 1982. Nucleotide sequence and functional map of pE194, a plasmid that specifies inducible resistance to macrolide, lincosamide, and streptogramin type B antibiotics. J. Bacteriol. **150**:804–814.
- Janniere, L., B. Niaudet, E. Pierre, and S. D. Ehrlich. 1985. Stable gene amplification in the chromosome of *Bacillus subtilis*. Gene **40**:47–55.
- Kok, J., M. B. M. van der Vossen, and G. Venema. 1984. Construction of plasmid cloning vectors for lactic streptococci which also replicate in *Bacillus subtilis* and *Escherichia coli*. Appl. Environ. Microbiol. **48**:726–731.
- Loureiro Dos Santos, A. L., and A. Chopin. 1987. Shotgun cloning in *Streptococcus lactis*. FEMS Microbiol. Lett. **42**:209–212.
- Maniatis, T., E. F. Fritsch, and J. Sambrook. 1982. Molecular cloning: a laboratory manual, p. 104–106. Cold Spring Harbor Laboratory, Cold Spring Harbor, N.Y.
- Mejean, V., J. P. Claverys, H. Vasseghi, and A. M. Sicard. 1981. Rapid cloning of specific DNA fragments of *Streptococcus pneumoniae* by vector integration into the chromosome followed by endonucleolytic excision. Gene **15**:289–293.
- Michel, B., and S. D. Ehrlich. 1984. Recombination efficiency is a quadratic function of the length of homology during plasmid transformation of *Bacillus subtilis* protoplasts and *Escherichia coli* competent cells. EMBO J. **3**:2879–2884.
- Morrison, D. A., M. C. Trombe, M. K. Hayden, G. A. Waszak, and J. D. Chen. 1984. Isolation of transformation-deficient *Streptococcus pneumoniae* mutants defective in control of competence, using insertion-duplication mutagenesis with the erythromycin resistance determinant of pAMβ1. J. Bacteriol. **159**:870–876.
- Niaudet, B., A. Goze, and S. D. Ehrlich. 1982. Insertional mutagenesis in *Bacillus subtilis*: mechanism and use in gene cloning. Gene **19**:277–284.
- Niaudet, B., L. Janniere, and S. D. Ehrlich. 1985. Integration of linear, heterologous DNA molecules into the *Bacillus subtilis* chromosome: mechanism and use in induction of predictable rearrangements. J. Bacteriol. **163**:111–120.
- Pozzi, G., and W. R. Guild. 1985. Modes of integration of heterologous plasmid DNA into the chromosome of *Streptococcus pneumoniae*. J. Bacteriol. **161**:909–912.
- Raibaud, O., M. Mock, and M. Schwartz. 1984. A technique for integrating any DNA fragment into the chromosome of *Escherichia coli*. Gene **29**:231–241.
- Reyrolle, J., M. C. Chopin, F. Letellier, and G. Novel. 1982. Lysogenic strains of lactic streptococci and lytic spectra of their temperate bacteriophages. Appl. Environ. Microbiol. **43**:349–356.
- Silhavy, T. J., M. L. Berman, and L. W. Enquist. 1984. Experiments with gene fusions, p. 95, 140–141. Cold Spring Harbor Laboratory, Cold Spring Harbor, N.Y.
- Simon, D., and A. Chopin. 1988. Construction of a vector plasmid family and its use for molecular cloning in *Streptococcus lactis*. Biochimie **70**:559–566.
- Simon, D., A. Rouault, and M. C. Chopin. 1985. Protoplast transformation of group N streptococci with cryptic plasmids. FEMS Microbiol. Lett. **26**:239–241.
- Simon, D., A. Rouault, and M. C. Chopin. 1986. High-efficiency transformation of *Streptococcus lactis* protoplasts by plasmid DNA. Appl. Environ. Microbiol. **52**:394–395.
- Stahl, M. L., and E. Ferrari. 1984. Replacement of the *Bacillus subtilis* subtilisin structural gene with an *in vitro*-derived dele-

- tion mutation. *J. Bacteriol.* **158**:411–418.
29. **Terzaghi, B. E., and W. E. Sandine.** 1975. Improved medium for lactic streptococci and their bacteriophages. *Appl. Microbiol.* **29**:807–813.
  30. **Vasseghi, H., and J. P. Claverys.** 1983. Amplification of a chimeric plasmid carrying an erythromycin-resistance determinant introduced into the genome of *Streptococcus pneumoniae*. *Gene* **21**:285–292.
  31. **Vasseghi, H., J. P. Claverys, and A. M. Sicard.** 1981. Mechanism of integrating foreign DNA during transformation of *Streptococcus pneumoniae*, p. 137–154. *In* M. Polsinelli and G. Mazza (ed.), *Transformation 1980*. Costwold, Oxford.
  32. **Vijayakumar, M. N., S. D. Priebe, G. Pozzi, J. M. Hageman, and W. R. Guild.** 1986. Cloning and physical characterization of chromosomal conjugative elements in streptococci. *J. Bacteriol.* **166**:972–977.
  33. **Wilson, F. E., J. A. Hoch, and K. F. Bott.** 1981. Genetic mapping of a linked cluster of ribosomal ribonucleic acid genes in *Bacillus subtilis*. *J. Bacteriol.* **148**:624–628.
  34. **Young, M.** 1983. The mechanism of insertion of a segment of heterologous DNA into the chromosome of *Bacillus subtilis*. *J. Gen. Microbiol.* **129**:1497–1512.
  35. **Young, M.** 1984. Gene amplification in *Bacillus subtilis*. *J. Gen. Microbiol.* **130**:1613–1621.