

Identification of DNA Sequences Recognized by VirF, the Transcriptional Activator of the *Yersinia yop* Regulon

PIERRE WATTIAU AND GUY R. CORNELIS*

Microbial Pathogenesis Unit, International Institute of Cellular and Molecular Pathology and Faculté de Médecine, Université Catholique de Louvain, UCL 74-49, B-1200 Brussels, Belgium

Received 27 December 1993/Accepted 18 April 1994

Pathogenic bacteria of the genus *Yersinia* harbor a 70-kb plasmid required for virulence. The plasmid-encoded virulence proteins of yersiniae are positively regulated at the transcriptional level by the product of the *virF* gene, the key activator of the system. *virF* encodes a DNA-binding protein related to the AraC family of transcriptional activators. The VirF protein from *Yersinia enterocolitica* is a 30-kDa protein that forms dimers in vitro and that specifically binds to the promoter region of VirF-regulated genes. In this work, we determined the sequences of eight VirF-binding sites from four different genes, by DNase I or hydroxyl radical footprinting. The protected regions, about 40 bases long, were aligned, and a number of conserved residues were identified. A 13-bp sequence resembling TTTTaGYcTtTat (in which nucleotides conserved in $\geq 60\%$ of the sequences are in uppercase letters and y indicates C or T) appeared, either isolated or as an inverted repeat in each of the eight sites.

Pathogenic strains of the genus *Yersinia* harbor a highly conserved plasmid called pYV. The presence of this plasmid prevents growth of its host at 37°C at low Ca²⁺ concentrations, a phenotype referred to as Ca²⁺ dependency or low-Ca²⁺ response (for a review, see reference 36). The pYV plasmid also encodes a set of at least 11 secreted proteins called Yops (for reviews, see references 10 and 13), an adhesin called YadA (35), and a lipoprotein called YlpA (6). YopE is an important virulence factor responsible for a cytotoxic effect on host cells (32). Its secretion requires SycE, a specific chaperone encoded by the gene lying next to *yopE* (39). YopH belongs to the phosphotyrosine phosphatase protein family and has been shown to dephosphorylate some macrophage proteins (2, 15). YopB and YopD are thought to form channel structures involved in YopE translocation into the cytoplasm of eucaryotic target cells (16). The *yop* genes are scattered around the pYV plasmid, either individually as *yopE* and *yopH* or assembled in operons. The largest operon encoding Yops is the 4.6-kb operon consisting of *lcrGVH-yopBD* (1, 16, 29). It encodes YopB and YopD as well as LcrG, LcrV, and LcrH, three proteins involved in the low-Ca²⁺ response (1, 3, 16, 29, 30, 34). The pYV plasmid also encodes export machinery of a new type devoted to Yop secretion (25). The secretion genes called *ysc* are distributed on pYV in loci *virA*, *virB*, and *virC*. Locus *virC* consists of a single operon containing the 13 *yscA* to *yscM* genes (25). The *yop*, *yadA*, and *ylpA* genes as well as the *virC* operon form the *yop* regulon (11). Transcription of this regulon is triggered by VirF, a 30-kDa DNA-binding protein of the AraC family (8). VirF is produced only at 37°C, which may account for the thermodependent expression of the *yop* regulon. However, additional factors are required to initiate transcription of the VirF target genes, because expression of VirF at low temperatures is not sufficient to promote transcription of these genes (19). VirF forms dimers in vitro, and it has been shown to bind the *yopH* promoter region (19). In this paper, we

report our further investigation of the DNA-binding sites of VirF. We focused on the promoter regions from four different transcription units previously shown to be regulated by VirF: *yopE* (17), *yopH* (8, 9, 19), *lcrGVH-yopBD* (1), and the *virC* operon (19, 25).

MATERIALS AND METHODS

Purification of VirF. VirF was purified to homogeneity from an overproducing *Escherichia coli* strain as described by Lambert de Rouvroit et al. (19).

Plasmids and oligonucleotides. Plasmids are listed in Table 1. pPW41 carries a 280-bp DNA fragment spanning nucleotides -209 to +18 relative to the *lcrG* transcriptional start identified previously in *Yersinia pestis* (29). This fragment was obtained by PCR. Amplification was realized with primers MIPA47 (TGGGTACCTATCTGTATGGCAATG) and MIPA48 (GG AAGCTTTGGGAAGATTTTCATAAT). The PCR protocol was as follows (the heating rate was 48°C min⁻¹ for all incubations unless otherwise indicated): 1 cycle of 5 min at 93°C, 5 min at 40°C (heating rate, 10°C min⁻¹), and 5 min at 70°C followed by 25 cycles of 1 min at 93°C, 2 min at 52°C, and 2 min at 70°C followed by 1 cycle of 1 min at 93°C, 2 min at 52°C, and 10 min at 70°C. The resulting fragment was inserted into the *Hind*III-*Asp* 718 sites of pBlueScriptII KS-.

The other oligonucleotides used in this work were MIPA9 (GGGCAGTGATGTAG) and MIPA39 (CCATCCAGCG GCGAAATA).

Nonradioactive band shift assays. Approximately 1 µg of restricted plasmid DNA was incubated with VirF at concentrations ranging from 0 to 1 µM for 15 min at room temperature in 30 µl of binding buffer (10 mM Tris-HCl [pH 7.4], 50 mM KCl, 1 mM EDTA, 5% glycerol, 0.05% Nonidet P-40). After addition of 10 µl of loading buffer (0.05% bromophenol blue, 0.25 mg of bovine serum albumin ml⁻¹), the samples were electrophoresed in a low-ionic-strength (6.7 mM Tris-HCl [pH 7.5], 3.3 mM sodium acetate, 1 mM EDTA) 5% acrylamide gel. The gel was then stained in a 2-mg liter⁻¹ ethidium bromide solution.

DNA labeling. End labeling of DNA for footprinting assays was performed by filling in 3'-recessive ends with Klenow

* Corresponding author. Mailing address: Microbial Pathogenesis Unit, Ave. Hippocrate, 74, UCL 74-49 B-1200 Brussels, Belgium. Phone: 32 2 7647449. Fax: 32 2 7647498. Electronic mail address: cornelis@mipa.ucl.ac.be.

TABLE 1. Bacterial plasmids used in this study

Plasmid	Characteristics	Reference
pBC19R	pTZ19R (Pharmacia) + <i>ori</i> _{TRK2}	6
pCL12	pIC20H + <i>Dra</i> I- <i>Sau</i> 3AI of a pYVe227 containing the <i>yopH</i> promoter	This work
pGCS652	pTZ19R (Pharmacia) + <i>Eco</i> RI- <i>Bam</i> HI of pYVe227 containing the <i>virC</i> promoter	This work
pIC20H	<i>ori</i> _{pBR322} <i>lacZ'</i> <i>bla</i>	23
pPW1	pBC19R + <i>Xho</i> I- <i>Xho</i> I fragment of pYVe227 containing <i>yopE</i> and <i>syncE</i>	This work
pPW2	pBC19R + <i>Eco</i> RI- <i>Hind</i> III of pPW2S	This work
pPW2S	pSELECT-1 (Promega) + <i>Eco</i> RI- <i>Xho</i> I of pYVe227 containing <i>yopE</i>	39
pPW41	pBlueScriptII KS- (Stratagene) + <i>lcrG</i> promoter of pYVe227	This work

enzyme in the presence of radiolabeled nucleotides as described by Maniatis et al. (22). Alternatively, end-labeled DNA fragments were obtained by extension of a 5'-labeled oligonucleotide annealed with single-stranded DNA containing the region of interest: 5 ng of ³²P-labeled oligonucleotide purified by chromatography on Sephadex G-50 (Pharmacia) was mixed with 1 µg of single-stranded phagemid DNA. For annealing, the mixture was heated for 5 min at 70°C and then cooled in 15 min to 25°C in 42 µl of pol I buffer (0.11 M potassium phosphate, 5.5 mM MgCl₂, 20 mg of bovine serum albumin ml⁻¹, pH 7.4). The annealed mixture was then supplemented with 1.5 µl of 0.1 M dithiothreitol, 5 µl of a deoxynucleotide mix (dATP, dCTP, dGTP, and dTTP, 1 mM each), and 2 U of Klenow enzyme (Boehringer). After 15 min at 22°C, the mixture was heated for 5 min at 65°C, extracted twice with phenol and once with chloroform, and precipitated with ethanol.

Footprinting assays. DNase I protection assays were carried out essentially as described by Gallas and Schmitz (14). Binding was performed by incubating end-labeled DNA with purified VirF at various concentrations in 50 µl of a mixture of 10 mM Tris-HCl (pH 7.9), 50 mM KCl, 6.25 mM MgCl₂, 0.05 mM EDTA, 8.5% glycerol, 2% polyvinyl alcohol, and 20 µg of poly(dI · dC) ml⁻¹. Unless specified, the binding temperature was 20°C. After 15 min, 50 µl of a 5 mM CaCl₂-10 mM MgCl₂ solution as well as 10 to 20 mU of DNase I (Boehringer) was added. After 1 min of digestion at 20°C, the reaction was stopped with 100 µl of DNase stop solution (200 mM NaCl, 20 mM EDTA, 1% sodium dodecyl sulfate). The samples were extracted with phenol and chloroform and precipitated with ethanol in the presence of 10 µg of tRNA as a carrier. The fragments were resuspended in 5 to 10 µl of formamide dye mix and electrophoresed on a 6% acrylamide-8 M urea sequencing gel, together with mixtures for sequencing reactions of the same DNA.

Hydroxyl radical footprinting (HRFP) was performed essentially as described by Tullius and Dombroski (38). End-labeled DNA was incubated at 20°C with various concentrations of the VirF protein in 170 µl of a mixture containing 0.1 mg of bovine serum albumin ml⁻¹, 20 µg of poly(dI · dC) ml⁻¹, 6 µM EDTA, 3 mM KCl, 0.06 mM CaCl₂, and 0.6 mM bis-Tris-HCl, pH 7.9. After 15 min, 10 µl of 20 mM sodium ascorbate, 10 µl of 0.2 mM (NH₄)₂Fe(SO₄)₂-0.4 mM EDTA, and 10 µl of 0.6% H₂O₂ were successively added. Reactions were carried out for

150 s at 20°C and stopped by addition of 20 µl of 0.1 M thiourea and 25 µl of 3 M sodium acetate. The fragments were then extracted as described for the DNase I footprinting assay.

RESULTS

Identification of two VirF-binding sites in the *yopE* promoter region. The *yopE* gene was cloned in a multicopy vector with either 890 or 290 bp of the upstream DNA region, yielding pPW1 and pPW2, respectively (Fig. 1A). pPW1 expresses both *yopE* and *syncE* from their own promoters, as was observed in complementation studies (data not shown). DNA from these plasmids was investigated in a nonradioactive bandshift experiment performed with purified VirF. After restriction with both *Eco*RI and *Pst*I, the fragments were incubated with different concentrations of VirF and run on an agarose gel in a low-ionic-strength buffer. In the presence of 0.5 µM VirF, the 580-bp *Eco*RI-*Pst*I fragment common to both plasmids was shifted whereas the other fragments were not (Fig. 1B). At 1 µM VirF, two retarded bands were visible. This gradual shift suggested that at least two different VirF molecules could bind to the promoter region, but with different affinities.

The binding of VirF to the *yopE* promoter was then studied by the DNase I protection technique (14). An end-labeled DNA strand was obtained by primer extension from labeled oligonucleotide MIPA9 annealed with single-stranded pPW1 (Fig. 2). Several regions appeared to be protected by VirF from DNase I digestion (Fig. 1C). The region between nucleotides -112 and -75 relative to the *yopE* transcriptional start was particularly well protected. A second DNA region, spanning nucleotides -67 and -29, was weakly but nevertheless clearly protected. The central residues of this region were hypersensitive to DNase I cleavage (Fig. 1C).

These footprinting results thus revealed the existence of two distinct VirF-binding sites, as was suggested by the band shift assay data. The strongest binding site was the most distal relative to the *yopE* transcriptional start and was called E1, while the weaker binding site was called E2. It should be noticed that E1 could serve to regulate transcription of the *syncE* gene, which is oriented in opposite orientation compared to *yopE* (Fig. 2). Expression of *syncE* was indeed shown to require VirF (39). Figure 1C does not clearly show the upstream limit of E1. This upstream limit of E1 was fixed to -75 because longer exposures of the same gel allowed to detect faint digestion bands which were present only in the absence of VirF (data not shown).

Footprinting analysis of the *yopH* promoter. VirF binds the DNA region localized between nucleotides -64 and -30 relative to the transcriptional start of *yopH* (19). Gel retardation experiments revealed a single band shift at low VirF concentrations and two band shifts at high VirF concentrations (19). We further investigated the binding of VirF in the *yopH* promoter region by both DNase I footprinting and HRF. We isolated a 230-bp *Bgl*III-*Pst*I restriction fragment derived from plasmid pCL12 (Fig. 2) and labeled the 3'-recessive *Bgl*III end with Klenow fragment. The fragment was then incubated with increasing amounts of VirF and subjected to cleavage.

As shown in Fig. 3, the DNase I footprinting was quite complex: more than 100 residues lying in the central part of the DNA fragment were clearly modified in their digestion profiles because of the presence of VirF. A strong binding site spans nucleotides -63 to -19. This site, already described by Lambert de Rouvroit et al. (19), will be referred to as the H1 site. Another region extending from nucleotide -134 to -94 and called H2 was also protected by VirF. The central residues of both sites were hypersensitive to DNase I cleavage in the

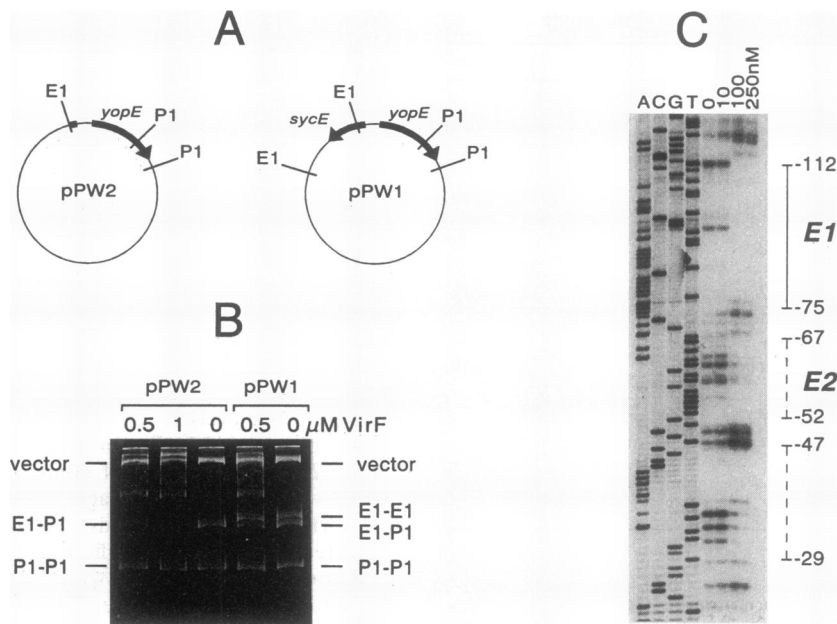

FIG. 1. Binding of VirF to the *yopE* promoter. (A) *EcoRI-PstI* restriction map of plasmids pPW1 and pPW2. (B) Nonradioactive band shift assay. *EcoRI-PstI*-digested plasmids were incubated with VirF at the concentrations indicated, run on a 5% acrylamide gel, and revealed by ethidium bromide staining. Letters in the margins refer to the restriction fragments derived from the plasmids shown in panel A. (C) DNase I footprinting. End-labeled DNA derived from extension of oligonucleotide MIPA9 annealed with single-stranded pPW1 was incubated with VirF at the concentrations indicated on the top. After partial DNase I digestion, the samples were run on an 8 M urea-6% acrylamide gel together with mixtures for Sanger sequencing reaction of the same DNA. Numbers on the right indicate positions with respect to the *yopE* transcription start (13). A solid bar in the margin indicates a strongly protected region, whereas a dashed bar indicates a weakly protected region. E1 and E2 indicate the VirF-binding sites localized in this promoter.

presence of VirF. H1 was already protected at 50 nM VirF, whereas H2 was not. Thus, VirF first occupies H1 and subsequently binds H2 as its concentration increases. When DNA was incubated at 250 nM VirF, the digestion pattern of

nucleotides -62 to -93 was also modified: two short regions were protected, separated by hypersensitive bonds. As will be discussed later, this third region of the *yopH* promoter is likely to be altered in its DNase I digestion pattern as the consequence of a local DNA bent induced by VirF binding to the neighboring H1 and H2. The nucleotide sequence of this region does not contain any sequence resembling the other VirF-binding sites, and it is too short to contain such a site.

HRFP gave two complementary pieces of information. First, four stretches of 4 to 6 nucleotides were protected in both H1 and H2 as the consequence of VirF binding (not clearly visible on Fig. 3B). Thus, from the 40 nucleotides constituting each site, only 20 to 24 were tightly associated with VirF. Second, as was already observed for the DNase I footprinting profiles, the central residue of H2 was hypersensitive to cleavage by hydroxyl radicals. By contrast, the central residue of H1 was not hypersensitive to hydroxyl radicals.

This observation of two different VirF-binding sites in the *yopH* promoter was in agreement with the gel retardation patterns described previously (19). DNase I footprinting of the *yopH* promoter was also performed at 37°C but gave results similar to those obtained at room temperature (data not shown). Thus, as for *yopE*, the two different methods suggest that the *yopH* promoter contains at least two VirF-binding sites and that these sites have different affinities for the activator.

Footprinting analysis of the *virC* promoter. DNase I footprinting of the *virC* promoter was conducted with an end-labeled product derived by extension of oligonucleotide MIPA39 annealed with single-stranded DNA from plasmid pGCS652 (Fig. 2). As shown in Fig. 4A, a first VirF-binding region appeared between nucleotides -36 and -73 relative to the *virC* transcriptional start. When the VirF concentration reached 100 nM, the region spanning nucleotides -29 to -6 of

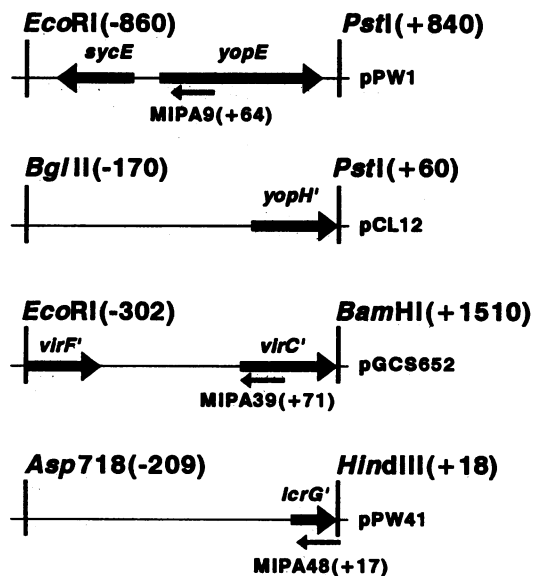

FIG. 2. Map of the plasmids used in the footprinting assays. Numbers in parentheses correspond to positions relative to transcriptional starts. MIPA9, MIPA39, and MIPA48 are primers with complementarity to the single-stranded DNA derived from phagemids pPW1, pGCS652, and pPW41, respectively. Genes are identified by thick arrows.

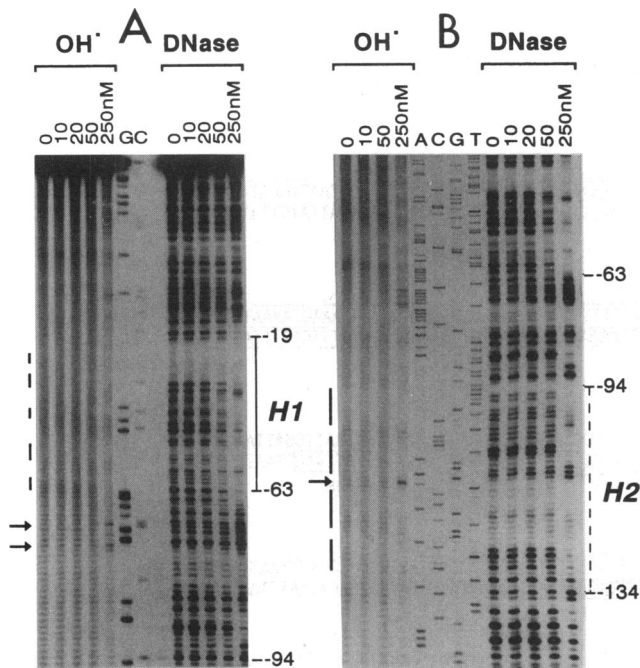

FIG. 3. Footprint analysis of the *yopH* promoter. A 220-bp *Bgl*II-*Pst*I restriction fragment from plasmid pCL12 was labeled at the *Bgl*II end, incubated with VirF at the concentrations indicated, and subjected to footprinting with either hydroxyl radicals (OH[•]) or DNase I. The solid bar in the margin indicates the strongly protected region, whereas the dashed bars indicate the weakly bound region. Thick vertical lines indicate protected regions, while horizontal arrows point to hypersensitive nucleotides observed in HRFP. H1 and H2 indicate the VirF-binding sites localized in this promoter. Numbers in the margin indicate positions with respect to the transcription start point. (A) Extended run. G and C indicate the Maxam and Gilbert sequencing reactions conducted with the same DNA fragment. (B) Short run. Lanes A, C, G, and T contain unrelated sequencing reactions used as molecular weight markers in this experiment.

the *virC* promoter was also protected from DNase I cleavage. Thus, as already observed for *yopE* and *yopH*, the *virC* promoter contains two neighboring sites recognized by VirF, one with strong affinity (C1), already detectable at low VirF concentrations, and one with low affinity (C2) detectable only at VirF concentrations of 100 nM or more.

Footprinting analysis of the *lcrG* promoter. To investigate the binding of VirF to the promoter of the *lcrGVH-yopBD* operon, we amplified by PCR a DNA region corresponding to the *lcrG* promoter of *Yersinia enterocolitica* W22703. PCR was conducted with primers MIPA47 and MIPA48 derived from the sequence of *lcrG* from *Y. pseudotuberculosis* (1). The amplified DNA fragment was cloned on pBlueScriptII KS-, giving pPW41 (Fig. 2). Single-stranded pPW41 was used as a template to produce end-labeled DNA by extension from labeled MIPA48. According to the footprinting analysis, VirF protected a 45-bp region starting at nucleotide -64 and ending at nucleotide -20 (Fig. 4B). Because this region contained a hypersensitive bond at nucleotide -35, we decided to distinguish two sites that we called G1 and G2. G1 extends from nucleotides -64 to -38, and G2 begins at -33 and ends at -20.

Alignment of the sequences recognized by VirF. Alignment of the eight sites that were protected by VirF did not allow us to infer a clear consensus sequence. We thus focused on the

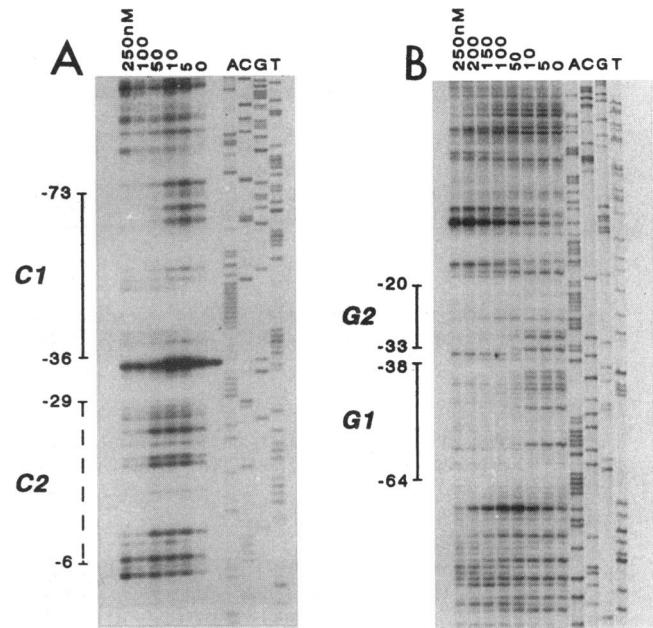

FIG. 4. Footprinting analysis of the *virC* and *lcrG* promoters. End-labeled DNA derived from extension of oligonucleotide MIPA39 (for *virC*) or MIPA48 (for *lcrG*) annealed, respectively, with single-stranded pGCS652 or pPW41 was incubated with VirF at the concentrations indicated. After partial DNase I digestion, the samples were run on an 8 M urea-6% acrylamide gel together with mixtures for Sanger sequencing reactions of the corresponding DNA and primers. Numbers on the left indicate positions with respect to the transcription start points (25, 29). (A) *virC* footprinting. C1 is a strong VirF-binding site; C2 is a weaker site. (B) *lcrG* footprinting. G1 and G2 indicate the VirF-binding sites localized in this promoter.

high-affinity sites C1, E1, H1, and G1. Again, no common motif could be identified in these four sites, but C1 and E1 contain an identical 11-bp sequence (AATTTTAGCCT). Since the probability of encountering a given 11-bp sequence is very low ($P = 2 \times 10^{-7}$), we postulated that this sequence could be part of the motif recognized by VirF. Because VirF is a dimer and is presumed to bind DNA as a dimer, its DNA-binding sites are expected to be composed of two half-sites. These half-sites could be organized either in direct repeat orientation or in inverted repeat orientation, but they should lie on the same face of the DNA helix so that they could be bound by a single VirF dimer. We thus studied carefully all the protected sequences in order to find such motifs including or overlapping the 11-bp sequence described above. Although not perfect, potential inverted repeats were detected not only within E1 and C1 but also within G1 and H1. The inverted repeats that we identified consist of two 13-bp sequences separated by A or T (Fig. 5 and Table 2). G2 and the low-affinity VirF binding sites C2, E2, and H2 did not contain DNA sequences sharing a reasonable degree of similarity to this 27-bp global motif. However, the 13-bp sequence corresponding to half the global motif could be identified in each of the last three sites. In E1, an additional 13-bp sequence was also found next to the inverted repeat. Our interpretation of these findings is that the high-affinity VirF-binding sites consist of two 13-bp half-sites repeated in inverted orientation, whereas the low-affinity sites contain only one half-site. We aligned all the putative half-sites localized within the DNA regions bound by VirF and derived the consensus sequence TTTTaGYcTtTat (Table 2).

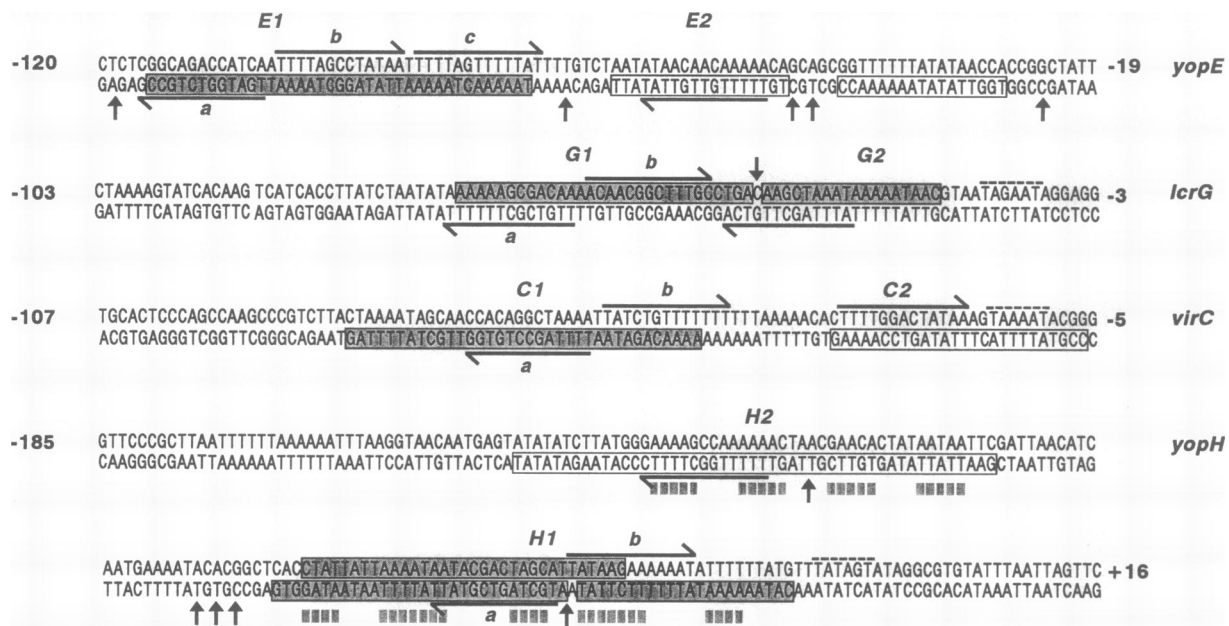

FIG. 5. Nucleotide sequences of the DNA regions recognized by VirF. Regions that were strongly bound by VirF in the DNase I footprinting assays are included in gray boxes, whereas the regions that were weakly bound are in white boxes. Protected nucleotides identified by HRFP in the *yopH* promoter are underlined by thick dashed lines. Hypersensitive bonds are pointed out by vertical arrows. For the upper strand of the *yopH* promoter, the footprinting data are from the work of Lambert de Rouvroit et al. (19). Horizontal lines with arrowheads correspond to the 13-base consensus motif found in the protected regions. -10 boxes are overlined by dashed lines. Numbers on the sides refer to positions relative to the transcriptional starts determined previously (13, 24, 25, 29).

DISCUSSION

VirF, like many regulators described recently, is a member of the AraC family of transcriptional activators. This family includes DNA-binding proteins involved in different processes such as metabolic pathways (18, 26, 37, 40) or pathogenesis (4, 8, 33). None of these regulators has been studied as intensively as AraC, the regulator of genes involved in arabinose catabolism which became an archetype in transcriptional regulation. The most remarkable property of AraC is its ability to regulate the *araBAD* operon either positively or negatively. The AraC binding sites involved in *araBAD* regulation are two adjacent half-sites called *araI*₁ and *araI*₂ and a half-site located 210 bp

upstream from *araI* and called *araO*₂ (12, 28). In the absence of arabinose, *araI*₁ and *araO*₂ are bound by a single AraC dimer, resulting in a noninducing, DNA-looping state (12, 21). In the presence of arabinose, AraC undergoes a conformational change that strongly reduces its capacity to bind half-sites spaced by more than one helical turn (5). Instead, arabinose-complexed AraC binds the two adjacent *araI*₁ and *araI*₂ half-sites and transcription of *araBAD* occurs (20, 21). The dimeric AraC protein is thus flexible in the absence of arabinose and almost rigid in its presence. Although it is clear that a homodimer of AraC binds to two half-sites, the consensus sequence derived from these sites and their symmetry could not be clearly established. Carra and Schleif (5) ultimately resolved the symmetry issue of the *araI* site by showing that AraC can bind to *araI*₁ half-sites paired either in direct repeat orientation or in inverted repeat orientation. Recent studies from the same laboratory (31) also showed that transcription activation by AraC strictly requires that the regulator be positioned at an exact distance from the transcription start, overlapping the RNA polymerase binding region.

The present study of the binding of VirF to the promoter regions of four target genes revealed several common features. In most cases VirF did not bind to only one site but rather bound to two sites. Binding to these sites generally occurred in two steps. A first series of sites were bound by VirF at low concentrations, 0.5 μ M in the nonradioactive band shift assay and 50 nM in footprinting assays. At higher concentrations, VirF progressively contacted a second series of sites. We explain the gradual protection observed in our footprinting assays by the preferential binding of VirF to sites that are constituted of two inverted repeat half-sites. Hence, isolated half-sites or sites in which one half-site is severely degenerated will be bound by VirF with weaker affinity and only when all the strong sites are already filled.

TABLE 2. Alignment of the half-sites

Half-site	Sequence
E1-aTGATGGTCTGCCG
E1-bTTTAGCCTATAA
E1-cTTTAGTTTTAT
G1-aTTGTCGCTTTTT
G1-bACAACGGCTTTGA
C1-aTTTAGCCTGGG
C1-bTATCTGTTTTTT
H1-aTGCTAGTCGTATT
H1-bTATAAGAAAAAT
E2TTTTGTTGTTAT
G2ATTTAGCTTGTCA
C2TTTGGACTATAA
H2TTTTGGCTTTTC
ConsensusTTTTaGYcTtTat ^a

^a Derived from all of the identified half-sites. Nucleotides conserved in $\geq 60\%$ of the sequences are in uppercase letters; others are in lowercase letters. y, C or T.

The existence of strong and weak VirF-binding sites within the *yop* promoters is not evidence in favor of a simple, one-way regulation mechanism. In particular, the presence of clear footprinting regions at positions very distant from the transcriptional starts suggests that transcription activation does not result simply from binding of VirF to its target sites and brings to mind the AraC model. By analogy to the AraC system, distant half-sites found in the VirF-regulated promoters could bind VirF together, generating DNA loops as do the *araI*₁ and *araO*₂ half-sites (12). According to this hypothesis, the binding of VirF may affect DNase I cleavage of unbound, looped DNA regions unrelated to the consensus sequence. In the *yopH* promoter, hypersensitive bonds appeared between the H1 and H2 sites. In the *yopE* promoter, hypersensitive bonds were observed between the E1 and E2 sites and in the middle of E2.

Like the *yop* regulon genes, *virF* is thermoinduced. This thermoinduction of the activator could explain the thermodependent expression of the regulon. However, expression of a *yopE-lacZ* fusion remains thermodependent in a *Y. pestis* strain producing the activator constitutively (17). Accordingly, VirF is unable to activate transcription of *yopH* at low temperatures in *Y. enterocolitica* (19). Thus, in vivo, VirF is active only at 37°C. In vitro, VirF binds to the H1 site of the *yopH* promoter at room temperature and at 37°C. By analogy with the AraC model, temperature could induce a conformational change in the VirF protein and modify its affinity for the different sites. This simple model is, however, contradicted by the fact that we observed the same footprint of the *yopH* promoter at 25 and 37°C. Moreover, it does not take into account the role of YmoA, a histone-like protein previously shown to be required for normal regulation of the *yop* regulon genes (7). In *ymoA* mutants, transcription of the *yopH* promoter can be induced by VirF at low temperatures (19). These observations suggest that the target of VirF, rather than VirF itself, is modified by temperature. To take this element into account, one should perform future footprints in vivo rather than in vitro on phenol-extracted DNA.

In conclusion, according to our previous genetic studies and to the present data, VirF binds to multiple sites in the promoter region of *yopH*, *yopE*, *virC*, and *lcrG*. There is a clear correlation between the VirF concentration and the VirF-binding site occupancy. These sites seem to be made of repeated 13-bp half-sites. The nucleotide sequences of these half-sites are poorly conserved, and the deduction of a consensus sequence is not easy. This consensus remains thus questionable. The situation is very reminiscent of that of AraC. We hypothesize that, like for AraC, transcriptional control of VirF-regulated genes involves the binding of VirF to several sites. In view of the complexity of the system, as for AraC, one should now concentrate on one VirF-regulated promoter and modify both the nature of the sites and their positions. The *virC* promoter is probably a good candidate to carry out this study because there is no close divergent promoter and because an operon involved in secretion must be among the first ones to be expressed.

ACKNOWLEDGMENTS

We are grateful to Alvydas Mikulskis for a critical reading of the manuscript.

P.W. was the recipient of a fellowship from the Belgian Institut pour l'Encouragement de la Recherche Scientifique dans l'Industrie et l'Agriculture. This work was supported by grants from the Belgian Fonds National de la Recherche Scientifique Médicale (convention 3.4627.93), the Belgian Fonds National de la Recherche Scientifique (crédit aux chercheurs 1.5.025.94F), and the Belgian program on interuniversity poles of attraction initiated by the Belgian State, Prime Minister's Office, Science Policy Programming.

REFERENCES

- Bergman, T., S. Håkansson, Å. Forsberg, L. Norlander, A. Macellaro, A. Bäckman, I. Bölin, and H. Wolf-Watz. 1991. Analysis of the V antigen *lcrGVH-yopBD* operon of *Yersinia pseudotuberculosis*: evidence for a regulatory role of LcrH and LcrV. *J. Bacteriol.* **173**:1607-1616.
- Bliska, J. B., K. Guan, J. E. Dixon, and S. Falkow. 1991. A mechanism of bacterial pathogenesis: tyrosine phosphate hydrolysis of host proteins by an essential *Yersinia* virulence determinant. *Proc. Natl. Acad. Sci. USA* **88**:1187-1191.
- Burrows, T. W., and G. A. Bacon. 1960. V and W antigens in strains of *Pasteurella pseudotuberculosis*. *Br. J. Exp. Pathol.* **41**:38-44.
- Caron, J., L. M. Coffield, and J. R. Scott. 1988. A plasmid-encoded regulatory gene, *ms*, required for the expression of the CS1 and CS2 adhesins of enterotoxigenic *Escherichia coli*. *Proc. Natl. Acad. Sci. USA* **86**:963-967.
- Carra, J. H., and R. F. Schleif. 1993. Variation of half-site organization and DNA looping by AraC protein. *EMBO J.* **12**:35-44.
- China, B., T. Michiels, and G. R. Cornelis. 1990. The pYV plasmid of *Yersinia* encodes a lipoprotein YlpA, related to TraT. *Mol. Microbiol.* **9**:1585-1593.
- Cornelis, G., C. Sluiter, I. Delor, D. Geib, K. Kaniga, C. Lambert de Rouvroit, M. P. Sory, J. C. Vanooteghem, and T. Michiels. 1991. *ymoA*, a *Yersinia enterocolitica* chromosomal gene modulating the expression of virulence functions. *Mol. Microbiol.* **5**:1023-1034.
- Cornelis, G., C. Sluiter, C. Lambert de Rouvroit, and T. Michiels. 1989. Homology between VirF, the transcriptional activator of the *Yersinia* virulence regulon, and AraC, the *Escherichia coli* arabinose operon regulator. *J. Bacteriol.* **171**:254-262.
- Cornelis, G., J. C. Vanooteghem, and C. Sluiter. 1987. Transcription of the *yop* regulon from *Y. enterocolitica* requires trans acting pYV and chromosomal genes. *Microb. Pathog.* **2**:367-379.
- Cornelis, G. R. 1992. *Yersiniae*, finely tuned pathogens, p. 231-265. In E. Hormaeche, C. W. Penn, and C. J. Smyth (ed.), *Molecular biology of bacterial infection*. SGM symposium no. 49. Cambridge University Press, Cambridge.
- Cornelis, G. R., T. Biot, C. Lambert de Rouvroit, T. Michiels, B. Mulder, C. Sluiter, M. P. Sory, M. Van Bouchaute, and J. C. Vanooteghem. 1989. The *Yersinia yop* regulon. *Mol. Microbiol.* **3**:1455-1469.
- Dunn, T. M., S. Hahn, S. Ogden, and R. F. Schleif. 1984. An operator at -280 base pairs that is required for expression of *araBAD* operon promoter: addition of DNA helical turns between the operator and promoter cyclically hinders repression. *Proc. Natl. Acad. Sci. USA* **81**:5017-5020.
- Forsberg, Å., and H. Wolf-Watz. 1988. The virulence protein Yop5 of *Yersinia pseudotuberculosis* is regulated at the transcriptional level by plasmid-pIB1-encoded trans-acting elements controlled by temperature and calcium. *Mol. Microbiol.* **2**:121-133.
- Gallas, D. J., and A. Schmitz. 1978. DNaseI footprinting: a simple method for the detection of protein-DNA binding specificity. *Nucleic Acids Res.* **5**:3157-3170.
- Guan, K., and J. E. Dixon. 1990. Protein tyrosine phosphatase activity of an essential virulence determinant in *Yersinia*. *Science* **249**:553-556.
- Håkansson, S., T. Bergman, J.-C. Vanooteghem, G. Cornelis, and H. Wolf-Watz. 1993. YopB and YopD constitute a novel class of *Yersinia* Yop proteins. *Infect. Immun.* **61**:71-80.
- Hoe, N. P., F. C. Minion, and J. D. Goguen. 1992. Temperature sensing in *Yersinia pestis*: regulation of *yopE* transcription by *lcrF*. *J. Bacteriol.* **174**:4275-4286.
- Inouye, S., A. Nakazawa, and T. Nakazawa. 1986. Nucleotide sequence of the regulatory gene *xylS* on the *Pseudomonas putida* TOL plasmid and identification of the protein product. *Gene* **44**:235-242.
- Lambert de Rouvroit, C., C. Sluiter, and G. R. Cornelis. 1992. Role of the transcriptional activator VirF and temperature in the expression of the pYV plasmid genes of *Yersinia enterocolitica*. *Mol. Microbiol.* **6**:379-388.
- Lee, N., C. Francklyn, and E. Hamilton. 1987. Arabinose-induced binding of AraC protein to *araI*₂ activates the *araBAD* promoter.

- Proc. Natl. Acad. Sci. USA **84**:8814–8818.
21. **Lobel, R. B., and R. Schleif.** 1990. DNA looping and unlooping by AraC protein. *Science* **250**:528–532.
 22. **Maniatis, T., E. F. Fritsch, and J. Sambrook.** 1989. Molecular cloning: a laboratory manual, 2nd ed. Cold Spring Harbor Laboratory, Cold Spring Harbor, N.Y.
 23. **Marsh, J. L., M. Erfle, and E. J. Wykes.** 1984. The pIC plasmid and phage vectors with versatile cloning sites for recombinant selection by insertional activation. *Gene* **32**:481–485.
 24. **Michiels, T., and G. Cornelis.** 1988. Nucleotide sequence and transcription analysis of *yop51* from *Yersinia enterocolitica* W22703. *Microb. Pathog.* **5**:449–459.
 25. **Michiels, T., J. C. Vanooteghem, C. Lambert de Rouvroit, B. China, M. P. Sory, A. Gustin, and G. R. Cornelis.** 1991. Analysis of *virC*, an operon involved in the secretion of Yop proteins by *Yersinia enterocolitica*. *J. Bacteriol.* **173**:4994–5009.
 26. **Miyada, C. G., A. H. Horwitz, L. G. Cass, J. Timko, and G. Wilcox.** 1980. DNA sequence of the AraC regulatory gene from *Escherichia coli* B/r. *Nucleic Acids Res.* **8**:5267–5274.
 27. **Mulder, B., T. Michiels, M. Simonet, M.-P. Sory, and G. Cornelis.** 1989. Identification of additional virulence determinants on the pYV plasmid of *Yersinia enterocolitica* W227. *Infect. Immun.* **57**:2534–2541.
 28. **Ogden, S., D. Haggerty, C. Stoner, D. Kolodrubetz, and R. Schleif.** 1980. The *Escherichia coli* L-arabinose operon: binding sites of the regulatory proteins and a mechanism of positive and negative regulation. *Proc. Natl. Acad. Sci. USA* **77**:3346–3350.
 29. **Price, S. B., K. Y. Leung, S. S. Barve, and S. C. Straley.** 1989. Molecular analysis of *lcrGVH*, the V antigen operon of *Yersinia pestis*. *J. Bacteriol.* **171**:5646–5653.
 30. **Price, S. B., and S. C. Straley.** 1989. *lcrH*, a gene necessary for virulence of *Yersinia pestis* and for the normal response of *Y. pestis* to ATP and calcium. *Infect. Immun.* **57**:1491–1498.
 31. **Reeder, T., and R. Schleif.** 1993. AraC protein can activate transcription from only one position and when pointed out in only one direction. *J. Mol. Biol.* **231**:205–218.
 32. **Rosqvist, R., A. Forsberg, M. Rimpiläinen, T. Bergman, and H. Wolf-Watz.** 1990. The cytotoxic protein YopE of *Yersinia* obstructs the primary host defence. *Mol. Microbiol.* **4**:657–667.
 33. **Sakai, T., C. Sasakawa, S. Makino, and M. Yoshikawa.** 1986. DNA sequence and product analysis of the *virF* locus responsible for Congo red binding and cell invasion in *Shigella flexneri* 2a. *Infect. Immun.* **54**:395–402.
 34. **Skrzypek, E., and S. C. Straley.** 1993. LcrG: a secreted protein involved in negative regulation of the low-calcium response in *Yersinia pestis*. *J. Bacteriol.* **175**:3520–3528.
 35. **Skurnik, M., and H. Wolf-Watz.** 1989. Analysis of the *yopA* gene encoding the Yop1 virulence determinants of *Yersinia* spp. *Mol. Microbiol.* **3**:517–529.
 36. **Straley, S. C., G. V. Plano, E. Skrzypek, P. L. Haddix, and K. A. Fields.** 1993. Regulation by Ca²⁺ in the *Yersinia* low-Ca²⁺ response. *Mol. Microbiol.* **8**:1005–1010.
 37. **Tobin, J. F., and R. F. Schleif.** 1987. Positive regulation of the *Escherichia coli* L-rhamnose operon is mediated by the products of tandemly repeated regulatory genes. *J. Mol. Biol.* **196**:789–799.
 38. **Tullius, T. D., and B. A. Dombroski.** 1986. Hydroxyl radical “footprinting”: high-resolution information about DNA-protein contacts and application to lambda repressor and Cro protein. *Proc. Natl. Acad. Sci. USA* **83**:5469–5473.
 39. **Wattiau, P., and G. R. Cornelis.** 1993. SycE, a chaperone-like protein of *Yersinia enterocolitica* involved in the secretion of YopE. *Mol. Microbiol.* **8**:123–131.
 40. **Webster, C., K. Kempell, I. Booth, and S. Busby.** 1987. Organisation of the regulatory region of the *Escherichia coli* melibiose operon. *Gene* **59**:253–263.