

# OCTAGONAL NUCLEAR PORES

JOSEPH G. GALL

From the Department of Biology, Yale University, New Haven, Connecticut

## ABSTRACT

Negative staining of isolated nuclear envelopes by phosphotungstate shows that the nuclear pores are octagonal rather than circular. Pores of the same shape and approximately the same width,  $663 \pm 5$  A, were demonstrated in the newt, *Triturus*, the frog, *Rana*, and the starfish, *Henricia*. The outer and inner diameters of the annulus associated with each pore are respectively greater and less than the width of the pore itself. For this reason surface views of the envelope, unless negatively stained, fail to show the true dimensions of the pores.

## INTRODUCTION

The first study of the nuclear envelope using the electron microscope was made by Callan and Tomlin (1950). They showed that the envelope is pierced by pores several hundred Angstroms in diameter and that raised annuli are associated with the pores. Subsequent investigations, including many studies of sectioned material, have shown that a double-layered envelope with pores and annuli is a feature common to all eukaryotic organisms (reviewed in Gall, 1964). Despite many observations two basic structural points remain to be clarified. The first of these is the actual diameter of the pore, and the second is the structural relationship between the pore and its associated annulus. Reported diameters range from about 300–1000 A. Although some scatter of values is expected for technical reasons, such a wide range would seem to imply real differences among organisms. The present study shows, however, that the pore dimensions are almost identical in three different species, and suggests that the discrepancies in the literature are due to difficulties in defining the relationship between the pore proper and its accompanying annulus (Gall, 1965).

## MATERIALS AND METHODS

Isolated nuclear envelopes have been mounted flat on a supporting film according to the technique of Callan and Tomlin (1950). They were stained or

contrasted by the phosphotungstate method of Brenner and Horne (1959). Only very large nuclei are amenable to the spreading technique and the observations have been limited so far to oocytes. The three species studied are the newt, *Triturus viridescens*, the frog, *Rana pipiens*, and the starfish, *Henricia sanguinolenta*. It is well known that the oocytes of Amphibia contain giant nuclei. The same is true of some invertebrates, including *Henricia*, whose oocyte nucleus reaches a diameter of just over 300  $\mu$ . In this starfish the female broods the large yolky eggs, which have a diameter of about 1 mm.

In each case the oocytes were removed from the animal and placed in a solution consisting of 5 parts 0.1 M KCl and 1 part 0.1 M NaCl. This mixture has been used for the study of unfixed oocyte chromosomes (techniques reviewed in Gall, 1966). Individual oocytes were broken open with forceps and the nucleus removed. After being sucked in and out of a pipette several times to remove adherent yolk, the nucleus was placed onto a 400-mesh grid covered with a collodion or Formvar film. The nucleus was flattened against the supporting film by drawing off most of the liquid with a bit of filter paper. A drop of liquid was next added to the preparation, thereby breaking open the nucleus and washing away its contents. However, the portion of envelope in contact with the film sticks tightly. One frequently obtains 10–12 grid squares covered by envelope. The envelope preparation is fixed for a few moments in 1% OsO<sub>4</sub> buffered to pH 7.2 with Veronal-acetate

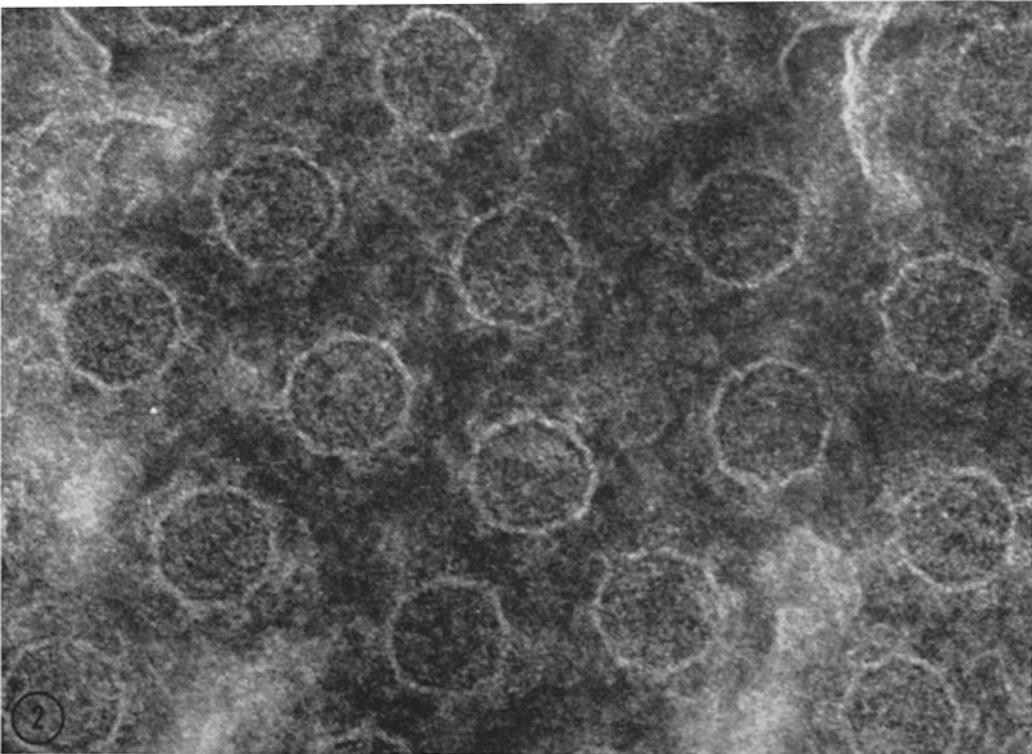
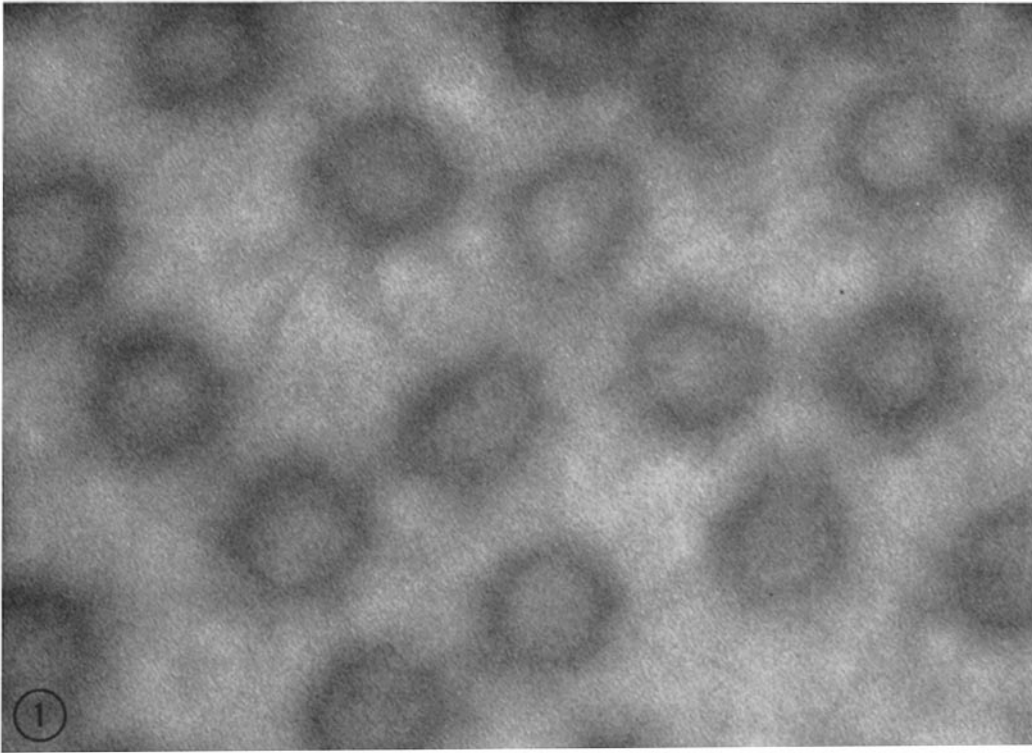

FIGURE 1 Nuclear envelope from oocyte of the newt, *Triturus*, spread on a collodion film, fixed in  $\text{OsO}_4$ , and air dried. Typical annuli with somewhat diffuse outlines are seen, but the pore perimeters are not evident.  $\times 2 \times 10^5$ .

FIGURE 2 Nuclear envelope from oocyte of the newt *Triturus*, spread on a collodion film, fixed in  $\text{OsO}_4$ , and negatively stained with phosphotungstate. Area of heavy contrast. Each pore is delimited by a thin white line, which is interpreted as the edge-on view of a unit membrane.  $\times 2 \times 10^5$ .

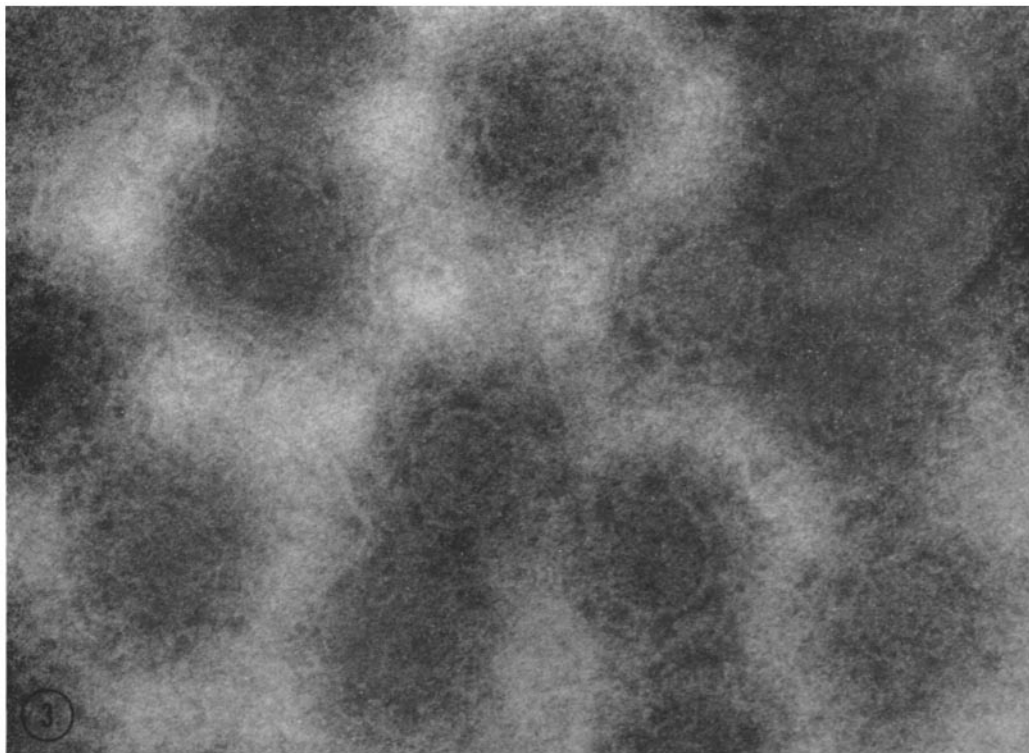

FIGURE 3 Similar to Fig. 2, but in an area of medium contrast. The phosphotungstate accumulates in puddles on the sides of the octagonal pores, although not all sides of every pore are contrasted.  $\times 2 \times 10^5$ .

(Palade, 1952). It is next washed in distilled water, and covered with a drop of 1% phosphotungstate (phosphotungstic acid brought to pH 6.6 with NaOH). Most of the liquid is drawn off, but a small amount is allowed to dry on the specimen.

#### OBSERVATIONS

##### *Octagonal Pores*

Nuclear envelopes fixed in  $\text{OsO}_4$ , washed in water, and air-dried without negative staining display a characteristic pattern of annuli on their surface (Fig. 1). The inner diameter of these annuli is rather variable, but is usually about 300–500 Å. In Callan and Tomlin's (1950) original study it was assumed that the inner diameter of the annulus corresponds to the pore diameter; this interpretation has been followed by some subsequent workers (e.g. Watson, 1959). The picture obtained after negative staining is rather different (Figs. 2, 3). Regions which clearly correspond to the pore-annulus complex are evident, but these

now consist of three distinct parts. In the center is a more or less uniformly dense area. This is surrounded by a much less dense line, approximately 60 Å thick, which defines a regular octagon. Outside of this is another dense region whose appearance depends upon the intensity of the negative stain. In some cases the area outside the octagon is rather uniformly dark (Fig. 2), but in most cases (presumably less stain) dark masses are limited to the flat sides of the octagon (Fig. 3). All eight sides of the octagon may be simultaneously contrasted, but often some of the sides are relatively free of stain. It is usually possible to discern the octagonal symmetry by counting the number of dark patches plus symmetrically disposed blank spaces. The outer boundary of a dark patch is diffuse and ill defined, but the inner boundary is often very sharp; that is, a distinct boundary exists between the thin octagonal line and the patch of stain just outside of it. One gains the impression that the white line serves to block the spreading of the stain toward the interior of the figure.

There seems to be a straightforward interpretation of this picture (Fig. 4). The phosphotungstate is able to enter the pores and hence fill them up. It also penetrates into the perinuclear space between the two nuclear membranes. In this region it can accumulate around the outside of the pore, but it cannot come into direct contact with the stain inside the pore. It is prevented from doing so because the inner and outer membranes are in direct continuity at the perimeter of each pore. Hence in surface view the only part of the pore complex which is completely free of phosphotungstate is the pore perimeter. The white line denoting the perimeter should have the same thickness as a unit membrane. The observed 60 Å thickness is in good agreement with this interpretation. That the stain should have access to the

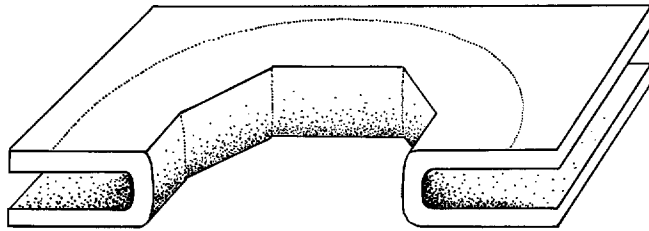

FIGURE 4 Three-dimensional view of a nuclear pore in the double-layered nuclear envelope. Outer margin of annulus dotted.

perinuclear space is easily understood, since envelopes spread by Calan and Tomlin's technique have many small tears over their surfaces. Usually the annulus is indistinguishable in negatively stained preparations. Why this should be so is not certain since other evidence discussed below indicates that the annuli are preserved by the technique. One can speculate that the loosely textured annulus is penetrated by the stain and hence displays indefinite boundaries.

That the pores possess octagonal symmetry is reasonably clear from direct inspection. In order to establish the symmetry unequivocally we have used the photographic rotation technique of Markham, Frey, and Hills (1963). In this method the micrograph is printed  $n$  times, the enlarging paper being rotated  $n/360^\circ$  between successive exposures. Structures with  $n$ -fold radial symmetry should show reinforcement of detail since background "noise" will tend to be averaged out. More importantly, the micrograph should fail to show reinforcement when tested for  $n - 1$  or  $n + 1$  symmetry. Approximately 50 rotation photographs have been made, examples of which are shown in Figs. 5-10. In each case the original micrograph

is given as well as tests for 7-, 8-, and 9-fold symmetry. In most examples reinforcement is obtained for the peripheral patches of stain when eight-fold symmetry is tested. Frequently, though not as often, the pore perimeter shows up clearly as an octagon (e.g. Fig. 6c). No unsuspected components of the pore complex have been revealed by the rotation technique. The various patterns of fine detail in the photographs are clearly attributable to the technique, since they occur in all pictures and are frequently referable to some random spot or spots on the original micrograph. Occasional reinforcement of detail occurs in the seven-fold pictures, but the pore perimeter and the outer masses of stain usually form a blurred circle in the nine-fold pictures. It is clear that reinforcement depends on both the number and spacing of details

in the original micrograph. Eight unevenly disposed masses can easily lead to reinforcement at other than eight-fold rotation. Conversely, any number of spots up to and including eight will show reinforcement after eight-fold rotation if they are spaced with eight-fold symmetry. The pores exhibit this latter situation. Some of the pores are longer than wide, and in fact possess bilateral symmetry. In such cases eight masses of stain may be easily countable but nevertheless will not reinforce. Hence the cases to be rotated were selected initially for reasonable radial symmetry.

#### *Constancy of Pore Width*

The radius of a polygon is the distance between the center and a vertex; the apothem is the perpendicular distance between the center and a side. Since the vertices are sometimes ill defined on the rotation micrographs, it is easier to measure the distance between two sides, i.e., twice the apothem. This will be referred to as the width of the octagon. Since the line defining the octagon has appreciable thickness, there are really two widths to be measured. The inner width is that of the pore proper,

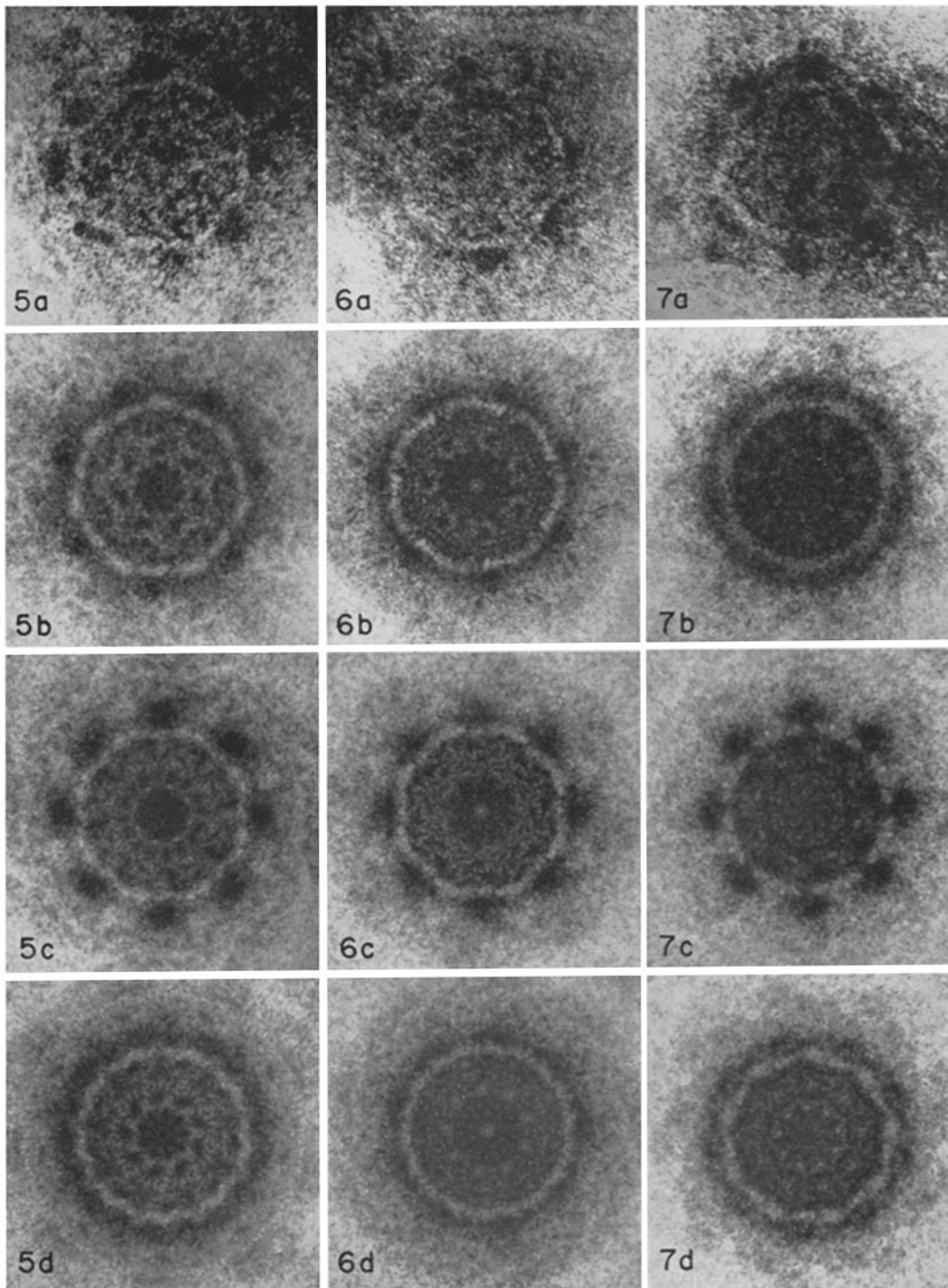

FIGURES 5-7 Tests demonstrating the 8-fold symmetry of the nuclear pores. In the top row (5 a, 6 a, 7 a) are three nuclear pores from negatively stained preparations of *Triturus* envelopes. In the lower rows the same pores are tested for 7-fold, 8-fold, and 9-fold symmetry, respectively. In 5 c and 6 c the pore perimeter shows up as an octagon; in 5 c, 6 c, and 7 c the masses of stain peripheral to the pore show reinforcement after 8-fold rotation.  $\times 3.5 \times 10^5$ .

TABLE I  
Widths of Nuclear Pores from Oocytes of *Triturus*  
From rotation micrographs

616 A	656 A
629	661
629	661
630	663
643	663
643	670
646	676
646	685
650	893
653	700
656	708
Mean $\pm$ SE = 658 $\pm$ 5 A	

the outer is the width of the pore plus the thickness of two unit membranes.

For the *Triturus* envelope a total of 22 rotation micrographs gives a mean pore width of 658  $\pm$  5 A. As shown in Table I, the range of values is narrow, all of the observations falling within about 50 A of of the mean. In order to test the generality of these results, observations were extended to the frog, *Rana pipiens*, and the starfish, *Henricia sanguinolenta*. The over-all picture in the latter two species is identical with that already seen in *Triturus* (Figs. 8-10). In fact, without prior knowledge it would be difficult to establish from which animal a given micrograph was taken. Measurements on 11 rotation micrographs of *Rana* give a mean pore width of 700  $\pm$  9 A. For *Henricia* the corresponding value from 13 micrographs is 632  $\pm$  8 A. The mean value for all observations taken together is 663  $\pm$  5 A.

The mean value for the outer width of the octagons is 781  $\pm$  6 A. The values for the three species separately are given in Table II. The difference between the outer and inner widths of the octagons is 118  $\pm$  2 A, which leads to an estimate of 59  $\pm$  1 A for the thickness of the unit membrane of which the envelope is composed. Although the standard error of the measurement is small, there may be systematic errors in the determinations. For instance, only that part of the fold which is strictly perpendicular to the direction of viewing gives a true measure of the membrane thickness. The effect of the rotation procedure is more difficult to assess and will depend on the degree of symmetry and the intensity of stain on either side of the membrane. Nevertheless, the measured value is in rea-

sonable agreement with published estimates of unit membrane thickness (Robertson, 1964).

#### Nature of the Annulus

The chief advantage of the negative staining procedure is its accentuation of the pore perimeter in surface views of the envelope. However, there remains the question why one does not see distinct annuli associated with the pores. A complete answer is not available, but it is at least possible to say that the annuli are preserved by the negative staining technique. In several preparations clusters of annuli have been found in areas *outside* the piece of flattened envelope (Fig. 11). These annuli are the appropriate general size and are distributed as they would be normally on the envelope. However, they are not associated with discernible pores. Moreover, there is little evidence of membrane material in their immediate vicinity. A tentative interpretation is that annuli can become detached when a piece of envelope touches the supporting film and then pulls away during the initial spreading procedure. Another possibility is that the two membranes of the envelope can pull apart, leaving only the outer membrane and associated annuli on the supporting film. Whichever interpretation is correct, the negative staining in these areas is light and one sees the annuli clearly. In over-all structure they appear similar to the annuli of OsO<sub>4</sub>-fixed, air-dried envelopes except that the centers of most are completely filled in. Since the annuli are darker than their surroundings, they are not being viewed by typical negative contrast. Perhaps the annuli have a relatively loose texture into which the phosphotungstate can penetrate without building up at the edges. On the envelope proper the increased density due to the annulus is overshadowed by the heavy accumulation of phosphotungstate inside and outside the pore perimeter.

The outer diameter of the detached annuli was measured on rotation micrographs and found to be about 1200 A in *Triturus*. Several annuli were also measured in *Rana* and found to have approximately the same outer diameter, but none were seen in the *Henricia* preparations. The inner diameter of the annulus varied from 0 to about 400 A. On direct inspection the annuli do not appear to be polygonal in outline. They were nevertheless tested by the rotation technique for symmetry values between 6-fold and 13-fold. No consistent reinforcement was found, and it must be concluded that annuli themselves are not octagonal after the negative staining technique.

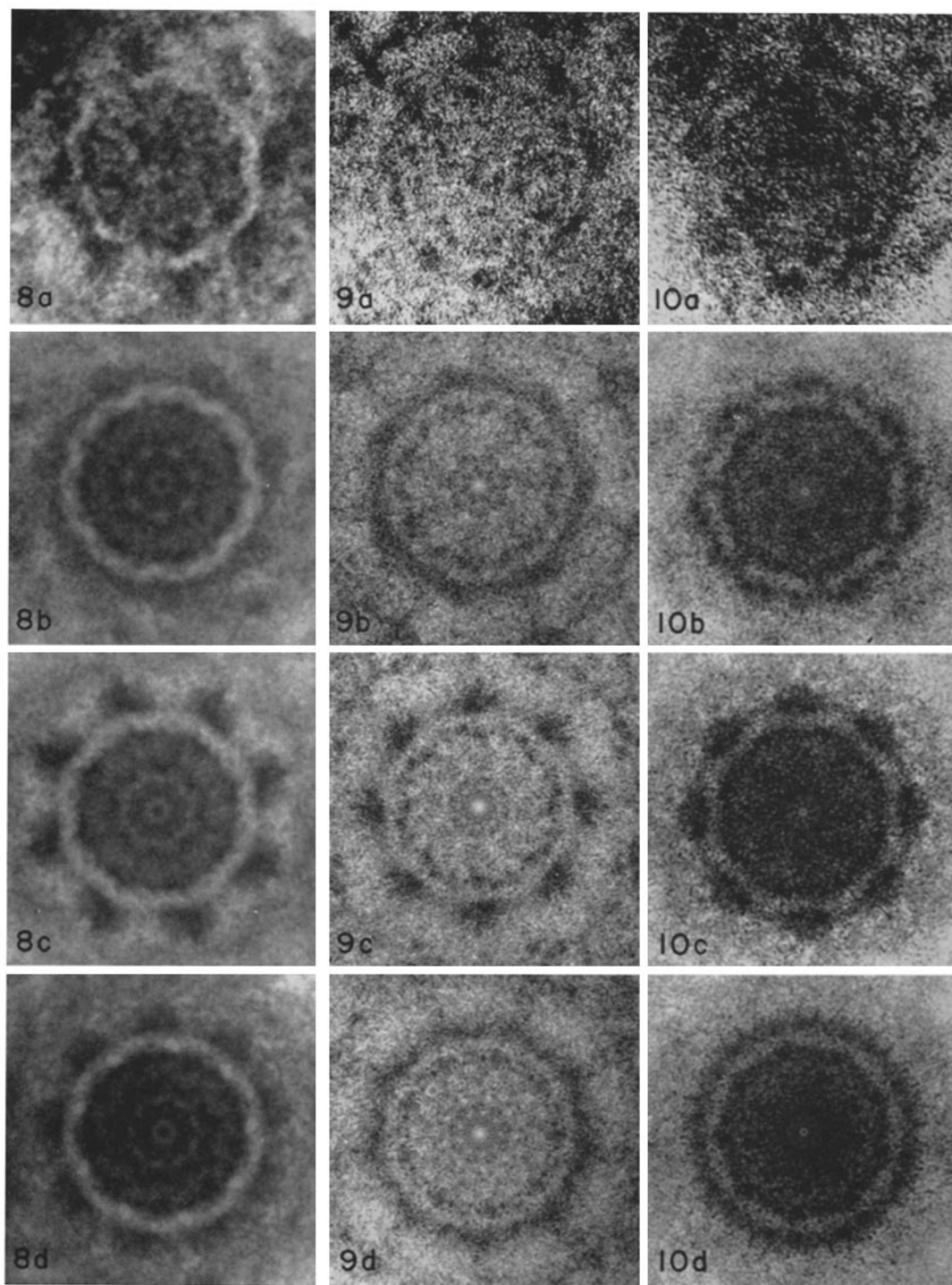

FIGURES 8-10 Further examples of the rotation test, establishing octagonal symmetry of the nuclear pores. The top row consists of micrographs of pores from the newt, *Triturus* (8 a), the starfish, *Henricia* (9 a), and the frog, *Rana* (10 a). In the lower rows the same micrographs are tested for 7-fold, 8-fold, and 9-fold symmetry, respectively. Note the essential identity of dimensions in the three species.  $\times 3.5 \times 10^5$ .



TABLE II  
*Nuclear Pore Dimensions from Oocytes of Three Species*  
 Measurements in Angstrom units (mean  $\pm$  SE)

Species	Inner width	Outer width	Membrane	n
<i>Triturus viridescens</i>	658 $\pm$ 5	775 $\pm$ 5	59 $\pm$ 2	22
<i>Rana pipiens</i>	700 $\pm$ 9	825 $\pm$ 10	63 $\pm$ 2	13
<i>Henricia sanguinolenta</i>	632 $\pm$ 8	745 $\pm$ 8	56 $\pm$ 2	11
All measurements	663 $\pm$ 5	781 $\pm$ 6	59 $\pm$ 1	46

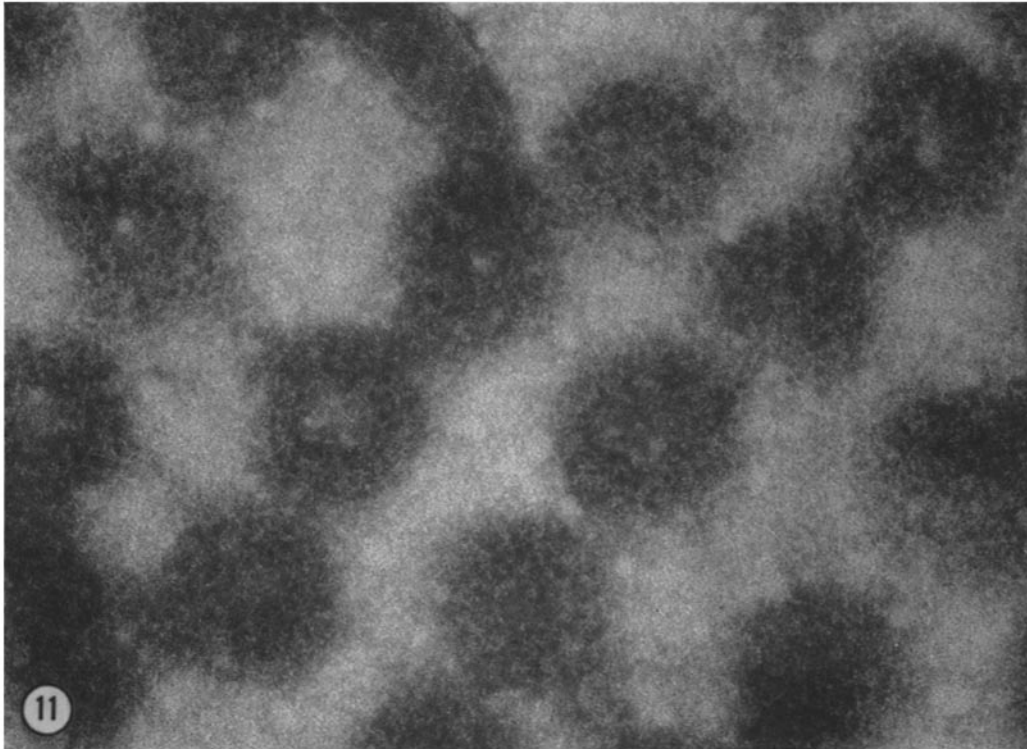

FIGURE 11 Free annuli from a nuclear envelope of the newt, *Triturus*. During specimen preparation the envelope may touch the supporting film and later become detached. When this happens, annuli or parts of them appear to remain behind on the film. Negatively stained with phosphotungstate after OsO<sub>4</sub> fixation.  $\times 2 \times 10^5$ .

#### DISCUSSION

The negative staining technique demonstrates the octagonal shape of the nuclear pores and permits a more accurate determination of the pore width than heretofore possible (Fig. 12). The octagonal shape comes as a surprise, since earlier observers have invariably described the pores as circular. On the other hand it has been suggested that the *annuli* are composed of 8-10 lumps or granules

(Gall, 1954), and Wischnitzer (1958) postulated that the annulus consists of eight microtubules arranged inside a circular pore. Although negative staining has provided no evidence for microtubules in the pore complex, it seems probable that the material of the annulus may at times conform to the outline of the pore proper. Wischnitzer was correct, therefore, in assigning octagonal symmetry to the pore complex.



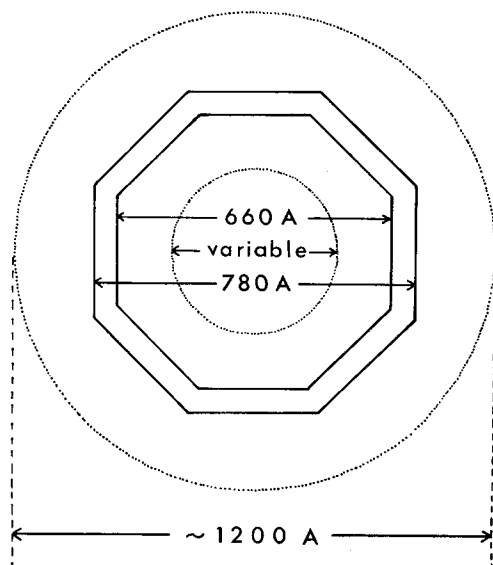

FIGURE 12 Dimensions of a nuclear pore and its associated annulus. The inner and outer margins of the annulus are represented by dotted lines. The pore proper is shown in solid lines.

The demonstration of a similar pore size in three different species, including two amphibians and a starfish, suggests that the pore structure may be the same wherever found. It has been known for several years that the nuclear envelopes of all eukaryotic cells which have been examined possess similar pores and annuli, but the reported diameters of the pores have varied from about 300 to 1000 Å. In light of such variability it has been

#### BIBLIOGRAPHY

- BRENNER, S., and R. W. HORNE. 1959. A negative staining method for high resolution microscopy of viruses. *Biochim. Biophys. Acta.* 34:103.
- CALLAN, H. G., and S. G. TOMLIN. 1950. Experimental studies on amphibian oocyte nuclei. I. Investigation of the structure of the nuclear membrane by means of the electron microscope. *Proc. Roy. Soc. (London), Ser. B.* 137:367.
- GALL, JOSEPH G. 1954. Observations on the nuclear membrane with the electron microscope. *Exptl. Cell Res.* 7:197.
- GALL, JOSEPH G. 1964. Electron microscopy of the nuclear envelope. *Protoplasmatologia.* 5:4.
- GALL, JOSEPH G. 1965. An octagonal pattern in the nuclear envelope. *J. Cell Biol.* 27:121A.
- GALL, JOSEPH G. 1966. Techniques for the study of lampbrush chromosomes. In *Methods in Cell Physiol.* D. Prescott, editor. Academic Press Inc., N.Y. 2:37.
- MARKHAM, R., S. FREY, and G. HILLS. 1963. Methods for the enhancement of image detail and accentuation of structure in electron microscopy. *Virology.* 20:88.
- PALADE, G. 1952. A study of fixation for electron microscopy. *J. Exptl. Med.* 95:285.
- ROBERTSON, J. D. 1964. Unit membranes: a review with recent new studies of experimental alterations and a new subunit structure in synaptic membranes. *Cellular Membranes in Development. Sym. Soc. Study Develop. Growth* 22 (1963) 1.
- WATSON, M. L. 1959. Further observations on the nuclear envelope of the animal cell. *J. Biophys. Biochem. Cytol.* 6:147.
- WISCHNITZER, S. 1958. An electron microscope study of the nuclear envelope of amphibian oocytes. *J. Ultrastruct. Research.* 1:201.

difficult to postulate an underlying structural similarity. It now seems probable that the reported variability stems largely from difficulty in defining just what is the pore perimeter. In transverse sections of the envelope the apparent pore diameter will be influenced by the section thickness (Watson, 1959), only very thin sections through the exact center of a pore giving a reliable value. When the envelope is cut tangential to its surface, the annuli will frequently obscure the pore margins, as they do in air-dried isolated envelopes. As we have seen, the inner diameter of the annulus is not a reliable estimate of pore width, although it is probably the value most commonly reported. If the geometry of the pore complex is indeed constant throughout all organisms, then this geometry is probably imposed by molecular constraints common to lipoprotein membranes.

The relationship between pore and annulus remains a perplexing question. The present study has shown that the annuli, or parts of them at least, can become physically detached from the envelope. Under such conditions they do not display an octagonal symmetry as the pores do, nor is much fine structure revealed by negative staining. It may be that the spreading technique distorts the annuli, since in sections they appear quite loose-textured. Other techniques will have to be found before an accurate picture of the annulus is obtained.

This investigation was supported by Public Health Service Research Grant GM 12427 from the National Institute of General Medical Sciences.

Received for publication 21 July 1966.