

LASER-INDUCED SPREADING ARREST OF *MYTILUS* GILL CILIA

TATSUO MOTOKAWA and PETER SATIR

From the Zoological Institute, Faculty of Science, University of Tokyo, Tokyo 113, Japan. Dr. Satir's present address is the Department of Physiology-Anatomy, University of California, Berkeley, California 94720.

ABSTRACT

Using a "slit camera" recording technique, we have examined the effects of local laser irradiation of cilia of the gill epithelium of *Mytilus edulis*. The laser produces a lesion which interrupts epithelial integrity. In artificial sea water that contains high K^+ or is effectively Ca^{++} free, metachronism of the lateral cilia continues to either side of the lesion with only minor perturbations in frequency synchronization and wave velocity, such as would be expected if metachronal wave coordination is mechanical. However, in normal sea water and other appropriate ionic conditions (i.e., where Ca^{++} concentration is elevated), in addition to local damage, the laser induces distinct arrest responses of the lateral cilia. Arrest is not mechanically coordinated, since cilia stop in sequence depending on stroke position as well as distance from the lesion. The velocity of arrest under standard conditions is about 3 mm/s, several orders of magnitude faster than spreading velocities associated with diffusion of materials from the injured region. Two responses can be distinguished on the basis of the kinetics of recovery of the arrested regions. These are (a) a nondecremental response that resembles spontaneous ciliary stoppage in the gill, and (b) a decremental response, where arrest nearer the stimulus point is much longer lasting. The slower recovery is often periodic, with a step size approximating lateral cell length. Arrest responses with altered kinetics also occur in latero-frontal cilia. The responses of *Mytilus* lateral cilia resemble the spreading ciliary arrest seen in *Elliptio* and arrest induced by electrical and other stimuli, and the decremental response may depend upon electrotonic spread of potential change produced at the stimulus site. If this were coupled to transient changes in Ca^{++} permeability of the cell membrane, a local rise in Ca^{++} concentration might inhibit ciliary beat at a sensitive point in the stroke cycle to produce the observed arrest.

The lateral cilia of the gill epithelia of lamelli-branch molluscs usually beat with well-defined metachronism (Gray, 1930; Satir, 1963; Aiello and Sleigh, 1972). The metachronal waves, wavelength 10 μ m, are created by rows of cilia that beat out of phase one with the next. The waves travel at speeds of several hundred micrometers per second in a direction fixed by the ciliary beat. The mechanism

of coordination responsible for metachronism is thought to be primarily mechanical and not electrical (neuroidal), although most of the evidence for this comes from protozoa where the waves obviously do not cross cell boundaries (Eckert and Naitoh, 1970; Macheiner, 1972).

For many years it has been known that under certain circumstances the lateral cilia stop beating

and come to rest in a unique position. Stoppage can occur spontaneously (Lucas, 1932; Tsuchiya and Takahashi, 1972), or it can be elicited in response to electrical (Segerdahl, 1922; Murakami, 1968), nervous (Takahashi and Murakami, 1968), or chemical (Takahashi, 1971) stimulation. Stimulation can be applied in a highly localized manner to a few epithelial cells. For example, one of us¹ has shown that local mechanical stimulation of the cilia with a glass stylus produces a characteristic spreading stoppage in *Mytilus* lateral cilia, and one of us (Satir et al., 1971, 1972) has shown that, in *Elliptio* gill, local laser irradiation of the epithelium also produces spreading arrest.

The mechanism of arrest has not been studied until very recently, but even in early reports (e.g., Lucas, 1932) it was noted that the stoppage has characteristics of "neuroid" transmission. In simplest terms, this would mean that the coordination event responsible for stoppage is ionically controlled via the epithelial cell cytoplasm and that this event can cross epithelial cell boundaries (cf. Mackie, 1970 for definition and review). Our recent studies tend to support this hypothesis. Nevertheless, the good quantitative data that are necessary to define the arrest phenomenon in a precise manner are extremely limited, while the phenomenon itself, with its general implications for epithelial communication, seems worthy of careful study.

In this report, we have studied the production of spreading ciliary arrest in lateral cilia of *Mytilus edulis* epithelium by local laser irradiation, using the "slit camera" recording technique of Takahashi and Murakami (1968). In previous studies of laser-produced stoppage (Satir et al., 1972), only direct high speed cinematography was employed, so that quantitation of arrest parameters, such as velocity of spread, was cumbersome. The slit camera method improves the precision of calculation of event kinetics considerably. In *Mytilus*, we are able to operate with a single gill filament, and to compare the results of laser stimulation directly with previous studies with mechanical stimulation in the same system.¹ Moreover, *Mytilus* is a seawater organism, which provides a reproducible standard for the normal ionic composition of the medium, and the morphology of the lateral cilia is well-known (Aiello and Sleight, 1972). With this system, we are able to define the time-course of

¹ Motokawa, T., and K. Takahashi. Manuscript in preparation.

laser-induced spreading arrest, to indicate some features of ionic control of this phenomenon, and to examine differences in the propagation of the stoppage and of the metachronal wave.

METHODS

M. edulis was obtained from the Misaki Marine Biological Station of the University of Tokyo at regular intervals. The mussels were maintained in an aquarium at 19°C in circulating filtered natural seawater for several weeks.

For experimentation, the posterior adductor muscle was severed, mussels were opened, and the ctenidia were carefully excised into seawater. Generally, the gill nearest the right side mantle epithelium was chosen for further dissection and stripped by cutting the fibrous connections between lamellae, so as to separate descending from ascending halves. Single gill filaments were obtained from the descending lamella by careful teasing in the following manner: A piece of the lamella was placed in a special chamber, shown in Fig. 1, modified from a design of Dr. S. A. Baba of the Zoological Institute. The chamber was filled with the desired solution. First, small groups of ca. three filaments were pulled away from the remaining mass. The filaments were held together at this

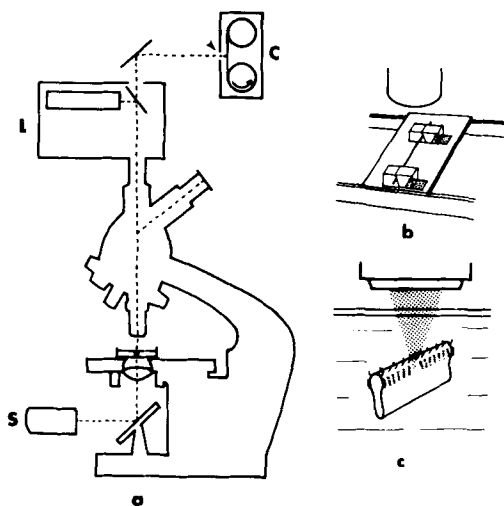

FIGURE 1 Experimental setup for laser irradiation of *Mytilus* gill tissue. (a) Schematic showing laser (L) mounted on microscope column. Dashed lines indicate optical paths. Light from substage lamp (S) is passed through specimen and then to eyepiece or slit camera (C) by appropriately placed prisms. Arrowhead indicates position of slit. Laser light passes down column to irradiate specimen. (b) Diagram showing mounted gill filament, held in place by chamber platforms. (c) Detail indicating filament orientation to laser beam (stipples). The beam is focused on the lateral cilia. Above these lie the laterofrontal cirri.

point only by the ciliary pads that form friction-mesh fasteners. With two fine forceps, adjacent filaments in the group were then grasped and pulled in opposite directions. The fasteners separated under this applied force. The operation was repeated until a single, intact, relatively unperturbed filament was obtained from the center of the group. With a minimum of handling, the filament was mounted and held rigidly on either end between two glass pieces that form the chamber platforms. The

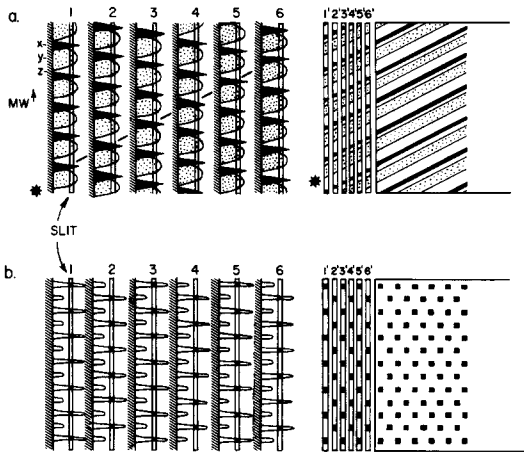

FIGURE 2 Interpretation of slit camera image of ciliary beat. (a) Lateral cilia show h-shaped metachronal wave. Image of metachronal wave is positioned on slit so that extended cilia are intercepted. In exposure 1, this produces thin dark line (x), corresponding to the most extended cilia; a small white zone, corresponding to the area between these cilia and the bulge of the h; a large grey zone corresponding to the bulge of the h, and to early and mid-recovery stroke positions of the cilia (y); and, finally, a large white zone, corresponding to the most flattened cilia in late recovery and early effective stroke positions (z) (see Gray, 1930). In exposure 2, these zones are displaced because of movement of the living metachronal wave in direction of arrow; displacement continues in exposures 3, 4, 5, 6. The film, moving at set speeds behind the slit, allows such images as 1', 2', 3', etc. to run together to form smooth sloping lines. One wavelength is marked with an asterisk to show the correspondence more clearly. Compare Fig. 3 a. If the slit is moved nearer the cell, the small white zone between the two grey zones vanishes. See text and Takahashi and Murakami (1968) for further explanation. (b) Latero-frontal cirri on one cell function as a unit. Slit placed on image of these cirri intercepts those that are extended to produce dark patch. Cirri bend rhythmically so that a series of squares appears on the moving film. Horizontal row indicates beat of single cirrus; vertical column indicates synchrony of beat; displacement of squares in vertical direction indicates asynchrony of beat in adjacent cirri.

distance between cover glass and filament indirectly influences the extent of the laser lesion and the ease of recording and must be adjusted empirically. The chamber fits as a slide on the stage of a compound microscope (Tiyoda R1) upon which the biolaser (Control Data Hadron/TRG Model 513, Hadron Inc., Korad Div., Santa Monica, Calif.) was mounted.

The biolaser emitted a short pulse of 694 nm red laser light when triggered. The laser beam was reduced by the optics of the microscope to a desired size and focused on the lateral cilia of the mounted gill filament. All solutions were made up with a blue dye (Brilliant Blue F.C.F.) 0.1 mg dye/100 ml solution (Goldstein, 1969). The dye absorbed the focused radiation to produce a local region of high temperature, which damaged the tissue (Goldstein, 1972; Satir et al., 1972). In our experiments, the laser lesion was 6–18 μm wide.

The responses of the cilia were recorded by a slit camera (Takahashi and Murakami, 1968). The image of the microscope field was projected through a slit (width: 0.1 mm) onto a film which was running at a constant speed. Lateral cilia in a metachronal wave are actually beating perpendicular to the metachronal wave direction such that the wave form usually projected on the slit represents a profile view of the cluster of cilia in which the ciliary stroke is displayed running antiparallel to the direction of the wave. The effective stroke of the laterofrontal cirri is also normal to the wave direction, but in these cilia metachronism is best defined by the slit record itself. An explanation of the recording is given in Fig. 2.

Experiments were performed both in natural seawater from Misaki and in artificial seawater. The composition of control artificial seawater of normal ionic composition was as follows (mM): NaCl, 433; KCl, 10.0; CaCl₂, 10.1; MgCl₂, 52.5; NaHCO₃, 2.5 (pH 8.1). When changed concentrations of cations were to be employed in experimental artificial seawaters, the concentration of NaCl was also modified to compensate for osmotic pressure change. In the case of high concentration of Ca⁺⁺, the solution was buffered by Tris-HCl. As the lateral cilia on the isolated gill filament usually cease to beat in seawater, we added 5-hydroxytryptamine (5-HT) to activate the beating (final concentration of 10⁻⁷ M).

All experiments were performed at room temperature (18.6–24.5°C).

RESULTS

Residual Effects of Laser Irradiation on Metachronal Activity

In the slit camera records shown here, normal metachronal activity of the lateral cilia appears as a series of oblique lines of uniform width and repeating substructure (Fig. 2, 3 a). The exact substructure of the lines depends on the precise

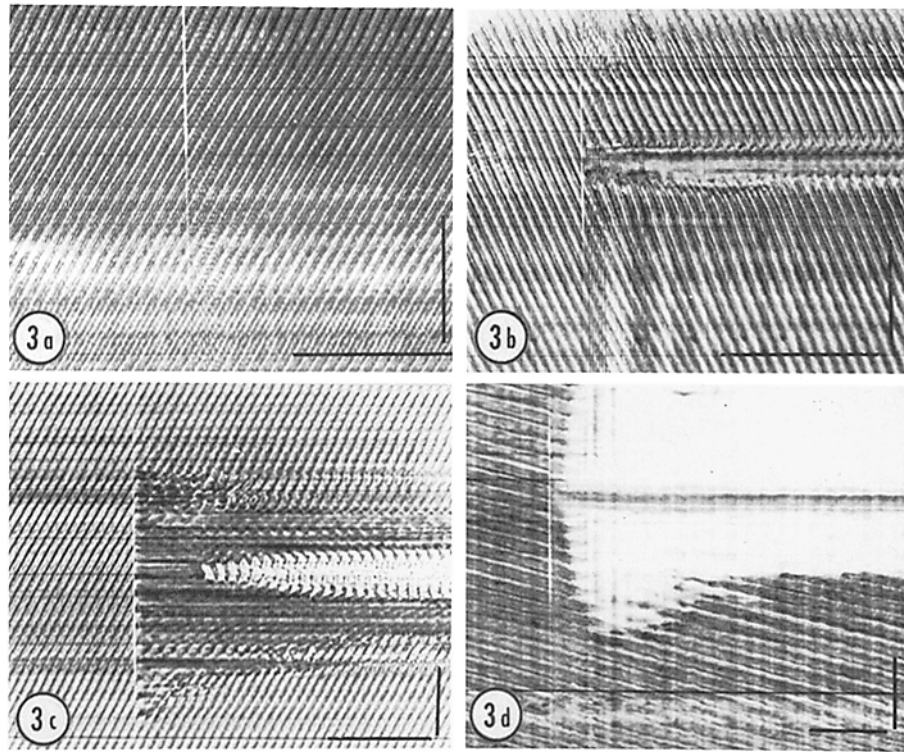

FIGURE 5 Slit camera records of lateral cilia. Ca^{++} series. All solutions contain 10^{-7} M 5-HT. Vertical scales: $50 \mu\text{m}$. Horizontal scales: (a-c) 0.5 s; (d) 50 ms. White line indicates time of laser firing. (a) Laser incorrectly focused. No interruption of metachronal wave pattern. Gill in artificial seawater containing 100 mM Ca^{++} . (b) Gill in artificial seawater containing 100 mM KCl. Laser damage limited to small central lesion. Note slope changes and phase shift of pattern to downward side of lesion. (c, d) Gill in artificial seawater of normal ionic composition. Note spreading ciliary arrest. See text for details.

placement of the slit with regard to the projection of metachronal wave form. White (overexposed) areas indicate those portions of the wave where the cilia did not block the slit, while black (underexposed) areas indicate those portions where cilia block the slit. A single record shows only a portion of one gill filament. In healthy preparations with normal ionic composition, such portions were reasonably well synchronized with respect to beat frequency, metachronal wave velocity, and other wave parameters. This accounts for the uniformity of the line pattern. The slopes of the lines measure the wave velocity, which averaged $240 \mu\text{m/s}$ in the present experiments, and the vertical periods measure the metachronal wavelengths (ca. $10 \mu\text{m}$). Since waves move oppositely on the two sides of a single gill filament, patterns taken from opposite sides of a filament slant in opposite directions (Fig. 3 a vs. 3 b). A horizontal transsection of the pattern indicates the behavior of a single cilium or

group of cilia with time and also measures beat period.

At the instant of laser firing, the film at the slit was overexposed for some distance to either side of the target area. The result is a white line on the record, which marks the firing time, and also indicates the approximate slit width. Only the central few micrometers of the line are the target area itself.

Laser irradiation of the lateral cells produced a lesion which appears in the records as a break in the continuously progressing line pattern (Fig. 3 b). After several seconds of recording, we observed the target area directly under the microscope and noted permanent damage. Normally, the lesion was visible as an exploded area with a small cluster of nonbeating cilia in an otherwise unperturbed field. In the records, breaks in the line pattern corresponding to such regions of permanent damage continued without alteration for the duration

of the recording. Focusing of the laser was critical, and when the laser was slightly out of focus, it did not make a lesion (Fig. 3 a). When no lesion was made, the irradiation failed to induce a discernible change in the line pattern, and hence in the beating of the lateral cilia in every solution tried. With certain solutions including artificial seawater containing high potassium (100 mM), there was no ciliary arrest beyond the permanently damaged target area after irradiation (Fig. 3 b). In such cases, the metachronal wave progression continued up to the lesion, and picked up again immediately beyond the lesion. Careful examination revealed that some change in wave parameters frequently occurred to both sides of the lesion; usually velocity decreased to the uphill side of the lesion (relative to wave progression) and increased to the downhill side. For example, in Fig. 3 b, the velocity of the waves past the lesion has increased immediately after irradiation, as evidenced by the abruptly steeper slope of the lines on the record, so that frequency synchronization of the tissue is lost. Even where frequency synchronization persisted, as it often did, the phase relations between cilia at opposite sides of the lesion were often altered. In such instances, when we extrapolated the oblique lines from one side of the lesion to the other side, the lines, although parallel, did not coincide.

Ciliary Arrest in Normal Seawater

When a lesion was made in the lateral cells on gill filaments bathed in natural or artificial seawater with normal ionic composition or other appropriate solutions, an additional perturbation in the pattern was seen. The irradiation induced a sudden local spreading arrest of ciliary beat around the stimulated region (Fig. 3 c, d).

The final extent of the interruption of the line pattern was at least three times the extent of the target area as measured directly and in records such as Fig. 3 b. Typically, after irradiation the interruption grew for some time, then waned, and then finally returned to the size of the target area. In some records (Fig. 3 d, for example), contrast was maintained between the permanently damaged central area (about 20 μm long) and the wider zone of temporarily stopped cilia (over 70 μm to either side of the lesion at its maximum extent in Fig. 3 d). Since a *Mytilus* lateral cell is approximately 10 μm long, in this case, the cilia of at least six undamaged cells to either side of the target area were arrested by the stimulus. The average value for the maximum extent of the arrest in normal seawater measured from the center of the lesion to one edge of the arrested zone is about 58 μm (Table I).

TABLE I
Effect of Calcium Concentration on Parameters of Spreading Arrest

Ca ⁺⁺ Concn	Extent	Duration		Velocity of spread			Significance <i>P</i> = 0.05	
		Fast phase	Slow phase	Average	With MW*	Against MW	Against MW vs. with MW	Average vs. 10 mM
<i>mM</i>	μm	<i>msec</i>		<i>mm/sec</i>				
0	No arrest	—	—	—				
1	>130‡	175 ± 99 (9)§ 196 ± 58 (7)	>1000	2.90 ± 0.76 (9)	2.36 ± 0.81 (3)	3.03 ± 0.92 (3)	No	No
10	57.8 ± 13.8 (30)	56.6 ± 14.5 (6)	300–2600	3.05 ± 1.16 (13)	2.68 ± 0.49 (5)	2.63 ± 0.39 (5)	No	—
82.4	>130‡	203 ± 33 (6)	—	9.88 ± 2.53 (9)	9.49 ± 1.73 (4)	11.07 ± 3.33 (4)	No	Yes

Values are means ± SD. Numbers of measurements given in parentheses. Extent is the distance between the center of the lesion and the edge of the arrested zone. Maximum measurable extent is 130 μm . Duration is measured for cilia at the edge of the arrested zone or the edge of the record where arrest exceeds 130 μm for the fast phase, and immediately adjacent to the damaged center of the lesion for the slow phase.

* MW, metachronal wave direction.

‡ Fast phase.

§ Laser-induced.

|| Spontaneous.

While metachronal wave progression always proceeded in one defined direction on a given record, records made with faster film speed showed that the ciliary arrest spread symmetrically out from the lesion to either side of the target area. No significant difference could be detected between the spread in opposite directions in either extent ($57.5 \pm 19.9 \mu\text{m}$ with the metachronal wave vs. $58.2 \pm 19.7 \mu\text{m}$ against the wave, 15 measurements in either direction, in normal seawater, $P > 0.05$) or velocity (Table I). The velocity of the spread in normal seawater, ca. 3 mm/s (Tables I, II), was more than 10 times that of metachronal wave propagation. From wavelength to wavelength, the spread was almost linear, indicating a constant velocity of stimulus propagation.

Fig. 3 *d* shows that cilia in the same metachronal wavelength did not all stop simultaneously, but stopped in a characteristic order which was the same in every arrested wavelength, irrespective of whether the direction of spread of the arrest was with or against the direction of wave propagation. Since wavelength and cell length are about the same in *Mytilus*, we conclude that all cilia on a single lateral cell did not stop simultaneously after irradiation. The characteristic sequence of arrest is shown clearly for several wavelengths in Fig. 3 *d* and in more detail in Fig. 4. Arrest begins in wavelengths farther from the lesion before cilia in wavelengths nearer the lesion have been stopped completely. The stimulus propagates much faster than the majority of cilia within a wavelength respond. In Figs. 3 *d* and 4, at one edge of the zone that forms the major portion of each wavelength, the slope of the line pattern is unchanged for some time, indicating that normal beat continues. At the opposite edge, the slope abruptly falls to zero

TABLE II
Velocity of Spreading Phenomena in Gill Ciliary System

Phenomenon	Ca ⁺⁺ concn	Stimulation	Specimen	Cilia	Speed
	<i>mM</i>				<i>μm/s</i>
Stoppage	10	Nerve	M	L	$> 5 \times 10^4$
Stoppage	82.4	Laser	M	L	1×10^4
Stoppage	10	Laser	M	L	3×10^3
Stoppage	1	Laser	M	L	3×10^3
Stoppage	Trace	Laser	E	L	5×10^2
Metachronal wave	10	—	M	L	2×10^2
Activation	10	Laser	M	L	5
Stoppage	10-100	Laser	M	LF	5

Specimen: M is *Mytilus* and E *Elliptio*. Cilia: L is lateral cilia and LF laterofrontal cilia.

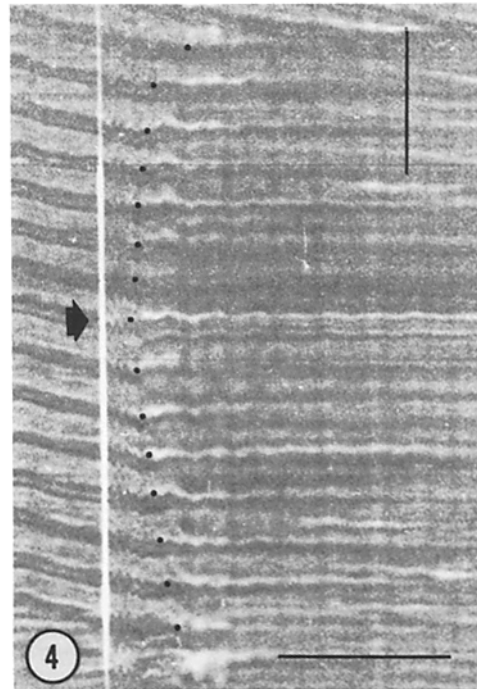

FIGURE 4 Slit camera record of mode of spread of arrest. Gill in artificial seawater, normal ionic composition with 10^{-7} M 5-HT. Arrowhead indicates center of lesion from which arrest spreads uniformly to both sides. Dots indicate points where slope of pattern first becomes zero in each successive metachronal wavelength. See text for details. Waves appear with negative contrast. Vertical scale: 25 μm . Horizontal scale: 25 ms. White line indicates time of laser firing.

(points marked on Fig. 4) so that the contrasting minor portion of each wavelength (white in Fig. 3 *d*, dark in Fig. 4) begins to increase in width. The result is a wedge that represents fewer and fewer beating cilia within the wavelength. During this time, where the arrest spreads with the metachronal wave, the unaltered edge of each wavelength is nearer to the lesion than the altered edge (Fig. 4, points below arrowhead). Where the arrest moves against the wave, the altered edge is nearer to the lesion (Fig. 4, points above arrowhead). Therefore, the time-course of arrest for a cilium depends upon the stroke position in which the cilium finds itself when stimulated, as well as the time at which the stimulus arrives.

In Fig. 4, the indicated black dots correspond to cilia first affected by the stimulus. According to the reconstruction of the slit image seen in Fig. 2, these cilia would be near the early recovery stroke. The beat is displayed in the direction antiparallel

to that of the metachronal wave (Gray, 1930; Satir, 1963) such that immediately below each black dot lie cilia in effective stroke positions and the unaltered edge of the major zone of each wavelength corresponds to cilia in late recovery stroke positions.

THE RECOVERY: Recovery from the arrest started from the margins of the affected area and usually proceeded centrally (Fig. 3 *d*, 5 *c*). Thus, the duration of the arrest of each cilium depended on the distance along the gill filament between the cilium and the lesion; the larger the distance, the shorter the duration. The relation between the duration and the distance was not linear and occasionally showed distinct periodicity. It normally took up to 3 s for all the cilia in seawater to recover except in the damaged target area, but in some cases the stoppage lasted more than 10 s.

Occasionally, the recovery occurred in two distinct phases. During the initial phase, as cilia at the margin of the arrested zone recovered, the velocity of the recovery was much faster than during the second phase where cilia closer to the lesion recovered. In Fig. 3 *d*, for example, at the edges of the stopped region the arrest duration was 57 ms, and the initial recovery velocity was 1 mm/s. The velocity slowed greatly, to 34 $\mu\text{m/s}$, 40 μm distant from the lesion. In cases where only one recovery rate was observed, that rate was identical to the slow portion of the two-phase recovery.

Upon recovery, it took several beats before the cilia reestablished normal metachronal coordination. Cilia that were arrested and recovered reestablished phase relations with adjacent cilia that had never stopped so that the join was usually smooth. Alterations in wave parameters which developed after arrest and recovery were no different in kind from those seen in laser-irradiated tissue where no arrest occurred.

Occasionally, cilia recovered simultaneously from the margins of the stopped area and from the center of the lesion (Fig. 3 *c*). In these cases, the recovery spread from the margins to center in the ordinary manner, but in addition, the cilia immediately adjacent to the lesion began beating again 0.1–1 s after the irradiation, and the recovery spread toward the margins of the stopped area with the speed of 5 $\mu\text{m/s}$. Although the frequency of beat of cilia recovering from the center was the same as that before irradiation, the beat form and the coordination were different. Beating was almost synchronous, as indicated by the almost

vertical slope of the lines on the record. After all the cilia had recovered, the region of synchronous beating gradually became narrower, and after about 10 s, all the cilia showed normal beat and metachronism.

Effects of Ca^{++}

Since Ca^{++} appears to play an important role in the control of beat in protozoa and perhaps elsewhere, we investigated the effects of raising and lowering Ca^{++} in the gill system. These effects are summarized in Table I and Fig. 5.

Ca^{++} -FREE SOLUTIONS: In Ca^{++} -free artificial seawater, the gill preparation was unstable. After a few minutes, the cilia did not beat well, and metachronism often became somewhat irregular. Nevertheless, occasional regions with some metachronism were found (Fig. 5 *a*). Laser irradiation never induced the propagated ciliary stoppage in such regions although lesions were visible.

LOW Ca^{++} : In artificial seawater containing as little as 1 mM Ca^{++} , laser irradiation induced spreading ciliary arrest. The velocity of spread was approximately the same as that in normal seawater (Table I), but the extent of spread increased beyond the limits of our records ($>130 \mu\text{m}$ to either side of the lesion). Moreover, the mode of recovery usually was biphasic (Fig. 5 *b*). Both phases resembled the biphasic recovery sometimes seen in normal seawater (Fig. 3 *d*), except that the fast initial phase affected a much greater number of cilia. As in normal seawater, the slower recovery phase was confined to the cilia around the irradiated region ($<40 \mu\text{m}$ from the lesion), while recovery velocity of the cilia on the region more distant from the lesion was over 25 times faster.

In low Ca^{++} , the lateral cilia show spontaneous arrest (Tsuchiya and Takahashi, 1972; footnote 1) that can occur over wide ($>200 \mu\text{m}$) areas of the gill filament. It is not always clear where the point of origin of the arrest is. In our records, the duration of spontaneous arrest was approximately the same for all arrested cilia. At high recording rates, the spontaneous arrest appeared as a nearly rectangular interruption of the background line pattern. This corresponded to the wing-shaped initial portion of the biphasic response of the arrested cilia. Figure 6 *a* compares a spontaneously occurring arrest with a laser-induced stoppage produced several seconds later. The major difference in response is the slow recovery phase seen in the latter record. The duration of the

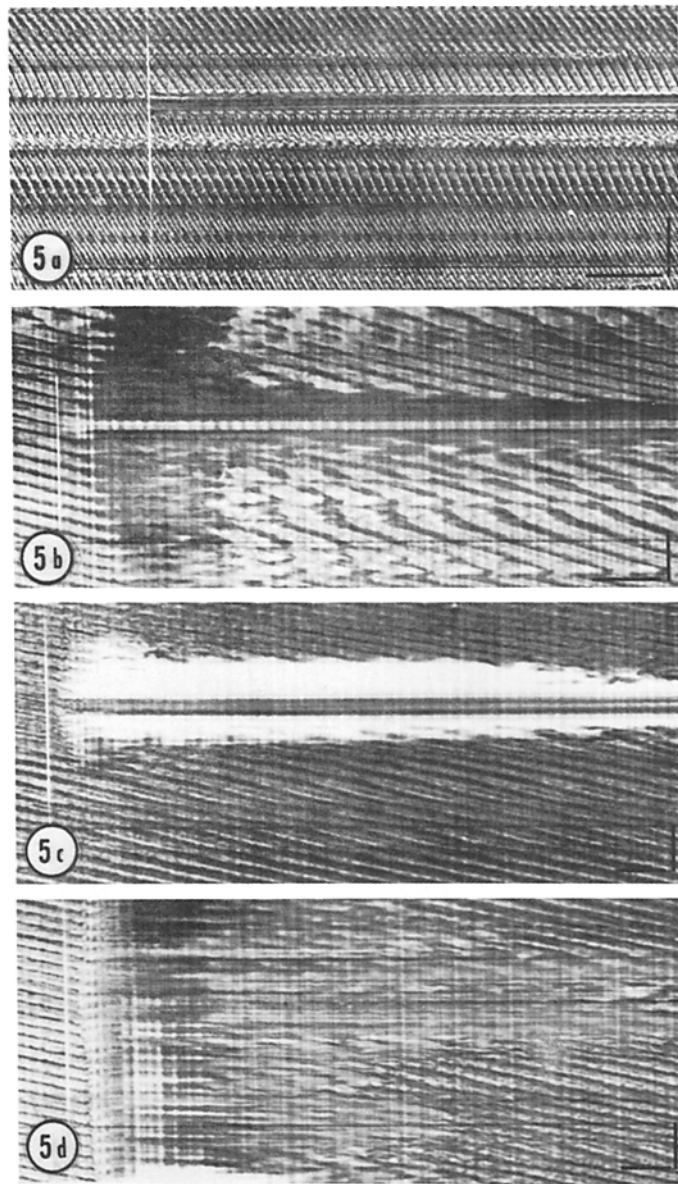

FIGURE 5 Slit camera records of lateral cilia. Ca^{++} series. All solutions contain 10^{-7} M 5-HT. Vertical scale: $50 \mu\text{m}$. Horizontal scales: (a) 0.5 s; (b-d) 50 ms. White line indicates time of laser firing. (a) Ca^{++} -free seawater. (b) 1mM Ca^{++} . Note biphasic response. (c) Control in normal seawater, 10mM Ca^{++} . (d) 82.4 mM Ca^{++} .

spontaneous arrest is identical to that in the initial fast recovery phase in the laser-induced arrest (Table I).

During the slow phase, recovery occurred by groups of cilia. Apparently all cilia in one area recovered quickly, while spread from area to area was slower. Distinct periodicity in the velocity of

the slow recovery phase can be seen in Fig. 6 a.

Occasionally, cells were irradiated less than 1 s after a spontaneous arrest had taken place (Fig. 6 b). In these cases, the initial wing-shaped response disappeared, and only the slower recovery from the margin was observed. When the cells were irradiated while the cilia on them were undergoing a

spontaneous arrest, the irradiation did not affect the initial response, but the slow recovery phase appeared in the records (Fig. 6 c).

HIGH Ca^{++} : In artificial seawater containing high Ca^{++} (82.4 mM, Fig. 5 d) the velocity of the spread of the laser-induced arrest was about 3 times faster than in normal seawater, and the extent of spread was greater (Table I). Recovery was again biphasic, and the duration of arrest of cilia in the initial fast recovery phase was independent of the distance from the lesion but was somewhat erratic. Spontaneous arrest was also observed in high Ca^{++} .¹

In one preparation in artificial seawater containing 100 mM Ca^{++} , an anomalous result was obtained in which the usual fast spread of arrest was not observed (Fig. 7). Instead, the record shows an unusually slow spread of arrest followed by a typical recovery that is clearly periodic. Here, spread occurred at speeds entirely comparable to those found for laser-induced ciliary arrest in *Elliptio* (Table II). The size of the recovery steps

(ca. 10 μ m) suggests that recovery may occur in sequence cell by cell.

We conclude that the gill filament is capable of producing two distinct arrest responses. Although these cannot yet be distinguished on the basis of velocity of speed of arrest, they are easily classified on the basis of recovery as (a) a nondecremental response whose duration does not vary significantly with distance from the initial stimulus and (b) a decremental response where arrest nearer the stimulus point is much longer lasting. The first response occurs over relatively large portions of a gill filament spontaneously and sometimes as an initial event after laser irradiation, while the second is more confined and associated solely with the irradiation.

The Activation of Lateral Cilia Beat

In the foregoing experiments, we investigated the effects of laser irradiation on beating cilia. Here we describe the effects on nonbeating cilia. When the medium contained no 5-HT, the lateral cilia were usually quiescent. Laser irradiation of

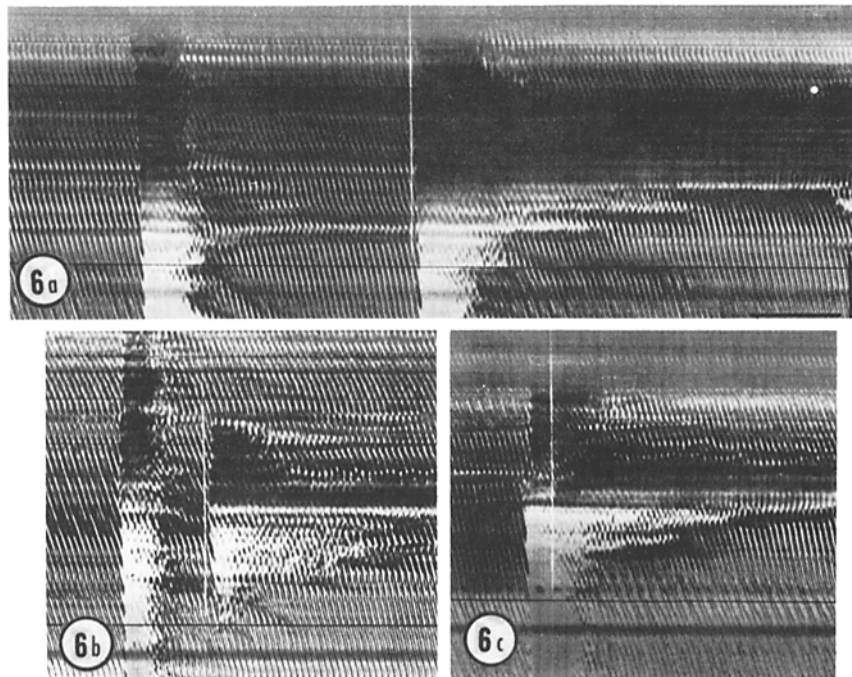

FIGURE 6 Slit camera records of spontaneous vs. laser-induced spreading ciliary arrest in low (1 mM) Ca^{++} . All solutions contain 10^{-7} M 5-HT. Vertical scale: 50 μ m. Horizontal scales: 0.5 s. White line indicates time of laser firing. (a) Laser-induced arrest occurs several seconds after spontaneous arrest. Note stepwise recovery from induced arrest. (b) Arrest is induced by laser irradiation within 1 s after spontaneous arrest. (c) Laser irradiation during spontaneous arrest.

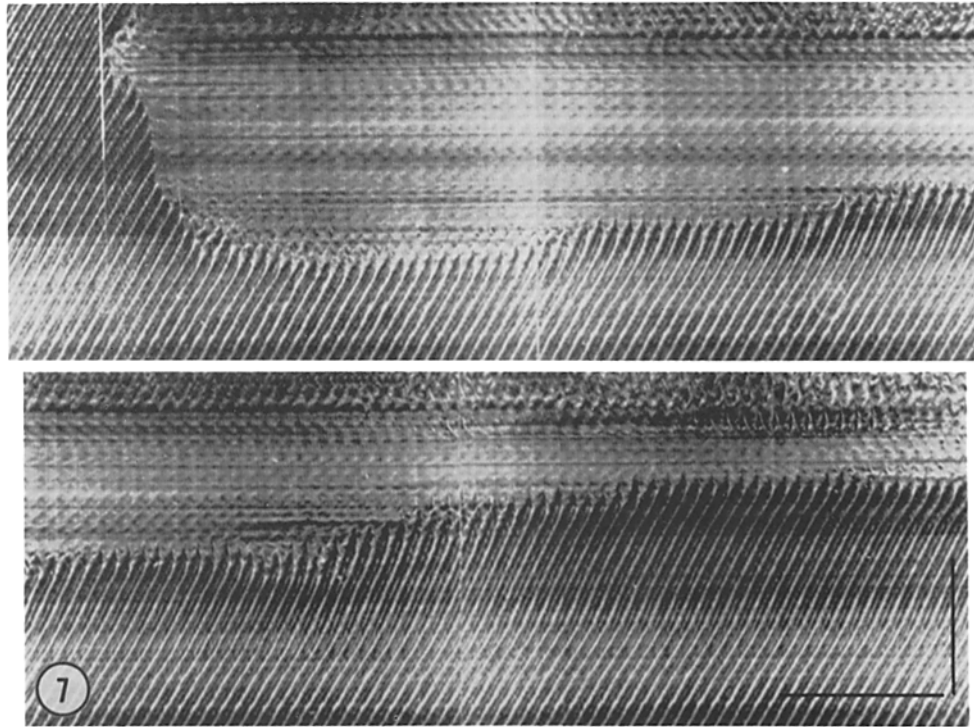

FIGURE 7 Slit camera records of slow spreading arrest in 100 mM Ca^{++} . Solution contains 10^{-7} M 5-HT. Lower record is a continuation of upper record. Vertical scale: 50 μm . Horizontal scale: 0.5 s. Laterofrontal cirri can be seen beating in region where lateral cilia are arrested. Note periodic recovery in steps approximating cell size (10 μm). White line indicates time of laser firing.

nonbeating cilia activated the beat. Several seconds after the irradiation, the activation began first around the lesion and proceeded outward from either side of the lesion. The speed of the spread was several micrometers/second (average), but it was not uniform. Thus, sometimes it increased to several 100 $\mu\text{m}/\text{s}$ for 10–100 ms and then returned to normal. Therefore, the spread of the activation looked like a staircase, whose step size was 2–16 μm . The final extent of the spread of activation was more than the limit of the recording system (130 μm). The activated cilia beat in synchrony or with metachronism whose wavelength was much longer than that observed in the cilia activated by 5-HT.

Rarely, in the medium without 5-HT, lateral cilia were beating on a part of the filament. When such a region was irradiated, the usual spreading ciliary arrest was produced. The arrest spread to >130 μm to either side of the lesion. Now, however, recovery began first around the lesion and spread to both margins of the stopped region in a manner very similar to that of the spread of

activation in adjacent nonbeating areas of the filament.

Laterofrontal Cilia

When we were irradiating the lateral cells, sometimes we focused the laser so that instead the laterofrontal cells (Fig. 1) were irradiated. Laterofrontal cilia also responded to the irradiation with a spreading arrest (Fig. 8).

Laterofrontal cilia are compound cirri acting in unison on one cell. As the image of a beating cirrus intercepted the slit, a gray square was produced on our records (Fig. 2). Cirri on adjacent cells, spaced about 2.5 μm apart, beat synchronously (vertical line connecting adjacent squares) or metachronally (sloping line connecting adjacent squares) for short distances. While the beat frequency in normal seawater with or without 5-HT was about 7 beats/s, much slower than the lateral cilia frequency, the metachronal wavelength was often 10 μm , about the same as that of the lateral cilia. When a laser lesion was produced, a spreading arrest of the cirri occurred both in normal seawater

and in high Ca^{++} (100 mM), irrespective of whether the solution contained 5-HT. When a cirrus stopped it took a bent form, and the squares disappeared from the records. The cirri near the lesion stopped first, and the stoppage spread along the gill filament to both sides of the lesion. The average velocity of the spread was 2–7 $\mu\text{m/s}$, exceedingly slow compared to the velocity of lateral cilia arrest. The velocity of the spread was not uniform. Often about four cirri in line (10 μm) stopped with time differences shorter than 1 s. After a lag of several seconds, the next group of several cirri stopped within 1 s, and so on. In contrast to lateral cilia, the beat frequency of laterofrontal cilia gradually decreased before cirri stopped. Sometimes some cirri kept beating long after cirri more distal to the lesion had stopped. The slow spread enabled us to observe the phenomenon directly through the microscope. The extent of the spread was from 40 μm to more than the limit of the microscope field (300 μm) to either side of the lesion. The duration of arrest was from several minutes to several 10's of minutes. The recovery began from the margins of the

stopped area. Some cirri remained quiescent when adjacent cirri more proximal to the lesion had recovered. Sometimes laser irradiation in the medium without 5-HT induced the stoppage of laterofrontal cilia and subsequently activation of lateral cilia (Fig. 8).

DISCUSSION

Absorption of the laser radiation by the blue dye produces an instantaneous local temperature increase by which cells in the immediate vicinity of the point of focus of the radiation are damaged. Cilia in the damaged area, at a locus of <30 μm from the point of focus, never resume normal beating. Outside of this area, both the cilia and the underlying cells are normal both morphologically (Satir et al., 1972) and also with respect to the continuity or resumption of normal ciliary beat. The damage interrupts epithelial integrity.

Metachronal Wave Coordination Is Mechanical

Our results support the hypothesis that metachronism is mechanically coordinated. As would

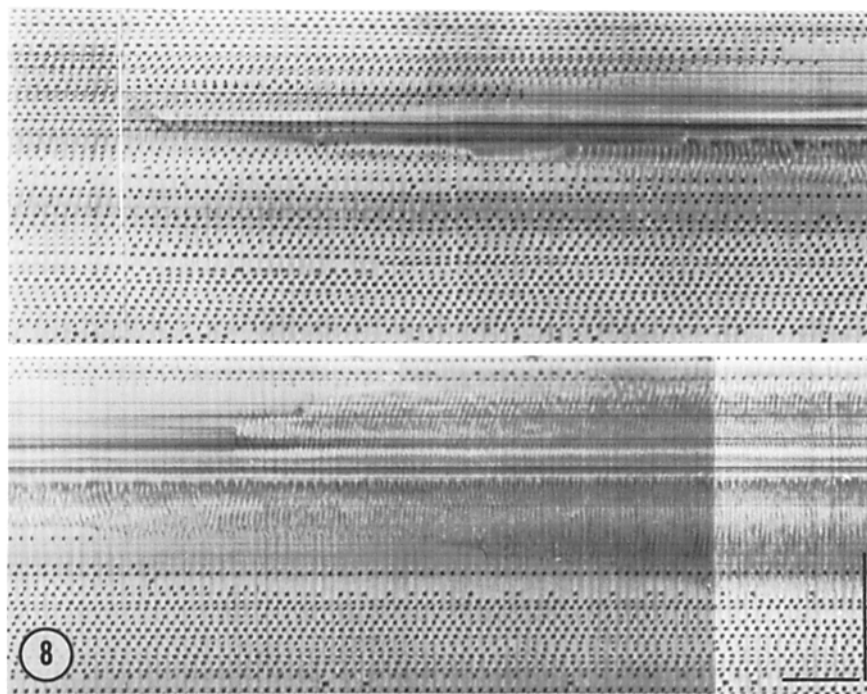

FIGURE 8 Slit camera records of laterofrontal cilia in 100 mM Ca^{++} , no 5-HT. Lower record is a continuation of upper record. Vertical scale: 50 μm . Horizontal scale: 1 s. Laterofrontal cirri beat is arrested slowly in spreading fashion from point of laser irradiation. After several seconds, synchronous lateral ciliary beat begins. See text for details. White line indicates time of laser firing.

be expected if metachronal wave propagation depended upon local mechanical coupling between cilia, the laser lesion introduces small perturbations to both sides of the lesion with respect to wave parameters such as frequency synchronization and wave velocity. In artificial seawater that contains high K^+ or is effectively Ca^{++} -free, these comparatively minor changes in coordination are detectable on our records. The changes appear to be somewhat dependent on position, so that velocity usually increases to the downhill side of the metachronal wave and decreases to the uphill side, as if average wave velocity depends on phase relationships between cilia entrained over long distances. We also found that, upon recovery from ciliary arrest, beating is synchronous for a few periods, until it presumably becomes integrated into the ongoing wave via viscous interaction with neighboring cilia. These results, together with those of Machemer (1972) and Eckert and Naitoh (1970), support the interpretation that the mechanical interactions between adjacent cilia produce metachronal waves in which there is minimal interference with three-dimensional beat. Aiello and Sleight (1972) have studied the form of beat of *Mytilus* lateral cilia, which they find has a three-dimensional component, as originally suggested by Párducz (1967) for *Paramecium* and by Satir (1963) for *Elliptio*. After much controversy, it now seems clear that metachronism is independent of membrane events. Models of *Paramecium* (Naitoh and Kaneko, 1973) and perhaps of gill cilia (Child and Tamm, 1963), where the membrane is disrupted so that resting potential is lost, can still beat metachronally when reactivated by ATP.

Laser-Induced Arrest Is Not Mechanically Coordinated

Nevertheless, electrical or neuroidal events centered on changes of membrane permeability have an effect on cilia. Eckert (1972) has summarized the findings for *Paramecium*, the organism best studied in this regard, where membrane depolarization induces ciliary reversal. The essential similarity between ciliary arrest in metazoan epithelia and reversal in ciliates has been noted previously (Takahashi, 1971). A recent study by Mackie et al. (1974) provides convincing evidence for the association of ciliary arrest and electrical events in an ascidian epithelium. These workers correlate arrest with a potential change that leads to Ca^{++} influx, in much the same way as we suggest below.

In our experiments under appropriate ionic conditions, in addition to local damage, laser irradiation induces distinct arrest responses of the lateral cilia, where cilia are arrested in sequence depending on stroke position and distance from the lesion. Although these responses are still indistinguishable on the basis of the mode or velocity of spread of the arrest, on the basis of recovery mode two responses types are found (a) a nondecremental response which resembles spontaneous stoppage, and (b) a decremental response, where arrest nearer the stimulus point is much longer lasting.

The arrest spreads symmetrically around the point of stimulation anywhere along the gill filament without regard to the metachronal wave direction. The velocity of spread is much faster than metachronal propagation, and the occurrence is strictly ion dependent. Since all mechanical parameters and local heating conditions are identical in the experiments where ionic conditions give lesions without spreading arrest and since neither lesions nor arrest occur without exact focusing of the laser, we conclude that the arrest is not due to the spread of heated medium, shock waves, or similar physical changes, but is a consequence of changes probably related to the cell membrane. Therefore, it seems that arrest is produced by mechanisms different from those responsible for metachronism. Spreading arrest also occurs in laterofrontal cilia, but with very different kinetics.

Laser-Induced Arrest Is Fundamentally Similar to Other Arrest Responses of Gill Cilia

In the freshwater mussel, *Elliptio*, Satir et al. (1972) have shown that laser irradiation produces a spreading arrest of the lateral cilia similar to the decremental response we observe here. The kinetics of arrest differ somewhat from those in *Mytilus*. Although the major features shown here are still incompletely documented for *Elliptio*, the mechanisms of arrest seem essentially identical, and such differences as occur are readily accounted for by phylogenetic variation in the two organisms in the structure of the gill, lateral cell size (25 μm long in *Elliptio* vs. 10 μm long in *Mytilus*) and by changes in the ionic environment.

The stoppage responses are obviously not specific to laser stimulation; instead, they probably depend on mechanisms inherent to the gill epithelium. Such mechanisms may be physiologically significant in that they would shut off flow of water

over the gill in certain adverse environmental conditions. For example, in *Mytilus* gill cilia,¹ arrest responses can also be produced by mechanical stimulation. Mechanical stimulation induces an arrest that resembles the laser-induced decremental response, except that the duration is shorter (70 ms at the margin) and the velocity is faster (500 $\mu\text{m/s}$). Finally, in high K^+ and Ca^{++} -free solutions, mechanical stimulation fails to induce spreading ciliary arrest. Electrical and chemical stimulation of the gill epithelium also may produce ciliary arrest, but in these cases stimulation generally has not been applied as locally, and correspondingly the arrest does not spread outward from the point of stimulation. Particularly, our results with the lateral cilia resemble those of Baba et al.² where electrical stimulation arrests these cilia with different time-courses, dependent on stroke positions. During stoppage, the cilium is pulled back to a unique rest position near the beginning of the effective stroke. We clearly demonstrate (Fig. 4) that arrest occurs in a characteristic order that is the same in every metachronal wavelength regardless of the direction of the metachronal wave with respect to the spread of arrest. The periodicity of arrest, therefore, depends on stroke position and apparently not upon the position of the cell borders along the epithelium; we are unable to pick up any effective delay in the spread of lateral cilia arrest at cell borders. However, the periodicity associated with recovery (Figs. 6 *a* and 7) or with the slow arrest of laterofrontal cilia (Fig. 8) may be due to such delay.

It is interesting that the laterofrontal cilia generally function independently of the lateral cilia. For example, they usually continue to beat when the lateral cilia are arrested. However, there is coupling between the inactivation of laterofrontal cilia and activation of lateral cilia, and the period seen during the spread of laterofrontal inactivation resembles lateral rather than laterofrontal cell size.

Diffusion Can Account for Slow Spreading Activation of Quiescent Lateral Cilia, But Not for Arrest

Because the target cells are perforated at the instant of laser irradiation, which acts as the stimulus for arrest, they may release substances that diffuse away from the point of stimulation.

² Baba, S. A. Personal communication.

Additionally, an injury potential may be generated. Since both chemical and electrical stimulation cause stoppage, either (*a*) diffusion or (*b*) spread of a potential change could be effective local stimuli causing the spread of stimulation in our laser experiments.

The activation of quiescent cilia by laser irradiation could similarly be explained by either of these alternative hypotheses. Aiello (1960) has shown that local mechanical damage to *Mytilus* gill filaments causes release of 5-HT from the disrupted region. Release of 5-HT at the laser lesion could account in part for activation of quiescent lateral cilia in synchronous beat and recovery from the center after laser irradiation in solutions without exogenous 5-HT. The slow velocity of spread of such activation (a few micrometers/second) is consistent with this explanation.

In solutions with exogenous 5-HT, after laser-induced arrest, recovery from the center is sometimes observed. This recovery also has a slow velocity of spread and is associated with synchronously beating cilia (Fig. 3 *c*). Although the velocity and coordination are similar to recovery from the center in medium without 5-HT, diffusion of 5-HT evidently cannot explain the recovery in this case. However, Takahashi and Tsuchiya (1971) have observed synchronous beating in lateral cilia placed in seawater rich in K^+ . Presumably, K^+ could also be released from the disrupted cells. In several instances, therefore, we have observed slow phenomena associated with ciliary activation, whose spread is entirely consistent with a diffusion mechanism. These examples provide some measure of velocity of spread that could be expected from diffusion in the gill ciliary system. The spread of lateral cilia arrest occurs much more rapidly (10^2 – 10^4 $\mu\text{m/s}$; see Table II) than the spread of such activation and is correspondingly difficult to account for by diffusion. Moreover, the ionic sensitivity of the arrest of the lateral cilia, the sequence of arrest within one metachronal wavelength, and the similarity to mechanically stimulated arrest, support the suggestion that the laser induces a local injury current, which then spreads smoothly from cell to cell by electrical means.

The Decremental Arrest Response Depends Upon Electrotonic Spread of Potential Change Produced at the Stimulus Site

The lateral cilia are under neural control. Stimulation of the branchial nerve induces stoppage

(Takahashi and Murakami, 1968) but the characteristics of the arrest are somewhat different from those of laser-induced stoppage. For example, the velocity of spread is much faster in the neurally induced arrest (Table II). While nervous excitation may be the underlying stimulus that initiates arrest in physiological situations, we think it unlikely that the decremental response is caused primarily by stimulation of the underlying nervous tissue. The geometry would appear to rule out simple field effects. Unfortunately, the synaptic connections between nerves and epithelial cells are not worked out as yet for lamellibranch gill tissue: to insure smooth spread of arrest, regardless of where along the filament stimulation is applied, epithelial-nervous connections would have to be exceedingly complex.

Again, a plausible alternative is that the laser induces electrical changes, and, in all probability, a membrane depolarization in the epithelial cells themselves. Gill cells are connected by septate and gap junctions (Gilula and Satir, 1971) and are probably electrically coupled so that electrical changes will spread across cell borders. The decremental response would then be dependent on an electrotonic spread of injury potential produced at the stimulus site, and may classically be called neuroidal (Mackie, 1970). If depolarization were coupled to transient changes in Ca^{++} permeability of the cell membrane, the local rise in internal Ca^{++} concentration might inhibit ciliary beat at a sensitive point in the stroke cycle. Similar events without permanent injury probably occur after mechanical stimulation. This is the type of transduction sequence that has been considered for mechanoreceptive phenomena in ciliary-based systems in general (Thurm, 1968; Eckert, 1972; Moran and Varela, 1971; Gilula and Satir, 1972; Mackie et al., 1974).

The Nondecremental Arrest Has Features of a Regenerative Response

Under specific ionic conditions, we envision that the epithelial cells, either alone or in conjunction with the branchial nerve, are capable of a regenerative response to the injury potential. This would increase the extent of the arrest and change the response to the nondecremental type that we observe. Brief, unplanned, mechanical stimulation that elicits such a response is probably the cause of spontaneous arrest during which only decremental responses can be produced. At this time, we are unable to account completely for the role of Ca^{++}

in the production of nondecremental responses. It is interesting, however, that high Ca^{++} usually increases the velocity of the spread of arrest threefold. Although we have recently been able to penetrate *Mytilus* gill cells with microelectrodes and have recorded resting potentials of up to 20 mV, we are as yet unable to demonstrate electrical changes after laser stimulation in the cells directly.

The lateral cilia of lamellibranch gill epithelia are, of course, effectors, but they also have receptor functions, including mechano- and chemoreception. Our present results suggest that ciliary arrest is brought about by neuroidal responses that are essential to such receptor activity. The spread of arrest is probably dependent on the proper coupling between epithelial cells via cell junctions, and possibly on epithelial nervous interactions as well. Therefore, this ciliated epithelium provides an extremely interesting model system, not only for the study of ciliary motion, but for certain problems in sensory and neurophysiology as well.

We thank Professor K. Takahashi for the use of facilities and Professors Takahashi, Akita and Terayama for extending the hospitality of the Zoological Institute to Dr. Satir. We are grateful to Professor Takahashi and Dr. S. Baba for helpful discussion and advice, and to Ms. Paulette Setzer and Ms. Jean Schiffman for help in preparation of the ms.

One of us (Dr. Satir) undertook this project as a fellow of the John Simon Guggenheim Foundation and wishes to acknowledge their generous assistance and support. This work was also supported in part by the USPHS (HL13849) and the NSF US-Japan exchange program.

Received for publication 20 December 1974, and in revised form 28 March 1975.

REFERENCES

- AIELLO, E. L. 1960. Factors affecting ciliary activity on the gill of the mussel *Mytilus edulis*. *Physiol. Zool.* **33**:120-135.
- AIELLO, E. L., and M. A. SLEIGH. 1972. The metachronal wave of *Mytilus edulis*. *J. Cell Biol.* **54**:493-596.
- CHILD, F. M., and S. L. TAMM. 1963. Metachronal ciliary co-ordination in ATP-reactivated models of *Modiolus* gills. *Biol. Bull. (Woods Hole)*. **125**:373-374.
- ECKERT, R. 1972. Bioelectric control of ciliary activity. *Science (Wash. D. C.)*. **176**:473-481.
- ECKERT, R., and Y. NAITOH. 1970. Passive electrical properties of *Paramecium* and problems of ciliary coordination. *J. Gen. Physiol.* **55**:467-483.
- GILULA, N. B., and P. SATIR. 1971. Septate and gap

- junctions in molluscan gill epithelium. *J. Cell Biol.* **51**:869-872.
- GILULA, N. B., and P. SATIR. 1972. The ciliary necklace. A ciliary membrane specialization. *J. Cell Biol.* **53**:494-509.
- GOLDSTEIN, S. 1969. Irradiation of sperm tails by laser microbeam. *J. Exp. Biol.* **51**:431-441.
- GOLDSTEIN, S. 1972. Effects of laser irradiation on the structure and function of cilia and flagella. *Acta Protozool.* **11**:259-264.
- GRAY, J. 1930. The mechanism of ciliary movement. IV. Photographic and stroboscopic analysis of ciliary movement. *Proc. R. Soc. Lond. B. Biol. Sci.* **107**:313-332.
- LUCAS, A. M. 1932. Co-ordination of ciliary movement. I. *J. Morphol.* **53**:243-263.
- MACHEMER, H. 1972. Properties of polarized ciliary beat in *Paramecium*. *Acta Protozool.* **11**:295-300.
- MACKIE, G. O. 1970. Neuroid conduction and the evolution of conducting tissues. *Q. Rev. Biol.* **45**:319-332.
- MACKIE, G. O., D. H. PAUL, C. M. SINGLA, M. A. SLEIGH, and D. E. WILLIAMS. 1974. Branchial innervation and ciliary control in the ascidian *Corella*. *Proc. R. Soc. Lond. B. Biol. Sci.* **187**:1-35.
- MORAN, D. T., and F. G. VARELA. 1971. Microtubules and sensory transduction. *Proc. Natl. Acad. Sci. U. S. A.* **68**:757-760.
- MURAKAMI, A. 1968. Response of cilia to electrical stimulation of *Mytilus* gill. *J. Fac. Sci. Univ. Tokyo Sect. IV Zool.* **11**:373-384.
- NAITOH, Y. and H. KANEKO. 1973. Control of ciliary activities by adenosine triphosphate and divalent cations in triton extracted models of *Paramecium caudatum*. *J. Exp. Biol.* **58**:657-676.
- PÁRDUCZ, B. 1967. Ciliary movement and coordination in ciliates. *Int. Rev. Cytol.* **21**:91-128.
- SATIR, P. 1963. Studies on cilia. The fixation of the metachronal wave. *J. Cell Biol.* **18**:345-365.
- SATIR, P., I. FONG, and S. F. GOLDSTEIN. 1971. Neuroid transmission: intercellular spread of laser induced ciliary arrest. Proceedings of the 11th Annual Meeting of the American Society for Cell Biology. 260 a. (Abstr.).
- SATIR, P., I. FONG, and S. F. GOLDSTEIN. 1972. Laser induced neuroid transmission in a ciliated epithelium. *Acta Protozool.* **11**:287-290.
- SEGERDAHL, E. 1922. Investigations on the effect of a direct electric current on the ciliary motion of the *Anodonta* gill. *Skand. Arch. Physiol.* **42**:359-372.
- TAKAHASHI, K. 1971. Abrupt stoppage of *Mytilus* cilia caused by chemical stimulation. *J. Fac. Sci. Univ. Tokyo Sect. IV Zool.* **12**:219-228.
- TAKAHASHI, K., and M. MURAKAMI. 1968. Nervous inhibition of ciliary motion in the gill of the mussel *Mytilus edulis*. *J. Fac. Sci. Univ. Tokyo Sect. IV Zool.* **11**:359-372.
- TAKAHASHI, K., and T. TSUCHIYA. 1971. The action of potassium ions on *Mytilus* cilia. *J. Fac. Sci. Univ. Tokyo Sect. IV Zool.* **12**:229-239.
- THURM, U. 1968. Steps in the transducer process of mechanoreceptors. *Symp. Zool. Soc. Lond.* **23**:199-216.
- TSUCHIYA, T., and K. TAKAHASHI. 1972. Calcium and the activity of cilia on the gill of the mussel, *Mytilus edulis*. *Annot. Zool. Jpn.* **44**:57-64.