

# Concanavalin A Induces Interactions between Surface Glycoproteins and the Platelet Cytoskeleton

RICHARD G. PAINTER and MARK GINSBERG, *with the technical assistance of*  
BRYON JAQUES

*Department of Immunopathology, Research Institute of Scripps Clinic, La Jolla, California 92037*

**ABSTRACT** We have measured the association of platelet surface membrane proteins with Triton X-100 (Triton)-insoluble residues in platelets surface labeled with  $^{125}\text{I}$ . In both concanavalin A (Con A)-stimulated and resting platelets, this fraction is composed largely of polypeptides with apparent molecular weights of 45,000, 200,000, and 250,000 which comigrate with authentic actin, myosin heavy chain, and actin binding protein, respectively, as judged by PAGE in SDS. Less than 10% of the two major  $^{125}\text{I}$ -labeled surface glycoproteins, GPIIb and GPIII, were associated with the Triton residue in resting platelets. Within 45 s after Con A addition, 80–95% of these two glycoproteins became associated with the Triton residue and the amount of sedimentable actin doubled. No cosedimentation of GPIIb and III with the cytoskeletal protein-containing Triton residue was seen when Con A was added to a Triton extract of resting cells, indicating that the sedimentation of GPIIb and III seen in Con A-stimulated platelets was not due to precipitation of the glycoproteins by Con A after detergent lysis. Treatment of Triton extracts of Con A-stimulated platelets with DNase I (deoxyribonuclease 5'-oligonucleotidohydrolase [EC 3.1.4.5]) inhibited the sedimentation of actin and the two surface glycoproteins in a dose-dependent manner. This inhibition of cosedimentation was not due to an effect of DNase I on Con A-glycoprotein interactions since these two glycoproteins could be quantitatively recovered by Con A-Sepharose affinity absorption in the presence of DNase I. When the Con A bound to the Triton residue was localized ultrastructurally, it was associated with cell-sized structures containing filamentous material. In intact cells, there was simultaneous immunofluorescent coredistribution of surface-bound Con A and myosin under conditions which induced a redistribution of platelet myosin. These data suggest that Con A can, in the intact platelet, induce physical interactions between certain surface glycoproteins and the internal cytoskeleton.

There is a considerable immunohistochemical and some biochemical evidence suggesting that cell surface proteins and glycoproteins interact in a transmembrane manner with the cell cytoskeleton, especially after surface proteins have been aggregated by multivalent ligands (1, 2, 5, 6, 21–23, 32).

Elucidation of the molecular architecture of this complex of surface proteins and the cytoskeleton requires cells in which the cytoskeleton with associated surface proteins can be isolated in bulk and in a relatively pure and intact state. The human platelet appears to meet these criteria. In addition, the glycoprotein composition of the platelet surface has been well-characterized (4, 19, 26–28). Phillips and his co-workers (29) have recently shown that two major surface glycoproteins, designated GPIIb and GPIII, become associated with platelet

cytoskeletons isolated by centrifugation of Triton X-100 (Triton) extracts of thrombin-aggregated platelets. Furthermore, cytoskeletons isolated by such procedures at least in activated platelets are relatively intact structures as judged by electron microscopy (20) and are composed of polypeptides with properties of the major cytoskeletal proteins, actin, myosin, and actin-binding protein (29).

In the studies reported to date it was not clear whether the apparent association of platelet surface glycoproteins could be induced by stimuli other than thrombin. Furthermore, it was not certain whether the observed interactions of surface glycoproteins with the cytoskeleton were induced in the intact cell or occurred, *post facto*, as a result of detergent lysis. In order to address these questions, we have examined the effect of con-

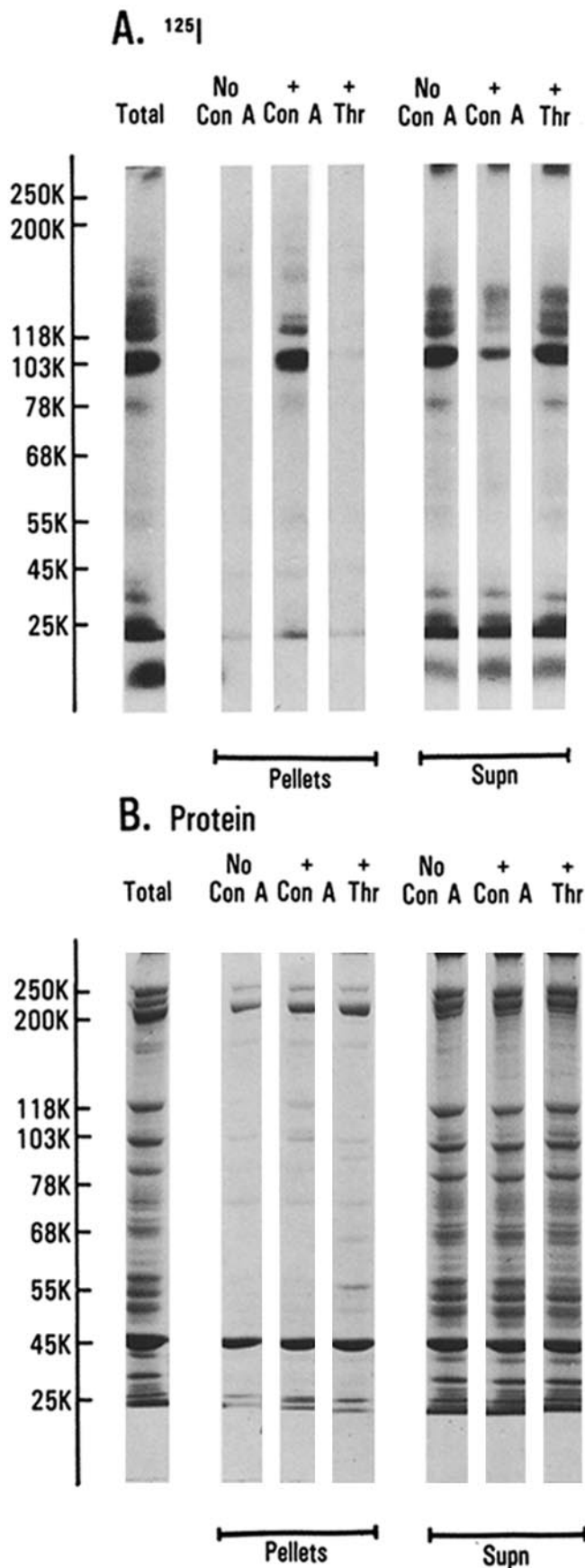

FIGURE 1 SDS PAGE of <sup>125</sup>I-surface-labeled platelet cytoskeletal protein-rich pellet (pellets) and soluble supernatant (supn) fractions obtained by centrifugation of platelets extracted with Triton X-100. (A) Autoradiogram and (B) corresponding Coomassie Blue protein-

canavalin A (Con A) on the association of platelet surface glycoproteins with the platelet cytoskeleton. We will present biochemical as well as morphological evidence which shows that Con A induces physical interactions between the cytoskeleton and surface glycoproteins in the intact platelet. A preliminary report of these data has appeared (11).

## MATERIALS AND METHODS

### Cells

Human platelets were washed by gel filtration on Sepharose 2B columns (Pharmacia, Fine Chemicals, Uppsala, Sweden) (34) as described elsewhere (12). All subsequent washing steps were performed at 10°C using TBS (30 mM Tris-HCl 120 mM NaCl), pH 6.5 by centrifugation at 2,400 rpm in an International PR-6 centrifuge for 20 min and the washed cells suspended in TBS, pH 7.4 (10).

### Iodination of Surface Proteins

Platelets were labeled with <sup>125</sup>I using a modification of the lactoperoxidase technique of Phillips and Agin (27). 0.5 mCi of Na <sup>125</sup>I (Amersham Corp., Arlington Heights, Ill.; carrier free) was added at room temperature to 2 × 10<sup>8</sup> platelets in 2 ml of TBS, pH 7.4. 40 μg of lactoperoxidase (Calbiochem-Behring Corp., La Jolla, Calif.) in 20 μl was added and the reaction started by adding 10 μl of freshly prepared 1 mM H<sub>2</sub>O<sub>2</sub> followed by 10-μl additions at 1-min intervals for a total of 10 additions. 1 ml of a suspension containing 3.8 × 10<sup>9</sup> unlabeled platelets was added and the suspension washed twice by centrifugation at 10°C after addition of 12 ml of TBS, pH 6.5. The labeled cells (before addition of unlabeled carrier cells) were capable of shape change and serotonin release in response to thrombin. More than 90% of the cell-associated label was removed from the cell pellet by treatment with 200 μg/ml chymotrypsin (Worthington Biochemical Corp., Freehold, N. J.) for 15 min at 37°C. In addition, no appreciable labeling of intracellular proteins (i.e., actin and myosin) was noted (Fig. 1) even though these proteins could be iodinated if the cells were lysed by freeze-thawing before labeling.

### Experimental Protocol

0.19 ml of 2 × 10<sup>8</sup> <sup>125</sup>I-labeled gel-filtered platelets was preincubated for 10 min at 37°C. 10 μl of Con A was added at the specified final concentration. After mixing, the cells were incubated without shaking for 15 min at 37°C. The reaction was terminated by adding 0.20 ml of 4% Triton (Rohm and Haas Co., Philadelphia, Pa.)/4 mM EDTA dissolved in TBS, pH 7.4. The incubation was continued for 10 min at 37°C. The samples were then centrifuged for 30 min at 20,000 rpm using an SS-34 rotor in a Sorvall RC-5 centrifuge (DuPont Co., Wilmington, Del.) at 4°C. The supernatant was carefully removed and the gelatinous pellet dissolved in 500 μl of 4% SDS/10% β-mercaptoethanol (β-ME)/2 mM EDTA. 100 μl of 20% (vol/vol) SDS and 50 μl of β-ME were added to the remaining supernatant fraction. Both the pellet and supernatant fractions were immediately incubated in a boiling water bath for 4 min and 50-μl aliquots analyzed by SDS PAGE as described below.

### SDS PAGE

One-dimensional slab gels were prepared and run as described by Laemmli (16) using a running gel containing either 8% acrylamide or a 7–15% gradient of acrylamide. The slabs were 9 cm high, 13 cm wide, and 0.15 cm thick. A 1-cm high 3% stacking gel was used in all cases. Electrophoresis was carried out at a constant voltage of 20 V for 18 h. After staining with Coomassie Blue R250, the destained wet gels were analyzed by quantitative densitometry if desired (see below) and then dried with a Bio Rad slab gel dryer model SE 540 (Bio-Rad Laboratories, Richmond, Calif.). Autoradiography was carried out by storing the dried gels next to RP x-ray film (Kodak, Rochester, N. Y.) for 5–18 h at -70°C in the presence of an intensifying screen. Molecular weight standards included:

staining pattern. Viable <sup>125</sup>I-labeled platelets were treated for 20 min at 37°C before Triton X-100 addition with (from left to right) no Con A, Con A (100 μg/ml final), or thrombin (Thr). The total cellular <sup>125</sup>I-labeling and protein patterns are seen at far left as indicated. Note that the two major <sup>125</sup>I-labeled components, GPIII and GPIIb (as α chain), were completely extracted by Triton X-100 in unstimulated platelets (i.e., no Con A or Thr). After stimulation with Con A, nearly all the radioactivity associated with GPIIb and III was found in the pellet fraction.

uterine actin-binding protein (250,000) purified as described by Wallach et al. (36), rabbit skeletal muscle myosin (200,000), lactoperoxidase (78,000), bovine serum albumin (68,000; Sigma Chemical Co., St. Louis, Mo.), heavy (55,000) and light chains (23,000) of rabbit immunoglobulin G (Cappel Labs, Cochranville, Pa.) and rabbit skeletal actin (45,000) prepared as described by Spudich and Watt (33).

### Quantitation of $^{125}\text{I}$ -labeled Surface Components

Radioactivity associated with individual surface-labeled components was quantitated by cutting the individual bands out of the dried gel. In all cases where this was done, the radioactive bands were identified both by autoradiography and by staining with Coomassie Blue before excision. Radioactivity of the excised bands was determined in a Searle well-type gamma counter. The radioactivity associated with each individual band in the supernatant and pellet fractions was corrected for average background (which was in all cases <15% of the total recovered radioactivity for each band), and the percent of recovered radioactivity associated with the pellet was calculated. Data points represent an average of two duplicates which varied by <10%. In all cases the sum of radioactivity in the pellet and supernatant fractions for each band accounted for >90% of that observed in the whole cells.

### Quantitation of Actin

Actin content of the pellet and supernatant fraction was determined by quantitative densitometry of the 45,000-dalton peptide seen on Coomassie Blue gels using a Zeineh soft laser densitometer (Biomed Instruments, Inc., Chicago, Ill.) equipped with an integrator. This peptide has been previously shown to be composed almost entirely of actin as shown by its ability to bind to DNase I-Sepharose (29). More than 90% of the total actin was accounted for by the sum of that present in the pellet and supernatant fraction.

### DNase I Treatment of Triton Extracts

To assess the effect of DNase I (deoxyribonucleate 5'-oligonucleotididohydrolase) on the Triton residue, DNase I (Sigma Chemical Co.) was pretreated with 0.5 mM phenylmethyl sulfonyl fluoride and was added with the Triton buffer at final concentrations of 0.1–1.6 mg/ml. After 30 min at 37°C (in preliminary experiments, maximal inhibition of actin sedimentation was observed at this time), the Triton lysates were centrifuged and analyzed as described above. Preliminary assays showed that 0.81 equivalent of actin inhibited the enzymatic activity of 1 equivalent of the DNase I preparation used assayed as described by Lazarides and Lindberg (17).

### Binding of Triton-solubilized Platelet Surface Glycoproteins to Con A-Sepharose

The binding of platelet glycoproteins to Con A-Sepharose 4B was measured as follows:  $^{125}\text{I}$ -surface-labeled resting platelets ( $1 \times 10^8$  in 1 ml of TBS) were lysed with 0.1 vol of 20% Triton/20 mM EDTA in either the presence or absence of up to 2 mg/ml (final) DNase I. After 30 min at 37°C, the lysates were centrifuged for 2 min in a Beckman microfuge (Beckman Instruments, Inc., Palo Alto, Calif.) and the glycoprotein-containing supernatants were collected. A 100- $\mu\text{l}$  aliquot of each supernatant was added to 300  $\mu\text{l}$  of washed Con A-Sepharose 4B (150- $\mu\text{l}$  packed gel bed; Pharmacia). After 15 min at ambient temperature, the suspensions were centrifuged in the microfuge and the gel pellets washed twice with 1 ml of TBS. The bound material was analyzed by SDS PAGE as described above and the amount of bound  $^{125}\text{I}$  GPIIb and III was analyzed by quantitative densitometry of autoradiograms as described above.

### Double-label Immunofluorescent Localization of Myosin and Con A

Gel-filtered platelets were treated with 100  $\mu\text{g}/\text{ml}$  of fluorescein-labeled Con A (Vector Labs, Burlingame, Calif.) for 10 min at 37°C and with 0.5 U/ml thrombin (a generous gift of Dr. John Fenton II, Albany, N. Y.), fixed with 2% formaldehyde, washed once with TBS by centrifugation, and applied to poly-L-lysine-coated 16-mm glass cover slips as described elsewhere (12). The fixed cells were then stained for myosin after treatment with 0.1% Triton, using affinity-purified goat anti-myosin antibody followed by counter-staining with rhodamine-labeled rabbit anti-goat IgG F(ab')<sub>2</sub> fragments as described elsewhere (13, 22, 25).

## Ultrastructural Localization of Con A on Ultrathin Frozen Sections of Triton Residues

$1 \times 10^8$  gel-filtered human platelets were incubated with biotinylated Con A (B-Con A; Vector Labs, Burlingame, Calif.) in 0.2 ml at a final B-Con A concentration of 50  $\mu\text{g}/\text{ml}$  at 37°C in TBS. As a control, a parallel aliquot of platelets was incubated with B-Con A in the presence of 50 mM  $\alpha$ -methyl-D-mannoside. After 3 min of incubation, the reaction was terminated by addition of an equal volume of 4% Triton (vol/vol)/4 mM EDTA and the lysates were centrifuged as described above. The pellets were fixed with 2% formaldehyde/0.5% glutaraldehyde/0.1 M Na phosphate buffer (pH 7.4) for 20 min, rinsed twice with buffer, and incubated in 0.75 M sucrose/0.1 M sodium phosphate (pH 7.4) for 1 h at 0°C. After mincing with a clean razor blade, a small piece was mounted on a copper block and frozen by immersion in liquid N<sub>2</sub> and frozen thin-sections were cut (~800–1000 Å) on a Sorvall MT2B ultramicrotome equipped with a cyrokit attachment as described elsewhere (12, 24, 35). The sections were stained with an avidin-gold colloid (16 nm) conjugate as follows: after mounting the sections on carbon-collodion-coated grids, the grids were incubated on a drop of avidin-Au<sub>16nm</sub> conjugate (0.57 nmol biotin-binding activity per ml) for 20 min in TBS buffer containing 2% gelatin. The grids were washed eight times by transferring them through large droplets of TBS buffer. The grids were then incubated in 2% glutaraldehyde/0.1 M Na phosphate buffer (pH 7.4) for 10 min, rinsed twice with H<sub>2</sub>O, and negatively stained with 1% uranyl acetate (pH 4.5). The specimens were examined at 75 kV in a Hitachi model HU 12A transmission electron microscope.

Gold colloid particles (16-nm average diameter) were prepared as described by Frens (7) and coated with avidin as follows: 40 ml of gold colloid solution (titrated to pH 8 with 0.2 M K<sub>2</sub>CO<sub>3</sub>) was added to 2 mg/ml of egg white avidin (Sigma Chemical Co.) which had been dialyzed vs. water before use. After 20 min, 1.5 ml of 1% polyethylene glycol (PEG<sub>1</sub>) (22,000 mol wt; Union Carbide Corp., New York) dissolved in H<sub>2</sub>O was added and the avidin-Au<sub>16nm</sub> conjugate isolated by centrifugation at 15,000 rpm for 1 h in a Sorvall (S-34 rotor) centrifuge at 4°C. The conjugate pellet was resuspended in TBS (pH 8) containing 0.02% PEG<sub>1</sub> and washed once more by centrifugation. The final conjugate was resuspended in a total volume of 1.2 ml of TBS-PEG buffer (pH 8) containing 1% bovine serum albumin and 0.1% NaN<sub>3</sub> and stored at 4°C. Titration of the conjugate with [<sup>14</sup>C]-D-biotin (59 mCi/mmol, Amersham Corp.) indicated that the conjugate had an active avidin concentration of 32  $\mu\text{g}/\text{ml}$  which is equivalent to ~7–8 molecules of active avidin bound per 16-nm particle, assuming that there are four biotin binding sites per molecule and that all the gold is present in particulate form.

## RESULTS

### Distribution of Surface-labeled Proteins in Triton Residues in Unstimulated and Stimulated Platelets

Centrifugation of Triton-solubilized  $^{125}\text{I}$ -surface-labeled platelets before the addition of any exogenous stimulus yielded a gelatinous pellet. Analysis by SDS PAGE of the pellet revealed major Coomassie Blue-staining bands with apparent molecular weights of 250,000, 200,000, and 45,000 which comigrated with authentic human uterine filamin and rabbit skeletal muscle myosin heavy chain and actin, respectively (Fig. 1B). In contrast, the major lactoperoxidase-labeled proteins, which in our gel system had apparent molecular weights of 123,000 and 105,000 daltons, respectively, were absent from this pellet fraction (Fig. 1A), being almost completely extracted by Triton. Determination of radioactivity associated with these  $^{125}\text{I}$ -labeled proteins showed that >80 and >95% of the radioactivity, respectively, was recovered in the supernatant fraction in unstimulated platelets.

After the addition of 100  $\mu\text{g}/\text{ml}$  of Con A to platelets for 30 min at 37°C before Triton addition, the Triton extractability of the two radioactive components was markedly decreased (Fig. 1A). More than 80% of both glycoproteins was now recovered in the pellet fractions. The observed effect of Con A was *not* seen if  $\alpha$ -methyl-D-mannopyranoside (50 mM) was added before Con A addition to the cells (not shown).

These two labeled surface proteins appear to be derived from

the two major surface glycoproteins of the platelet, GPIIb and GPIII (27), as defined operationally by (a) their mobilities in SDS gels under reduced and nonreduced conditions (27), (b) their ability to bind Con A (19), and (c) their absence in platelets obtained from patients with hereditary Glanzmann's thrombasthenia (28). The data supporting this identification will appear elsewhere (Jaques, B., and M. H. Ginsburg, submitted for publication). Therefore, we will subsequently refer to the 123,000- and 105,000-dalton peptides as GPIIb $\alpha$  and GPIII, respectively, and assume that the distribution of GPIIb $\alpha$  reflects the distribution of both disulfide-linked  $\alpha$  and  $\beta$  polypeptides of GPIIb.

To determine whether this redistribution of surface glycoproteins induced by Con A was the result of cell activation *per se*, cells treated with thrombin (0.5 U/ml) for 10 min at 37°C under nonstirred conditions were extracted with Triton, and the pellet and supernatant fractions were analyzed. Although these cells were activated as judged by serotonin secretion, GPIIb and III were *not* associated with the Triton pellet (Fig. 1A).

### The Effect of Con A Concentration on the Distribution of GPIIb and III in the Triton-insoluble Residue

To determine whether the amounts of sedimentable GPIIb and GPIII were associated with the quantity of added Con A, the effect of Con A concentration on the association of the two glycoproteins with the Triton residue was assessed. Fig. 2 shows the effect of varying Con A concentration on the distribution of GPIIb, GPIII, as well as <sup>125</sup>I-labeled Con A. In this experiment cells were incubated for 20 min at 37°C with 10–100  $\mu$ g/ml of <sup>125</sup>I-labeled Con A before Triton extraction and centrifugation. The faint Coomassie band associated with each component including the 25,000 mol wt band containing the Con A subunit was excised and counted for <sup>125</sup>I radioactivity. As can be seen, the percentage of total radioactivity recovered in the Triton-insoluble fraction increased with increasing Con A concentration and reached a maximal value of 93 and 98% for GPIIb and III, respectively. Microscopic examination of the intact, fixed platelets indicated that a change in shape from the initial discoid shape to a more rounded, irregular shape occurred at concentrations of Con A above 20  $\mu$ g/ml, but the cells remained monodisperse.

### Time-course of the Association of GPIIb and III with the Triton Residue

Fig. 3 shows the kinetics of the redistribution of the two glycoproteins after treatment of the cells with 100  $\mu$ g/ml <sup>125</sup>I-labeled Con A. As can be seen, the reaction is partially completed within 15 s after Con A addition and is essentially completed by 30–60 s. The amount of actin associated with the Triton-insoluble fraction increased about twofold, as judged by quantitative densitometry of the Coomassie Blue-stained gels, suggesting that this change is correlated with cell activation, a finding which agrees with previous data published by Phillips et al. (29) and Carlsson et al. (3). Assuming that Triton treatment completely stops the reaction (an assumption supported by the absence of the reaction at the zero time-point), these data indicate that the redistribution of GPIIb and III as well as the increase in actin associated with the Triton residue is maximal by 30–60 s at 37°C.

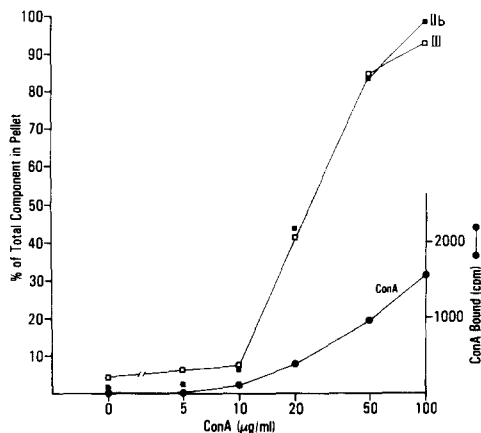

FIGURE 2 Dose dependence of Con A-induced cosedimentation of <sup>125</sup>I-surface-labeled platelet glycoproteins. <sup>125</sup>I-surface-labeled platelets were treated with increasing concentrations of <sup>125</sup>I-labeled Con A for 20 min at 37°C. Triton X-100 was added at a final concentration of 2% (wt/vol), the platelets were centrifuged, and pellets and supernatant fractions were subjected to SDS PAGE. The radioactivity in GPIIb $\alpha$  (■), GPIII (□), and <sup>125</sup>I-labeled Con A (●) was determined in excised bands at  $M_r$  = 123,000, 105,000, and 25,000, respectively.

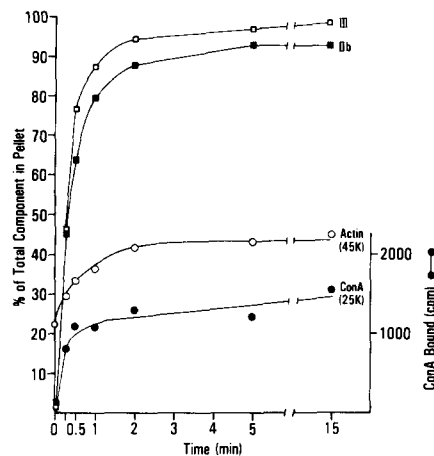

FIGURE 3 Kinetics of the Con A-induced cosedimentation of platelet surface-labeled glycoproteins with the Triton-insoluble residue. This experiment was performed as described in the legend for Fig. 2, except that <sup>125</sup>I-labeled Con A was added at a final constant concentration of 100  $\mu$ g/ml. The reaction was stopped at each indicated time point by adding Triton X-100. The "zero" time point was obtained by adding <sup>125</sup>I-labeled Con A to a Triton X-100 lysate of <sup>125</sup>I-labeled resting platelets (compare with Fig. 2, no Con A). Note that the increase in sedimentability of GPIIb (as  $\alpha$  chain) (■), GPIII (□), <sup>125</sup>I-labeled Con A (●), and actin (○) increased with time and was maximal by 30–60 s after Con A addition.

### The Effect of DNase I on the Con A-induced Association of GPIIb and III with the Triton-insoluble Residue

We considered the possibility that Con A might be merely precipitating the Triton-solubilized glycoproteins. To test this possibility and to determine whether the cosedimentation of GPIIb and III with the actin-containing Triton insoluble residue was the result of interactions between the two, we tested the effect of DNase I, an actin-depolymerizing agent (14, 15, 18), on the sedimentability of the various components in Con

A-activated cells. As shown in Fig. 4, when increasing concentrations of DNase I were added to Triton lysates for 30 min at 37°C before centrifugation, a progressive decrease in sedimentable actin was seen which approached levels of about ~10% of total. Thus the DNase I appeared to depolymerize actin by this criterion. A DNase-dependent decrease in GPIIb and III associated with the Triton residue was also seen. The released GPIIb and III were quantitatively recovered in the Triton supernatant. Thus, depolymerization of F-actin led to a release of GPIIb and III into the supernatant fraction.

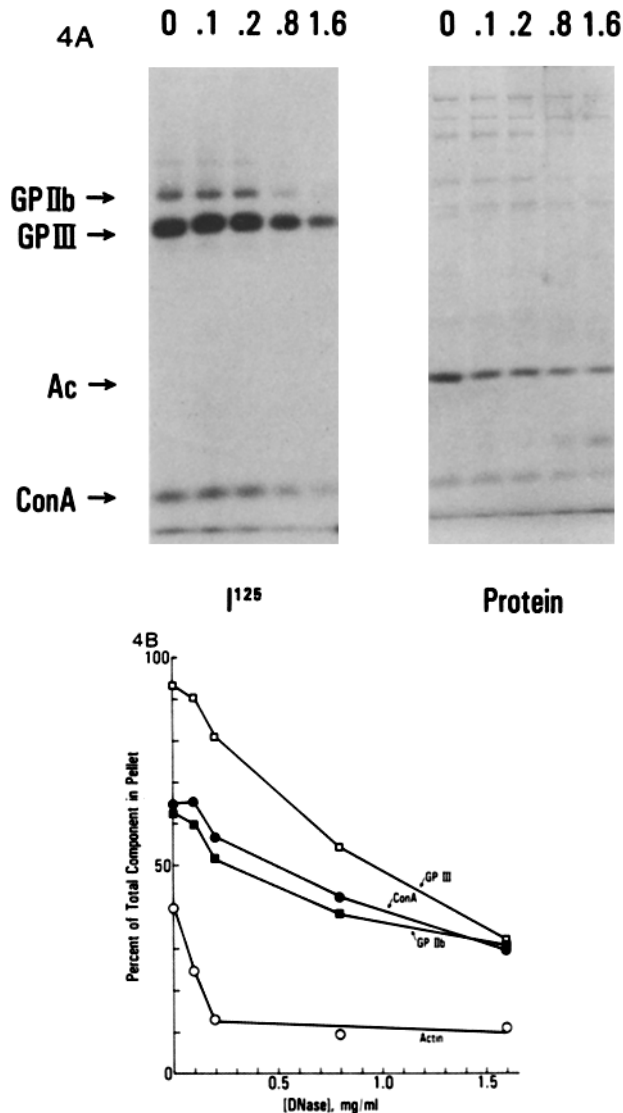

FIGURE 4 Effect of DNase I treatment of Triton X-100 extracts of  $^{125}\text{I}$ -Con A-stimulated surface-labeled platelets on cosedimentation of surface glycoproteins with the Triton-insoluble residue. A shows an autoradiogram of an SDS acrylamide gradient gel. In this experiment  $^{125}\text{I}$ -labeled platelets were exposed to  $^{125}\text{I}$ -labeled Con A and extracted with Triton (for 30 min at 37°C containing DNase I at the final concentration (mg/ml) indicated by the numbers above each lane. As can be seen in A, the amount of each  $^{125}\text{I}$ -labeled component associated with the pellet fractions decreases with increasing concentrations of DNase I added to the Triton extracts before centrifugation. Coomassie Blue-stained gels show a similar decrease in the amount of actin (45,000) associated with the Triton residue. Quantitative data obtained from averaging results of two such experiments are shown in B. DNase I treatment caused a dose-dependent decrease in both actin (○), GPIIb $\alpha$  (■), GPIII (□), and bound  $^{125}\text{I}$ -labeled Con A (●).

In addition to the above data, we found that addition of Con A (100  $\mu\text{g}/\text{ml}$ ) either to Triton lysates of whole  $^{125}\text{I}$ -platelets or to Triton supernatant fractions of unstimulated or thrombin-stimulated  $^{125}\text{I}$ -platelets did not result in precipitation of GPIIb and III after centrifugation (data not shown, but note "zero" time-point in Fig. 3 which was obtained by adding Con A to a Triton lysate of  $^{125}\text{I}$ -labeled resting platelets).

Inhibition of GPIIb and III sedimentability by DNase I in Triton lysates of Con A-treated platelets suggested a direct physical association between elements of the cytoskeleton and these surface glycoproteins. However, it was conceivable that DNase I exerted its effect by merely interfering with the interaction between Con A and the glycoproteins. To evaluate this possibility, the effect of DNase I on the binding of GPIIb and III to Con A was assessed by measuring the amount of each protein bound to Con A-Sepharose 4B in the presence and absence of 2 mg of DNase I added per ml of Triton extract. As seen in the upper panel of Fig. 5, DNase I had little effect on the amount of either GPIIb or III bound to Con A-Sepharose. In contrast, parallel experiments showed that the same amount of DNase I drastically reduced the amount of GPIIb and III recovered in the actin-containing pellet after centrifugation of Triton lysates of Con A-treated platelets (Fig. 5, top).

#### Ultrastructural Localization of Con A Bound to Isolated Triton Residues on Negatively Stained Ultrathin Frozen Sections

The previous data suggested a Con A-induced association between Triton residues and GPIIb and III. To investigate the spatial relationship between the Triton-insoluble Con A (and by inference GPIIb and III) and other Triton-insoluble structures, ultrastructural localization was carried out. For this

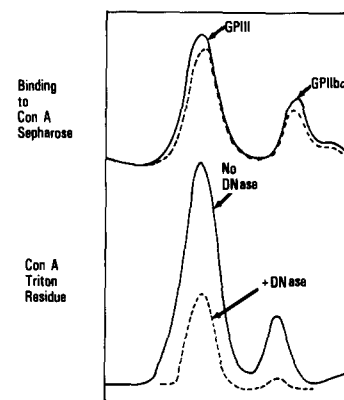

FIGURE 5 The effect of DNase I on the binding of GPIIb $\alpha$  and III to Con A-Sepharose 4B. (Top) Densitometer traces of an autoradiogram show the relative amounts of GPIIb (as  $\alpha$  chain) and III which were bound to Con A-Sepharose (150- $\mu\text{l}$  packed bed) after incubation of 100  $\mu\text{l}$  of a Triton extract of  $1 \times 10^8$  resting  $^{125}\text{I}$ -labeled platelets with (---) or without (—) added DNase I (2 mg/ml final). DNase I under these conditions produced <7% inhibition of the binding of either glycoprotein to Con A-Sepharose 4B. (Bottom) The inhibitory effect of DNase I (2 mg/ml) on the cosedimentation of GPIIb $\alpha$  and III with the high-speed Triton residue after incubation of the cells with Con A as described in Fig. 1. Under these conditions, DNase produced a 70% inhibition of glycoprotein sedimentability. This experiment was performed using an aliquot of the same labeled cells ( $1 \times 10^8$ ) as in the upper traces, except that  $9 \times 10^8$  unlabeled cells were added before Con A treatment, so that a visible, compact pellet was obtained.

purpose,  $^{125}\text{I}$ -surface-labeled platelets were treated with B-Con A ( $50\ \mu\text{g}/\text{ml}$ ) for 3 min at  $37^\circ\text{C}$ , lysed with Triton-EDTA, and residues were isolated by centrifugation. Parallel experiments showed that B-Con A was as effective as underivatized Con A with respect to inducing cosedimentation of GPIIb and III with the Triton residue (not shown). The pellets were fixed with 2% formaldehyde/0.5% glutaraldehyde, and ultrathin frozen sections were stained with avidin- $\text{Au}_{16\text{nm}}$  conjugate as described

in Materials and Methods. Fig. 6A-C shows typical stained thin sections of these Triton residues.

Gold colloid-avidin label was associated with the peripheral edges of  $3\text{-}\mu\text{m}$  organized filamentous structures. In sections where the uranyl acetate negative stain was heavier (Fig. 6B and C), a network of filamentous structures ( $\sim 60\text{-}70\ \text{\AA}$ ) was seen. Occasionally, a more discoid profile was observed (Fig. 6C) which was peripherally labeled as well.

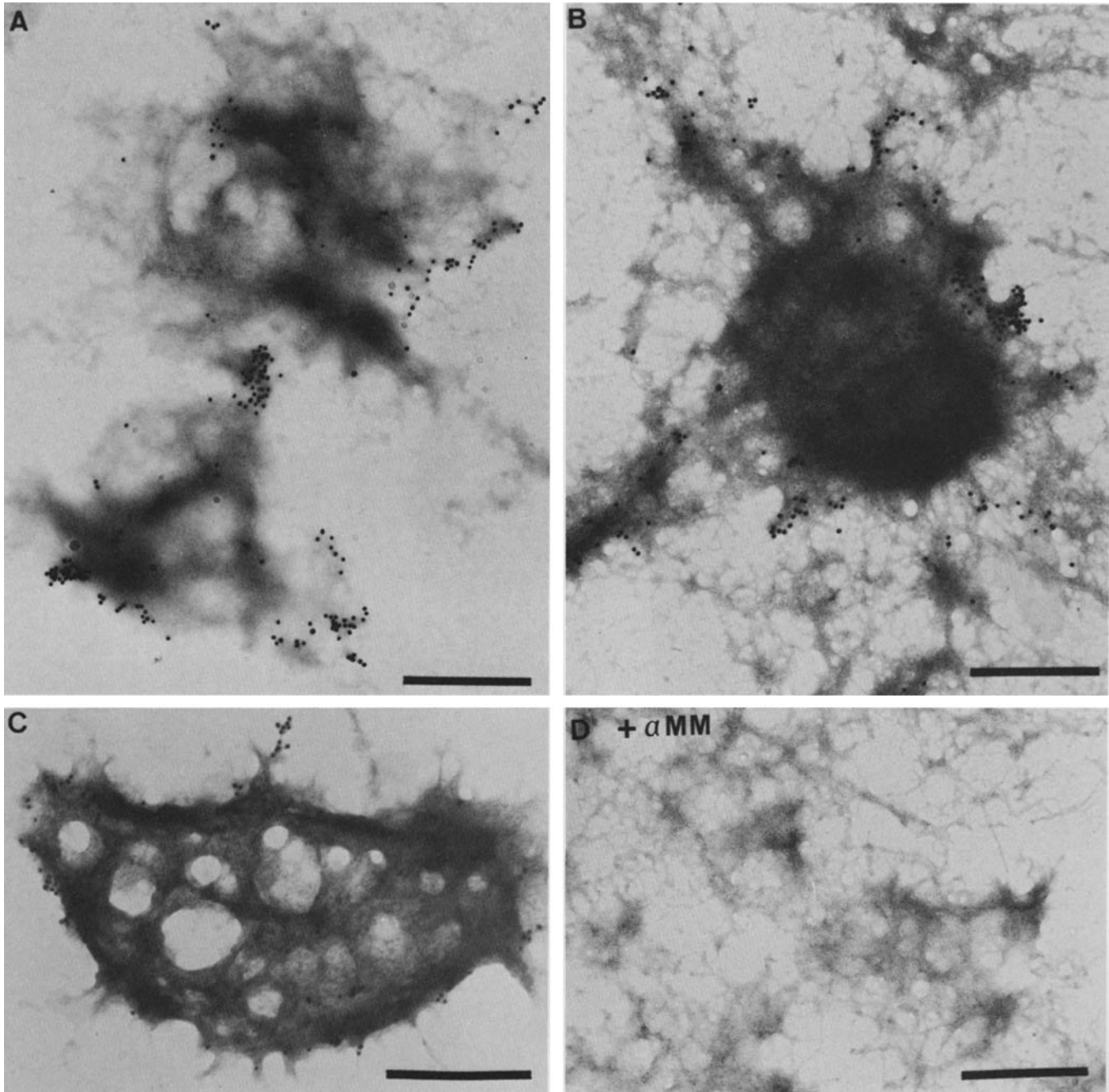

FIGURE 6 Ultrastructural localization of biotinyl-Con A on frozen thin sections of Triton residues of platelets pretreated with biotinyl-Con A. A-C show frozen thin sections of Triton pellets obtained by centrifugation after treating the intact platelets with biotinyl-Con A ( $50\ \mu\text{g}/\text{ml}$ ) for 3 min at  $37^\circ\text{C}$  before Triton lysis. The sections were prepared and stained on grids with a gold-avidin colloid (16 nm) conjugate, washed, and negatively stained as detailed in Materials and Methods. Note that the gold-avidin particles are localized primarily along the peripheral edges of cell-sized ( $\sim 3\ \mu\text{m}$ ) filamentous structures with a more electron-dense central region (A and B). In rare cases, more discoid profiles were seen which were also peripherally labeled with gold-avidin particles (C). D shows a sectioned pellet of platelets prepared as described above, except that  $\alpha$  methyl-D-mannose (50 mM) was present before addition of biotinyl-Con A. No appreciable labeling of the sections with gold-avidin was seen. In addition, the Triton pellets were composed of unorganized filaments typical of resting platelet Triton residues (20, 29). Bars,  $1\ \mu\text{m}$ .

When 50 mM  $\alpha$ -methyl-D-mannose was included in the incubation medium before B-Con A addition, no appreciable labeling of thin sections of the Triton residue by avidin-gold was observed (Fig. 6D), a result which indicates the absence of B-Con A in these Triton residues. In addition, filamentous structures were not organized into individual cell-sized masses as seen with B-Con A in the absence of  $\alpha$ -methyl-D-mannose. Instead, relatively disorganized masses of filaments were seen similar to those reported by others (20, 29) for Triton residues of unstimulated platelets.

### Immunofluorescent Localization of Con A and Myosin in Thrombin-stimulated Platelets

The previous data suggested that Con A induced a linkage of surface glycoproteins to the platelet Triton-insoluble structures. To further explore the question of whether this occurred in intact cells or after Triton lysis, immunofluorescent localization of Con A and a Triton-insoluble component myosin in intact platelets was performed. As shown in Fig. 7 (left-hand micrographs), when thrombin-stimulated platelets were fixed and then stained with fluorescein-labeled Con A (Fl-Con A) the fluorescence was distributed in a diffuse pattern over the entire cell surface. In contrast, if the cells were treated with thrombin in the presence of Fl-Con A and then fixed, the fluorescence was concentrated over the central region of the cells, as shown in Fig. 7 (right-hand micrographs).

Pollard et al. (30, 31) have previously shown that the initially uniform myosin distribution becomes centralized in stimulated platelets, in a pattern that is reminiscent of that seen for Con A in the right-hand micrographs of Fig. 7. To determine the distribution of myosin in cells treated with Fl-Con A and thrombin before fixation, such cells were made permeable with 0.1% Triton after fixation and stained for myosin using goat anti-uterine myosin antibodies followed by a rhodamine-labeled rabbit anti-goat IgG F(ab')<sub>2</sub>. As shown by the upper micrographs in Fig. 8, the centralized zone of Con A staining is coincident with the myosin staining pattern. This pattern is not due to shape changes per se since the observed centralization of myosin and Fl-Con A (Fig. 8, lower micrographs) induced by Fl-Con A and thrombin occurred even after inhibition of shape change with cytochalasin B.

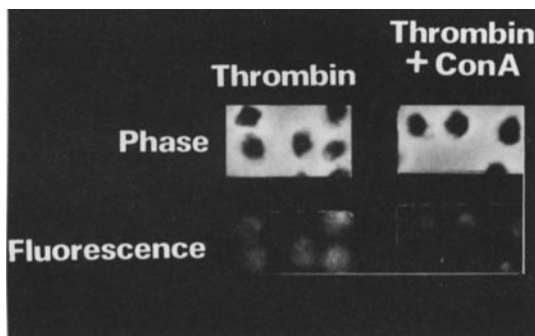

FIGURE 7 Immunofluorescent localization of surface-bound Fl-Con A in thrombin-stimulated platelets. In the left panels, phase-contrast and fluorescence micrographs are shown of thrombin-stimulated platelets stained with Fl-Con A after fixation with 2% paraformaldehyde. Note the diffuse, patchy fluorescence. Right panels show phase-contrast and fluorescence micrographs of platelets stimulated with thrombin (0.5 U/ml) and Fl-Con A (100  $\mu$ g/ml) for 10 min and then fixed with paraformaldehyde. Note, in contrast to the left panels, that the fluorescence is centralized and is no longer uniformly distributed over the entire cell. Bar, 5  $\mu$ m.

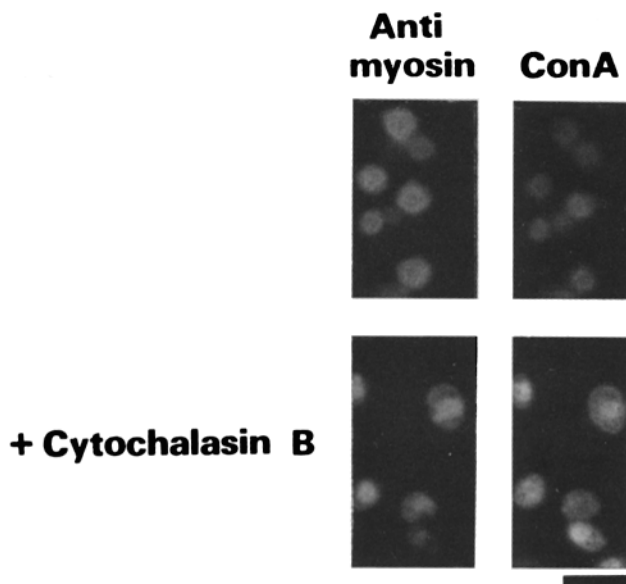

FIGURE 8 Immunofluorescent localization of myosin and Fl-Con A in platelets stimulated with Fl-Con A and thrombin for 10 min at 37°C in the presence (lower panels) and absence (upper panels) of cytochalasin B. Note the centralized ringlike zone of Fl-Con A staining which is similar to that seen in Fig. 6 in cells treated with Fl-Con A and thrombin before fixation. The Fl-Con A staining patterns are coincident with the myosin staining patterns in both the presence and absence of cytochalasin B, even though platelet shape remained essentially discoid in the presence of the drug. Although not shown, the myosin distribution in resting platelets was uniform and only assumed the illustrated centralized ring pattern in thrombin-activated cells. Bar, 5  $\mu$ m.

### DISCUSSION

The results obtained here, together with other data discussed below, indicate that Con A induces a dose-dependent and rapid physical association of specific surface glycoproteins with the internal cytoskeleton. In the case of Con A-stimulated cells, we have found that these interactions require intact cells and can not be induced by addition of Con A to detergent extracts of resting or thrombin-stimulated platelets. Furthermore, we have found that GPIIb and III are released from the Triton residue under conditions (i.e., addition of DNase I) which decrease the sedimentability of platelet actin. DNase I appears to exert this effect directly upon platelet actin since both GPIIb and III were isolated from Triton extracts of Con A-treated platelets using Con A-Sepharose 4B in similar quantities in the presence or absence of DNase I. In addition, localization of bound Con A in thin frozen sections of isolated Triton residues showed that it was associated with peripheral regions of organized filamentous structures (Fig. 6). Finally, double-label immunofluorescent localization studies showed that under conditions which induced a redistribution (i.e., a centralization) of platelet myosin, surface-associated Con A was similarly redistributed in a way which appears analogous to the capping process seen in other cell types (1, 2, 5, 6, 32).

The rationale of the approach we have taken is based on the observation by both Nachmias (20) and Phillips et al. (29) that intact platelet cytoskeletons can be isolated from Triton lysates of activated platelets. Light microscopic examination of Triton extracts of Con A-treated platelets showed structures which superficially resembled intact cells, but electron microscopic

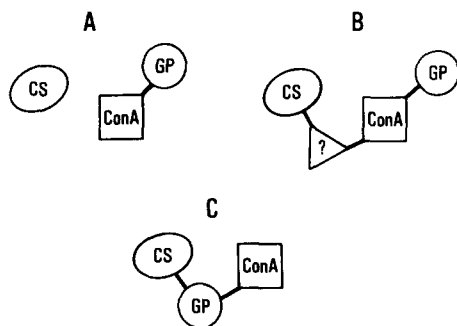

FIGURE 9 Three schematic models which could explain Con A-induced cosedimentation of platelet surface glycoproteins (GP) with the cytoskeleton (CS). A represents fortuitous cosedimentation of GP with CS in the absence of a physical linkage; B and C represent models in which Con A is presumed to induce a physical linkage of GPIIb and III (GP) to the cytoskeleton either indirectly through a hypothetical nonradioactive, Con A-binding surface protein ( $\Delta$ ) (B) or by a direct transmembrane linkage (C).

examination revealed that they consisted of a complex array of filamentous material similar to that reported by Nachmias and Phillips et al. (20, 29) for glass-activated and thrombin-activated platelets, respectively.

Three possible explanations for the cosedimentation of glycoproteins with the platelet cytoskeleton in the presence of Con A are depicted in Fig. 9. These are: (A) fortuitous cosedimentation of glycoprotein-Con A aggregates with the cytoskeleton, (B) Con A bridging of  $^{125}\text{I}$ -labeled glycoproteins to the cytoskeleton via a hypothetical, nonradioactive Con A-binding surface glycoprotein, or (C) Con A induction of a direct transmembrane interaction between GPIIb and III and the internal cytoskeleton. Fortuitous cosedimentation (A) appears to be ruled out by a number of observations. First, addition of Con A to Triton lysates of unstimulated or thrombin-stimulated platelets did not precipitate the solubilized glycoproteins. This result also rules out nonspecific binding of glycoproteins to the exposed cytoskeleton in the presence of Con A as an explanation of our results. Secondly, the Triton-insoluble Con A was associated with the periphery of organized filamentous structures whose size and morphology (Fig. 6) support their identification as platelet cytoskeletons (20, 29). Thirdly, disruption of the actin-containing cytoskeleton by DNase I (14, 15, 17) led to solubilization of GPIIb and III along with the solubilization of actin (Fig. 4). This effect is clearly not due to DNase I inhibition of glycoprotein-Con A interactions per se and supports the notion that DNase I acts by depolymerizing the mass of actin filaments which appear to form the bulk cell cytoskeleton rather than by disrupting the linkage of Con A to the glycoproteins.

It appears that considerable actin must be solubilized before GPIIb and III are solubilized (Fig. 4B). This suggests that solubilization of GPIIb and III occurs when portions of the cytoskeleton are sufficiently fragmented to prevent their sedimentation. Thus, DNase-solubilized GPIIb and III might then exist as a complex associated with cytoskeletal fragments. In support of this, preliminary experiments have indicated that DNase-solubilized GPIIb and III comigrate with Con A, small quantities of actin, and other unidentified proteins, and sediment more rapidly in gradient ultracentrifugation experiments than solubilized uncomplexed glycoproteins (R. G. Painter and M. H. Ginsberg, unpublished observations).

On the basis of the above discussion, explanation A appears

excluded, and a physical interaction of the glycoproteins with the cytoskeleton is likely. Moreover, this interaction appears to occur in the intact cell, since coredistribution of bound FI-Con A with platelet myosin was observed in thrombin-stimulated cells. The interaction of these membrane glycoproteins with the cytoskeleton could occur via Con A bridging the glycoproteins to an unlabeled surface protein which is bound to the cytoskeleton (model B). Alternatively, the Con A could induce direct interaction of the glycoproteins with the cytoskeleton (model C). At present, we favor model C over the more indirect model B, on the basis of our preliminary evidence which shows that  $\text{F}(\text{ab}')_2$  fragments of antibodies directed against GPIIb and III induce cosedimentation of these glycoproteins with the Triton residue (Ginsberg, M. H., and R. G. Painter, manuscript in preparation). These results argue against model B since the specific antibody presumably cannot bridge the surface glycoprotein to a different unlabeled surface protein through its antigen-binding sites.

Using techniques similar to those used here, Phillips et al. (30) found that when human platelets are treated with thrombin, under conditions which favor aggregation, GPIIb and III become associated with the Triton residue. These workers concluded that these two surface proteins were thus involved in platelet aggregation. Both we and Phillips et al. observed that under nonaggregating conditions thrombin did not induce associations between GPIIb and III and the Triton residue. We could find no evidence for significant agglutination of our unstirred platelets with either Con A or thrombin by light or electron microscopic examination of these preparations. Thus, the induction of surface glycoprotein-cytoskeletal interactions by Con A reported here are probably not due to platelet aggregation by the lectin. A likely explanation of these results is that a multivalent ligand, such as Con A, cross-links surface glycoproteins on the cell surface and that it is this cross-linking step that is crucial for subsequent association of these components with the cytoskeleton. Thus, in the case of platelet aggregation induced by thrombin under stirred conditions, divalent cation-dependent cell-cell interactions may serve to cross-link GPIIb and III, thereby inducing their linkage to the cytoskeleton after platelet aggregation has occurred.

The requirement for clustering of surface molecules for activation of cellular function is a hallmark of a number of cellular processes. In B lymphocytes, for example, clustering of surface Ig molecules by bivalent antibody (but not Fab fragments) induces capping and endocytosis of such molecules in a process that appears to involve an induction of cytoskeletal interactions reminiscent of those seen in the platelet (1, 2, 5, 6, 9, 32).  $\alpha$ -Actinin, F-actin, and myosin have been demonstrated at increased levels in the region of caps by immunofluorescence techniques (1, 2, 9, 32). Furthermore, apparent biochemical association between F-actin and surface Ig has been demonstrated in lymphocytes capped by anti-Ig antibodies but was not demonstrable when Fab fragments were bound to the cells (6). In addition, Condeelis (5) found actin and myosin, by biochemical and morphologic criteria, in Con A "caps" isolated from *Dictyostelium discoideum* amoeba. The immunofluorescent localization studies reported here are somewhat analogous to capping. Thus, we found that platelet myosin codistributed with surface bound Con A in thrombin-stimulated platelets. This was true only if FI-Con A was present at the time of thrombin stimulation; adding FI-Con A to thrombin stimulated cells which had been fixed yielded a diffuse pattern of surface FI-Con A staining which was clearly different from the myosin staining pattern (Fig. 8). These results together with



the biochemical (Fig. 1) and ultrastructural results (Fig. 6) suggest that Con A is sufficient to induce an association of membrane proteins with the cytoskeleton but that their subsequent major redistribution requires thrombin-stimulated cytoskeletal centralization.

We do not as yet understand the molecular mechanisms involved in forming the complex between GPIIb and III and the cytoskeleton. In view of the evidence which exists implicating these two proteins in platelet aggregation (28, 29), their linkage to the platelet contractile apparatus would be a reasonable mechanism for mediation of platelet functions such as clot retraction, assuming that an appropriate second signal such as thrombin exists. In any event, this system provides an excellent model in which to analyze the molecular interactions involved using conventional biochemical approaches.

The authors express their thanks to Kathy Gillam for her expert technical help and to Monica Bartlett for typing the manuscript. We would also like to thank Dr. Charles Cochrane for his valuable comments concerning the work and the completed manuscript.

This work was supported in part by U. S. Public Health Service National Institutes of Health (NIH) grants AI07007, AM27214, and HL-16411. Dr. Painter and Dr. Ginsberg are the recipients of NIH Career Development Awards AM0437 and AM0720, respectively.

This is publication 2374 from the Research Institute of Scripps Clinic. Reprint requests should be addressed to Dr. Painter.

Received for publication 28 January 1981, and in revised form 17 August 1981.

## REFERENCES

- Berlin, R. D., and J. M. Oliver. 1978. Analogous ultrastructure and surface properties during capping and phagocytosis in leukocytes. *J. Cell Biol.* 77:789-804.
- Bourguignon, L. Y. W., and S. J. Singer. 1977. Transmembrane interactions and mechanism of capping of surface receptors by their specific ligands. *Proc. Natl. Acad. Sci. U. S. A.* 74:5031-5035.
- Carlsson, L., F. Markey, I. Blikstad, T. Persson, and U. Lindberg. 1979. Reorganization of actin in platelets stimulated by thrombin as measured by DNase I inhibition assay. *Proc. Natl. Acad. Sci. U. S. A.* 76:6376-6380.
- Clemetson, K. J., A. Capitanio, and E. F. Luscher. 1979. High resolution two-dimensional gel electrophoresis of the proteins and glycoproteins of human blood platelets and platelet membranes. *Biochim. Biophys. Acta.* 553:11-24.
- Condeelis, J. S. 1979. Isolation of Con A caps during various stages of formation and their association with actin and myosin. *J. Cell Biol.* 80:751-758.
- Flanagan, J., and G. L. E. Koch. 1978. Cross-linked surface Ig attaches to actin. *Nature (Lond.)* 273:278-281.
- Frens, G. 1973. Controlled nucleation for the regulation of the particle size in monodisperse gold suspensions. *Nature (Lond.)* 241:20-22.
- Gartner, T. K., D. C. Williams, F. C. Minion, and D. R. Phillips. 1978. Thrombin-induced platelet aggregation is mediated by a platelet plasma membrane-bound lectin. *Science (Wash. D. C.)* 200:1281-83.
- Geiger, B., and S. J. Singer. 1979. The participation of  $\alpha$ -actinin in the capping of cell membrane components. *Cell.* 16:213-222.
- Ginsberg, M. H., and P. M. Henson. 1978. Enhancement of platelet response to immune complement IgG aggregates by lipid A-rich bacterial lipopolysaccharides. *J. Exp. Med.* 147:207-218.
- Ginsberg, M. H., G. Reiss, B. Jaques, and R. G. Painter. 1980. Co-distribution of GPIIb and III with myosin in thrombin-stimulated platelets. *Circulation.* 62(Suppl. 3):1318 (Abstr.).
- Ginsberg, M. H., L. Taylor, and R. G. Painter. 1980. The mechanism of thrombin-induced platelet factor 4 secretion. *Blood.* 55:661-688.
- Heggeness, M. H., and J. F. Ash. 1977. Use of the avidin-biotin complex for the localization of actin and myosin with fluorescence microscopy. *J. Cell Biol.* 73:783-788.
- Hitchcock, S. E. 1976. Depolymerization of F-actin by deoxyribonuclease I. *Cell.* 7:531-542.
- Hitchcock, S. E. 1980. Actin-deoxyribonuclease I interaction-depolymerization and nucleotide exchange. *J. Biol. Chem.* 255:5668-5673.
- Laemmli, U. K. 1970. Cleavage of structural proteins during assembly of the head of bacteriophage T4. *Nature (Lond.)* 227:680-685.
- Lazarides, E., and U. Lindberg. 1974. Actin is the naturally occurring inhibitor of deoxyribonuclease I. *Proc. Natl. Acad. Sci. U. S. A.* 71:4742-4746.
- Mannherz, H. G., J. Barrington-Leigh, R. Leberman, and H. Pfrang. 1975. A specific 1:1 G-actin: DNase I complex formed by the action of DNase I on F-actin. *FEBS Lett. (Fed. Eur. Biochem. Soc.)* 60:34-38.
- McGregor, J. L., K. J. Clemetson, E. James, T. Greenland, and M. Dechavanne. 1979. Identification of human platelet glycoproteins in SDS polyacrylamide gels using <sup>125</sup>I-labeled lectins. *Thromb. Res.* 16:825-31.
- Nachmias, V. T. 1980. Cytoskeleton of human platelets at rest and after spreading. *J. Cell Biol.* 86:795-802.
- Nicolson, G. L., and R. G. Painter. 1973. Anionic sites of human erythrocyte membranes. II. Antispectrin-induced transmembrane aggregation of the binding sites for positively charged colloidal particles. *J. Cell Biol.* 59:395-406.
- Okumura, T., M. Hasitz, and G. A. Jamieson. 1978. Platelet glycolactin. Interaction with thrombin and role as thrombin receptor of the platelet surface. *J. Biol. Chem.* 253:3435-3443.
- Painter, R. G., and A. T. McIntosh. 1979. The regional association of actin and myosin with sites of particle phagocytosis. *J. Supramol. Struct.* 12:369-384.
- Painter, R. G., K. T. Tokuyasu, and S. J. Singer. 1973. Immunoferritin localization of intracellular antigens: the use of ultracytometry to obtain ultrathin sections suitable for direct immunoferritin staining. *Proc. Natl. Acad. Sci. U. S. A.* 70:1649-1653.
- Painter, R. G., J. W. Whisenand, and A. T. McIntosh. 1981. The effect of cytochalasin B on actin and myosin assembly at particle binding sites in mouse macrophages: implications with regard to the mechanism of action of the cytochalasins. *J. Cell Biol.* 91:373-384.
- Phillips, D. R. 1972. Effects of trypsin on the exposed polypeptides and glycoproteins in the human platelet membrane. *Biochemistry.* 11:4582-4588.
- Phillips, D. R., and P. P. Agin. 1977. Platelet plasma membrane glycoprotein. Evidence for the presence of non equivalent disulfide bonds using nonreduced-reduced two-dimensional gel electrophoresis. *J. Biol. Chem.* 252:2121-2126.
- Phillips, D. R., and P. P. Agin. 1977. Platelet membrane defects in Glanzmann's thrombasthenia. Evidence for decreased amounts of two major glycoproteins. *J. Clin. Invest.* 60:535-545.
- Phillips, D. R., L. K. Jennings, and H. H. Edwards. 1980. Identification of membrane proteins mediating the interaction of human platelets. *J. Cell Biol.* 86:77-86.
- Pollard, T. D., K. Fujiwara, R. Handin, and G. Weiss. 1977. Contractile proteins in platelet activation and contraction. *Ann. N. Y. Acad. Sci.* 283:218-236.
- Pollard, T. D., S. M. Thomas, and R. Niederman. 1974. Human platelet myosin. I. Purification by a rapid method applicable to other non-muscle cells. *Anal. Biochem.* 60:258-66.
- Schreiner, G. F., K. Fukuiwara, T. D. Pollard, and E. R. Unanue. 1977. Redistribution of myosin accompanying capping of surface Ig. *J. Exp. Med.* 145:1393-1398.
- Spudich, J. A., and S. Watt. 1971. The regulation of rabbit skeletal muscle contraction. I. Biochemical studies of the interaction of the tropomyosin-troponin complex with actin and the proteolytic fragments of myosin. *J. Biol. Chem.* 246:4866-4971.
- Tangen, O., H. J. Berman, and P. Marfey. 1971. Gel filtration—a new technique for separation of blood platelets from plasma. *Thromb. Diath. Haemorrh.* 25:268-78.
- Tokuyasu, K. T. 1978. A study of positive staining of ultrathin frozen sections. *J. Ultrastruct. Res.* 63:287-307.
- Wallach, D., P. J. A. Davies, and I. Pastan. 1978. Purification of mammalian filamin. Similarity to high molecular weight actin-binding protein in macrophages, platelets, fibroblasts and other tissues. *J. Biol. Chem.* 253:3328-35.