

LAR Tyrosine Phosphatase Receptor: Alternative Splicing is Preferential to the Nervous System, Coordinated with Cell Growth and Generates Novel Isoforms Containing Extensive CAG Repeats

Julie S. Zhang and Frank M. Longo

Department of Neurology, University of California at San Francisco/Veterans Administration Medical Center, San Francisco, California 94121

Abstract. Receptor-linked tyrosine phosphatases regulate cell growth by dephosphorylating proteins involved in tyrosine kinase signal transduction. The leukocyte common antigen-related (LAR) tyrosine phosphatase receptor has sequence similarity to the neural cell adhesion molecule N-CAM and is located in a chromosomal region (1p32-33) frequently altered in neuroectodermal tumors. To understand the function of receptor-linked tyrosine phosphatases in neural development, we sought to identify LAR isoforms preferentially expressed in the nervous system and cellular processes regulating LAR alternative splicing.

We report here the isolation of a series of rat LAR cDNA clones arising from complex combinatorial alternative splicing, not previously demonstrated for the tyrosine phosphatase receptor gene family in general. Isoforms included: (a) deletions of the fourth, sixth and seventh fibronectin type III-like domains; (b) an alternatively spliced novel cassette exon in the fifth fibronectin type III-like domain; (c) two alternatively spliced novel cassette exons in the juxtamembrane region; (d) a retained intron in the extracellular region

with in-frame stop codons predicting a secreted LAR isoform; and (e) an LAR transcript including an alternative 3' untranslated region containing multiple stretches of tandem CAG repeats up to 21 repeats in length. This number of repeats was in the range found in normal alleles of genes in which expansions of repeats are associated with neurodegenerative disease and the genetic phenomenon of anticipation. RT-PCR and Northern analysis demonstrated that LAR alternative splicing occurred preferentially in neuromuscular tissue in vivo and in neurons compared to astrocytes in vitro and was developmentally regulated. Alternative splicing was also regulated in PC12 cells by NGF, in 3T3 fibroblasts by cell confluence and in sciatic nerve and muscle subsequent to nerve transection. Western blot analysis demonstrated that alternatively spliced cassette exons result in the presence of corresponding amino acid segments of LAR protein in vivo. These studies suggest specialized functions of LAR isoforms in the nervous system and support our hypothesis that LAR-like tyrosine phosphatase receptors play a role in neural development and regeneration.

PROTEIN tyrosine phosphorylation is a basic mechanism controlling cell proliferation, differentiation and neurite outgrowth. Growth factors which regulate cell growth in the nervous system via tyrosine kinase receptors include fibroblast growth factor, epidermal growth factor, and the neurotrophins such as NGF, brain-derived growth factor, and neurotrophins-3 and -4 (Cross and Dexter, 1991; Chao, 1992; Ip et al., 1992). Abundant expression of non-receptor tyrosine kinases such as pp60^{c-src} and p59^{lck} in developing neurons and their enrichment in growth cone fractions suggests that non-receptor tyrosine kinases also modulate neuronal development and plasticity (Matten et

al., 1990; Igelzi et al., 1994). The discovery of receptor-linked protein tyrosine phosphatases (PTPs)¹ has led to the hypothesis that extracellular cues such as growth factors and cell surface molecules regulate cell growth by modulating activity of both tyrosine kinase and tyrosine phosphatase receptors. These receptors would interact directly or indirectly to ultimately determine the net effect of multiple growth or differentiating signals (Fischer et al., 1991; Walton and Dixon, 1993; Vogel et al., 1993; Penninger et al., 1993).

Address all correspondence to F. M. Longo, Department of Neurology V-127, VAMC, 4150 Clement Street, San Francisco, CA 94121. Ph.: (415) 750-2011. Fax: (415) 750-1343.

1. *Abbreviations used in this paper:* ANOVA, analysis of variance; FNIII, fibronectin type III; HPTP δ , human PTP δ ; KLH, keyhole limpet hemacyanin; LAR, leukocyte common antigen-related gene; MPTP δ , mouse PTP δ ; PD, postnatal day; PTP, protein tyrosine phosphatase; RT, reverse transcription; VASE, variably alternatively spliced exon.

Approximately 20 distinct transmembrane receptor-linked PTPs have been cloned (reviewed in Charbonneau and Tonks, 1992; Walton and Dixon, 1993). The human leukocyte common antigen-related (LAR) gene was the second identified member of the receptor-linked PTP gene family (Streuli et al., 1988). It consists of an extracellular region with three Ig-like and eight fibronectin type III-like (FNIII) domains and a cytoplasmic region containing two tyrosine phosphatase domains typical of receptor PTPs (see Fig. 1). Ig and FNIII domains are motifs characteristic of cell adhesion and extracellular matrix molecules (Reichardt and Tomaselli, 1991; Edelman and Crossin, 1991). Sequence analysis of LAR Ig and FNIII domains revealed significant sequence similarity to domains in the neural cell adhesion molecule N-CAM, a neuronal surface glycoprotein which mediates cell adhesion and neurite outgrowth by homophilic and heterophilic binding (Edelman and Crossin, 1991; Rutishauser, 1993; Doherty and Walsh, 1994). N-CAM and similar cell adhesion molecules modulating neurite outgrowth such as L1, TAG-1, and fasciculin II lack intrinsic kinase or phosphatase activity (Doherty and Walsh, 1994). LAR can therefore be viewed as a "hybrid" molecule potentially combining both cell adhesion and tyrosine phosphatase functions. This feature of LAR combined with observations in *Drosophila* that LAR is central nervous system specific and is present primarily along axons (Tian et al., 1991) and that mammalian LAR is expressed by neurons and regulated by development, NGF, and cell confluence (Longo, F. M., J. P. Barnes, and J. A. Martignetti. 1991. *Soc. Neurosci. Abstr.* 17:762; Longo et al., 1993), suggested that LAR constitutes a novel receptor prototype regulating neurite outgrowth and pathfinding during neural development.

Four additional mammalian receptor-linked PTP family members have been discovered also containing both Ig and FNIII extracellular domains. In most cases, little is known about their potential alternative splicing. Mouse PTP δ (MPTP δ : Mizuno et al., 1993; human analog [HPTP δ]: Krueger et al., 1990) is expressed in brain, kidney, and heart. The use of alternative transcription start sites produces isoforms with one or three Ig domains while potential alternative splicing generates transcripts with either four or eight FNIII domains. RPTP μ is expressed in brain, lung and heart and promotes homophilically mediated cell-cell adhesion of insect cells (Gebbinck et al., 1991, 1993; Brady-Kalnay et al., 1993). RPTP κ is expressed in a wide range of tissues including hippocampus, cortex, liver, kidney, and intestine and is developmentally regulated (Jiang et al., 1993). R-PTP- κ also promotes homophilically mediated cell-cell adhesion of insect cells (Jiang et al., 1993; Sap et al., 1994). PTP NE-3 (Walton et al., 1993), PTP-P1 (Pan et al., 1993), CPTP-1 (Sahin and Hockfield, 1993), and RPTP- σ (Yan et al., 1993) are the same receptor-linked PTP which is expressed as larger (~8 kb) and shorter (~6 kb) transcripts. The larger form has been detected in multiple tissues and cell lines including brain, heart, lung, testes, liver, and kidney. The shorter transcript is selectively expressed in neural tissue and cells including cortex, olfactory neuroepithelium and PC12 cells and is developmentally regulated. The mechanism by which the two transcripts are generated has not been directly determined but may involve alternative splicing. Pan et al. (1993) demonstrated by cDNA and genomic sequencing that intracellular alternative splicing generates a

4.8-kb isoform of PTP-P1 (PTP-PS) in which the second tyrosine phosphatase domain is absent.

The first-discovered receptor-linked PTP was leukocyte-specific CD45 (leukocyte common antigen) which in response to T cell receptor stimulation activates the Src family tyrosine kinases p56^{lck} and p59^{lyn} by dephosphorylating a site at their carboxyl terminus (Charbonneau et al., 1988; Penninger et al., 1993). Alternative splicing of extracellular domain CD45 exons generates distinct isoforms that are differentially associated with lymphocyte proliferation, maturation, activation, and life span (Michie et al., 1992; Penninger et al., 1993). Alternatively spliced CD45 isoforms also differentially interact with different ligands. For example, low molecular weight CD45 interacts with cell surface CD2 molecules while a larger CD45 isoform preferentially associates with the integrin receptor LFA-a (Schraven et al., 1990; Dianzani et al., 1992).

Previous Northern analysis of rat LAR expression in the nervous system from the single copy gene suggested that, like CD45, variant LAR mRNA transcripts are also produced (Longo et al., 1993). In this study we report that LAR transcripts are alternatively spliced and that splicing is regulated during development and by denervation, NGF-induced PC12 cell differentiation and cell confluence. We demonstrate a complex array of nervous system-preferential LAR extracellular and intracellular alternative splicing which includes deletions of specific FNIII domains and insertions of novel exons into extracellular and juxtamembrane regions. These forms of alternative splicing and these modes of splicing regulation have not previously been observed in the general family of receptor-linked PTP genes. Highly regulated combinatorial alternative splicing of cell adhesion and other motifs in LAR suggests a mechanism by which LAR, and other receptor-linked PTPs, may regulate neural development. These forms of PTP alternative splicing may represent a fundamental mechanism regulating neural development and regeneration. The peptide sequence and nomenclature of the first two novel LAR exons described here have been reported in abstract form (Zhang, J. S., and F. M. Longo. 1992. *Soc. Neurosci. Abstr.* 18:949a; Zhang, J. S., and F. M. Longo. 1993. *Soc. Neurosci. Abstr.* 19:1308a).

Materials and Methods

Nomenclature

Mammalian LAR cDNA clones reported thus far correspond to the ~8-kb human LAR transcript originally described by Streuli et al. (1988). Rat cDNA clones isolated from hypothalamus (Pot et al., 1991), fibroblast (Yu et al., 1992), whole brain (Longo et al. 1993), and muscle (Zhang and Goldstein, 1991) are rat analogs of the human ~8-kb isoform. Since the ~8-kb isoform is the common and predominant LAR form reported, we will refer to it as "constitutive" LAR. The isoforms predicted by the cDNA clones in this study containing insertions and deletions compared to ~8-kb human and rat LAR will be referred to as "alternative" isoforms.

Isolation and Sequencing of Rat LAR cDNA Clones

For each round of cDNA library screening, approximately 400,000 phagemid plaques were screened from one of the two following Lambda Zap II phagemid rat brain cDNA libraries (Stratagene Corp., La Jolla, CA): adult whole brain and adult hippocampus. Libraries were screened with ³²P-labeled oligonucleotide probes using the protocol and reagents recommended by Stratagene Corp. Positive clones were isolated according to the Stratagene protocol and nucleotide sequences were determined by the chain

termination method using single- and double-stranded DNA template with successive oligonucleotide primers (Sequenase 2.0 kit protocol and reagents from United States Biochemical Corp., Cleveland, OH). Regions with ambiguity were sequenced from the opposite direction and by using single-stranded template. Guanine and cytosine-rich regions were sequenced by Taq DNA polymerase and 7-deaza GTP on single-stranded DNA templates (GENE-ATAQ sequencing kit and protocol from Pharmacia LKB Biotechnology, Piscataway, NJ).

Cloning and Sequencing of Introns

High molecular weight DNA was isolated as described (Sambrook et al., 1989). In brief, adult Sprague-Dawley rat brain was homogenized in SDS lysis buffer followed by treatment with proteinase K at 65°C overnight with shaking (Sambrook et al., 1989). Lysis mixture was extracted by phenol/chloroform and DNA was isolated by ethanol precipitation. PCR was performed with 2 µg genomic DNA template and primers flanking putative splice junctions as described in the figure legends. PCR products were isolated from agarose gels by using glass milk (GeneClean kit; BIO 101, La Jolla, CA) or gelase enzyme (Epicentre Technologies Corp., Madison, WI), subcloned into the pCR vector (Invitrogen, San Diego, CA, manufacturer's reagents and protocol) and sequenced using successive oligonucleotide primers.

RNA Isolation from Tissues

Brain, spinal cord, heart, nerve, and muscle tissue was dissected from Sprague-Dawley rats at the ages indicated in figure legends, immediately frozen on dry ice powder and stored at -70°C. Poly(A) RNA was directly isolated from tissue and cultured cells by incubation of samples in tissue lysis buffer with oligo dT cellulose (type 3; Collaborative Research, Inc., Waltham, MA) using a standard protocol and reagents (FastTrack poly[A] RNA isolation kit; Invitrogen). To remove any contaminating DNA, poly(A) RNA was incubated with DNase (2 U in a total volume of 400 µl; Promega Biotec, Madison, WI) at 37°C for 30 min. The quality of each RNA preparation was assessed by fractionation through a denaturing agarose gel and staining in ethidium bromide. Poly (A) RNA from 9-wk-old Sprague-Dawley rat muscle, heart, lung, kidney, liver, and pancreas was purchased from Clontech (Palo Alto, CA).

RNA Isolation from Cultured Cells

Neurons were harvested from embryological day 18 rat cortex cultures treated with Ara C (Magal et al., 1991). Approximately 95% of these cells have neuronal morphological characteristics by phase microscopy following treatment with Ara C. Glial cultures from postnatal day (PD) 2 rat cortex cultures were enriched for astrocytes by differential attachment (Magal et al., 1991). Astrocytes were harvested at either 50% confluence or ~1 d after reaching 100% confluence. Cultured cells were rinsed in ice cold PBS, dislodged by incubation at room temperature in 0.08% trypsin in PBS, pelleted, and stored at -70°C.

PC12 cells (SPC12; Schubert et al., 1977) were grown in Dulbecco's modified Eagle's medium (with 3.7 g/l NaHCO₃, 4.5 g/l glucose, 0.584 g/l L-glutamine) containing 10% fetal bovine serum, 5% horse serum, and penicillin-streptomycin in untreated tissue culture flasks. Cells were propagated from a single T-75 flask by splitting 1:2 after they reached 40–60% confluence. Control PC12 cells were harvested when they reached ~60% confluence. In other flasks, when cells were ~40% confluent, differentiation was induced by changing to medium containing 2% fetal calf serum and 1% horse serum and adding β-NGF to a final concentration of 50 ng/ml. NGF was purified as described by Mobley et al. (1986) and kindly supplied by Dr. Mobley (University of California, San Francisco, CA). After 1 d in the presence of NGF, ~80% of the PC12 cells had processes approximately one cell diameter in length. After 3 d NGF-treated cultures were ~60% confluent and ~90% of the cells had processes two to five cell diameters in length. By 5 d, >90% of the cells had processes greater than five cell diameters in length. Cells were collected at 1, 3, and 5 d after adding NGF and stored at -70°C.

Swiss 3T3 fibroblasts (American Type Culture Collection, Rockville, MD) were grown in the above Dulbecco's modified Eagle's medium with 10% fetal bovine serum. One set of cells was harvested at 50% confluence and another approximately 1 d after reaching 100% confluence.

Northern Hybridization

Northern blot hybridization was carried out using standard protocols (Sambrook et al., 1989). Poly(A) RNA (2–4 µg) was electrophoresed through

a 1.3% agarose, 6.6% formaldehyde gel, and transferred overnight by capillary electrophoresis to a nylon membrane (Schleicher & Schuell, Keene, NH). Before and following transfer, gels were stained in ethidium bromide to assess RNA quality, degree of transfer, and location of RNA size markers (0.24–9.5 kb RNA ladder; GIBCO BRL, Gaithersburg, MD). To generate a probe corresponding to the LAR alternative 3' untranslated region, an ~0.9-kb AccI restriction fragment of pRLAR4.0 spanning from nucleotide 3098 of the insert (see Fig. 2 A, downstream from the CAG repeat region) to the AccI site in the vector multiple cloning site, was cloned into the AccI site of bluescript SK⁻ (pLARAccI). The orientation of the pLARAccI insert was confirmed by sequencing. pLARAccI was linearized upstream of the insert with DraII or XhoI enzymes and antisense riboprobe was generated using T3 RNA polymerase and UTP[α-³²P] (Promega Biotec reagents and transcription protocol). Oligonucleotide probes were end-labeled with ATP[γ-³²P] with T4 DNA polynucleotide kinase (Sambrook et al., 1989). Cyclophilin riboprobe was synthesized with SP6 RNA polymerase using rat cyclophilin clone pBI5 linearized with PstI (Danielson et al., 1988). When using riboprobe, blots were hybridized in buffer consisting of 5X SSPE, 5X Denhardt's, 50% formamide, 1% SDS, and 100 µg/ml salmon sperm DNA at 50°C overnight (Sambrook et al., 1989). After hybridization, blots were rinsed in 2X SSC/0.1% SDS three times for 5 min each at room temperature, treated with RNaseA (1 µg/ml; Promega Biotec) in 2X SSC for 5 min at room temperature, washed in 0.1X SSC/0.1% SDS at 50°C for 30 min, and then in 0.1X SSC/0.1% SDS at 65°C for 20 min. When using oligonucleotide probes, blots were hybridized in buffer consisting of 5X SSPE, 5X Denhardt's, 1% SDS, and 10% dextran sulfate at 50°C overnight and were then washed in 2X SSC, 1% SDS buffer at 50°C for 30 min and 0.1X SSC, 1% SDS at 55°C for 30 min. Blots were exposed to x-ray film for 15 to 60 min for cyclophilin detection and 1 to 4 d for LAR detection.

RT-PCR

First strand cDNA synthesis with poly(A) RNA and random hexamers and subsequent PCR were conducted using reagents and protocols included in the GeneAmp RNA PCR kit (Perkin Elmer Cetus, Norwalk, CT). PCR was performed for 30 cycles as follows: denaturing, 94°C 1 min; annealing, 57°C 1 min (68°C for primers flanking the CAG repeat region); extension, 72°C 2 min. Primers are described in figure legends. All reverse transcription (RT)-PCR and PCR reaction sets included the use of water in place of template in one or more reactions as a negative control. Positive controls consisted of the relevant plasmids indicated in figure legends. RT-PCR products were electrophoresed through 6% (10% for LASE-b) acrylamide gels, stained in ethidium bromide and photographed. Prominent and consistent bands of unexpected size were extracted from agarose gels, subcloned into PCR vector (Invitrogen) and sequenced as described above.

Quantitation of RT-PCR

The proportion of LAR transcripts with and without a given insert or deletion was estimated by methods established for competitive PCR, a technique used for quantitative PCR or RT-PCR (Wang et al., 1989; Gilliland et al., 1990; Foley et al., 1993). In competitive PCR or RT-PCR, templates differing by length (or other features such as restriction sites) but containing identical primer sites are coamplified in the same reaction. Since amplification efficiency is primarily determined by primer sequences, both templates are amplified with a similar efficiency, even beyond the exponential phase of the reaction. The relative amounts of final PCR product are therefore proportional to the starting proportions of the different templates. The proportionate quantities of each product can be readily determined by densitometric scanning of ethidium bromide-stained gels (Gilliland et al., 1990). Coamplification with one set of primers of mRNA/cDNA isoforms differing by the presence of an insertion or deletion has proved useful for accurately quantitating changing proportions of mRNA isoforms (Small and Akeson, 1990).

We used a similar strategy for measuring the change in proportions of LAR isoforms. For each set of LAR RT-PCR products, the volume of product loaded onto gels and the amount of ethidium bromide staining were adjusted so that the degree of band staining would be as close as possible to the mirage of band staining intensity. Band signals were quantitated by analyzing photograph negatives with a scanning densitometer. The proportion of LAR transcripts with and without a given insert or deletion was estimated by calculating the ratio of band signal derived from RT-PCR product with a given insert or deletion over that without the insert or deletion. Significant differences in G/C content or secondary structure due to inserts or deletions could theoretically cause differences in denaturation or polymerase processivity and might thereby lead to an under-estimation in the

absolute difference of starting proportions of templates (Foley et al., 1993). Therefore, our data analysis focused on detecting any changes in proportions of LAR isoforms (i.e., during development) with and without a given insert or deletion rather than determining absolute proportions of isoforms.

Southern Blot Hybridization of RT-PCR Products

PCR products derived with primers flanking LASE-b were electrophoresed in 10% acrylamide gels and transferred by nylon membranes (Hybond-N+; Amersham Corp., Arlington Heights, IL) by semidry electrotransfer. Membranes were hybridized with a ³²P-labeled 23 nucleotide antisense probe containing the 12 nucleotides corresponding to the LASE-b insert and the 11 nucleotides immediately downstream from LASE-b (Fig. 5). Hybridization was performed in a solution containing 1% SDS, 5X SSPE, 5X Denhardt's, and 10% dextran sulfate at 50°C overnight. Blots were washed in 2X SSC, 1.0% SDS for 5 min at room temperature and for 30 min at 50–55°C in the same solution. Filters were exposed to x-ray films 1 to 3 d at –70°C with an intensifying screen.

Generation of LASE-a and LASE-c Antisera

Peptides corresponding to LASE-a (GSSAPSCPNISS) and LASE-c (CAQWRPESEDYET) regions were synthesized and conjugated to KLH (keyhole limpet hemacyanin). Rabbits were immunized with conjugated peptide emulsified in Freund's complete adjuvant and boosting immunizations were emulsified in Freund's incomplete adjuvant. Rabbits were boosted at 3-wk intervals and sera collected prior to immunization and 11 d after each boost. Antibodies were purified by immunoaffinity purification using each of the above peptides coupled to a Sulfolink Gel (Immobilization Kit 2, reagents, and protocol; Pierce, Rockford, IL). Antibodies were eluted with 100 mM glycine, pH 2.5 (Harlow and Lane, 1988).

Western Blot Analysis

Western analysis was conducted using standard protocols (Harlow and Lane, 1988) and the Western Exposure Chemiluminescent Detection System (Clontech). Protein extract was prepared from newborn rat cerebellum. Tissue was homogenized in RIPA buffer for 30 min on ice, sonicated for 10 s, and centrifuged at 14,000 g for 20 min. The supernatant was collected and concentrated using a Centricon-30 filter. Approximately 20 µg of protein extract was electrophoresed through a 6% acrylamide gel and transferred to a nylon blot. LASE-a antiserum was also used to immunoprecipitate LAR from the above cerebellum extract. 100 µl of supernatant was incubated with either 2 µl of preimmune serum or 1 µl of postimmune LASE-a antiserum for 2 h at 4°C. Antigen-antibody complexes were isolated by incubation with protein A-linked agarose (Harlow and Lane, 1988), concentrated and electrophoresed. Immunoblots were incubated with either LASE-a preimmune serum, LASE-a postimmune serum, affinity-purified LASE-a antibodies or affinity-purified LASE-c antibodies.

Results

The Intracellular Domain of LAR Is Alternatively Spliced

To identify potential LAR isoforms, we screened an adult rat whole brain cDNA library for LAR cDNA clones using a 30 nucleotide probe (nt2501-2530; see Fig. 3 A) corresponding to a site within the first tyrosine phosphatase domain of rat LAR. Clone pRLAR4.0 contained a 4-kb insert with overlapping sequence identity to rat LAR starting ~45-bp downstream from the transmembrane domain and extending to a poly(A) tail (see Fig. 2). The sequence of pRLAR4.0 differed from that of constitutive rat LAR by two features. The first was the presence of a 33-bp insert (nt 80-112; see Fig. 2 A) in the juxtamembrane region, 121-bp downstream from the transmembrane domain and 135-bp upstream from the first tyrosine phosphatase domain. We name this insert LAR Alternatively Spliced Element-a (LASE-a). The LASE-a insert maintained the open reading frame and predicted the addition of eleven amino acids, SSAPSCP-

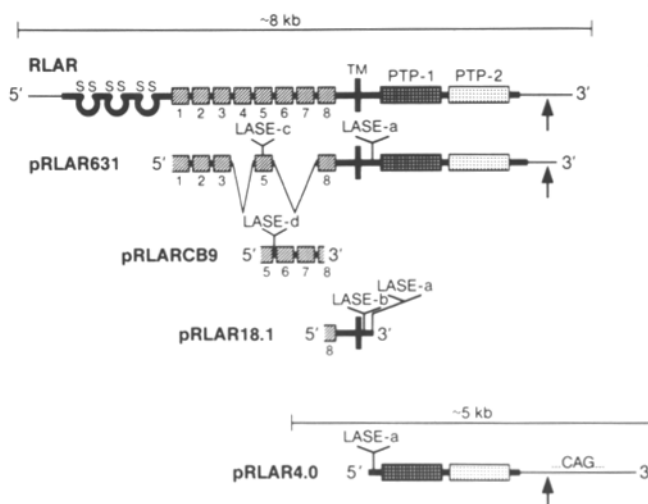

Figure 1. Schematic summary of alternative LAR cDNA clones. Constitutive rat LAR (*RLAR*) is encoded by an ~8-kb transcript and contains 3 Ig-like domains (disulfide loops), 8 FN type III-like domains (*hatched boxes*), a transmembrane domain (*TM*) and two protein tyrosine phosphatase (*PTP-1* and *PTP-2*) domains (Pot et al., 1991; Yu et al., 1992; Longo et al., 1993). Clone pRLAR631 was obtained from an adult rat hippocampus cDNA library and was identical to *RLAR* except for the absence of FNIII domains 4, 6, and 7 and the presence of a 33-bp insert (*LASE-a*) in the juxtamembrane region and a 27-bp insert (*LASE-c*) in FNIII domain 5. The insert of clone pRLARCB9 was derived by RT-PCR of adult rat cerebellum poly(A) RNA using a pair of primers corresponding to sites in FNIII domains 5 and 8. A 75-bp insert (*LASE-d*) was present between FNIII domains 5 and 6. Clone pRLAR18.1 was isolated from an adult rat hippocampus cDNA library and in the juxtamembrane region contained *LASE-a* and an additional 12-bp insert, *LASE-b*. Clone pRLAR4.0 was derived from an adult whole brain cDNA library. This clone had an alternative 3' untranslated sequence (beginning at arrow indicating the divergence point) which included several runs of tandem CAG repeats (*CAG*). A transcript size of ~5 kb was estimated by Northern blot studies using a probe corresponding to the alternative 3' untranslated region (see Fig. 9).

NISS. Additional LASE-a containing cDNA clones were identified (Figs. 1 and 3). The presence of introns flanking LASE-a (discussed below) demonstrated that LASE-a was a cassette exon (see Fig. 10).

The second difference between pRLAR4.0 and constitutive rat LAR was the presence in pRLAR4.0 of an alternative 3' untranslated sequence starting 240-bp downstream from LAR's stop codon and extending 1838 bp to a poly(A) tail (Figs. 1 and 2). This alternative 3' untranslated region contained an ~800-bp GC-rich segment consisting of many CAG trinucleotide repeats. The four longest uninterrupted stretches of tandem CAG repeats possessed 6, 7, 10, and 21 uninterrupted repeats (Fig. 2 A, *underlined*). Alignment of the CAG repeat region sequence with itself revealed four "super-repeats" of 30-bp each in which 27 out of 30 nucleotides were identical (Fig. 2 A, in boxes, B). Three of these 30-bp repeats were contiguous. Two of the four longest uninterrupted stretches of tandem CAG repeats (6 and 10 repeats) were located partially or entirely within the super-repeats while the longest tandem CAG repeat was ~200-bp downstream from the cluster of 30-bp super-repeats. The al-

under both denaturing and non-denaturing (Fig. 2) conditions. Subcloning and sequencing of PCR products showed polymorphism of the CAG repeat number and that PCR product from rat 3 contained one to three additional repeats compared to the other rats (Fig. 2D). PCR product from rats 2 and 5 contained four different repeat lengths. Only two alleles from each rat would be expected; therefore, these results suggested that CAG repeats can also expand or contract during PCR amplification or during plasmid replication in bacteria. Repeat PCR determinations of the Huntington's disease CAG repeat have demonstrated small variations in non-expanded alleles (11–37 repeats) of up to two repeats and a standard deviation of less than one repeat (Andrew et al., 1993). Variations in repeat number during bacterial cloning have not been described. Our findings that PCR product from rat 3 was of slightly greater length suggested that rat LAR CAG repeats have at least a small degree of polymorphism within an inbred rat strain.

Identification of a Third Site of Intracellular Alternative Splicing

We searched for additional LASE-a containing LAR mRNA isoforms by screening an adult rat hippocampus cDNA library using an oligonucleotide corresponding to the LASE-a region. One LASE-a containing LAR clone (pRLAR18.1; Figs. 1 and 3C) had an additional insert, termed LASE-b, which started 5-bp downstream from the transmembrane domain, interrupted the AGG codon (arg) and maintained the open reading frame. LASE-b predicted the insertion of the amino acids SKQE starting one amino acid downstream from the transmembrane domain followed by the reconstitution of the AGG codon. Cloning and sequencing flanking introns demonstrated that LASE-b was also a cassette exon (see Fig. 10).

LAR Extracellular Domains Are Alternatively Spliced

Screening the adult rat hippocampus library with the LASE-a probe also led to the isolation of an unexpected LAR clone which suggested extensive alternative splicing of the extracellular domain. Clone pRLAR631 (Figs. 1 and 3A) contained a 4.7-kb insert with sequence identical to constitutive rat LAR except that FNIII domains 4, 6, and 7 were deleted, a 27-bp insert was present within FNIII domain 5 and LASE-a was present in the juxtamembrane region. The 27-bp insert, LASE-c, maintained the open reading frame and encoded the nine amino acid sequence WRPEESDY. PCR using genomic DNA with two pairs of primers, each pair flanking one of the LASE-c splice junctions, suggested that LASE-c was flanked by introns and was therefore also an alternatively spliced cassette exon. In summary, screening of two cDNA libraries resulted in the isolation of 25 distinct LAR clones.

LAR Intracellular Domain Alternative Splicing Is Highly Regulated

RT-PCR using primers flanking sites of alternative splicing has proven to be an accurate technique for quantitative analysis of alternative splicing (see Materials and Methods). RT-PCR using primers flanking LASE-a was used to detect changes in the proportions of LAR transcripts containing LASE-a (Fig. 4). The proportion of LAR transcripts measured at each time point containing LASE-a significantly de-

creased during cortex development ($P < .05$, analysis of variance; ANOVA) and cerebellar development ($P < .0001$, ANOVA). After sciatic nerve transection, the proportion of LAR transcripts with LASE-a increased by 45% ($P < .05$, two-tailed t -test) in the nerve segment distal to the transection and increased by 30% in denervated muscle (without statistical significance). LASE-a was preferentially expressed in cortex, cerebellum, skeletal muscle and heart compared to six peripheral organs. The presence of LASE-a signal in human testes RNA demonstrated that LASE-a was also present in human as well as rat tissue. Interestingly, using this same pair of primers flanking LASE-a, PCR failed to amplify poly(A) RNA derived from mouse 3T3 fibroblasts. PC12 cell differentiation induced by NGF led to an ~50% decrease in the proportion of LASE-a containing LAR transcripts ($P < .05$, ANOVA).

RT-PCR with primers flanking LASE-b also demonstrated regulation of the proportion of LAR transcripts containing LASE-b (Fig. 5). Only a very small proportion of LAR transcripts contained LASE-b; bands containing LASE-b were not visible, unlike LASE-a containing bands, in ethidium-stained gels. To detect LASE-b we transferred RT-PCR product to nylon blots which were probed with a 32 P-labeled oligonucleotide. An oligonucleotide was designed which would preferentially hybridize to LASE-b containing PCR product to allow the simultaneous detection of product with and without LASE-b (Fig. 5). The relative proportion of LAR transcripts with LASE-b measured at each time point increased during development: a sixfold increase in the cortex from P0 to adult ($P < .05$, two-tailed t test) and a threefold increase (without statistical significance) in the cerebellum during the same time period. NGF-induced differentiation of PC12 cells caused a threefold increase ($P < .05$, two-tailed t -test) in the relative proportion of LAR transcripts with LASE-b. This proportion decreased by approximately sevenfold ($P < .0005$, two tailed t -test) in 3T3 fibroblasts by one day after reaching 100% confluence. LASE-b was preferentially expressed in brain LAR transcripts compared to transcripts in muscle and six peripheral organs. No LASE-b signal was detected in cultured astrocytes and only very faint signal was detected in cultured embryonic neurons. This faint signal was consistent with the observation that the proportion of LASE-b containing transcripts increased during development.

LAR Extracellular Domain Alternative Splicing Is Highly Regulated

Regulation of LASE-c splicing was studied with RT-PCR using primers corresponding to sites in FNIII domain 5 flanking LASE-c (Fig. 6). The relative proportion of LAR transcripts containing LASE-c decreased during development by ~60% in the cortex ($P < .05$, ANOVA), by 90% in the cerebellum ($P < .0001$, ANOVA), and by 50% in the spinal cord ($P < .0001$, ANOVA). LASE-c was not detected in normal or transected sciatic nerve. LASE-c was barely detectable in normal muscle but increased by ~11-fold after 2 wk of denervation ($P < .0001$, two tailed t -test). NGF-induced differentiation of PC12 cells caused an eightfold ($P < .005$, ANOVA) increase in the proportion of LASE-c containing transcripts. This proportion also increased by approximately 20-fold ($P < .0001$, two-tailed t -test) in fibroblast upon reaching confluence. LASE-c was preferentially

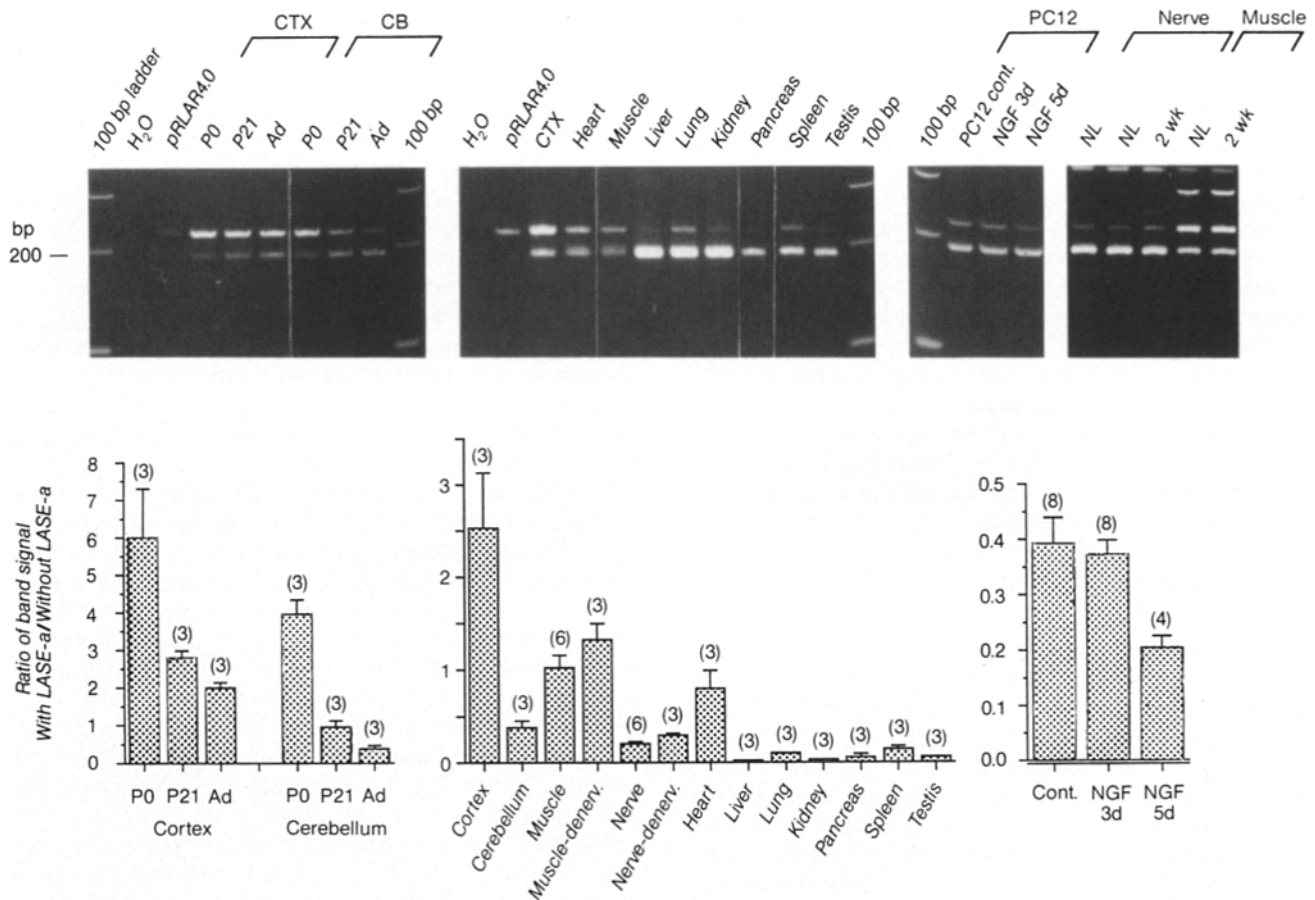

Figure 4. Regulation of LASE-a splicing. RT-PCR was performed using primers flanking LASE-a (nt 2011-2030 and nt 2201-2218, Fig. 3 A, predicting 175- and 208-bp products) with poly(A) RNA from the indicated tissues and cells. pRLAR4.0 plasmid DNA, containing the LASE-a 33-bp insert, was used as a control. Cortex (CTX) and cerebellum (CB) poly(A) RNA were obtained from three developmental time points (P0, day of birth; P21, 21-d postnatal; Ad, adult). All tissues in the middle panel were from adult rats except for testes RNA (adult human). RNA was analyzed from control proliferating PC12 cells (Cont.) and differentiated PC12 cells following 3 and 5 d of NGF treatment (Materials and Methods). RNA from normal sciatic nerve (NL nerve) and normal gastrocnemius muscle (NL muscle) was compared to RNA isolated from the distal nerve segment (Nerve-denerv.; 2 wk) and denervated gastrocnemius (Muscle-denerv.; 2 wk) 2-wk postsciatic nerve transection. Products were electrophoresed in 6% polyacrylamide gels, stained with ethidium bromide and photographed. Photograph negatives were analyzed by scanning densitometry and the ratio of the signal from the upper band (with LASE-a) over the signal from the lower band (without LASE-a) was calculated. The mean ratio \pm SE from separate RT-PCR reactions (number of reactions indicated in parentheses) is shown.

expressed in brain and spinal cord compared to nerve, normal muscle and six other peripheral organs. LASE-c was abundant in cultured neurons but not detected in cultured astrocytes.

Deletion of FNIII domain 4 was analyzed with primers corresponding to sites in FNIII domains 3 and 5 (Fig. 7). Significant developmental regulation of FNIII domain 4 splicing was found only in cerebellum in which there was a 2.5-fold decrease ($P < .001$, ANOVA) in the relative proportion of LAR transcripts missing this domain. Transection of sciatic nerve caused a fivefold increase ($P < .05$, ANOVA) in this proportion at one and two weeks posttransection in the distal nerve segment and an approximate 13-fold increase ($P < .0005$, two-tailed t -test) in muscle at 2-wk posttransection. PC12 cell differentiation was associated with a 50% increase ($P < .05$, ANOVA) in the proportion of transcripts missing FNIII domain 4. This proportion increased 4.5-fold (without reaching statistical significance) in 3T3 fibroblasts upon reaching confluence. Deletion of FNIII domain 4 pref-

erentially occurred in brain and spinal cord compared to muscle and six other peripheral organs and was evident in cultured neurons but not detected in cultured astrocytes.

Deletion of FNIII domains 6-7 was assessed with primers corresponding to sites in FNIII domains 5 and 8 (Fig. 8). The relative proportion of LAR transcripts missing the 6-7 domains decreased by 60% during cerebellar development ($P < .005$, ANOVA) and by 45% during spinal cord development ($P < .005$, ANOVA). Transection of sciatic nerve caused a small ($\sim 28\%$) but significant ($P < .05$, ANOVA) decrease in the proportion of transcripts with this deletion in the distal nerve trunk and a marked increase from undetectable levels in denervated muscle. Differentiation of PC12 cells induced a 4.3-fold increase in the proportion of transcripts with the 6-7 deletion ($P < .01$, ANOVA) and fibroblast confluence caused a 2.5-fold increase (without reaching statistical significance). The FNIII domain 6-7 deletion selectively occurred in brain, spinal cord and nerve and was not detected in muscle or the six other peripheral organs.

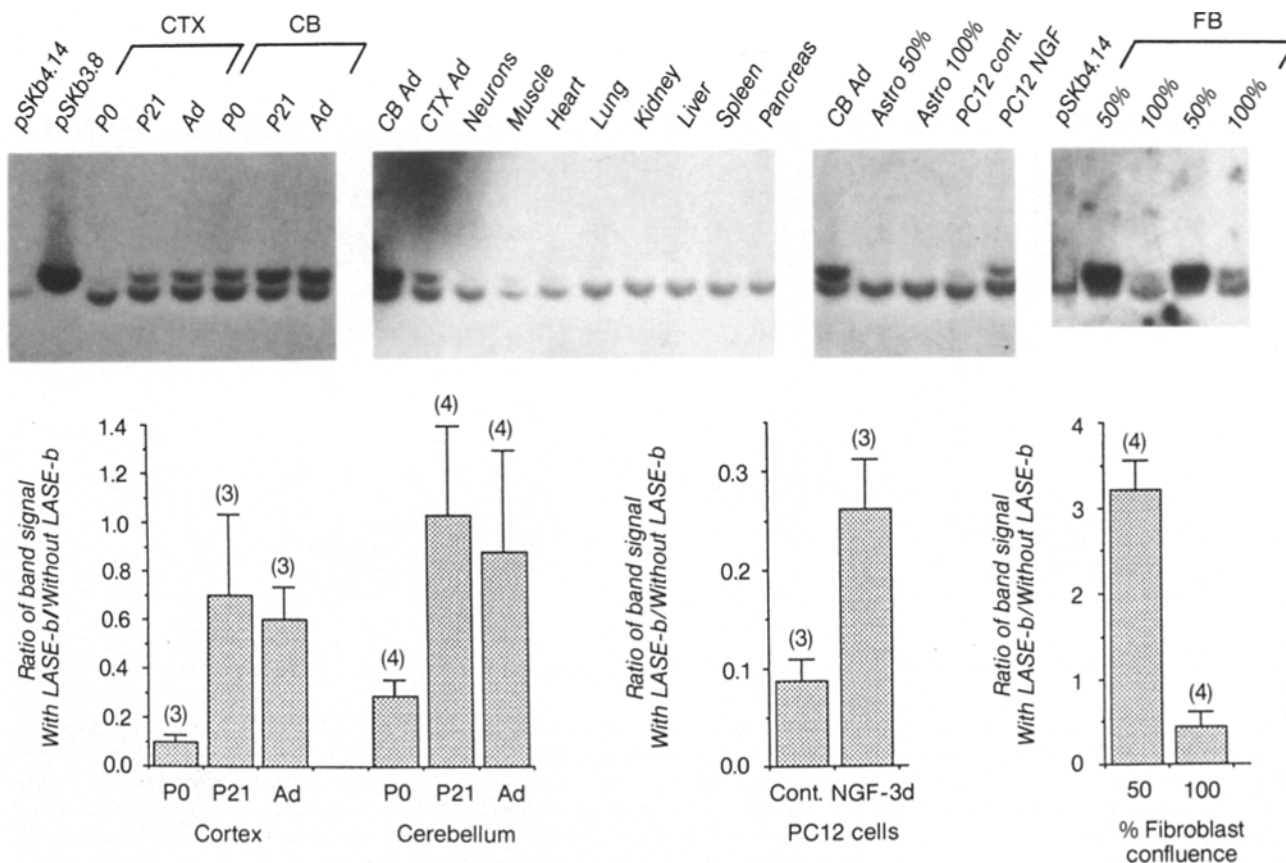

Figure 5. Regulation of LASE-b splicing. RT-PCR was performed with primers flanking LASE-b (nt 1913-1932 and nt 2033-2052, Fig. 3 A, predicting 140- and 152-bp products) with poly(A) RNA from the indicated tissues and cells. Plasmids pSKb4.14 and pSKb3.8 are cDNA clones with (upper band) and without (lower band) the 12-bp LASE-b insert, respectively, and were used as controls. Neuronal poly(A) RNA was derived from cultured E17 rat cortex neurons and astrocyte poly(A) RNA was derived from astrocyte cultures (at either 50 or 100% confluence) prepared from 2-d postnatal rat cortex. PC12 cells were differentiated with NGF for 3 d. Swiss 3T3 fibroblasts (FB) were harvested at either 50% confluence or 1 d after reaching 100% confluence. Since the upper band was not visible on ethidium stained polyacrylamide gels, bands were transferred to a nylon blot and probed with a ^{32}P -labeled 23-nucleotide probe corresponding to the 12 LASE-b nucleotides and the 11 adjacent downstream nucleotides. Blots were washed and then exposed to film for 2-3 d and band intensity measured by scanning densitometry. The ratio of signal from upper bands (with LASE-b) over the signal from the lower bands (without LASE-b) was calculated. The mean ratio \pm SE from separate RT-PCR reactions (number of reactions indicated in parentheses) is shown.

This deletion was present in cultured neurons but either not detected or barely detected in astrocytes.

RT-PCR analysis of FNIII domains 6-7 splicing unexpectedly demonstrated a band slightly larger than that predicted for constitutive rat LAR (Fig. 8 A, cerebellum, spinal cord, muscle, and heart). Subcloning and sequencing of this product derived from adult cerebellum poly(A) RNA revealed a 75-bp insert, LASE-d (Fig. 3 C), located between FNIII domains 5 and 6. This insert contained two in-frame stop codons and therefore constituted a retained intron (Smith et al., 1989). The identical LASE-d sequence was found using the same PCR primers with heart poly(A) RNA. This independently derived sequence demonstrated that the stop codons did not result from either Taq polymerase DNA replication or sequencing errors. Transcripts containing the LASE-d retained intron would lead to premature termination of protein translation prior to the transmembrane domain; therefore, the presence of LASE-d suggested the possibility of a secreted LAR isoform.

The relative proportions of LAR transcripts retaining

LASE-d were also examined (Fig. 8). The proportion of LASE-d containing transcripts increased by 4.5-fold ($P < .05$, ANOVA) in the cerebellum and twofold ($P < .05$, ANOVA) in the spinal cord during development. LASE-d was not detected in normal or transfected nerve and decreased by 50% ($P < .05$, two-tailed *t*-test) with muscle denervation. LASE-d was not detected in proliferating or differentiated PC12 cells. Fibroblasts reaching confluence led to a 40% decrease in the proportion of LASE-d containing transcripts ($P < .05$, two-tailed *t*-test). LASE-d was either not detected or barely detected in cultured embryonic neurons and astrocytes.

Northern Analysis Predicts a Developmentally Regulated, Markedly Truncated LAR Isoform

Previous Northern blot hybridization analysis of rat LAR had suggested the presence of LAR mRNA isoforms shorter than the ~ 8 -kb form including bands at ~ 7 kb and faint bands at ~ 5 kb (Longo et al., 1993). We used Northern blot

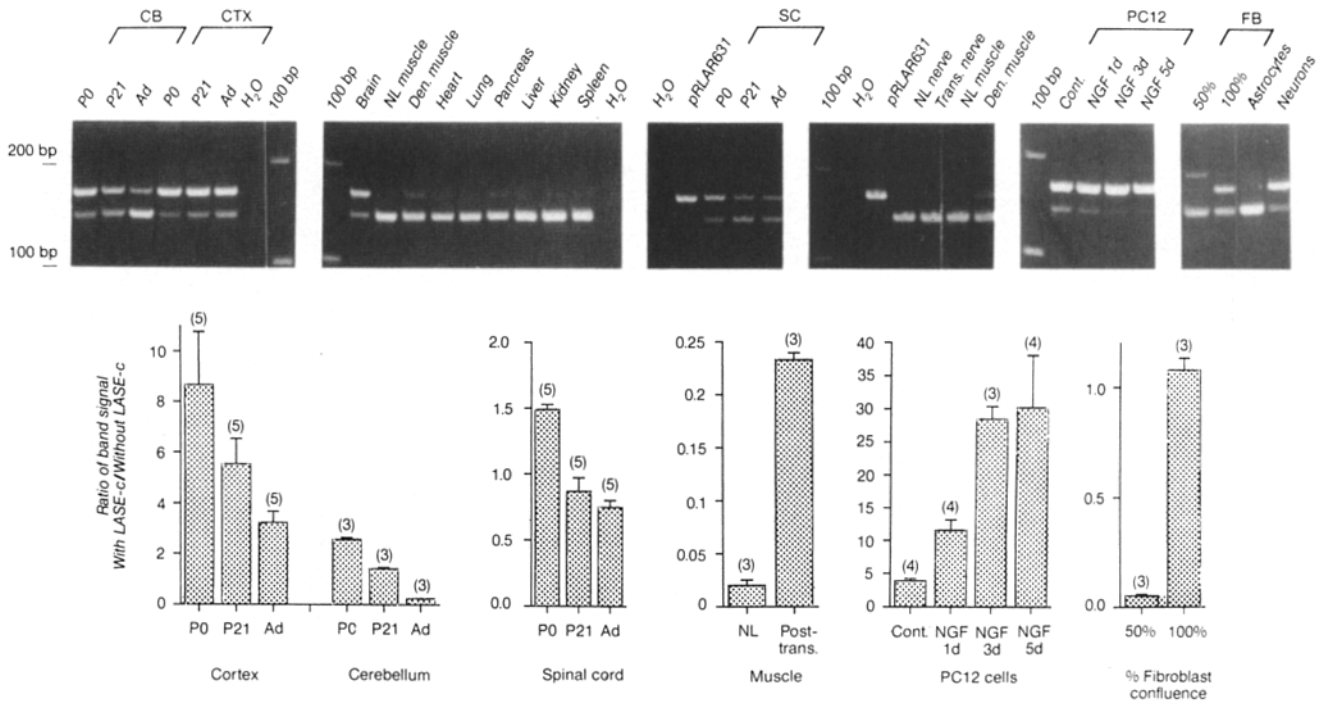

Figure 6. Regulation of LASE-c splicing. RT-PCR was performed with primers flanking LASE-c (nt 937-955 and nt 1081-1098, Fig. 3 A, predicting 135- and 162-bp products) with poly(A) RNA from the indicated tissues and cells. Plasmid pRLAR631 which contains LASE-c was used as a control. Labels for tissues and cells are as defined in previous figures (SC, spinal cord). RNA from normal sciatic nerve (NL nerve) and normal gastrocnemius (NL muscle) 2-wk postsciatic nerve transection was compared to RNA isolated from the distal nerve segment (trans. nerve) and denervated gastrocnemius (den. muscle). RT-PCR products were electrophoresed in 6% polyacrylamide gels, stained with ethidium bromide and photographed. Photograph negatives were analyzed by scanning densitometry and the ratio of the signal from the upper band (with LASE-c) over the signal from the lower band (without LASE-c) was calculated. The mean ratio \pm SE from separate RT-PCR reactions (number of reactions indicated in parentheses) is shown.

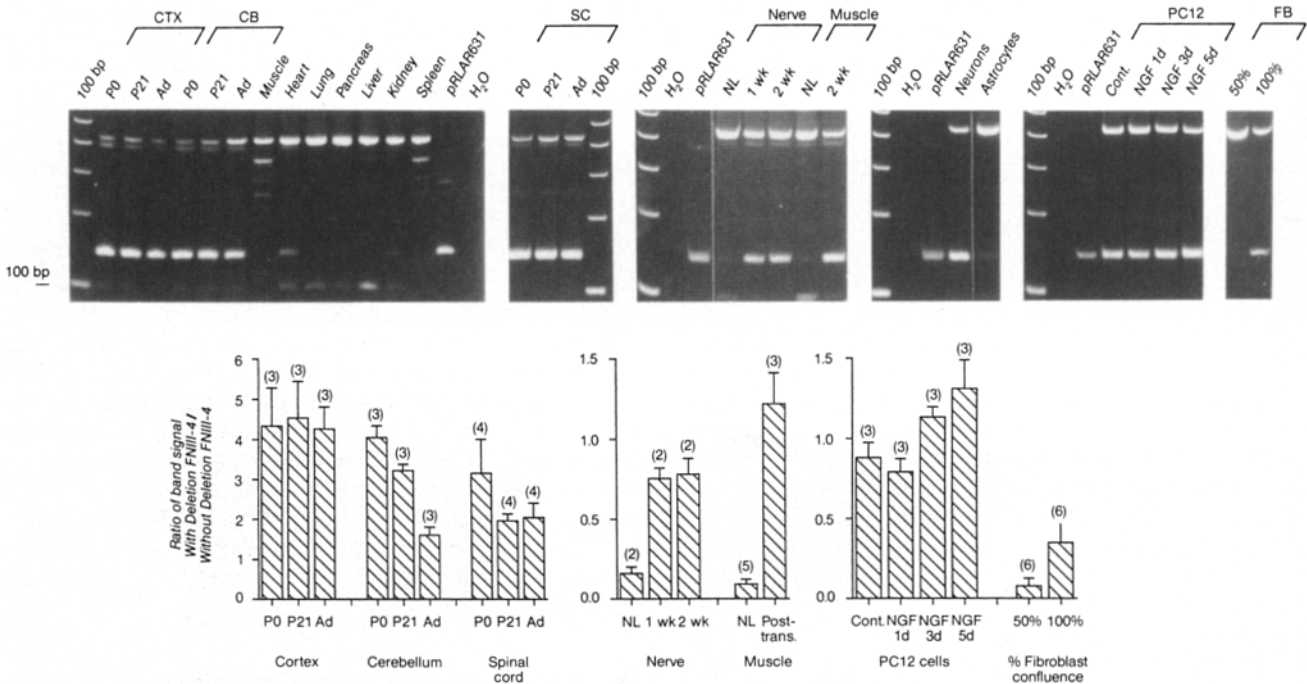

Figure 7. Regulation of FNIII domain 4 splicing. RT-PCR was performed with primers flanking FNIII domain 5 (nt 746-765 and nt 866-886, Fig. 3 A) with poly(A) RNA from the indicated tissues and cells. cDNA sequence predicted products of 141 (FNIII domain 4 deleted) and 445 bp (FNIII domain present). Plasmid pRLAR631 in which FNIII domain 4 is deleted was used as a control. Labels for tissues and cells are as defined in previous figures. RT-PCR products were electrophoresed in 6% polyacrylamide gels, stained with ethidium bromide and photographed. Photograph negatives were analyzed by scanning densitometry and the ratio of the signal from the lower band (without FNIII domain 4) over the signal from the upper band (with FNIII domain 4) was calculated. The mean ratio \pm SE from separate RT-PCR reactions (number of reactions indicated in parentheses) is shown.

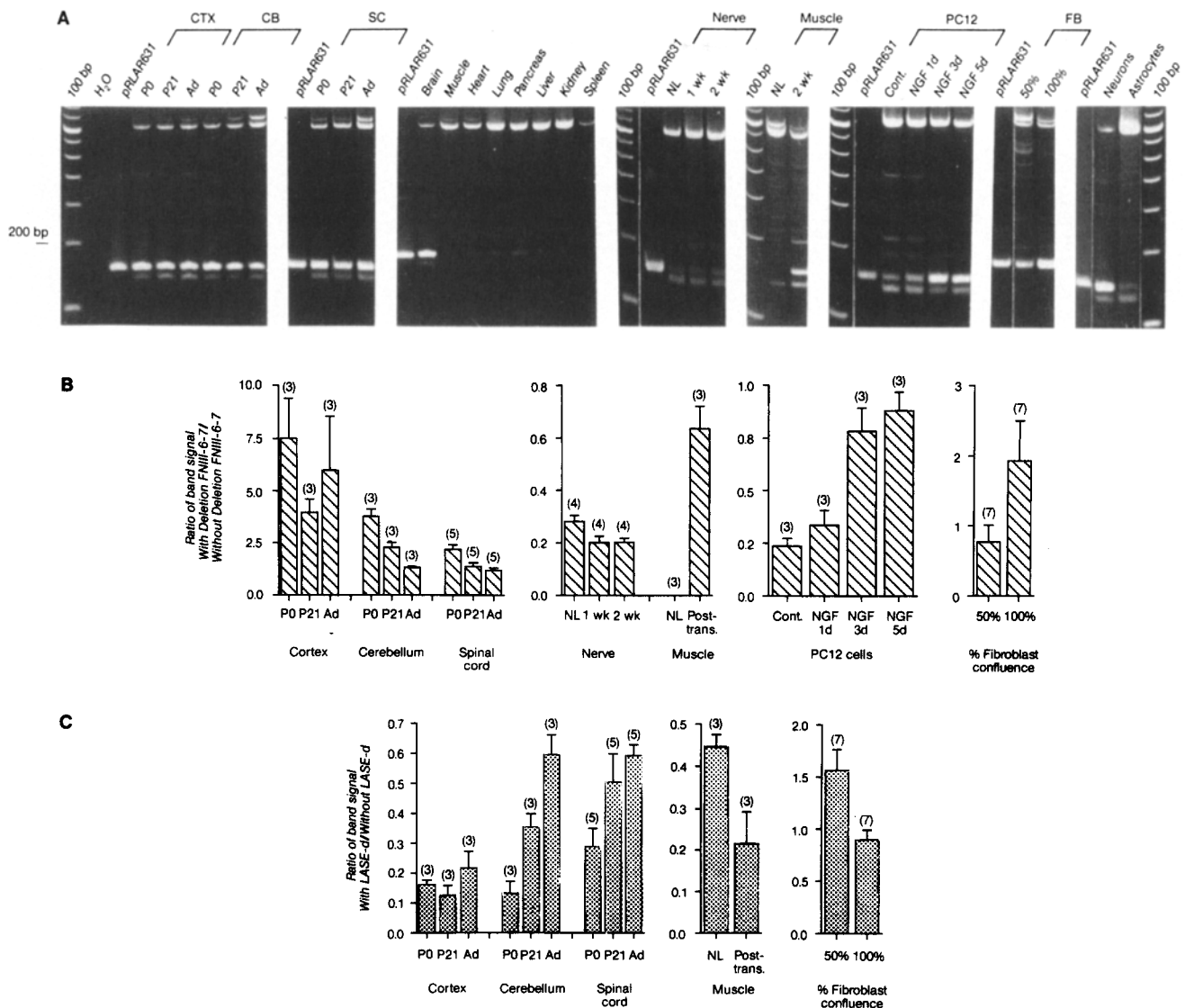

Figure 8. Regulation of FNIII domains 6–7 and LASE-d splicing. RT-PCR was performed with primers corresponding to sites in FNIII domains 5 and 8 (nt 1067-1088 and nt 1196-1217, Fig. 3 A) with poly(A) RNA from the indicated tissues and cells. cDNA sequence predicted products of 151 bp (FNIII domains 6–7 deleted) and 732 bp (FNIII domains 6–7 present). Plasmid pRLAR631 in which FNIII domains 6–7 are deleted was used as a control. Labels for tissues and cells are as defined in previous figures. RT-PCR products were electrophoresed in 6% polyacrylamide gels, stained with ethidium bromide, and photographed. Two unexpected prominent bands were also present; a band slightly above the 732-bp band and a band slightly below the 151-bp band. PCR product from these unexpected bands and the two expected bands was isolated, subcloned into pCR vector (Invitrogen) and sequenced. The upper band contained the LASE-d 75-bp insert (clone pRLAR CB9 as described in Fig. 3). The lower band sequence had no identity to LAR, consistent with non-specific priming. The two expected bands contained the predicted LAR sequence. Photograph negatives were analyzed by scanning densitometry and the ratio of signal from the expected lower band (without FNIII domains 6–7) over the 732-bp band (with FNIII domains 6–7) was calculated. The ratio of signal from the uppermost band (with LASE-d) over the signal from the 732-bp band (with FNIII domains 6–7) was also calculated. The mean ratio \pm SE from separate RT-PCR reactions (number of reactions indicated in parentheses) is shown.

analysis to determine which transcripts contained the alternative 3' untranslated region. Northern blots probed under high-stringency conditions with riboprobe transcribed from the LAR alternative 3' untranslated region revealed the presence of an \sim 5-kb transcript in cortex, cerebellum, and several peripheral organs (Fig. 9 A). This \sim 5-kb transcript most likely contained \sim 1 kb of additional sequence upstream of the starting point of the clone pRLAR4.0 insert, predicting a significantly truncated LAR receptor with most of the ex-

tracellular domain deleted (Fig. 1). Developmental regulation of the \sim 5-kb alternative 3' untranslated region transcript was confirmed by two additional Northern blots with cortex and cerebellum poly(A) RNA which showed that this transcript was most abundant at P21 in the cortex and at P0 in the cerebellum (Fig. 9 A). Expression of the \sim 5-kb transcript in peripheral organs was not quantitated, although this transcript appeared to be more abundant in several non-neural tissues, especially in lung.

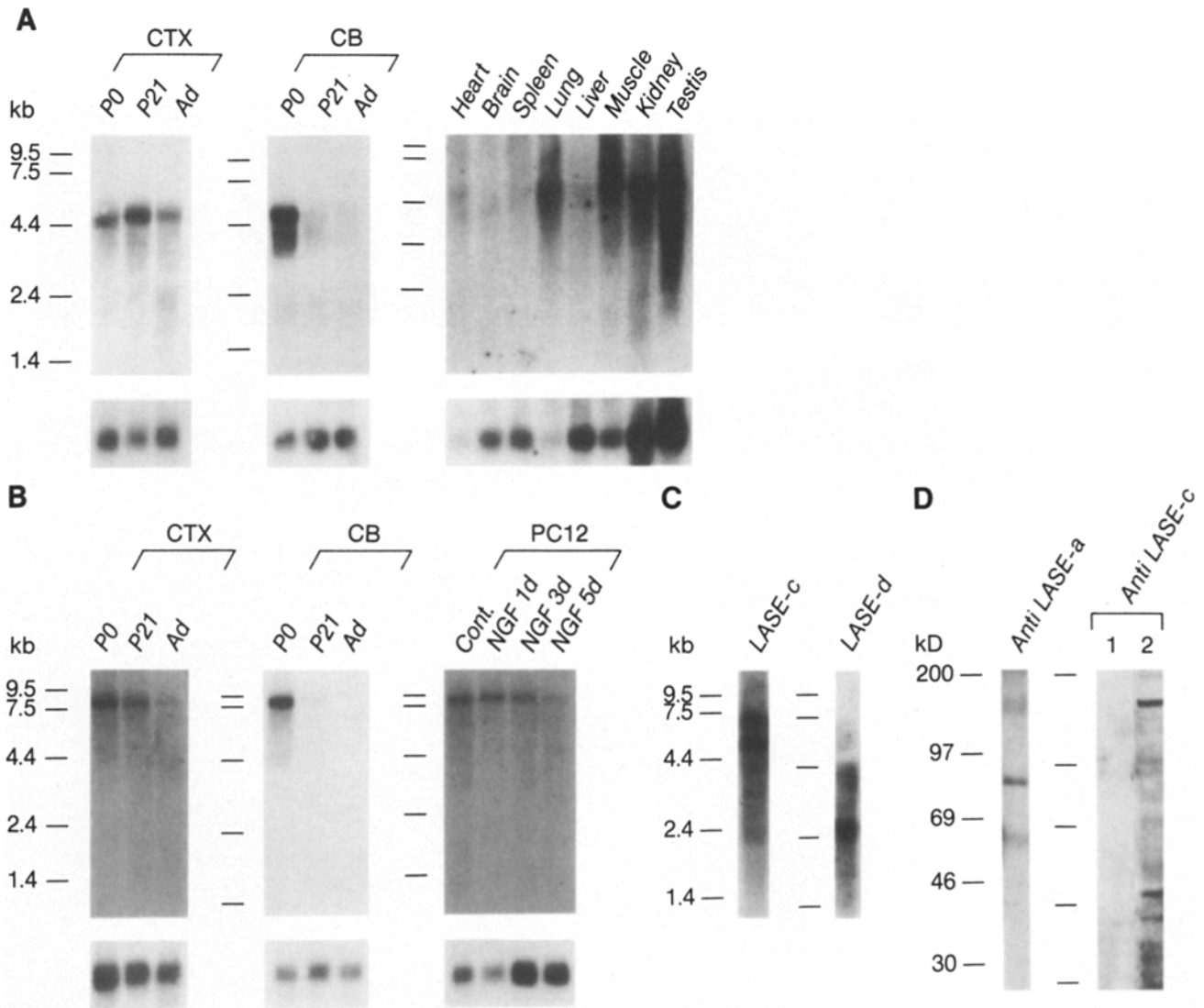

Figure 9. Northern and Western analysis of RLAR isoforms. Poly(A) RNA was isolated from the indicated tissue and PC12 cells (control cells and following NGF treatment for 1, 3, and 5 days) and 4 μ g of each preparation was loaded per lane. The blot with organ RNA (obtained from Clontech) contained approximately 2 μ g poly(A) RNA per lane. The location of RNA size markers is shown on the left of each blot. The lower panel for each blot represents the same blot reprobed with a cyclophilin riboprobe to control for loading variation. (A) Blots were probed with an antisense riboprobe transcribed from a construct containing the alternative 3' untranslated region found in LAR clone pRLAR4.0 and washed under high stringency conditions as described under Materials and Methods. (B) Blots were probed with a 33-nucleotide antisense probe corresponding to the LASE-a 33-bp insert. (C) Poly(A) RNA isolated from adult cortex and 4 μ g loaded per lane. The blot on the left was probed with a 37-nucleotide antisense probe corresponding to the LASE-c 27-bp insert and including five additional nucleotides on each side corresponding sequence flanking LASE-c. The blot on the right was probed with a 75-nucleotide antisense probe corresponding to the 75-bp LASE-d insert. (D) Western blot analysis with LASE-a and LASE-c antibodies. Protein extract from neonatal rat cerebellum was immunoprecipitated with LASE-a antiserum (*left*) and resolved by SDS gel electrophoresis. The resulting immunoblot was hybridized with crude LASE-a antiserum followed by incubation with alkaline phosphatase-linked goat anti-rabbit IgG. Bands were visualized by incubation with chemiluminescent substrate followed by exposure to x-ray film for 15 min (see Materials and Methods). The same protein extract was also directly resolved by SDS gel electrophoresis and the resulting immunoblot hybridized with affinity-purified LASE-c antibody (*right*). For lane 1, antibody was pre-incubated with LASE-c peptide; lane 2 is without peptide pre-incubation.

Northern Analysis Also Suggests Developmental Regulation of LAR Isoforms

Northern analysis was conducted with a LASE-a 33-nucleotide antisense probe (Fig. 9 B). LASE-a was found predominantly in the \sim 8-kb LAR isoform; a faint signal was detected at \sim 5 kb, consistent with the presence of LASE-a in transcripts represented by the pRLAR4.0 clone. Two addi-

tional Northern blots with cortex and cerebellum poly(A) RNA also showed that, compared to cyclophilin expression, LASE-a expression decreased during development. Three separate Northern analyses using PC12 poly(A) RNA demonstrated that LASE-a expression decreased during NGF-induced PC12 differentiation. The developmentally regulated decrease in LASE-a abundance as determined by

Northern analysis in cortex, cerebellum and PC12 cells was consistent with our findings using RT-PCR. Previous Northern blot studies using probe corresponding to the 3' end of constitutive LAR demonstrated ~8- and ~7-kb bands (Longo et al., 1993). The ~7-kb band is likely to represent LAR transcripts with FNIII domains 4, 6, and 7 (~900 bp) deleted. These Northern studies demonstrated that during development the ~7-kb band signal decreased in proportion to the ~8-kb band, consistent with the RT-PCR findings reported here (Fig. 7 and 8). Overall, developmental changes measured by RT-PCR studies were consistent with Northern analyses.

Northern analysis of adult cortex poly(A) RNA with an oligonucleotide antisense probe corresponding to LASE-c identified transcripts of ~7 kb, ~5 kb, and several shorter transcripts with faint signal including those at ~2.5 and ~2.3 kb (Fig. 9 C). Analysis of the same RNA with a 75-nucleotide antisense probe corresponding to the 75-bp LASE-d insert detected a prominent band at ~2.5 kb and a faint band at ~4 kb (Fig. 9 C). A 40-nucleotide antisense probe containing only the 40-most downstream bases of LASE-d also identified the ~2.5-kb band and further supported the identity of this band as LAR (not shown). The signal observed at ~2.5 kb using both LASE-c and LASE-d probes suggested that LAR transcripts existed that contain both LASE-c and LASE-d. Since the ~2.5-kb signal generated by the LASE-c probe was faint, RT-PCR was used to determine if transcripts existed containing both LASE-c and LASE-d. RT-PCR using a 27-nucleotide upstream primer corresponding to LASE-c and the 40 nucleotide antisense oligonucleotide corresponding to LASE-d for a downstream primer yielded product of predicted size and therefore confirmed the existence of LAR transcripts containing both LASE-c and LASE-d.

LASE-a and LASE-c Inserts Are Present in LAR Protein

LAR protein is cleaved intracellularly into a ~150-kD extracellular subunit containing the immunoglobulin and FNIII domains and a ~85-kD subunit containing a short segment of the extracellular region, the transmembrane region and the cytoplasmic domains (Streuli et al., 1992; Yu et al., 1992). If LASE-a and LASE-c inserts were translated, LASE-a antibodies would be expected to identify the ~85-kD subunit and LASE-c antibodies an ~150-kD subunit. As shown in Fig. 9 D, LASE-a antisera (but not pre-immune sera) precipitated a ~85-kD protein, demonstrating that LASE-a amino acids are present in LAR protein. Affinity-purified LASE-a antibody also specifically identified the ~85-kD protein (not shown). Affinity-purified LASE-c antibody hybridized with a ~150-kD protein, demonstrating that LASE-c amino acids are also present in LAR protein. Previous studies demonstrating the ~85- and ~150-kD cleavage products of LAR examined LAR expression by cultured cells (Streuli et al., 1992; Yu et al., 1992). The present study demonstrated that LAR also undergoes cleavage in brain tissue *in vivo*.

Given the ~2.5-kb transcript demonstrated by LASE-d probes and the concomitant presence of LASE-c and LASE-d in LAR transcripts, LASE-c antibodies would be predicted to recognize an additional protein considerably smaller than

the ~150-kD species. RT-PCR demonstrated that LASE-d is present in LAR transcripts containing FNIII domains 5-8 (Fig. 8). If stop codons in LASE-d caused termination of translation immediately downstream of FNIII domain 5, the ~1 kb of transcript corresponding to FNIII domains 6-8 would not be translated. A LASE-d containing transcript of ~2.5 kb, would therefore have ~1.5 kb of transcript available for open reading frame and 5'/3' untranslated regions (Fig. 1). Thus, LASE-d containing transcripts would be expected to generate protein(s) in the range of 40-50 kD. As this analysis predicted, affinity purified LASE-c antibodies also identified proteins of ~42 and ~49 kD (Fig. 9 D). These smaller proteins could represent LAR protein isoforms truncated at the LASE-d insert prior to the transmembrane domain. Their direct identification will require protein sequencing. Since the LASE-d insert predicted the addition of only two amino acids before the first stop codon is reached (Fig. 3), no attempt was made to raise LASE-d specific antisera.

Splice Junction Sequence Analysis

RT-PCR studies suggested that LASE-b containing LAR transcripts were very rare compared to those with LASE-a. We determined whether the presence of strong or weak splice donor or acceptor sites (Smith et al., 1989) correlated with this trend by cloning and sequencing introns flanking these alternatively spliced exons (Fig. 10). Intron analysis demonstrated that the splice acceptor site immediately upstream from LASE-b, which would be used for its retention, had fewer pyrimidines (7/12) than typical acceptor sites (11-12/12) while the acceptor site downstream, which would be used to eliminate LASE-b, had a more typical consensus sequence (11/12 pyrimidines). In contrast, the acceptor site upstream from LASE-a had a favorable sequence (11/12 pyrimidines). This finding was consistent with the very low abundance of LASE-b containing transcripts, although other *cis* elements as well as *trans*-acting factors are also likely to regulate LASE-a and LASE-b splicing. The LASE-d retained intron was also further characterized at the genomic DNA level (Fig. 10). Genomic sequence revealed that FNIII domains 6 and 7 were present in the same exon and that LASE-d served as the intron between FNIII domains 5 and 6-7.

Discussion

This study demonstrates tissue-preferential and highly-regulated LAR alternative splicing evident at both the mRNA and protein level. An over-view of splice variant regulation reveals several patterns which suggest specialized functions for LAR in the nervous system and support our hypothesis that LAR has a role in neural development (Table I). First, all six identified alternatively spliced forms of LAR occurred preferentially in neural or neuromuscular tissue. Expression of LASE-b, LASE-c, LASE-d, and FNIII deletions 4 and 6-7 was compared in cultured neurons and astrocytes. With the exception of LASE-d, which was not detected in either neurons or astrocytes, each alternative isoform examined was preferentially expressed in neurons. *In situ* hybridization studies with LASE-specific probes, in progress, will establish whether LASE expression is also neuronal-selective *in vivo*. In initial

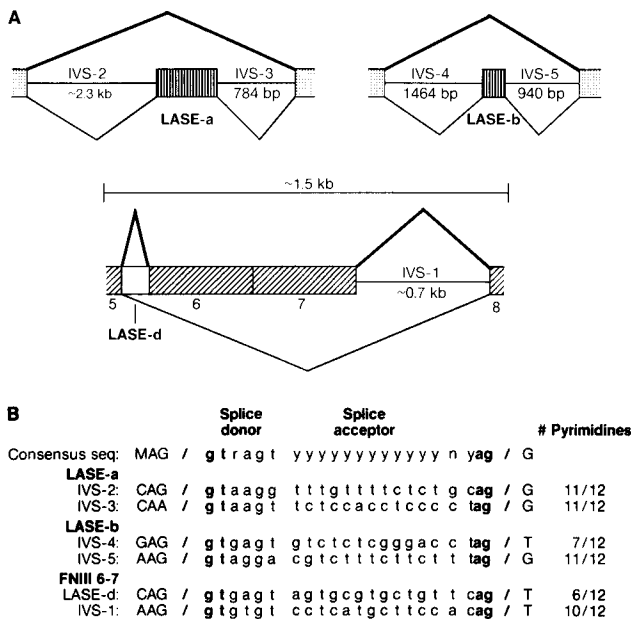

Figure 10. Analysis of introns flanking LASEs. Nucleotide sequences of LASE exon-intron boundaries. (A) LASE-a and LASE-b are alternatively spliced cassette exons. Alternative splicing is indicated by thin lines and constitutive splicing is shown by heavy lines. LASE-d contains in-frame stop codons and therefore is a retained intron. FNIII domains 6 and 7 are contained in one exon. (IVS, intervening intron sequence). (B) Splice junction sequence. RT-PCR (Figs. 4 and 5) demonstrated that LASE-b was rarely retained in LAR transcripts compared to LASE-a. The weak splice acceptor site upstream of LASE-b (7/12 pyrimidines, IVS-4) compared to the downstream acceptor site (11/12 pyrimidines, IVS-5) is consistent with the relatively low abundance of LASE-b containing transcripts. Upper case, exon sequence; /, splice junction; lower case, intron sequence; Y, pyrimidines C or T; M, A or C; R, purines A or G.

in situ studies of LASE-a and LASE-c, both were predominantly expressed by specific subsets of neurons (Zhang, J. S., and F. M. Longo, unpublished observations). Preliminary immunohistology studies with antibodies raised against LASE-a and LASE-c peptides also suggest selective neuronal LASE-a and LASE-c expression.

Second, all six LAR alternative splicing forms were developmentally regulated, suggesting that some isoforms are more characteristic of developmental processes and others are more typical of the adult or stabilized nervous system. It is especially interesting to note that proportions of five out of five variants examined in muscle shifted toward "developmental" isoforms following denervation (Table I, columns 1 and 5). This finding is analogous to N-CAM reversion to embryonic forms following peripheral nerve transection (Nieke and Schachner, 1985) and raises the possibility of LAR involvement in neurite-target interactions during development or regeneration. Nerve transection-induced alternative splicing in distal nerve segments suggests that specific LAR isoforms are involved in regenerative neurite outgrowth through denervated nerve (Table I, columns 1 and 4).

Third, all five splice variants detected in 3T3 fibroblasts were regulated by degree of cell confluence and confluence caused a shift toward "developmental" arrangements of FNIII domains. Several observations suggest that receptor-linked

Table I. Coordination of Cell Growth State and Novel LAR Isoforms

	During CNS development	NGF-induced PC12 differentiation	3T3FB reaching confluence	Nerve post-denervation	Muscle, post-denervation
Intracellular					
LASE-a	↓	↓	—	↑	↑ (SNE)
LASE-b	↑	↑	↓	—	—
Extracellular					
LASE-c	↓	↑	↑	not detected	↑
LASE-d	↑	not detected	↓	not detected	↓
FNIII 4 deletion	↓	↑	↑ (SNE)	↑	↑
FNIII 6-7 deletion	↓	↑	↑ (SNE)	↓	↑

Statistically significant changes in proportion of LAR transcripts containing each splice variant as determined by RT-PCR. A dash (—) indicates not tested and SNE indicates statistical significance not established. Data from Figs. 4–8 are summarized.

PTPs provide a mechanism by which cell-cell contact inhibits cell proliferation: (a) some receptor-linked PTPs contain cell adhesion molecule motifs; (b) tyrosine phosphatase activity in 3T3 fibroblasts is increased in confluent growth-arrested cells compared to activity in low density proliferating cells (Pallen and Tong, 1991); (c) LAR mRNA expression in 3T3 fibroblasts is increased by cell confluence (Longo et al., 1993); and (d) conditions causing decreased cell-substrate adhesion lead to activation of tyrosine phosphatases (Maher, 1993). The role of FNIII repeats in promoting cell spreading (Frei et al., 1992) and regulation of LAR FNIII domain splicing by cell confluence shown in this study raises the possibility that LAR mediates and/or responds to cell-cell and/or cell-substrate interactions.

Modulation of alternative LAR splicing occurs at the cellular level. The developmental changes in LAR splice patterns seen in brain tissues could have resulted from changing proportions of specific cell populations, each consistently expressing a given set of LAR isoforms. Instead, alternative splicing may be regulated during differentiation of a given cell type. The latter mechanism is consistent with our observation that all five splice variants found in PC12 cells were regulated during NGF-induced differentiation. For both intracellular domain variants (LASE-a and LASE-b), in vivo developmental changes paralleled changes seen during PC12 cell differentiation. For all three extracellular domain variants however, in vivo and PC12 cell development demonstrated opposite trends. The difference between in vivo and PC12 cell splicing regulation of extracellular domains may be related to the fact that in vivo development during this time period includes events occurring subsequent to neurite outgrowth such as synaptogenesis (Jacobson, 1978). Such additional events may be associated with different splice patterns. LAR splicing may be regulated differentially in different neuronal populations.

A cell surface molecule with a large number of isoforms would be an important candidate for mediating specific and highly regulated cell-cell or cell-extracellular matrix interactions. Studies by Zisch et al. (1992) suggested that alternative splicing of FNIII repeats in the extracellular matrix protein, tenascin, regulated its binding affinity to the neuronal surface glycoprotein contactin/F11. N-CAM expression studies with constructs containing both or either FNIII domains demonstrated that the combination of both N-CAM FNIII

repeats more effectively promoted neurite outgrowth in vitro compared to individual domains (Frei et al., 1992), thereby suggesting that different combinations of repetitive FNIII units may differentially regulate neurite outgrowth. However, developmentally regulated or tissue-specific alternative splicing of FNIII domain cassettes within N-CAM itself or within receptor-linked PTPs has not been demonstrated.

Developmentally regulated and nervous system-preferential combinatorial use of LAR FNIII domain cassette exons constitutes a candidate novel mechanism for regulating neurite outgrowth and establishing specific axonal connections. Combinatorial use of LASE-a, -b, and -c exons and the FNIII 4 and 6-7 domains could potentially give rise to 32 different LAR isoforms with four additional isoforms if LASE-d led to a truncated protein. The existence of cDNA clones containing both LASE-a and LASE-b or containing LASE-a without LASE-b (Fig. 1) demonstrated that splicing of some exons can occur independently. Independent exon use was further suggested by opposite trends in the proportion of LAR transcripts containing FNIII domain 4 compared to domains 6-7 in nerve and muscle following nerve transection. Within a specific brain or tissue region, different cells may differentially splice LAR; therefore, determination of the actual extent of LAR isoform variability will require further studies in uniform cell populations.

The LASE-c extracellular exon has several features similar to the N-CAM variably alternatively spliced exon (VASE). This exon contributes a 10-amino acid segment to N-CAM's fourth Ig domain and its expression increases during development (Small and Akeson, 1990). Findings that incorporation of VASE inhibits N-CAM's neurite-promoting effect led to the suggestion that VASE may negatively modulate synaptic plasticity and promote stability of the adult nervous system (Doherty et al., 1992; Doherty and Walsh, 1994). Within N-CAM, Ig domains predominantly regulate cell adhesion and FNIII domains contribute significantly to neurite outgrowth (Frei et al., 1992). It is not known if LAR affects neurite outgrowth, although the developmentally regulated expression of the LAR protein along axons during *Drosophila* development and the preferential expression of LASE-c in neurons and neural tissue raises the possibility that LASE-c splicing into LAR FNIII domain 5 may somehow alter its function and thereby modulate neurite outgrowth. Differences between LASE-c and VASE include: VASE is not expressed in PC12 cells (Small and Akeson, 1990) and since N-CAM itself is not expressed over a broad range of non-neuronal tissue, VASE splicing cannot be viewed as nervous system preferential. Expression of LAR constructs with and without LASE-c and current characterization of LASE-c antibodies will contribute to LAR functional studies.

Like virtually all members of the receptor PTP gene family, the ligand(s) for the LAR receptor has not been identified. The existence of a secreted LAR isoform would raise the possibility that soluble LAR could function as an LAR ligand by homophilic interaction. Therefore, it was of particular interest to discover an mRNA transcript which predicted the expression of a soluble extracellular isoform. The LASE-d retained intron included two in-frame stop codons that would prematurely terminate protein translation upstream from the hydrophobic transmembrane domain, between FNIII domains 5 and 6. In studies of rat N-CAM, Gower et al. (1988) demonstrated that an extracellular domain alternatively spliced ele-

ment contained an in-frame stop codon and generated a secreted isoform. Determining whether LASE-d containing LAR transcripts actually generate secreted LAR will require further studies at the protein level. Our observation that LASE-d splicing is preferential to neural and muscle tissue and that it is modulated during development and subsequent to denervation supports the notion that a secreted LAR isoform may have a physiological role.

Alternative splicing in the juxtamembrane region of receptor-linked PTPs has not been previously reported. There are several possible functions for splicing of the predicted LASE-a 11 amino acids and LASE-b 4 amino acids into the intracellular juxtamembrane region of LAR. First, these inserts could influence the intracellular location of LAR by promoting interaction with other proteins such as cytoskeletal elements. Screening of these sequences did not reveal known cytoskeletal-interaction motifs (Luna and Hitt, 1992) or other motifs influencing intracellular location (Mauro and Dixon, 1994). Second, inserts could modulate LAR-LAR interaction, such as clustering, and thereby regulate LAR function. Third, the presence of these inserts could change LAR protein structure and thereby alter activity of the nearby tyrosine phosphatase domain. Fourth, serines introduced by LASE-a (SSAPSCPNISS) and LASE-b (SKQE) represent potential substrates for Ser/Thr kinases. While these serines are not a part of known substrate consensus sequences for protein kinases (Aitken, 1990), protein kinases such as cyclin-p34^{cdc2} can phosphorylate serines located outside of known consensus motifs (Satterwhite et al., 1992). Finally, the presence of a cysteine residue in LASE-a raises the possibility of receptor oligomerization mediated by disulfide bond formation. For example, Ltk transmembrane tyrosine kinase is activated by the formation of disulfide-linked multimers (Bauskin et al., 1991).

Another unexpected finding of these studies of LAR isoforms was the presence of an alternative 3' untranslated region containing extensive tandem CAG repeats. Expansion of unstable GC-rich tandem trinucleotide repeats during DNA replication has recently been found to be the cause of several currently identified neurological disorders (reviewed in Richards and Sutherland, 1992; Martin, 1993; Miwa, 1994). Interestingly, in five of these diseases (Huntington's disease, spinobulbar muscular atrophy, spinocerebellar ataxia type 1, dentatorubral-pallidoluysian atrophy, and myotonic dystrophy) a CAG repeat expands. Two mechanisms have been proposed to cause expansion of tandem repeats: (a) unequal crossing-over between misaligned allelic tandem arrays producing one tandem array with more repeats; and (b) DNA polymerase slippage in which transient dissociation of template and primer strands during DNA replication followed by misaligned reannealing leads to expanded tract lengths without non-repeat intervening sequence (Wells and Sinden, 1993; Richards and Sutherland, 1994). The presence of the 30-bp super repeats in association with the LAR CAG repeats is of interest because super-repeats have not been observed in repeat-containing genes described thus far and they suggest that the first mechanism was at least one process contributing to the formation of the rat LAR CAG repeat region.

The number of tandem repeats in normal alleles of genes associated with CAG repeat disorders ranges from 5 to 37. In general, repeat length correlates with degree of instability and tendency to expand (Richards and Sutherland, 1992,

1994). Screening of human cDNA libraries for additional trinucleotide repeat genes has yielded some 15–20 additional genes (Riggins et al., 1992; Li et al., 1993). These repeats were polymorphic and most frequently consisted of only 5–10 uninterrupted tandem repeats; the greatest number reported was 18. Thus, our finding of up to 24 tandem CAG repeats in the rat LAR gene is greater than that seen in most non-disease-related genes and well within the range of the normal alleles of the disease-related genes. The LAR CAG repeats are also unusual in that they are present in the context of an exonic ~800-bp CG-rich, and therefore potentially unstable, region. The conservation of the 3' untranslated region CAG repeat in the human and mouse myotonic dystrophy genes (Jansen et al., 1992) raises the possibility that the repeat found in the rat LAR gene is also present in the human gene.

The discovery of extensive CAG repeats in a gene potentially involved in neurodevelopment would be of particular interest in light of studies demonstrating the existence of anticipation in several neuropsychiatric disorders (Zheng et al., 1993). It is also intriguing to note that PTPs may function as tumor suppressor genes (Walton and Dixon, 1993) and that the chromosomal location of human LAR at 1p32-33 (Streuli et al., 1992; Jirik et al., 1992) is similar to the loci for candidate tumor suppressor genes which may be disrupted in several malignancies including neuroblastoma, pheochromocytoma, some astrocytomas, and ductal breast cancer (Matthew et al., 1987; Rittke et al., 1989; Moley et al., 1992; Kimmel et al., 1992). Current analysis of human 3' untranslated region cDNA and genomic LAR clones isolated in our laboratory will determine if extensive CAG repeats are also present in the human LAR gene.

We acknowledge the expert technical assistance of Francine Compango and Jackie Zhao. We thank Dr. Ella Magal in the laboratory of Dr. Silvio Varon for assistance with cortical neuron and glial cultures. Dr. John Martignetti in the Department of Pediatrics at Mt. Sinai Medical Center (New York, NY) critically reviewed this manuscript.

Supported by NIA ROI AG09873, United Cerebral Palsy, American Paralysis Association and the Veterans Administration; studies on CAG repeats supported by the American Cancer Society.

Received for publication 11 August 1994 and in revised form 28 October 1994.

Note Added in Proof. O'Grady et al. (1994) have found several forms of extracellular domain alternative splicing in human LAR.

References

Aitken, A. 1990. Identification of Protein Consensus Sequences. Ellis Harwood Limited, Chichester, West Sussex, England. 167 pp.

Andrew, S. E., Y. P. Goldberg, B. Kremer, H. Telenius, J. Theirlmann, S. Adam, E. Starr, F. Squitieri, B. Lin, M. A. Kalchman, R. K. Graham, and M. R. Hayden. 1993. The relationship between trinucleotide (CAG) repeat length and clinical features of Huntington's disease. *Nature Genet.* 4: 398–403.

Bauskin, A. R., I. Alkalay, and Y. Ben-Neriah. 1991. Redox regulation of a protein tyrosine kinase in the endoplasmic reticulum. *Cell.* 66:685–696.

Brady-Kalnay, S. M., A. J. Flint, and N. K. Tonks. 1993. Homophilic binding of PTP μ , a receptor-type protein tyrosine phosphatase, can mediate cell-cell aggregation. *J. Cell Biol.* 122:961–972.

Chao, M. V. 1992. Neurotrophin receptors: a window into neuronal differentiation. *Neuron.* 9:583–593.

Charbonneau, H., and N. K. Tonks. 1992. 1002 protein phosphatases? *Annu. Rev. Cell Biol.* 8:463–493.

Charbonneau, H., N. K. Tonks, K. A. Walsh, and E. H. Fisher. 1988. The leukocyte common antigen (CD45): a putative receptor-linked protein tyrosine phosphatase. *Proc. Natl. Acad. Sci. USA.* 85:7182–7186.

Cross, M., and T. M. Dexter. 1991. Growth factors in development, transformation, and tumorigenesis. *Cell.* 64:271–280.

Danielson, P. E., S. Forss-Peter, M. A. Brow, L. Calavetta, J. Douglass, R. J. Milner, and J. G. Sutcliffe. 1988. p1B15: a cDNA clone of the rat mRNA encoding cyclophilin. *DNA.* 7:261–267.

Dianzani, U., V. Redoglia, F. Malavasi, M. Bragardo, A. Pileri, C. A. Janeway, and K. Bottomly. 1992. Isoform-specific association of CD45 with accessory molecules in human T lymphocytes. *Eur. J. Immunol.* 22:365–371.

Doherty, P., and F. S. Walsh. 1994. Signal transduction events underlying neurite outgrowth stimulated by cell adhesion molecules. *Curr. Opin. Neurobiol.* 4:49–55.

Doherty, P., C. E. C. K. Moolenaar, S. V. Ashton, R. J. A. M. Michalides, and F. S. Walsh. 1992. Use of the VASE exon down regulates the neurite outgrowth promoting activity of NCAM 140. *Nature (Lond.).* 356:791–793.

Edelman, G. M., and K. L. Crossin. 1991. Cell adhesion molecules: Implications for a molecular histology. 1991. *Annu. Rev. Biochem.* 60:155–190.

Fischer, E. H., H. Charbonneau, and N. K. Tonks. 1991. Protein tyrosine phosphatases: a diverse family of intracellular and transmembrane enzymes. *Science (Wash. DC).* 253:401–406.

Foley, K. P., M. W. Leonard, and J. D. Engel. 1993. Quantitation of RNA using the polymerase chain reaction. *Trends Genet.* 9:380–385.

Frei, T., F. von Bohlen und Halbach, W. Wille, and M. Schachner. 1992. Different extracellular domains of the neural cell adhesion molecule (N-CAM) are involved in different functions. *J. Cell Biol.* 118:177–194.

Gebbink, M. F. B. G., I. van Etten, G. Hateboer, R. Suijkerbuijk, R. L. Beijersbergen, A. G. van Kessel, and W. H. Moolenaar. 1991. Cloning, expression and chromosomal localization of a new putative receptor-like protein tyrosine phosphatase. *FEBS (Fed. Eur. Biochem. Soc.) Lett.* 290: 123–130.

Gebbink, M. F. B. G., G. C. M. Zondag, R. W. Wubbolts, R. L. Beijersbergen, I. van Etten, and W. H. Moolenaar. 1993. Cell-cell adhesion mediated by a receptor-like protein tyrosine phosphatase. *J. Biol. Chem.* 268: 16101–16104.

Genuardi, M., H. Tsihira, D. E. Anderson, and G. F. Saunders. 1989. Distal deletion of chromosome 1p in ductal carcinoma of the breast. *Am. J. Hum. Genet.* 45:73–82.

Gilliland, G., S. Perrin, K. Blanchard, and H. F. Bunn. 1990. Analysis of cytokine mRNA and DNA: Detection and quantitation by competitive polymerase chain reaction. *Proc. Natl. Acad. Sci. USA.* 87:2725–2729.

Goldberg, Y. P., S. E. Andrew, L. A. Clarke, and M. R. Hayden. 1993. A PCR method for accurate assessment of trinucleotide repeat expansion in Huntington disease. *Hum. Molec. Genet.* 2:635–636.

Gower, H. J., C. H. Barton, V. L. Elsom, J. Thompson, S. E. Moore, G. Dickson, and F. S. Walsh. 1988. Alternative splicing generates a secreted form of N-CAM in muscle and brain. *Cell.* 55:955–964.

Harlow, E. and D. Lane. 1988. *Antibodies: A Laboratory Manual.* Cold Spring Harbor Laboratory, Cold Spring Harbor, NY. 726 pp.

Ignelzi, M. A., D. R. Miller, P. Soriano, and P. F. Maness. 1994. Impaired neurite outgrowth of *src*-minus cerebellar neurons on the cell adhesion molecule L1. *Neuron.* 12:873–884.

Ip, N. Y., C. F. Ibanez, S. H. Nye, J. McClain, P. F. Jones, D. R. Gies, L. Belluscio, M. M. Le Beau, R. Espinosa, S. P. Squinto, H. Persson, and G. D. Yancopoulos. 1992. Mammalian neurotrophin-4: structure, chromosomal localization, tissue distribution, and receptor specificity. *Proc. Natl. Acad. Sci. USA.* 89:3060–3064.

Jacobson, M. 1978. *Developmental Neurobiology.* Plenum Press, New York. 181–210.

Jansen, G., M. Mahadevan, C. Amemiya, N. Wormskamp, B. Segers, W. Hendriks, K. O'Hoy, S. Baird, L. Sabourin, G. Lennon, P. L. Jap, D. Iles, M. Coerwinkle, M. Hofker, A. V. Carrano, P. J. de Jong, R. G. Corneluk, and B. Wieringa. 1992. Characterization of the myotonic dystrophy region predicts multiple protein isoform-encoding mRNAs. *Nature Genet.* 1: 261–266.

Jiang, Y.-P., H. Wang, P. D'Eustachio, J. M. Musacchio, J. Schlessinger, and J. Sap. 1993. Cloning and characterization of R-PTP- κ , a new member of the receptor protein tyrosine phosphatase family with a proteolytically cleaved cellular adhesion molecule-like extracellular region. *Mol. Cell Biol.* 13:2942–2951.

Jirik, F. R., K. W. Harder, I. G. Melhado, L. L. Anderson, and A. M. Duncan. 1992. The gene for leukocyte antigen-related tyrosine phosphatase (LAR) is localized to human chromosome 1p32, a region frequently deleted in tumors of neuroectodermal origin. *Cytogenet. Cell Genet.* 61:266–268.

Kimmel, D. W., J. R. O'Fallon, B. W. Scheithauer, P. J. Kelly, G. W. Dewald, and R. B. Jenkins. 1992. Prognostic value of cytogenetic analysis in human cerebral astrocytomas. *Ann. Neurol.* 31:534–542.

Krueger, N. X., M. Streuli, and H. Saito. 1990. Structural diversity and evolution of human receptor-like protein tyrosine phosphatases. *EMBO (Eur. Mol. Biol. Organ.) J.* 9:3241–3252.

Li, S.-H., M. G. McInnis, R. L. Margolis, S. E. Antonarakis, and C. A. Ross. 1993. Novel triplet repeat containing genes in human brain: cloning, expression, and length polymorphisms. *Genomics.* 16:572–579.

Longo, F. M., J. A. Martignetti, J. M. Le Beau, J. S. Zhang, J. P. Barnes, and J. Brosius. 1993. Leukocyte common antigen-related receptor-linked tyrosine phosphatase. Regulation of mRNA expression. *J. Biol. Chem.* 268:26503–26511.

Luna, E. J., and A. L. Hitt. 1992. Cytoskeleton-plasmid membrane interactions. *Science (Wash. DC).* 258:955–964.

- Magal, E., P. Burnham, and S. Varon. 1991. Effect of CNTF on low-affinity NGF receptor expression by cultured neurons from different rat brain regions. *J. Neurosci. Res.* 30:560-566.
- Maher, P. A. 1993. Activation of phosphotyrosine phosphatase activity by reduction of cell-substrate adhesion. *Proc. Natl. Acad. Sci. USA.* 90:11177-11181.
- Martin, J. B. 1993. Molecular genetics of neurological diseases. 1993. *Science (Wash. DC)*. 262:674-675.
- Mathew, C. G. P., B. A. Smith, K. Thorpe, Z. Wong, N. J. Royle, A. J. Jeffreys, and B. A. J. Ponder. 1987. Deletion of genes on chromosome 1 in endocrine neoplasia. *Nature (Lond.)*. 328:524-526.
- Matten, W. T., M. Aubry, J. West, and P. F. Maness. 1990. Tubulin is phosphorylated at tyrosine by pp60 c-src in nerve growth cone membranes. *J. Cell Biol.* 111:1959-1970.
- Mauro, L. J., and J. E. Dixon. 1994. 'Zip codes' direct intracellular protein tyrosine phosphatases to the correct cellular 'address.' *Trends Biochem. Soc.* 19:131-135.
- Michie, C. A., A. McLean, C. Alcock, and P. C. L. Beverley. 1992. Lifespan of human lymphocyte subsets defined by CD45 isoforms. *Nature (Lond.)*. 360:264-265.
- Miwa, S. 1994. Triplet repeats strike again. *Nature Genet.* 6:3-4.
- Mizuno, K., K. Hasegawa, T. Katagiri, M. Ogimoto, T. Ichikawa, and H. Yakura. 1993. MPTP δ , a putative murine homolog of HPTP δ , is expressed in specialized regions of the brain and in the B-cell lineage. *Mol. Cell. Biol.* 13:5513-5523.
- Mobley, W. C., J. L. Rutkowski, G. I. Tennekoon, J. Gemski, K. Buchanan, and M. V. Johnston. 1986. Nerve growth factor increases choline acetyltransferase activity in developing basal forebrain neurons. *Mol. Brain Res.* 1:53-62.
- Moley, J. F., M. B. Brother, C-T. Fong, P. S. White, S. B. Baylin, B. Nelkin, S. A. Wells, and G. M. Brodeur. 1992. Consistent association of 1p loss of heterozygosity with pheochromocytomas from patients with multiple endocrine neoplasia type 2 syndromes. *Cancer Res.* 52:770-774.
- Nieke, J., and M. Schachner. 1985. Expression of the neural cell adhesion molecules N-CAM and L1 and their common carbohydrate epitope L2/HNK-1 during development and regeneration of sciatic nerve. *Differentiation.* 30:141-151.
- O'Grady, P., N. X. Krueger, M. Streuli, and H. Saito. 1994. Genomic organization of the human LAR protein tyrosine phosphatase gene and alternative splicing in the extracellular fibronectin type-III domains. 269:25193-25199.
- Pallen, C. J., and P. H. Tong. 1991. Elevation of membrane tyrosine phosphatase activity in density-dependent growth-arrested fibroblasts. *Proc. Natl. Acad. Sci. USA.* 88:6996-7000.
- Pan, M.-G., C. Rim, K. P. Lu, T. Florio, and P. J. S. Stork. 1993. Cloning and expression of two structurally distinct receptor-linked protein-tyrosine phosphatases generated by RNA processing from a single gene. *J. Biol. Chem.* 268:19284-19291.
- Patthy, L. 1990. Homology of a domain of the growth hormone/prolactin receptor family with type III modules of fibronectin. *Cell.* 61:13-14.
- Penninger, J. M., V. A. Wallace, K. Kishihara, and T. W. Mak. The role of p56^{lck} and p59^{lyn} tyrosine kinases and CD45 protein tyrosine phosphatases in T-cell development and clonal selection. *Immunol. Rev.* 135:183-214.
- Pot, D. A., T. A. Woodford, E. Remboutsika, R. S. Haun, and J. E. Dixon. 1991. Cloning, bacterial expression, purification, and characterization of the cytoplasmic domain of rat LAR, a receptor-like protein tyrosine phosphatase. *J. Biol. Chem.* 266:19688-19696.
- Reichardt, L. F., and K. J. Tomaselli. 1991. Extracellular matrix molecules and their receptors: functions in neural development. *Annu. Rev. Neurosci.* 14:531-570.
- Richards, R. I., and G. R. Sutherland. 1992. Dynamic mutations: a new class of mutations causing human disease. *Cell.* 70:709-712.
- Richards, R. I., and G. R. Sutherland. 1994. Simple repeat DNA is not replicated simply. *Nature Genet.* 6:114-116.
- Riggins, G. J., L. K. Lokey, J. L. Chastain, H. A. Leiner, S. L. Sherman, K. D. Wilkinson, and S. T. Warren. 1992. Human genes containing polymorphic trinucleotide repeats. *Nature Genet.* 2:186-191.
- Ritke, M. K., R. Shah, M. Valentine, E. C. Douglass, and A. Tereba. 1989. Molecular analysis of chromosome 1 abnormalities in neuroblastoma. *Cytogenet. Cell Genet.* 50:84-90.
- Rutishauser, U. 1993. Adhesion molecules of the nervous system. *Curr. Opin. Neurobiol.* 3:709-715.
- Sahin, M., and S. Hockfield. 1993. Protein tyrosine phosphatase expressed in the developing rat brain. *J. Neurosci. Res.* 13:4968-4978.
- Sambrook, J., E. F. Fritsch, and T. Maniatis. 1989. *Molecular Cloning: A Laboratory Manual*. Second Edition. Cold Spring Harbor Laboratory. Cold Spring Harbor, New York.
- Sap, J., Y.-P. Jiang, D. Friedlander, M. Grumet, and J. Schlessinger. 1994. Receptor tyrosine phosphatase R-PTP- κ mediates homophilic binding. *Mol. Cell. Biol.* 14:1-9.
- Satterwhite, L. L., M. J. Lohka, K. L. Wilson, T. Y. Scherson, L. J. Cisek, J. L. Corden, and T. D. Pollard. 1992. Phosphorylation of myosin-II regulatory light chain by cyclin-p34^{cdc2}: a mechanism for the timing of cytokinesis. *J. Cell Biol.* 118:595-605.
- Schraven, B., Y. Samstag, P. Altevogt, and S. C. Meuer. 1990. Association of CD2 and CD45 on human T lymphocytes. *Nature (Lond.)*. 345:71-74.
- Schubert, D., S. Heinemann, and Y. Kidokoro. 1977. Cholinergic metabolism and synapse formation by a rat nerve cell line. *Proc. Natl. Acad. Sci. USA.* 74:2579-2583.
- Small, S. J., and R. Akeson. 1990. Expression of the unique NCAM VASE exon is independently regulated in distinct tissues during development. *J. Cell Biol.* 111:2089-2096.
- Smith, C. W. J., J. G. Patton, and B. Nadal-Ginard. 1989. Alternative splicing in the control of gene expression. *Annu. Rev. Genet.* 23:527-577.
- Streuli, M., N. X. Krueger, L. R. Hall, S. F. Schlossman, and H. Saito. 1988. A new member of the immunoglobulin superfamily that has a cytoplasmic region homologous to the leukocyte common antigen. *J. Exp. Med.* 168:1523-1530.
- Streuli, M., N. X. Krueger, P. D. Ariniello, M. Tang, J. M. Munro, W. A. Blattler, D. A. Adler, C. M. Distche, and H. Saito. 1992. Expression of the receptor-linked protein tyrosine phosphatase LAR: proteolytic cleavage and shedding of the CAM-like extracellular region. *EMBO (Eur. Mol. Biol. Organ.) J.* 11:897-907.
- Tian, S.-S., P. Tsoulfas, and K. Zinn. 1991. Three receptor-linked protein-tyrosine phosphatases are selectively expressed on central nervous system axons in the *Drosophila* embryo. *Cell.* 67:675-685.
- Vogel, W., R. Lammers, J. Huang, and A. Ullrich. 1993. Activation of a phosphotyrosine phosphatase by tyrosine phosphorylation. *Science (Wash. DC)*. 259:1611-1614.
- Walton, K. M., and J. E. Dixon. 1993. Protein tyrosine phosphatases. *Annu. Rev. Biochem.* 62:101-120.
- Wang, A. M., M. V. Doyle, and D. F. Mark. 1989. Quantitation of mRNA by the polymerase chain reaction. *Proc. Natl. Acad. Sci. USA.* 86:9717-9721.
- Walton, K. M., K. J. Martell, S. P. Kwak, J. E. Dixon, and B. L. Largent. 1993. A novel receptor-type protein tyrosine phosphatase is expressed during neurogenesis in the olfactory neuroepithelium. *Neuron.* 11:387-400.
- Wells, R. D., and R. R. Sinden. 1993. Defined ordered sequence DNA, DNA structure, and DNA-directed mutation. In *Genome Rearrangement and Stability*. K. E. Davies and S. T. Warren, editors. Cold Spring Harbor Press, Cold Spring Harbor, NY. 107-138.
- Yan, H., A. Grossman, H. Wang, P. D'Eustachio, K. Mossie, J. M. Musacchio, O. Silvennoinen, and J. Schlessinger. 1993. A novel receptor tyrosine phosphatase- σ that is highly expressed in the nervous system. *J. Biol. Chem.* 268:24880-24886.
- Yu, Q., T. Lenardo, and R. A. Weinberg. 1992. The N-terminal and C-terminal domains of a receptor tyrosine phosphatase are associated by non-covalent linkage. *Oncogene.* 7:1051-1057.
- Zhang, W.-R., and B. J. Goldstein. 1991. Identification of skeletal muscle protein-tyrosine phosphatases by amplification of conserved cDNA sequences. *Biochem. Biophys. Res. Commun.* 178:1291-1297.
- Zheng, C.-J., B. Byers, and S. H. Moolgavkar. 1993. Allelic instability in mitosis: a unified model for dominant disorders. *Proc. Natl. Acad. Sci. USA.* 90:10178-10182.
- Zisch, A. H., L. D'Alessandri, B. Ranscht, R. Falchetto, K. H. Winterhalter, and L. Vaughan. 1992. Neuronal cell adhesion molecule contactin/F11 binds to tenascin via its immunoglobulin-like domains. *J. Cell Biol.* 119:203-213.