

THE PRESENCE OF BACTERIA IN THE LUNGS OF MICE
FOLLOWING INHALATION.

By ERNEST G. STILLMAN, M.D.

(From the Hospital of The Rockefeller Institute for Medical Research.)

(Received for publication, March 13, 1923.)

Considerable discussion has arisen at various times as to whether inspired bacteria reach the lungs or are filtered out in the nasal passages. After carefully reviewing the subject of elimination of bacteria from the respiratory tract, Bloomfield (1) concluded that in health and under average conditions of dust exposure microorganisms only occasionally penetrate below the larynx. He thinks that this result is chiefly due to the effective filtration system of the upper respiratory tract. Bacteria inspired into the upper respiratory tract, unless they incite disease, are eliminated by the ciliary currents, die *in situ*, or are carried off through the lymphatics. On the other hand, Jones (2) has recently shown that bacteria may be readily recovered from the borders of lungs removed from healthy calves, rabbits, guinea pigs, white rats, and mice. The microorganisms most frequently observed in cultures from the lungs of these normal animals were streptothrix, molds, and the bacteria of the *subtilis* group. Trillat and Kaneko (3) state that in mice, after 15 minutes of inhalation of a spray containing *Bacillus paratyphosus* and pneumococcus, these organisms are present in the pulmonary alveoli. They found that a much smaller number of paratyphoid bacilli were sufficient to cause infection in mice if they were administered by spraying than if they were mixed with the food or even injected subcutaneously. Wherry and Butterfield (4) have shown that pneumococci may be recovered from the deepest parts of the lungs of mice as long as 18 hours after spraying with a pneumococcus culture. Although they used a virulent Type I pneumococcus culture, none of the twenty-nine mice which were allowed to live, following the inhalation of the pneumococcus mist, became infected.

The purpose of the present study was to extend the above mentioned observations in the hope of obtaining further information concerning pulmonary infection under natural conditions.

Method.

Mice were used as the test animals. They were allowed to inhale an atmosphere in which a fine mist had been produced by spraying a culture of the organism to be studied. The organisms used were pneumococcus, *Streptococcus hæmolyticus*, *Bacillus influenzae*, and staphylococcus.

The animals were placed in a galvanized iron box 12 by 10 by 7 inches (Text-fig. 1). This box was provided with two glass windows

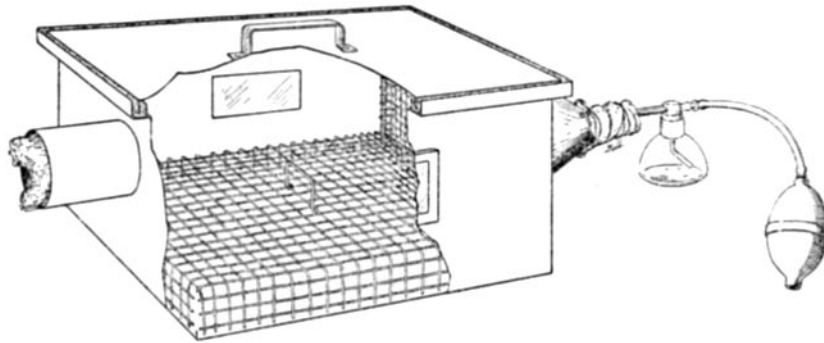

TEXT-FIG. 1. Spray box.

in the sides and an air vent in one end which was plugged with cotton. At the opposite end was an opening through which the nozzle of an atomizer was inserted. The lid of the box rested in a cotton-filled groove. Before each experiment the entire box was sterilized in an autoclave. After the animals had been placed in the box, 10 to 15 cc. of broth culture were sprayed into the box with a hand atomizer, 10 to 15 minutes continuous spraying being sufficient to fill the interior of the box with a heavy cloud of finely divided droplets. As a rule, the mice were removed from the spray box 1 hour after spraying. At various intervals following the spraying, individual mice were killed and cultures were made from the lungs and other organs. In order to prevent the possibility of aspiration of bacteria from the upper to the

lower respiratory tract at the time of death, the mice were killed instantaneously by clamping the trachea and spinal cord with sponge forceps. The mice were then immersed in a solution of lysol and opened with sterile instruments. As a routine procedure, cultures in broth were made from the heart's blood, the spleen, and the lungs. In making the cultures pieces of the spleen and small pieces of the lung tissue from the borders of the lower lobes were placed directly in tubes of broth. All cultures which subsequently grew were plated on blood agar for further identification. All cultures were incubated

TABLE I.
Recovery of Pneumococci, Hemolytic Streptococci, Influenza Bacilli, and Staphylococci from the Lungs of Mice after Exposure to an Atmosphere Containing Culture in the Form of Spray.

Culture.	No. of mice exposed.	No. of mice killed.	Results of cultures from lungs.										No. of mice not killed.	No. of mice dying with septicæmia.	No. of mice surviving.	
			Length of time following exposure.													
			1 hr.	2 hrs.	3 hrs.	4 hrs.	5 hrs.	6 hrs.	8 hrs.	12 hrs.	24 hrs.	48 hrs.				
Pneumococcus.....	12	6	+	+	-	-	-	-	-	-	-	-	-	6	1	5
<i>Streptococcus hæmolyticus</i>	12	6	+	+	+	+	+	+	+	+	+	+	+	6	6	0
<i>B. influenza</i>	10	6	+	-	+	+	+	-	-	-	-	-	-	4		4
<i>Staphylococcus aureus</i>	10	6	+	+	+	+	+	+	+	+	+	+	+	4		4

The pneumococcus and streptococcus cultures employed had a virulence such that 0.000001 cc. injected intraperitoneally into mice killed within 36 hours.

The cultures of *B. influenza* and *Staphylococcus aureus* had very little virulence on intraperitoneal injection.

for at least 36 hours. In a few instances growth was apparent only after 24 hours incubation. This was probably due to the small number of organisms present.

RESULTS.

In Table I is presented the protocol of one typical experiment. The total number of mice exposed to the atmosphere into which bacteria were sprayed was forty-four. Twelve of the mice were placed in a box into which a culture of pneumococcus was sprayed, twelve in a box into which a culture of *Streptococcus hæmolyticus* was

sprayed, ten in a box into which a culture of *Bacillus influenzae* was sprayed, and ten in a box into which a culture of *Staphylococcus aureus* was sprayed.

Of the twelve mice exposed to the air containing pneumococci in suspension, six were killed at varying intervals of time, up to 12 hours. In cultures from the lungs of the mice killed 1 and 2 hours after exposure, pneumococci developed, while the cultures from the lungs of the mice killed after 3, 5, 8, and 12 hours remained sterile. Cultures from the spleen and from the heart's blood of all these mice remained sterile. The remaining six mice were not killed but were kept under observation. One died on the 3rd day. No gross lesions of the lungs were present, but cultures showed a general infection with pneumococcus. The other five mice survived and were discarded at the end of 14 days.

Of the twelve mice exposed to the air containing streptococci in suspension, six were killed at the end of 1, 2, 3, 5, 8, and 12 hours, respectively. From the lungs of all these mice streptococci were cultivated, while the cultures from the spleen and heart's blood remained sterile in all cases. Of the remaining six mice which were not killed, all died between the 5th and 10th days and all were found to have a general streptococcus infection.

Ten mice were exposed to air containing influenza bacilli in suspension, and six of these were killed at the end of 1, 2, 3, 6, 24, and 48 hours, respectively. The results of the cultures from the lungs in these animals were irregular. From the lungs of the animals killed 1, 3, and 24 hours after spraying, influenza bacilli were cultivated, but the cultures from the lungs of those killed at the end of 2, 6, and 48 hours remained sterile. Cultures from the spleen and heart's blood remained sterile in all instances. The remaining four mice of this group were kept under observation for 10 days and all remained well.

Ten mice were exposed to air containing staphylococci in suspension. Six were killed at varying intervals, and from the lungs of the animals killed 1, 3, 4, and 6 hours after spraying, staphylococci were cultivated, while the cultures from the mice killed 24 and 48 hours after spraying remained sterile. All cultures from the heart's blood and spleen remained sterile. The remaining four mice of this group were not killed but were kept under observation for 10 days. All remained well.

This experiment demonstrates that under the conditions employed, when mice are allowed to breathe an atmosphere in which bacteria have been suspended by spraying, the bacteria reach the lungs and may be found there for considerable periods of time following the spraying. The period during which their presence in the lung may be demonstrated, however, apparently varies with different bacteria. Pneumococci were not found after 3 hours, while streptococci, influenza bacilli, and staphylococci were present after longer intervals. Following inhalation of pneumococcus, only one of the animals which were not killed died later of a general infection, while all the animals exposed to streptococcus spray died later of a general streptococcus septicemia. None of the animals exposed to the *Bacillus influenzae* or staphylococcus spray suffered from a general fatal infection.

A number of experiments similar to the one described above have been carried out and the results in all instances have in general agreed with those described above. To avoid repetition, the results of all these experiments, including the one just described, have been combined. The total number of the mice exposed to the spray containing virulent Type I pneumococci was 228, those exposed to a spray containing virulent hemolytic streptococci was 45, and those exposed to a spray containing influenza bacilli was 32. No experiments other than that mentioned above have been carried out with staphylococci.

The results of these combined experiments, as far as the animals killed following exposure to the infected spray are concerned, are shown in Text-fig. 2. Of the 228 mice exposed to the spray containing pneumococci, thirty-seven were killed at varying intervals, and the results of the study of these thirty-seven mice are shown on the chart. It is seen that pneumococci were found to be present in the lungs of all of the fifteen mice killed within 2 hours of the exposure. Of four animals killed 3 hours after the exposure, pneumococci were demonstrated in the lungs in three instances, and the cultures from the lungs were negative in one. Of the eighteen mice killed after 3 hours, in the lungs of none could pneumococci be demonstrated. The remaining 191 mice of those exposed, were not killed but were kept under observation for at least 10 to 14 days. Twenty of these mice died, but in sixteen instances the cause of death was not due to pneumococcus infection, as in fourteen the cultures were sterile, and

Of the forty-five mice exposed to the spray containing streptococci, twenty-one were killed, and the results of the cultures from the lungs in these mice are also shown in Text-fig. 2. It will be seen that of seventeen mice killed before the 12th hour following exposure, streptococci were demonstrated to be present in the lungs of all, and in one mouse killed after 24 hours streptococci were also cultivated from the lungs. In the three other mice, one killed after 20 hours and two after 48 hours, the cultures from the lungs remained sterile. The remaining twenty-four mice of the streptococcus series were not killed but were kept under observation. In striking contrast to the mice exposed to pneumococcus spray, seventeen, or 70 per cent, of these mice died between the 2nd and 12th days, and all suffered from a general streptococcus infection. Only seven mice were living at the end of 14 days.

Of the total thirty-two mice exposed to the spray containing influenza bacilli, seventeen were killed. Again the results of lung culture are shown in Text-fig. 2. It is obvious that here the results are irregular, in some instances the cultures from the lungs being positive and in others negative, both in animals killed soon after exposure and in others killed after much longer periods. The fifteen mice which were not killed were kept under observation for 14 days and none died during this period.

DISCUSSION.

The results obtained by combining all the experiments support the correctness of the previous observations. That during exposure of mice to a dense spray containing bacteria in suspension, the bacteria reach the lungs, seems to be demonstrated. The exact degree of penetration is as yet uncertain, but as the bacteria can be grown from very minute portions of lung tissue removed from the periphery, it seems safe to conclude that the bacteria reach the finer bronchi at least.

The further history of the bacteria which have penetrated the lungs seems to depend upon the variety of microorganism concerned. As regards pneumococcus, the bacteria are disposed of within a few hours. On the question as to whether they are killed *in situ*, are taken up by leucocytes, or are carried to other parts of the body, the present experiments throw no light. Streptococci, on the other hand,

at least with the cultures employed in these experiments, persist in the lungs for a much longer period of time. This fact may be associated with the occurrence of true infection, as subsequent events in many of these animals indicate. The results of the experiments in which *Bacillus influenzae* was employed were more irregular; apparently sometimes these bacteria remain in the lungs for considerable periods of time, in other instances they disappear very quickly. Whether this result is associated with failure of the bacteria to penetrate deeply, or is related to the difficulty of cultivation of this organism, is not certain.

The fact that the penetration of the lungs by streptococci is usually followed by a general infection, while pneumococci are disposed of without any general infection resulting has been somewhat surprising. This was especially so in view of the fact that the virulence of the pneumococcus culture employed, as tested by intraperitoneal injection into mice, was equal to that of the streptococcus culture.

It was suggested that the apparent lack of invasiveness of the inhaled pneumococci might depend upon an insufficient number of organisms reaching the lung. That this view, however, is not tenable is shown by the following experiment. Six mice were exposed to an atmosphere containing pneumococci in suspension as previously described, and after 1 hour had elapsed all were killed. A single lobe of one lung was removed from each of the mice and each lobe was ground up separately in a mortar with sterile sand and normal salt solution. The supernatant fluid was then used for inoculation intraperitoneally into six normal mice. Five of the six mice injected died within 48 hours with a general pneumococcus infection. One mouse survived. It is evident, therefore, that in most instances pneumococci reach the lung in sufficient numbers to cause infection provided other conditions are favorable. It seems probable that normally the conditions in the lungs of mice are unfavorable for infection with pneumococci, even when the number of organisms reaching the lower respiratory tract is considerable. It is true that Blake and Cecil (5) infected monkeys with pneumococci by injecting minute amounts of the culture into the trachea, but even in these experiments a relatively considerable amount of fluid (1 cc.) was injected. The relation of the

injury produced by the penetration of the needle through the skin and tracheal mucous membrane to the subsequent infection should also be borne in mind.

In any case the present experiments indicate that in mice at least the mere presence of pneumococci in the lungs is not sufficient to induce infection, but that other factors are also concerned. An attempt has been made to discover something of the nature of these other factors by exposing the mice to altered external conditions before exposing them to the atmosphere of the spray box. The effects of sudden chilling and exposure to cold were studied. Mice were chilled before being placed in the spray box, others were kept chilled while they were in the box, and still others were chilled after the exposure in the box had taken place. They were chilled by being dipped into ice water, placed in an ice box, sprayed with cold water, or allowed to stand in melting snow. None of these procedures resulted in so changing conditions that infection occurred with any greater frequency than in the controls.

Attempts to lower local resistance by inducing slight injuries to the mucous membrane were also made. These attempts consisted in allowing animals to inhale ether before or after exposure to the spray, and certain mice were also exposed to an atmosphere containing finely divided quartz sand or talc in the form of dust before or following the exposure. These experiments also resulted in failure to increase the frequency of infection.

The present experiments, therefore, fail to shed any light on the exact mode of natural infection of the lung with pneumococci. They indicate that even in so susceptible an animal as the mouse other factors than the presence of the pneumococci in the lung are necessary for infection.

CONCLUSIONS.

1. When mice are exposed to an atmosphere containing cultures of bacteria in the form of a fine mist, the bacteria readily penetrate into the lower respiratory tract.
2. Pneumococci which have reached the lung as a result of this procedure usually disappear within a few hours and give rise to no

infection. Hemolytic streptococci, on the other hand, persist in the lung for a considerably longer time and a general septicemia usually follows.

3. Attempts to determine the conditions under which pneumococci which have reached the lung by inhalation may induce a local or general infection have not been successful.

BIBLIOGRAPHY.

1. Bloomfield, A. L., *Am. J. Med. Sc.*, 1922, clxiv, 854.
2. Jones, F. S., *J. Exp. Med.*, 1922, xxxvi, 317.
3. Trillat, A., and Kaneko, R., *Compt. rend. Acad.*, 1921, clxxiii, 109.
4. Wherry, W. B., and Butterfield, C. T., *J. Infect. Dis.*, 1920, xxvii, 315.
5. Blake, F. G., and Cecil, R. L., *J. Exp. Med.*, 1920, xxxi, 403.