

In Vivo Evidence That the Stromelysin-3 Metalloproteinase Contributes in a Paracrine Manner to Epithelial Cell Malignancy

Régis Masson,* Olivier Lefebvre,* Agnès Noël,‡ Mostapha El Fahime,* Marie-Pierre Chenard,|| Corinne Wendling,* Florence Kebers,‡ Marianne LeMeur,* Andrée Dierich,* Jean-Michel Foidart,‡ Paul Basset,* and Marie-Christine Rio*

*Institut de Génétique et de Biologie Moléculaire et Cellulaire, Centre National de la Recherche Scientifique, Institut National de la Santé et de la Recherche Médicale, Université Louis Pasteur, BP 163, 67404 Illkirch Cedex, C.U. de Strasbourg, France;

‡Laboratoire de Biologie des Tumeurs et du Développement, University of Liège, 4000 Sart-Tilman, Liège, Belgium; and

||Service d'Anatomie Pathologique Générale, Hôpital de Hautepierre, Hôpitaux Universitaires de Strasbourg, 67098 Strasbourg Cedex, France

Abstract. Stromelysin-3 (ST3; Basset, P., J.P. Bellocq, C. Wolf, I. Stoll, P. Hutin, J.M. Limacher, O.L. Podhajcer, M.P. Chenard, M.C. Rio, P. Chambon. 1990. *Nature*. 348:699–704) is a matrix metalloproteinase (MMP) expressed in mesenchymal cells located close to epithelial cells, during physiological and pathological tissue remodeling processes. In human carcinomas, high ST3 levels are associated with a poor clinical outcome, suggesting that ST3 plays a role during malignant processes. In this study we report the ST3 gene inactivation by homologous recombination. Although ST3 null mice (ST3^{-/-}) were fertile and did not exhibit obvious alterations in appearance and behavior, the lack of ST3 altered malignant processes. Thus, the suppression

of ST3 results in a decreased 7,12-dimethylbenzanthracene-induced tumorigenesis in ST3^{-/-} mice. Moreover, ST3^{-/-} fibroblasts have lost the capacity to promote implantation of MCF7 human malignant epithelial cells in nude mice ($P < 0.008$). Finally, we show that this ST3 paracrine function requires extracellular matrix (ECM)-associated growth factors. Altogether, these findings give evidence that ST3 promotes, in a paracrine manner, homing of malignant epithelial cells, a key process for both primary tumors and metastases. Therefore, ST3 represents an appropriate target for specific MMP inhibitor(s) in future therapeutic approaches directed against the stromal compartment of human carcinomas.

STROMELYSIN-3 (ST3¹; Basset et al., 1990) is a secreted protein that belongs to the matrix metalloproteinase (MMP) family (Birkedal-Hansen, 1995). This family of extracellular zinc-dependent endopeptidases currently has at least 17 members, with enzymatic activity against virtually all components of the ECM (Coussens and Werb, 1996; Basset et al., 1997a). However, mature forms of human ST3 appear unable to degrade any major ECM component (Pei et al., 1994; Noël et al., 1995). Furthermore, ST3 was shown to be predominantly secreted in a potentially active form whereas other secreted MMPs must be activated extracellularly (Pei and Weiss, 1995). Together, these findings suggest that, among MMPs, ST3 may have a unique role.

Address correspondence to Marie-Christine Rio, Institut de Génétique et de Biologie Moléculaire et Cellulaire, CNRS/INSERM/ULP, BP 163, 67404 Illkirch Cedex, C.U. de Strasbourg, France. Tel.: (33) 3 88 65 34 24. Fax: (33) 3 88 65 32 01.

1. *Abbreviations used in this paper:* DMBA, 7,12-dimethylbenzanthracene; ECM, extracellular matrix; ES, embryonic stem; Gel A, gelatinase A; MMP, matrix metalloproteinase; ST3, stromelysin-3; TPA, 12-*O*-tetradecanoylphorbol 13-acetate.

ST3 is expressed in some physiological conditions associated with intense tissue remodeling including embryonic implantation and subsequent embryonic development (Lefebvre et al., 1995). Strong expression notably occurs during neurogenesis, osteogenesis, and embryonic limb, tail, and snout morphogenesis. Similar observations were made for tail resorption during amphibian metamorphosis (Wang and Brown, 1993; Patterton et al., 1995). In adult tissues, ST3 expression is observed during the postweaning involution of the mammary gland (Lefebvre et al., 1992), the postpartum involution of the uterus (our unpublished data), in cycling endometrium (Rodgers et al., 1994), and in the placenta (Basset et al., 1990; Maquoui et al., 1997). ST3 expression was also observed during skin wound healing (Wolf et al., 1992; Okada et al., 1997) and bone repair (our unpublished data). At the cellular level, ST3 is detected in cells of mesenchymal origin, predominantly in fibroblasts located in the vicinity of epithelial cells (Lefebvre et al., 1992; Lefebvre et al., 1995; Okada et al., 1997). These observations suggest that ST3 is a connective tissue-derived factor that may play a role during organogenesis and in the homeostasis of epithelial cell compartments.

Ectopic ST3 expression is also observed in fibroblastic cells of most types of human carcinomas, including lung, skin, colon, head, and neck (Rouyer et al., 1994). Strong ST3 gene expression has been correlated with both increased local aggressiveness of tumors (Wolf et al., 1992; Muller et al., 1993; Porte et al., 1995) and a poor clinical outcome (Engel et al., 1994; Chenard et al., 1996).

In this study, we have cloned and disrupted the ST3 gene using the homologous recombination method. ST3-deficient mice (ST3^{-/-}) exhibit no particular phenotype. However, 7,12-dimethylbenzanthracene (DMBA)-induced tumorigenesis is strongly reduced in ST3^{-/-} mice, and ST3^{-/-} fibroblasts have lost the capacity to promote malignant cell implantation in nude mice. In addition, we demonstrate that this paracrine function of fibroblastic ST3 on malignant epithelial cells is dependent on ECM-associated growth factor(s).

Materials and Methods

Cloning of the Mouse ST3 Gene

50 µg of genomic DNA, extracted from mouse 129/Svj D3 embryonic stem (ES) cells, was partially digested with Sau3A. After size selection on a 10–30% sucrose gradient, fragments (16–20 kb) were subcloned at the BamHI replacement site in the λ EMBL 301. Recombinant clones (2.5 × 10⁶) were obtained and the library was amplified once. This library (500,000 plaque-forming units) was screened using a mouse ST3 cDNA probe (nucleotides 179–1505; Lefebvre et al., 1992). Six positive clones were subcloned into the pBluescript II (pBSII) vector, sequenced and positioned with respect to the mouse ST3 cDNA sequence (Lefebvre et al., 1992).

Construction of a Mouse ST3 Gene Targeting Replacement Vector

A 3' EcoRI genomic fragment (5.2 kb) containing the ST3 exons 2 to 7 was subcloned into the EcoRI site of the pBSII vector. Then, a 1.3-kb BglIII–BamHI PGK-neo fragment (without poly(A) signal) encoding the neo resistance gene was inserted at the unique BglIII site located in exon 7. After this insertion the 3' BamHI–BglIII restriction site was lost. Finally, the DNA fragment extending from the BamHI site of the pBSII vector to the remaining BglIII site was removed and replaced by a BamHI genomic ST3 fragment (6.3 kb) containing exon 1. We note that the 5' BamHI site of this fragment was created during the library construction, and subsequently is absent in the targeted ST3 gene. As previously, the 3' BamHI–BglIII insertion led to an inactive restriction site. The resulting construct was BamHI linearized (see Fig. 1) before electroporation in 129/Svj D3 ES cells (Lufkin et al., 1991).

ES Cell Transfection and Selection

ES cell electroporation, culture and G418 selection were performed as previously described (Lufkin et al., 1991). The ES clones were analyzed by Southern blot. SpeI-digested genomic DNA was fractionated by electrophoresis on 1% agarose gel, blotted onto Hybond N⁺ membranes (Amersham Corp., Arlington Heights, IL) and hybridized with the *P* probe corresponding to an EcoRI–SpeI restriction fragment of the mouse ST3 gene (0.36 kb), located 3' to the ST3 targeting construct (see Fig. 1). Hybridization and washing conditions were performed as described below for Northern blot analysis.

Generation of ST3-deficient Mice

Generation of chimeric mice, using C57BL/6J blastocysts and pseudogestante females, was performed as previously described (Gossler et al., 1986). Chimeric animals were mated with 129/Svj mice in order to generate heterozygote and, subsequently, homozygote animals. Mice with either C57BL/6J, BALB/c, or 129/Svj genetic background were thereafter obtained by back-crossing with adequate animals. Mouse genotyping was performed as described above, on genomic DNA extracted from tail materials as in Lufkin et al. (1991).

RNA Isolation and Northern Blot Analysis

Total RNA prepared by a single-step method using guanidinium isothiocyanate (Chomczynski and Sacchi, 1987) was fractionated by electrophoresis on 1% agarose gels in the presence of formaldehyde and transferred to nylon Hybond N membranes (Amersham Corp.). Hybridization conditions were as in Lefebvre et al. (1992). The mouse ST3 (nucleotides 179–1505) and gelatinase A (Gel A) cDNA probes were ³²P-labeled (10⁶ cpm/ng DNA). Hybridization was for 8 h at 42°C under stringent conditions (50% formamide, 5× SSC, 0.1% SDS, 0.1% polyvinylpyrrolidone, 0.1% Ficoll, 20 mM sodium pyrophosphate, 10% dextran sulfate, and 100 µg/ml ssDNA). Filters were washed for 30 min in 2× SSC, 0.1% SDS at room temperature, followed by 30 min in 0.1× SSC, 0.1% SDS at 55°C.

Whole Mount RNA In Situ Hybridization

Limb buds from 14.5 d post-coitum embryos were fixed in paraformaldehyde 4%, dehydrated in methanol and frozen at –20°C. They were then rehydrated, bleached with 6% hydrogen peroxide in PBT (1× PBS, 0.1% Tween 20), and proteinase K treated for 5–10 min at 37°C. After washing in PBT containing 2 mg/ml glycine, they were fixed in PBT containing 0.2% glutaraldehyde and 4% paraformaldehyde, prehybridized for 1 h at 65°C in hybridization mix (50% formamide, 5× SSC, 0.1 mg/ml yeast tRNA, 1% SDS, 50 µg/ml heparin) and hybridized for 12 h in hybridization mix containing 1 mg/ml digoxigenin-labeled sense or antisense mouse ST3 cDNA (nucleotides 179–1505; DIG RNA Labeling Kit; Boehringer Mannheim Corp., Indianapolis, IN). Washing was carried out as follows: 2× 30 min in solution 1 (50% formamide, 5× SSC, and 1% SDS) at 65°C; 10 min in solution 1/solution 2 (0.5 M NaCl, 10 mM Tris-HCl, pH 7.5, and 0.1% Tween 20) 1:1; 3× 5 min in solution 2; 2× 30 min in solution 2 containing 0.1 µg/ml RNase A at 37°C. After a rapid washing at room temperature in solution 2 and solution 3 (50% formamide, 2× SSC), the samples were incubated for 2× 30 min in solution 3 at 65°C. Detection was performed by using a polyclonal sheep antidigoxigenin Fab fragment, conjugated with alkaline phosphatase (DIG Nucleic Acid Detection Kit; Boehringer Mannheim Corp.).

DMBA-induced Tumorigenesis

ST3^{-/-} and ST3^{+/+} littermates of the 129/Svj genetic background were given weekly 500-µg doses of DMBA (Sigma Chemical Co.) diluted in corn oil (200 µl), by intragastric intubation, for 6 consecutive weeks beginning at 8 wk of age. 22 wk after the arrest of treatment surviving animals were killed and analyzed for the presence of tumors.

Primary Culture of ST3^{+/+} and ST3^{-/-} Embryonic Fibroblasts

ST3^{+/+} and ST3^{-/-} fibroblasts were generated by outgrowth of 15 d post-coitum mouse embryos obtained from mating either C57BL/6J/129/Svj (F2ST3^{+/+}, F9ST3^{+/+}, F1ST3^{-/-}, and F6ST3^{-/-}) or 129/Svj (F55ST3^{+/+}, F56ST3^{+/+}, F34ST3^{-/-}, and F44ST3^{-/-}) ST3^{+/+} animals, as in Loo et al. (1990). Cells were grown in DME supplemented with 10% fetal calf serum, glutamine (292 mg/ml), ascorbic acid (50 mg/ml), penicillin-streptomycin (100 mg/ml), and used between passages 2 and 6. Consistent with the neo gene integration in the targeting construct, the ST3^{-/-} but not the ST3^{+/+} cultures were resistant to the addition of 400 mg/ml G418 to the culture media. Cell proliferation was evaluated every 2 d by [³H]thymidine incorporation assay.

Tumorigenicity Assay in Nude Mice

Cultures of subconfluent MCF7 human breast cancer cells and of ST3^{+/+} and ST3^{-/-} mouse embryonic fibroblasts were trypsinized and centrifuged at 1,000 g for 5 min. Cells were resuspended in cold serum-free DME and mixed with an equal volume of cold matrigel (10 mg/ml) prepared from the Engelbreth-Holm-Swarm tumor, as previously described (Noël et al., 1993). Growth factor-depleted matrigel was prepared using ammonium sulfate as previously described (Taub et al., 1990). In each experiment, a total volume of 0.4 ml containing either 2 × 10⁵ MCF7 cells alone or 2 × 10⁵ MCF7 cells and 8 × 10⁵ ST3^{+/+} or ST3^{-/-} fibroblasts was subcutaneously injected into four 6–8-wk-old female nude mice (BALB/c nu/nu; Charles River Laboratories, Wilmington, MA), previously implanted with Silastic capsules (Dow Corning, Midland, MI) containing estradiol (Noël et al., 1993). Injected mice were examined every 2 d for tumor apparition,

and mean tumor volume was calculated as previously described (Noël et al., 1993). Differences between the experimental conditions were evaluated using Student's *t* test. *P* values <0.01 were considered significant. Tumor latency was defined as the number of days after cell injection necessary to obtain 50 or 100% tumors of at least 80 mm³ at the injection sites. ST3^{+/+} or ST3^{-/-} fibroblasts injected alone did not give tumors, indicating that they were not transformed.

Histological Analysis of Mice and Tumors

All mice were autopsied. Tissues and tumors were fixed in phosphate-buffered formalin (4%) and embedded in paraffin. Histological examination was performed on hematoxylin–eosin-stained sections.

Results

Generation of ST3-deficient Mice

The mouse ST3 gene (see cloning in Materials and Methods) encompasses 9.3 kb and contains, as its human counterpart (Anglard et al., 1995), 8 exons and 7 introns (Fig. 1 A). Exon 1 encodes the NH₂-terminal signal peptide, exon 2 the pro-domain, exons 3 to 6 the catalytic domain, and exons 7 and 8 the COOH-terminal hemopexin-like domain. Exon 8 also encodes the 3' untranslated region. In the targeting construct, exons 2 to 7 were deleted and replaced by the neomycin resistance gene (*neo*). The targeting construct contained 6.3 and 0.7 kb of DNA corresponding to the 5' and 3' parts of the mouse ST3 gene, respectively (Fig. 1 B). This construct was electroporated into 10⁷ ES cells, and DNA of 20 G418-resistant colonies was analyzed. One clone (YF14) showed a SpeI DNA restriction pattern consistent with the occurrence of homologous recombination (Fig. 1 C) in one of the mouse ST3 allele. No random integration of the target construct was detected in this clone using a *neo* probe (data not shown). The YF14 clone was microinjected into 300 C57BL/6J blastocysts, and 6 chimeric males were generated. One of them transmitted the mutated ST3 allele to its offspring and permitted to obtain heterozygous (ST3^{+/-}) and homozygous (ST3^{-/-}) mice (Fig. 1 D). Mice with either C57BL/6J, BALB/c or 129/Svj genetic background were thereafter obtained by back-crossing with adequate animals.

ST3 gene inactivation was tested by Northern blot analysis of total RNA extracted from 2 d involuting uteri of ST3^{+/+} control littermates, ST3^{+/-} and ST3^{-/-} mice. We observed the presence of 2.4 kb ST3 transcripts in the involuting uterus of the ST3^{+/+} and ST3^{+/-} mice (Fig. 2, lanes 3 and 4), but not of ST3^{-/-} mice (Fig. 2, lane 5). In contrast, the RNA for Gel A, another MMP, was detected in the three types of mice. ST3 and Gel A RNAs were absent and expressed at a low level in ST3^{+/+} and ST3^{-/-} virgin uterus, respectively (Fig. 2, lanes 1 and 2).

ST3^{-/-} Mice Exhibit No Obvious Phenotype

Genotyping of 80 3-wk-old offspring from ST3^{+/-} mouse crosses revealed a frequency of 30% ST3^{+/+} (*n* = 24), 50% ST3^{+/-} (*n* = 40), and 20% ST3^{-/-} (*n* = 16) mice. ST3^{-/-} mice were fertile, giving rise to an average of eight pups per litter, suggesting that there was no embryonic lethality. ST3^{+/-} and ST3^{-/-} mice were indistinguishable from ST3^{+/+} mice in appearance and behavior. These observations were valid for C57BL/6J, BALB/c and 129/Svj genetic

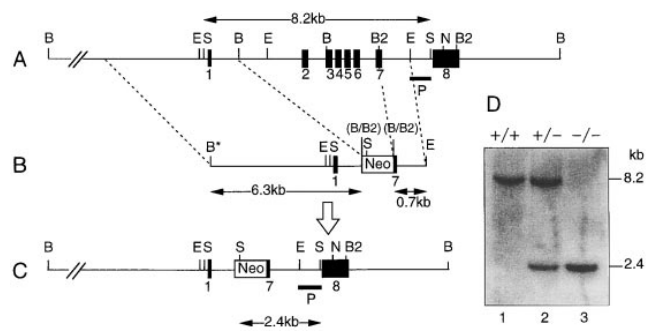

Figure 1. Targeted disruption of the mouse ST3 gene. (A) Structure of the mouse ST3 gene. (B) Structure of the mouse ST3 targeting construct. (C) Targeted mouse ST3 gene. Closed boxes represent exons. The *P* probe is indicated by an horizontal bar. Restriction sites: B, BamHI; B2, BglII; E, EcoRI; N, NsiI; S, SpeI; letter in parentheses indicates nonfunctional restriction sites; B* indicates a BamHI site that was generated during genomic library construction (see Materials and Methods). (D) Southern blot analysis of SpeI-digested genomic DNA extracted from tail of ST3^{+/+} (lane 1), ST3^{+/-} (lane 2) and ST3^{-/-} (lane 3) mice, and hybridized with the *P* probe. The wild-type (8.2 kb) and recombinant (2.4 kb) mouse ST3 DNA sizes are indicated.

backgrounds. Histological examination of various organs of ST3^{+/+} and ST3^{-/-} 2-mo-old mice did not show any significant difference for the brain, heart, lung, liver, pancreas, spleen, muscle, mammary gland, colon, ovary, uterus, and kidney (data not shown). Furthermore, histological analysis of tissues normally expressing the ST3 gene (Lefebvre et al., 1992, 1995; Wolf et al., 1992; Okada et al., 1997) was performed. No modification was observed during mammary gland and uterus involution, and development of 12 and 16 d post-coitum embryos (Fig. 3 and data not shown). Finally, no obvious abnormal repair was observed during skin wound healing and bone repair performed in ST3^{-/-} mice.

DMBA-induced Carcinomas in ST3^{+/+} and ST3^{-/-} Mice

ST3 is known to be strongly expressed in most human carcinomas (Rouyer et al., 1994). To investigate the effect of ST3 deficiency in malignant processes, we have chemically induced carcinomas in ST3^{-/-} mice. DMBA treatment

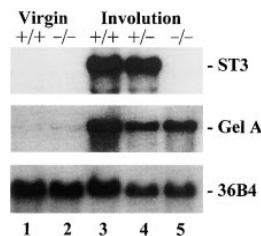

Figure 2. Northern blot analysis of mouse ST3 expression in 2 d postpartum involuting uterus of ST3^{+/+}, ST3^{+/-} and ST3^{-/-} mice. Each lane contained 10 µg of total RNA extracted from uterus of ST3^{+/+}, ST3^{+/-} or ST3^{-/-} mice. Lanes 1 and 2, uterus of virgin ST3^{+/+} and ST3^{-/-} mice were devoid of ST3 expression and exhibited a low level of Gel A expression. Lanes 3–5, ST3 transcripts were detected in ST3^{+/+} (lane 3) and ST3^{+/-} (lane 4), but not in ST3^{-/-} (lane 5) involuting uterus. Gel A expression was detected in the three types of mice. The 36B4 probe (Masiakowski et al., 1982) was used as internal control. Autoradiography was for 16 h.

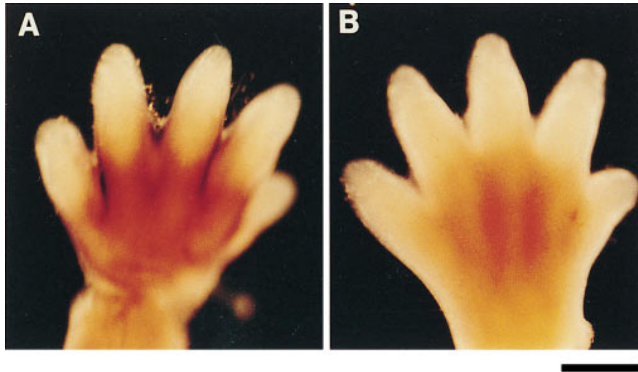

Figure 3. Whole mount RNA in situ hybridization of limb buds of $ST3^{+/+}$ and $ST3^{-/-}$ 14.5 d post-coitum mouse embryos. Photographs of whole mount in situ hybridization of $ST3^{+/+}$ (A) and $ST3^{-/-}$ (B) limb buds. $ST3$ mRNA was observed in the interdigital parts of the limb of $ST3^{+/+}$ (A) but not in that of $ST3^{-/-}$ (B) mice. No morphological differences were observed between limb buds from $ST3^{+/+}$ and $ST3^{-/-}$ mice. Bar, 500 μ m.

was intragastrically administered to 14 and 16 $ST3^{+/+}$ and $ST3^{-/-}$ mice, respectively. DMBA is a procarcinogen, which, after activation in carcinogen, reacts with DNA to form adducts leading to somatic DNA mutations and subsequent activation of protooncogenes (Sukumar, 1990). At 35 wk of age, 64% (9/14) and 87% (14/16) of $ST3^{+/+}$ and $ST3^{-/-}$ mice were alive, respectively. These mice were killed and histological examination of their liver, lung, uterus, mammary gland, and ovary was performed. Whereas all $ST3^{+/+}$ mice exhibited benign or malignant tumors, 21% of $ST3^{-/-}$ mice were devoid of any tumors (Table I). 89% (8/9) of $ST3^{+/+}$ mice and 43% (6/14) of $ST3^{-/-}$ mice had developed carcinomas of either the mammary gland or ovary (Table I), two organs known to be preferential targets for DMBA-induced tumors (Tagughi et al., 1988; Ip, 1996). In addition to this lower tumor incidence, the tumor size was clearly smaller for carcinomas found in $ST3^{-/-}$ compared with $ST3^{+/+}$ mice (mean: 38 ± 49 versus 230 ± 276 mm³; median: 16 versus 140 mm³; Table I). No obvious histological differences were observed between carcinomas occurring in $ST3^{+/+}$ or $ST3^{-/-}$ mice.

Effect of $ST3^{+/+}$ and $ST3^{-/-}$ Fibroblasts on MCF7 Tumorigenicity in Nude Mice

In human carcinomas, $ST3$ is not expressed by the cancer cells themselves, but by nonmalignant fibroblastic cells

Table I. DMBA-induced Carcinomas in $ST3^{+/+}$ and $ST3^{-/-}$ Mice

Strains	DMBA-induced mouse carcinomas*			
	No tumor	Benign tumors	Carcinomas	Size [‡]
$ST3^{+/+}$	0/9 (0%)	1/9 (11%)	8/9 (89%)	230 ± 276
$ST3^{-/-}$	3/14 (21%)	5/14 (36%)	6/14 (43%)	38 ± 49

* Animals were killed at 35 weeks of age.

[‡] Mean of carcinoma volumes in mm³; the median size of $ST3^{+/+}$ and $ST3^{-/-}$ carcinomas were 140 (range 16–729) and 16 (range 8–125), respectively. Benign tumors, ovarian hyperplasia and mammary cysts; carcinomas, ovarian and mammary gland carcinomas.

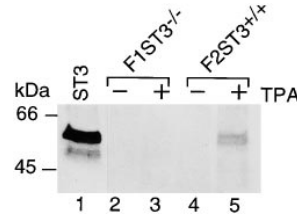

Figure 4. Western blot analysis of conditioned media (48 h) from $F2ST3^{+/+}$ and $F1ST3^{-/-}$ 15 d post-coitum embryonic fibroblasts. $F2ST3^{+/+}$ and $F1ST3^{-/-}$ embryonic fibroblasts (C57BL/6J/129/Svj) were grown in serum-free medium and in the presence or absence of TPA (10 ng/ml), as indicated. 100-fold concentrated (80% ammonium sulfate) culture media (10 μ g of total proteins) conditioned by $F1ST3^{-/-}$ (lanes 2 and 3) or $F2ST3^{+/+}$ (lanes 4 and 5) embryonic fibroblasts were loaded in each lane. Purified mature mouse $ST3$ was used as control (lane 1). Protein species were revealed using monoclonal antibody 5ST-4C10 against the $ST3$ catalytic domain (Santavicca et al., 1995) followed by enhanced chemiluminescence detection (ECL kit; Dupont-NEN, Boston, MA). The positions of 66- and 45-kD molecular mass markers are indicated.

found in their immediate vicinity (Basset et al., 1990; Rouyer et al., 1994). Thus, we designed a mouse model taking this into account in order to test the impact of the fibroblastic $ST3$ deficiency in carcinomas. $ST3^{+/+}$ and $ST3^{-/-}$ fibroblasts were derived from mouse embryos (see Materials and Methods). As expected, after treatment with 12-*O*-tetradecanoylphorbol 13-acetate (TPA), a known inducer of $ST3$ expression (Basset et al., 1990), $ST3$ was only detected in $ST3^{+/+}$ fibroblasts and corresponding conditioned media, respectively (Fig. 4). $ST3^{+/+}$ and $ST3^{-/-}$ fibroblasts showed similar in vitro proliferation rate (data not shown). Nude mice were subcutaneously injected with 2×10^5 MCF7 human breast cancer cells, which do not express $ST3$, either alone or together with 8×10^5 $ST3^{+/+}$ or $ST3^{-/-}$ fibroblasts. In three experiments performed independently, whereas MCF7 cells injected alone or in the presence of $ST3^{-/-}$ fibroblasts exhibited similar tumorigenicity, tumors developed more rapidly when MCF7 cells were coinjected with $ST3^{+/+}$ fibroblasts. The results of one of these experiments are presented in Fig. 5. Whereas 50% of injection sites presented tumors of at least 80 mm³ 15 d after coinjection with $F2ST3^{+/+}$ or $F9ST3^{+/+}$ fibroblasts, the same percentage of tumors was only reached 30 d after coinjection with $F1ST3^{-/-}$ or $F6ST3^{-/-}$ fibroblasts (Fig. 5 A). Furthermore, 100% of injection sites presented tumors between 21–30 d in the presence of $ST3^{+/+}$ fibroblasts, whereas 40 d were necessary with $ST3^{-/-}$ fibroblasts (Fig. 5 A). Consistently, kinetic analyses showed that at any time after cell injection, tumor volumes were significantly higher (at day 18, $P < 0.002$ and at day 30, $P < 0.008$) when MCF7 cells were coinjected with $ST3^{+/+}$ rather than $ST3^{-/-}$ fibroblasts or in the absence of fibroblasts (Fig. 5 B). Results were similar in C57BL/6J/129/Svj or 129/Svj genetic backgrounds (Fig. 5 A). Histological analysis showed no obvious difference between the tumors obtained after coinjection with $ST3^{+/+}$ or $ST3^{-/-}$ fibroblasts (data not shown).

ECM Participation to $ST3$ Paracrine Function

In physiological and pathological conditions, $ST3$ expression is always observed during processes including remodeling of the ECM and most particularly of the basement membrane, suggesting that $ST3$ function could be medi-

Embryonic fibroblasts	Tumor latency (days after cell injection)		
	50% tumors	100% tumors	
C57BL/6J/129/Svj	F2ST3 ^{+/+}	15	30
	F9ST3 ^{+/+}	15	21
	F1ST3 ^{-/-}	30	40
	F6ST3 ^{-/-}	30	40
129/Svj	F55ST3 ^{+/+}	<8	8
	F56ST3 ^{+/+}	<8	8
	F34ST3 ^{-/-}	21	30
	F44ST3 ^{-/-}	21	30

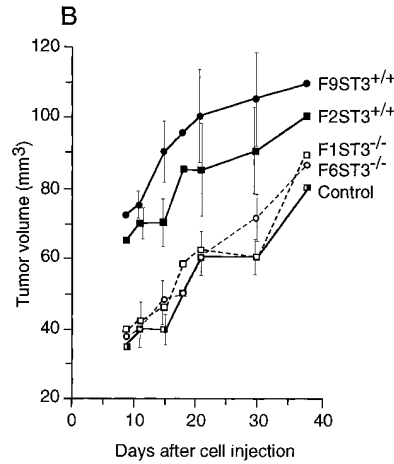

Figure 5. Analysis of the effect of ST3^{+/+} and ST3^{-/-} embryonic fibroblasts on MCF7 human breast cancer cell tumorigenicity in nude mice. (A) Tumor latency: number of days after cell injection necessary to obtain tumors (volume >80 mm³) at 50 and 100% injection sites. Each fibroblast culture (8 × 10⁵ cells) was subcutaneously coinjected with MCF7 cells (2 × 10⁵ cells) into four nude mice (BALB/c nu/nu). The fibroblast genetic background and ST3 status were as indicated. The results presented are representative of one out of 3 independent experiments. (B) Kinetics of tumor volumes measured from 10 to 40 d after injection of MCF7 cells alone (control) or in the presence of F2ST3^{+/+}, F9ST3^{+/+}, F1ST3^{-/-}, or F6ST3^{-/-} fibroblasts. Each point represents the mean of four individual values (error bars).

ated through ECM component(s) and/or associated growth factor(s) (Rio et al., 1996). To test this hypothesis, we performed MCF7 tumorigenic assays similar to that described above. However, in this experiment, matrigel, which is a solubilized basement membrane preparation (Taub et al., 1990), was either depleted or undepleted in its associated growth factors. One of three independent experiments is presented in Fig. 6. 10 d after coinjection of MCF7 cells with F2ST3^{+/+} fibroblasts, 40% of injection sites presented tumors in the presence of undepleted matrigel, whereas no tumors were observed in presence of depleted matrigel. After 30 d, whereas 100% of injection sites presented tumors in the presence of growth factors, only 20% developed tumors in growth factor-depleted condition. MCF7 cells injected alone or together with F1ST3^{-/-} fibroblasts exhibited low tumorigenicity, whatever the status of the matrigel.

Discussion

ST3 was first identified (Basset et al., 1990) and characterized in human carcinomas where its expression was correlated with tumor stage (Rouyer et al., 1994). Its expression can be used to predict the clinical outcome of patients (Engel et al., 1994; Chenard et al., 1996), thereby suggesting that ST3 plays a role in the biology and growth of carcinomas. Since *in vitro* experiments did not permit us to adequately investigate ST3 function during malignant processes, we have developed transgenic mice deficient in the ST3 gene and compared tumorigenesis in ST3^{+/+} and ST3^{-/-} mice.

ST3 Is Dispensable in Physiological Processes

ST3^{-/-} mice are fertile. Whatever their age, no obvious modifications in appearance and behavior were observed in the ST3^{-/-} C57BL/6J, BALB/c, or 129/Svj mice. Using histological analysis, tissues and organs usually known to express ST3 during embryonic development (Lefebvre et al., 1995) or adult life (Lefebvre et al., 1992) could not be distinguished from their counterparts in ST3^{+/+} mice. In addition, although ST3 has been shown to be expressed in wound healing (Wolf et al., 1992; Okada et al., 1997), tis-

sue repair subsequent to experimental skin or bone lesions performed in ST3^{-/-} mice was not disrupted. These results show that ST3 is dispensable for normal organogenesis and tissue homeostasis, suggesting that another protein(s) is able to substitute for ST3 in the ST3^{-/-} mice. A similar absence of phenotype was observed in mice deficient for two other MMPs, namely matrilysin (Wilson et al., 1997) and gelatinase A (Itoh et al., 1997).

ST3 Favors Chemically Induced Carcinomas

DMBA-induced carcinogenesis is closely related to tumor development in humans, since it corresponds to a multi-step process requiring a relatively long period from the initial genetic alterations of epithelial cells to macroscopic

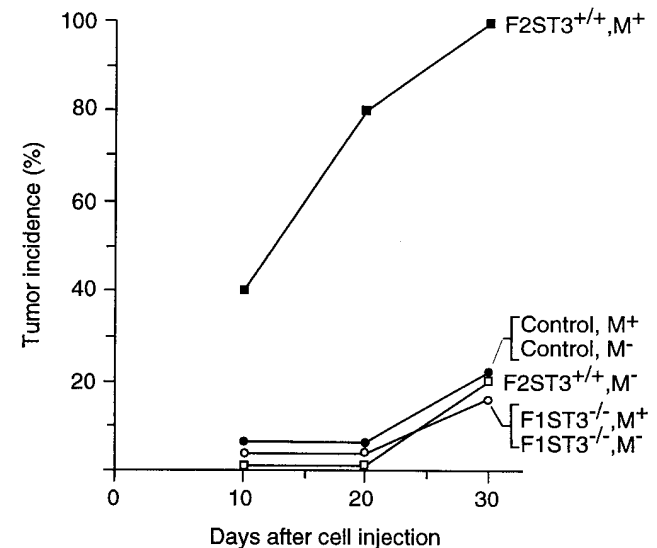

Figure 6. Analysis of the effect of the ECM-associated growth factors on the capacity of ST3^{+/+} fibroblasts to promote MCF7 cell tumorigenicity. Experimental conditions are as described in the Fig. 5 legend. Tumor incidence after subcutaneous injection of MCF7 cells either alone (Control), or together with F2ST3^{+/+} or F1ST3^{-/-} fibroblasts, in presence of growth factors depleted (M⁻) or undepleted (M⁺) matrigel.

cally detectable tumors (Sukumar, 1990). Five months after DMBA treatment of ST3^{+/+} and ST3^{-/-} mice, we observed a lower death rate and a reduced number and size of induced carcinomas in ST3^{-/-} mice. Thus, since we can assume that capacity of DMBA to transform epithelial cells is identical in both ST3^{+/+} and ST3^{-/-} mice, these results constitute the first evidence that ST3 can lead to an increased capacity of transformed epithelial cells to give rise to carcinomas. These results are consistent with the proposed role of ST3 as a promoter of tumor development and/or progression (Noël et al., 1996). In addition, these results indicate that, contrary to observations made in normal tissues, the lack of ST3 is not compensated in malignant processes. Since malignancy can be regarded as a disorganized reactivation of developmental mechanisms (Cross and Dexter, 1991), it is reasonable to speculate that a molecule that is coexpressed and able to substitute for ST3 exists in normal conditions, whereas it is not reinduced concomitantly to ST3 loss during malignancy. Similar results were recently reported for matrilysin, another MMP preferentially expressed by malignant epithelial cells. Although matrilysin deficient mice were apparently normal, the absence of matrilysin was found to reduce tumor multiplicity in multiple intestinal neoplasia animals, which carry a germline mutation in the APC (adenomatous polyposis coli) gene (Wilson et al., 1997).

ST3 Contributes in a Paracrine Manner to Epithelial Cell Malignancy

Carcinomas are composed of malignant epithelial cells and stroma, mainly composed of inert bio-matrix and non-malignant fibroblastic, endothelial, and inflammatory cells. In both primary and secondary tumors, survival and implantation of malignant cells in the connective host environment depends upon stromal-epithelial interactions (Cornil et al., 1991; Cunha, 1994; Dimanche-Boitrel et al., 1994; Grégoire and Lieubeau, 1995). In human carcinomas, ST3 is specifically expressed by fibroblastic cells located close to malignant cells, suggesting the existence of some kind of cross-talk between the two cell types and a paracrine function for ST3 (Basset et al., 1997b). In support of this hypothesis, the coinjection of ST3^{-/-} fibroblasts did not modify the tumorigenic potential of MCF7 cells, whereas ST3^{+/+} fibroblasts led to an increased tumor incidence and size ($P < 0.008$), and a reduced tumor latency. Therefore, ST3 represents a stroma-derived factor that favors, in a paracrine manner, homing of malignant epithelial cells. Moreover, since, in this model, coinjected fibroblasts are progressively substituted with connective cells from the host (Noël et al., 1993), we conclude that this effect is essential during the early steps of tumorigenesis. By analogy, in normal tissues, ST3 may carry out a paracrine function and favor epithelial cell survival during organogenesis and tissue homeostasis, since it is expressed by cells of mesenchymal origin which are located close to "stressed" epithelial cells during tissue remodeling processes (Basset et al., 1990; Lefebvre et al., 1992, 1995).

The Paracrine ST3 Function Requires ECM-associated Growth Factor(s)

From its pattern of expression, it has been proposed that

ST3 could interact with the ECM, and most particularly with the basement membrane (Rio et al., 1996). ECM is composed of high molecular mass connective molecules and associated growth factors. We took advantage of the fact that the MCF7 cell tumorigenic model, used in the presence of fibroblasts and reconstituted basement membrane gel (matrigel; Taub et al., 1990), faithfully recapitulated conditions seen in malignant processes, to study the role of ECM in ST3 function. The capacity of ST3^{+/+} fibroblasts to promote MCF7 tumorigenicity in nude mice was lost when the matrigel was depleted in growth factors, indicating that ST3 action is dependent on ECM-associated growth factor(s) but not on the ECM proteins themselves. In this context, ST3 could release and/or activate growth factors that are stored in the ECM in a latent form (Ruoslahti and Yamaguchi, 1991).

The concept that stromal MMPs may favor tumorigenesis is now well accepted (MacDougall and Matrisian, 1995; Stetler-Stevenson et al., 1996). Our findings represent *in vivo* evidence that one such MMP is actually a key player during malignancy. ST3 is a secreted, connective tissue-derived factor favoring the homing of malignant cells in host tissues in an indirect paracrine manner through recruitment of growth factor(s). Consistent with this hypothesis, high levels of ST3 expression in intratumoral fibroblasts were found to be associated with poor clinical outcome in human carcinomas (Engel et al., 1994; Chénard et al., 1996). It is currently thought that future therapeutic approaches to cancer should not only be directed against malignant cells, but also against stromal cells (Cornil et al., 1991; Cunha, 1994; Dimanche-Boitrel et al., 1994; Grégoire and Lieubeau, 1995). In contrast with malignant cells, stromal cells are genetically stable, homogenous, and have a low mutation rate. Therefore therapy directed against an intratumoral stromal cell should induce little or no acquired drug resistance (Boehm et al., 1997; Kerbel, 1997). In addition, such cytostatic therapy, which prevents the growth both of primary tumor and of metastatic foci, could be used in combination with conventional cytotoxic treatments (Stetler-Stevenson et al., 1996). In this context, ST3 represents an attractive target for specific MMP inhibitor(s) (Hodgson, 1995; Beckett, 1996) in the treatment of human carcinomas.

We thank P. Simpson for critical reading of the manuscript and J.M. Garnier, S. Vicaire, and R. Matyas for technical assistance.

This work was supported by funds from the Institut National de la Santé et de la Recherche Médicale, the Centre National de la Recherche Scientifique, the Hôpital Universitaire de Strasbourg, the Bristol-Myers Squibb Pharmaceutical Research Institute, the Association pour la Recherche sur le Cancer, the Ligue Nationale Française contre le Cancer, the Comité du Haut-Rhin, the Fondation de France, the Programme Hospitalier de Recherche Clinique 1995, the BIOMED 2 (contract BMH4CT96-0017) and BIOTECH 2 (contract ERBBIO4CT96-0464) Programmes, the Fond National de la Recherche Scientifique (FNRS; 3.4573.95, Belgium), the Fonds National de la Recherche Scientifique Télévie (7.45.80.96, Belgium), and a grant to P. Chambon from the Fondation Jeantet.

Received for publication 10 November 1997 and in revised form 16 January 1998.

References

Anglard, P., T. Melot, E. Guérin, G. Thomas, and P. Basset. 1995. Structure and promoter characterization of the human stromelysin-3 gene. *J. Biol. Chem.*

- 270:20337–20344.
- Basset, P., J.P. Bellocq, C. Wolf, I. Stoll, P. Hutin, J.M. Limacher, O.L. Podhajcer, M.P. Chenard, M.C. Rio, and P. Chambon. 1990. A novel metalloproteinase gene specifically expressed in stromal cells of breast carcinomas. *Nature*. 348:699–704.
- Basset, P., J.P. Bellocq, O. Lefebvre, A. Noël, M.P. Chenard, C. Wolf, P. Anglard, and M.C. Rio. 1997a. Stromelysin-3: a paradigm for stroma-derived factors implicated in carcinoma progression. *Crit. Rev. Oncol.-Hematol.* 26:43–53.
- Basset, P., A. Okada, M.P. Chenard, R. Kannan, I. Stoll, P. Anglard, J.P. Bellocq, and M.C. Rio. 1997b. Matrix metalloproteinases as stromal effectors of human carcinoma progression: therapeutic implications. *Matrix Biol.* 15: 534–541.
- Beckett, R.P. 1996. Recent advances in the field of matrix metalloproteinase inhibitors. *Exp. Opin. Ther. Patents.* 6:1305–1315.
- Birkedal-Hansen, H. 1995. Proteolytic remodeling of extracellular matrix. *Curr. Opin. Cell Biol.* 7:728–735.
- Boehm, T., J. Folkman, T. Browder, and M.S. O'Reilly. 1997. Antiangiogenic therapy of experimental cancer does not induce acquired drug resistance. *Nature*. 390:404–407.
- Chenard, M.P., L. O'Siornain, S. Shering, N. Rouyer, Y. Lutz, C. Wolf, P. Basset, J.P. Bellocq, and M.J. Duffy. 1996. High levels of stromelysin-3 correlate with poor prognosis in patients with breast carcinoma. *Int. J. Cancer* 69:448–451.
- Chomczynski, P., and N. Sacchi. 1987. Single-step method of RNA isolation by acid guanidinium thiocyanate-phenol-chloroform extraction. *Anal. Biochem.* 162:156–159.
- Cornil, I., D. Theodorescu, S. Man, M. Herlyn, J. Jambrosic, and R.S. Kerbel. 1991. Fibroblast cell interactions with human melanoma cells affect tumor cell growth as a function of tumor progression. *Proc. Natl. Acad. Sci. USA.* 88:6028–6032.
- Coussens, L.M., and Z. Werb. 1996. Matrix metalloproteinases and the development of cancer. *Chem. Biol. (Lond.)*. 3:895–904.
- Cross, M., and T.M. Dexter. 1991. Growth factors in development, transformation, and tumorigenesis. *Cell.* 64:271–280.
- Cunha, G.R. 1994. Role of mesenchymal-epithelial interactions in normal and abnormal development of the mammary gland and prostate. *Cancer.* 74(Suppl.):1030–1044.
- Dimanche-Boitrel, M.T., L. Vakaet, P. Pujuguet, B. Chauffert, M.S. Martin, A. Hamman, F. Van Roy, M. Mareel, and F. Martin. 1994. In vivo and in vitro invasiveness of a rat colon-cancer cell line maintaining E-cadherin expression: an enhancing role of tumor-associated myofibroblasts. *Int. J. Cancer.* 56:512–521.
- Engel, G., K. Heselmeyer, G. Auer, M. Backdahl, E. Eriksson, and S. Linder. 1994. Correlation between stromelysin-3 mRNA level and outcome of human breast cancer. *Int. J. Cancer.* 58:830–835.
- Gossler, A., T. Doetschman, R. Korn, E. Serfling, and R. Kemler. 1986. Transgenesis by means of blastocyst-derived embryonic stem cell lines. *Proc. Natl. Acad. Sci. USA.* 83:9065–9069.
- Grégoire, M., and B. Lieubeau. 1995. The role of fibroblasts in tumor behavior. *Cancer Metast. Rev.* 14:339–350.
- Hodgson, J. 1995. Remodeling MMPs. *Biotechnology.* 13:554–557.
- Ip, C. 1996. Mammary tumorigenesis and chemoprevention studies in carcinogen-treated rats. *J. Mam. Gland Biol. Neoplasia.* 1:37–47.
- Itoh, T., T. Ikeda, H. Gomi, S. Nakao, T. Susuki, and S. Itohara. 1997. Unaltered secretion of β -amyloid precursor protein in gelatinase A (matrix metalloproteinase 2)-deficient mice. *J. Biol. Chem.* 272:22389–22392.
- Kerbel, R.S. 1997. A cancer therapy resistant to resistance. *Nature*. 390:335–336.
- Lefebvre, O., C. Wolf, J.M. Limacher, P. Hutin, C. Wendling, M. LeMeur, P. Basset, and M.C. Rio. 1992. The breast cancer-associated stromelysin-3 gene is expressed during mouse mammary gland apoptosis. *J. Cell Biol.* 119:997–1002.
- Lefebvre, O., C. Régnier, M.C. Chenard, C. Wendling, P. Chambon, P. Basset, and M.C. Rio. 1995. Developmental expression of mouse stromelysin-3 mRNA. *Development.* 121:947–955.
- Loo, D., C. Rawson, T. Ernst, S. Shirahata, and D. Barnes. 1990. Primary and multipassage culture of mouse embryo cells in serum-containing and serum-free media. In *Cell Growth and Division*. R. Baserga, editor. IRL Press, Oxford, UK. 17–35.
- Lufkin, T., A. Dierich, M. LeMeur, M. Mark, and P. Chambon. 1991. Disruption of the Hox-1.6 homeobox gene results in defects in a region corresponding to its rostral domain of expression. *Cell.* 65:1105–1119.
- MacDougall, J.R., and L.M. Matrisian. 1995. Contributions of tumor and stromal matrix metalloproteinases to tumor progression, invasion and metastasis. *Cancer Metast. Rev.* 14:351–362.
- Maquoi, E., M. Polette, B. Nawrocki, P. Bischof, A. Noël, A. Pintiaux, M. Santavicca, J.P. Schaaps, P. Birembaut, and J.M. Foidart. 1997. Expression of stromelysin-3 in the human placenta and placenta bed. *Placenta.* 18:277–285.
- Masiakowski, P., R. Breathnach, J. Block, F. Gannon, A. Krust, and P. Chambon. 1982. Cloning of cDNA sequences of hormone-regulated genes from the MCF7 human breast cancer cell line. *Nucleic Acids Res.* 10:7895–7903.
- Muller, D., C. Wolf, J. Abecassis, R. Millon, A. Engelmann, G. Bronner, N. Rouyer, M.C. Rio, M. Eber, G. Methlin et al. 1993. Increased stromelysin-3 gene expression is associated with increased local invasiveness in head and neck squamous carcinomas. *Cancer Res.* 53:165–169.
- Noël, A., M.C. De Pauw-Gillet, G. Purnell, B. Nusgens, C.M. Lapiere, and J.M. Foidart. 1993. Enhancement tumorigenicity of human breast adenocarcinoma cells in nude mice by matrigel and fibroblasts. *Br. J. Cancer.* 68:909–915.
- Noël, A., M. Santavicca, I. Stoll, C. L'Hoir, A. Staub, G. Murphy, M.C. Rio, and P. Basset. 1995. Identification of structural determinants controlling human and mouse stromelysin-3 proteolytic activities. *J. Biol. Chem.* 270: 22866–22872.
- Noël, A., O. Lefebvre, E. Maquoi, L. Vanhoorde, M.P. Chenard, M. Mareel, J.M. Foidart, P. Basset, and M.C. Rio. 1996. Stromelysin-3 expression promotes tumor take in nude mice. *J. Clin. Invest.* 97:1924–1930.
- Okada, A., S. Saez, Y. Misumi, and P. Basset. 1997. Rat stromelysin-3: cDNA cloning from healing skin wound, activation by furin and expression in rat tissues. *Gene.* 185:187–193.
- Patterson, D., W. Pär Hayes, and Y.B. Shi. 1995. Transcriptional activation of the matrix metalloproteinase gene stromelysin-3 coincides with thyroid hormone-induced cell death during frog metamorphosis. *Dev. Biol.* 167:252–262.
- Pei, D., G. Majmudar, and S.J. Weiss. 1994. Hydrolytic inactivation of a breast carcinoma cell-derived serpin by human stromelysin-3. *J. Biol. Chem.* 269: 25849–25855.
- Pei, D., and S.J. Weiss. 1995. Furin-dependent intracellular activation of the human stromelysin-3 zymogen. *Nature.* 375:244–247.
- Porte, H., E. Chastre, S. Prevot, B. Nordlinger, S. Empereur, P. Basset, P. Chambon, and C. Gespach. 1995. Neoplastic progression of human colorectal cancer is associated with overexpression of the stromelysin-3 and BM-40/SPARC genes. *Int. J. Cancer.* 64:70–75.
- Rio, M.C., O. Lefebvre, M. Santavicca, A. Noël, M.P. Chenard, P. Anglard, J.A. Byrne, A. Okada, C.H. Régnier, R. Masson et al. 1996. Stromelysin-3 in the biology of the normal and neoplastic mammary gland. *J. Mam. Gland Biol. Neoplasia.* 1:231–240.
- Rodgers, W.H., L.M. Matrisian, L.C. Giudice, B. Dsupin, P. Cannon, C. Sviteck, F. Gorstein, and K.G. Osteen. 1994. Patterns of matrix metalloproteinase expression in cycling endometrium imply differential functions and regulation by steroid hormones. *J. Clin. Invest.* 94:946–953.
- Rouyer, N., C. Wolf, M.P. Chenard, M.C. Rio, P. Chambon, J.P. Bellocq, and P. Basset. 1994. Stromelysin-3 gene expression in human cancer: an overview. *Invasion Metastasis.* 14:269–275.
- Ruoslahti, E., and Y. Yamaguchi. 1991. Proteoglycans as modulators of growth factor activities. *Cell.* 289:867–869.
- Santavicca, M., A. Noël, M.P. Chenard, Y. Lutz, I. Stoll, J.P. Segain, N. Rouyer, M.C. Rio, C. Wolf, J.P. Bellocq, and P. Basset. 1995. Characterization of monoclonal antibodies against stromelysin-3 and their use to evaluate stromelysin-3 levels in breast carcinoma by semi-quantitative immunohistochemistry. *Int. J. Cancer.* 64:336–341.
- Stetler-Stevenson, W.G., R. Hewitt, and M. Corcoran. 1996. Matrix metalloproteinases and tumor invasion: from correlation and causality to the clinic. *Semin. Cancer Biol.* 7:147–154.
- Sukumar, S. 1990. An experimental analysis of cancer: role of ras oncogene in multistep carcinogenesis. *Cancer Cells.* 2:199–204.
- Tagughi, O., S.D. Michael, and Y. Nishizuka. 1988. Rapid induction of ovarian granulosa cell tumors by 7,12-dimethylbenz(a)anthracene in neonatally estrogenized mice. *Cancer Res.* 48:425–429.
- Taub, M., Y. Wang, T.M. Szczesny, and H.K. Kleinman. 1990. Epidermal growth factor or transforming growth factor a is required for kidney tubulogenesis in matrigel cultures in serum-free medium. *Proc. Natl. Acad. Sci. USA.* 87:4002–4006.
- Wang, Z., and D. Brown. 1993. Thyroid hormone-induced gene expression program for amphibian tail resorption. *J. Biol. Chem.* 268:16270–16278.
- Wilson, C.L., K.J. Heppner, P.A. Labosky, B.L.M. Hogan, and L. Matrisian. 1997. Intestinal tumorigenesis is suppressed in mice lacking the metalloproteinase matrilysin. *Proc. Natl. Acad. Sci. USA.* 94:1402–1407.
- Wolf, C., M.P. Chenard, P. Durand de Grossouvre, J.P. Bellocq, P. Chambon, and P. Basset. 1992. Breast-cancer-associated stromelysin-3 gene is expressed in basal cell carcinoma and during cutaneous wound healing. *J. Invest. Dermatol.* 99:870–872.