

The evaluation of ventilation

By O. M. LIDWELL

*Air Hygiene Laboratory, Central Public Health Laboratory, Colindale,
London, N.W. 9*

(Received 19 May 1960)

INTRODUCTION

The ventilation of an enclosed space may be expressed quantitatively in a variety of ways. The simplest measure is the volume of ventilating air supplied. Often this is divided by the volume of the space and the quotient given as the ventilation rate or the number of air changes supplied in unit time, usually 1 hr. Where the ventilating air is supplied mechanically it is in principle easy to measure the rate of supply. In practice this is often difficult and may be impossible if some or all of the ventilation is due to natural air movements. Indirect methods of assessing the ventilation rate therefore become necessary. These involve the liberation into the space of some inert gas, vapour or smoke, whose concentration in the atmosphere can easily be measured, and observation of the rate at which this tracer substance disappears from the air of the room. The ventilation rate and the rate of supply of ventilating air to the room can only be deduced from these observations if the way in which the ventilating air displaces the air already in the room is known or can be assumed. The simplest relations are found when the air in the space is continually and completely mixed with the incoming ventilating air so that the concentration of tracer substance is at all times uniform throughout the space. In these circumstances the concentration of tracer substance will decline exponentially according to the relation $C_t = C_0 e^{-Rt}$, where C_t is the concentration at time t and R is a constant numerically equal to the ventilation rate as defined above. This condition is fulfilled to a sufficient degree of accuracy in a surprisingly large proportion of instances.

If the mixing in the room is only partial the process of ventilation can no longer be quantitatively described by a single parameter and the concentrations of tracer substance observed will depend on the positions in the room at which the tracer is liberated and from which the samples are taken. Since the air movements will usually consist, in part at least, of unstable eddies, these concentrations will also vary with the time at which the tracer is liberated. The simplest quantity which can then be used to describe the ventilation relationship between two points in the room, either at one time or as an averaged value over a period of time (preferably long, compared with the pseudo-periods of the eddy variations), is the integrated concentration of tracer found at one point following the liberation of unit quantity of tracer at the other. This quantity, which may conveniently be called the 'transfer index' or the 'index of exposure to contamination', has the dimensions of the reciprocal of a volume per unit time and, as mixing becomes more

adequate, its value approximates numerically to the reciprocal of the rate of supply of ventilating air.

Even when the rate of mixing in the room is sufficient to produce an exponential decline in the concentration of tracer substance from which the ventilation rate of the space may be deduced there is usually an initial period during which irregular variations in the tracer concentration are observed. The risk from contamination liberated in the space includes these initial values, and their contribution to the total exposure may be considerable if local high concentrations can reach the sampling point. The value of the transfer index includes these effects.

Instead of liberating the tracer at a given time, or over a short period, and observing the decline of the concentration of tracer substance in the air of the room, it is possible to liberate the tracer continuously at a constant rate and to observe the equilibrium concentrations reached. Where mixing is complete at all times this equilibrium concentration is inversely related to the ventilation rate. With partial mixing the ratio of the mean concentration observed at the sampling point to the rate of tracer liberation is equivalent to the *transfer index* as defined above.

These various quantities and relations are most clearly shown in mathematical form.

If V = the volume of the room;

v = the rate of supply of ventilating air;

q = the quantity of tracer liberated;

q' = the rate of liberation of tracer;

C_t = the concentration of tracer at the sampling point at time t ;

\bar{c} = the mean equilibrium concentration of tracer at the sampling point when tracer is continuously liberated;

T = the *transfer index* as defined above;

then the ventilation rate (R) = v/V ,

and
$$T = \frac{1}{q} \int_0^{\infty} C_t dt, \quad \text{or} \quad \bar{c}/q'.$$

If mixing in the room is complete at all times then

$$C_t = C_0 e^{-Rt} = (q/V) e^{-Rt},$$

and
$$T = \frac{1}{q} \int_0^{\infty} C_t dt = \frac{1}{V} \int_0^{\infty} e^{-Rt} dt = \frac{1}{VR} = \frac{1}{v},$$

or, for continuous emission of the tracer,

$$v\bar{c} = q',$$

and
$$T = \frac{\bar{c}}{q'} = \frac{1}{v} = \frac{1}{VR}.$$

The numerical value of the transfer index in any given situation is dependent only on the units of time and volume used. Its reciprocal, which approximates under conditions of complete mixing to the rate of supply of ventilating air, may be

described as the 'equivalent ventilation' between the two points. These two quantities the transfer index and its reciprocal, have the advantage of being descriptive parameters applicable to any ventilating situation no matter how complex. In many situations they also describe directly that property of the ventilating system which is of greatest interest, namely its efficiency in protecting a given position from exposure to air-carried contamination. This is the normal hygienic purpose of ventilation whether the exposure considered is to noxious vapours or to airborne bacteria. It will be observed that these quantities are more directly related to the volume of ventilating air supplied than to the ventilation rate, which involves also the room volume. It is therefore more realistic on hygienic grounds to set out ventilation specifications in the form of the volume of ventilating air to be supplied rather than as ventilation rates. A larger room may of course need a larger ventilating volume if there are more sources of contamination in it so that, if the number of these is directly related to the volume of the room, a given hygienic standard will result in a constant ventilation rate for rooms of various sizes.

EXPERIMENTAL METHODS

A variety of gases and vapours have been used as tracer substances. Each has its disadvantages. Safety, portability, economy in use, ease of manipulation, simplicity of apparatus, reliability and accuracy are all relevant considerations.

Nitrous oxide as a tracer gas

Nitrous oxide largely fulfils all the conditions for a tracer gas to be used in ventilation measurements. It can be estimated by means of its infra-red absorption and portable apparatus with a full-scale sensitivity as low as 100 parts per million is commercially available. Several hundred determinations of the *transfer index* using nitrous oxide as the tracer gas have been made in connexion with a study of the ventilation of operating theatres. The results of this investigation will be published elsewhere (Lidwell & Williams 1960).

It is useful to have a continuous record of the concentration values at the sampling point in order to obtain a general picture of the nature of the air movements involved in a particular situation and in order to estimate the ventilation rate from the rate of decline of tracer concentration when mixing is good enough for this to approximate to an exponential form. An example of such a record is given in Fig. 1. The integrated time \times concentration product required to compute the value of the *transfer index* is, however, most easily obtained by collecting a continuous sample at a constant rate over a suitable period of time into a rubber bag, or other container, and estimating the concentration of the mixed contents at the end of the period.

In a series of measurements of the *transfer index* it is convenient to collect the sample over a limited period and to estimate the integrated time concentration product by making a correction for any gas present at the start of the experiment, e.g. a residual from a previous measurement, or still present at the end of the sampling period. This correction can be made quite small and estimated with

sufficient accuracy by assuming that the residual die-away is logarithmic with a value either determined experimentally or calculated from the known volume of ventilating air. If the concentration at the start of the experiment is C_1 and the concentration at the end of the sampling period is C_2 then the correction to be

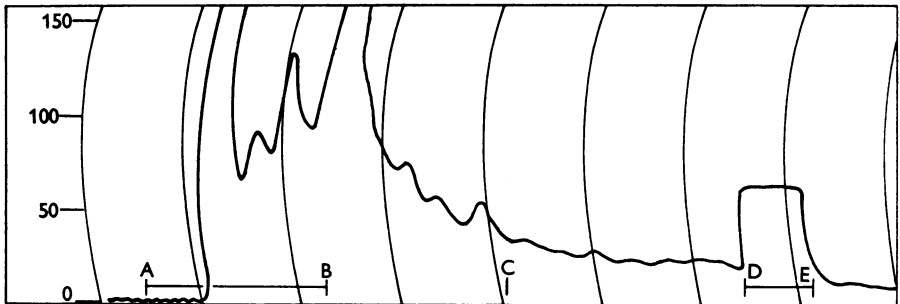

Fig. 1. Determination of the *transfer index* using nitrous oxide as a gaseous tracer. The record shows the concentration of nitrous oxide recorded just above the centre of the operating table when 9 l. (0.318 cu.ft.) of nitrous oxide were introduced into the operating theatre, 5 ft. above the floor and 5 ft. away from the sampling points, during the period of 3 min. indicated by the line *A-B* on the figure. The scale on the left-hand side of the record gives the concentrations in parts per million. Throughout the 10 min. *A-D* the sample was collected into a rubber bag at the rate of 0.5 l./min. During the period *D-E* the concentration of this sample, well mixed, was determined. Mixing in the room appears to be complete by about 3 min. after the liberation of gas ceased, marked *C*, and the concentration die-away is approximately exponential after this time.

added is $(C_2 - C_1)/R$, where R is the ventilation rate. Thus for the determination of the *transfer index* from the experiment recorded in Fig. 1 we may proceed as follows:

Concentration of tracer at start of experiment, $C_1 = 1$ part per million.

Quantity of tracer liberated, $q = 0.318$ cu.ft.

Concentration of tracer at end of sampling period, $C_2 = 19$ parts per million.

Concentration of tracer in sample collected = 62 parts per million.

Period over which sample was collected = 10 min.

Ventilation rate determined from later part of record, 3 min. or more after liberation of tracer ended, $R = 14$ air changes per hour.

(Alternatively this might have been estimated from the rate of supply of ventilating air, which was 830 cu.ft./min. into a room of 3300 cu.ft. giving $R = (830 \times 60)/3300 = 15$ air changes per hr.) Hence the integrated product of concentration and time at the sampling point is given by

$$62 \times 10 + 60(19 - 1)/14 = 697 \text{ parts per million} \times \text{min.}$$

and the *transfer index*

$$T = (697/0.318) \times 10^{-6} = 2.19 \times 10^{-3}.$$

The value of the *transfer index* which would have been expected if the air in the room had been perfectly mixed at all times is given by $T = 1/830 = 1.20 \times 10^{-3}$.

The larger value found is due to the imperfect character of the mixing process in this room. This would be expected since the air movement velocities were very

low, only about 8 ft./min. near the centre of the room. Considered in another way, the liberation of 0.318 cu.ft. of tracer gas into this room should not lead to concentrations in excess of $0.318/3300 = 96 \times 10^{-6}$, if mixing was complete. In fact concentration peaks exceeding 150 parts per million were observed.

Acetone vapour as a tracer substance

Although nitrous oxide is very satisfactory special equipment is required so that, while this would be the tracer of choice in any substantial investigation, there is still a need for a method which can be carried out using only apparatus normally available in any reasonably well-equipped laboratory. Acetone vapour can be estimated in the atmosphere by means of the change in pH which it produces on absorption into solutions of hydroxylamine hydrochloride and a method of ventilation estimation based on this is described below.

Hydroxylamine hydrochloride is dissolved in distilled water to make a solution 0.02 M (1.390 g./l.) and the pH of this solution is adjusted to 4.00 by the addition of small amounts of normal solutions of sodium hydroxide or hydrochloric acid. The solution may be kept for a few days at room temperature but slowly becomes more acid. A calibration curve for this solution is obtained by measuring the pH changes on addition of successive amounts of acetone. The calibration should be carried up to about 0.2 mg. of acetone added per c.c. of solution. This will produce a pH change of about 1.4 units. The readings in this and subsequent measurements should be made to an accuracy of about 0.02 pH units (about 1 mV.).

This solution is allowed to flow down a wick of cotton bandage wound on a piece of glass tubing (Fig. 2). The rate of flow of liquid is controlled by the capillary feed tube and the effective head produced by the constant head device. The fluid dripping off the bottom of the wick is collected. The bandage should be well boiled in distilled water before use to remove any sizes or other impurities in the cotton. The most suitable rate of flow is about 0.2 c.c./min. and the solution collected from the wick should not differ in pH from the original solution by more than about 0.05 pH units (3 mV.) so long as the air is free from acetone vapour. It may take some minutes before the pH of the dripping solution attains a constant value.

The sensitivity of the wick is determined by exposing it to known concentrations of acetone vapour, e.g. in a sealed room in which the air is kept well mixed by a fan, and estimating the acetone absorbed by the wick. It will be seen from the figures given in Table 1 that the rate of absorption of acetone vapour from the air is proportional to the vapour concentration, almost independent of the rate of air movement around it and only slightly dependent on the rate at which the solution flows down the wick.

The acetone may be evaporated into the air in any convenient way. One simple method is to form cones of filter-paper by slitting a circular piece along a radius and holding it in a conical form by means of a paper clip. The acetone in measured quantity is then run on to the cone which is placed in a Petri dish or shallow tray.

While it is possible to measure the rate of decline of the acetone concentration in the air of the room following its evaporation, the method, because of the time necessarily taken to collect a sample for measurement, is better adapted to

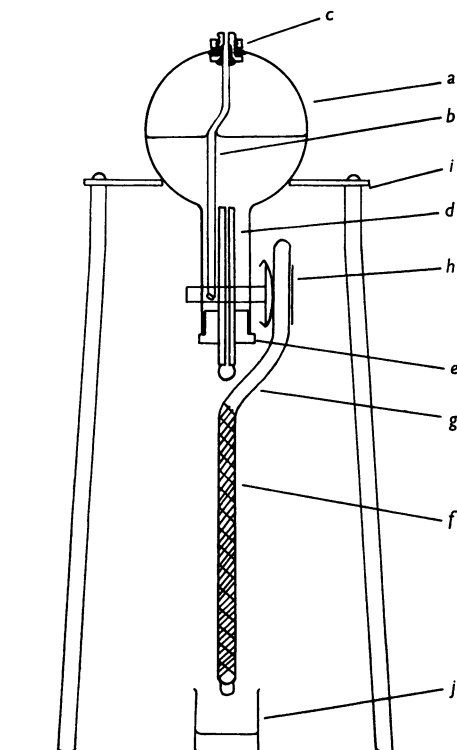

Fig. 2. Arrangements of dripping wick for acetone vapour determination. *a*, 100 c.c. round-bottom glass flask containing 0.2M hydroxylamine hydrochloride solution; *b*, air inlet tube of 3 mm. glass tubing; *c*, gland of stainless steel with rubber washer; *d*, capillary feed tube 6 cm. long, 0.5 mm. bore; *e*, rubber stopper; *f*, cotton bandage wound on; *g*, support of 5–6 mm. glass tubing; *h*, clip to support wick; *i*, stand, three-legged; *j*, 10 c.c. beaker.

Table 1. *Typical calibration data for a cotton wick*

(20–30 ft./min. was the average amount of air movement naturally present in the room. The sensitivity of the wick in undisturbed air deduced from these observations at a feed rate of 0.20 c.c./min. is 11.7 $\mu\text{g.}/\text{min.}$ at a vapour concentration of 1.0 c.c. of acetone per 1000 cu. ft. of room space.)

Rate of feed of solution (c.c./min.)	Velocity of air movement over wick (ft./min.)	Concentration of acetone vapour (c.c./1000 cu.ft.)	Acetone collected ($\mu\text{g.}/\text{min.}$)
0.20	20–30	0.5	6.0
0.20	20–30	1.0	12.1
0.20	20–30	1.5	17.1
0.20	20–30	1.0	11.4
0.20	100	1.0	11.7
0.20	215	1.0	15.0
0.09	20–20	1.0	9.5
0.125	20–30	1.0	11.0
0.184	20–20	1.0	11.4
0.251	20–30	1.0	12.4

obtaining estimates of the *transfer index* from which values of the effective ventilation rate can be deduced if required. In order to carry out a measurement of this kind one or more wicks are set up in appropriate positions in the room. After the solutions dropping from these have reached a steady pH value a suitable measured volume of acetone is allowed to evaporate at one or more chosen positions. The quantity required will depend on the efficiency of the ventilation but about 2 c.c. for every 1000 cu.ft. of room space is often suitable. The solutions dripping from the wicks are collected until their pH has returned to its original value. This is most conveniently done by collecting the solutions in portions over a series of fixed times and analysing them in succession. From the volumes of the successive portions and their pH values the total quantity of acetone collected by each wick is computed and values of the *transfer index* calculated for each.

If x μ g. of acetone are collected following the evaporation of q c.c. of acetone into the room, and previous calibration has shown that the wick collects y μ g. of acetone per minute from an atmosphere containing 1 c.c. of acetone in each 1000 cu.ft., then the value of the *transfer index* is given by

$$T = \frac{x}{qy} \times 10^{-3} \text{ (min./cu.ft.)}$$

or the equivalent ventilation between the two points is

$$\frac{qy}{x} \times 10^3 \text{ cu.ft./min.}$$

The results obtained in a typical set of measurements of this kind carried out in an unoccupied operating theatre with input ventilation designed to produce a substantial degree of air movement, approximately 50–100 ft./min. over the operating table, are shown in Table 2. There is clearly a very satisfactory degree of agreement between the two experimental methods and the numerical values derived for the mean equivalent ventilation are very close to the measured volume of input air. Measurements made with individual wicks cannot be relied upon to better than about 10%, but the apparatus is so simple that it is easy to set up as many replicates as desired. Part of the variation between the amounts of acetone recovered at the different positions in the above experiment is probably due to experimental error; the remainder reflects differences due to minor deficiencies in obtaining complete mixing.

Automatic ventilation recording

There is no doubt that convenient and reliable apparatus could be assembled for this type of measurement using nitrous oxide as the tracer substance but the necessary equipment has not been available until comparatively recently. The acetone method can also be adapted to continuous automatic operation and this was used to record the ventilation rate at hourly intervals throughout the day in a series of offices during a study of the possible effects of ventilation and other environmental conditions on the amount of minor upper respiratory infections experienced by the workers (Kingston, Lidwell & Williams, in preparation).

Table 2. *A set of measurements taken in an operating theatre*

Volume of theatre \simeq 6000 cu.ft. Volume of ventilating air measured at input grills = 1030 cu.ft./min.

20 c.c. of acetone was evaporated in two equal portions, one on each side of the operating table and the sampling times were reckoned from the time the evaporation began.

Sampling position	Sampling period	Volume of solution collected (c.c.)	pH of solution	Acetone concn. from calibration curve ($\mu\text{g./c.c.}$)	Acetone collected ($\mu\text{g.}$)
2	Preliminary 15 min.	3.1	4.04	-1*	—
	0-26 min.	5.3	3.22	41	222
	26-41 min.	3.2	3.88	5	19
3	Preliminary 15 min.	3.4	3.97	1	—
	0-27 min.	6.1	3.33	31	183
	27-42 min.	3.5	3.90	5	14

* This negative value is purely notional and arises from the fact that the pH of the solution collected during the preliminary period was slightly *greater* than the zero level of 4.00 to which the calibration curve related. Correction for the apparent initial concentration of acetone involved therefore, in this experiment, increasing the indicated value, i.e. $(41 + 1) \times 5.3 = 222$. In the experiment at sampling position 3 the correction reduces the indicated value i.e. $(31 - 1) \times 6.1 = 183$.

The total mass of acetone collected in each of the six sampling positions used, the last two were on the operating table itself, was

288, 241, 197, 186, 254 and 206 $\mu\text{g.}$ or a mean value of 229 $\mu\text{g.}$

Since 20 c.c. of acetone were evaporated and the sensitivities of the wicks were 11.7 $\mu\text{g./min.}$ for an atmosphere containing 1 c.c. of acetone in each 1000 cu. ft. the mean value of the transfer index, T is given by

$$T = \frac{229}{20 \times 11.7} \times 10^{-3} = 0.98 \times 10^{-3} \text{ (min./cu.ft.)},$$

or a mean equivalent ventilation of $1/T = 1010$ cu.ft./min. Comparable measurements done using nitrous oxide as a gaseous tracer gave a mean value for T of 0.96×10^{-3} or a mean equivalent ventilation of 1040 cu.ft./min.

To do this air from the sampling point was drawn over a wick wound directly on to a miniature glass electrode, held vertically, down which the hydroxylamine solution was fed at a constant rate from a mechanically driven syringe. A calomel electrode made contact with the lower end of the wick through a porous potassium chloride bridge. A timing device sprayed a predetermined volume of acetone into the air at regular intervals, e.g. every hour, and the changes in pH of the hydroxylamine solution as it reached the lower end of the wick were recorded through a recording pH meter. Owing to the approximately logarithmic relation between pH change and acetone concentration an exponential decline in tracer concentration leads to a linear variation of pH with time, a fact which greatly facilitates the evaluation of a series of records. As the response of this device to changes in acetone concentration in the sampled air is relatively slow, the rate of change of pH with time recorded by the instrument is not a constant multiple of the ventilation rate as given by the exponential decay constant but depends on the value of this

constant. It is necessary therefore to calibrate the equipment at a series of known ventilation rates. This can be done using a small sealed chamber, which need be of only a few cubic feet capacity. The calibration data for one instrument of this type are given in Table 3.

Table 3. *Calibration of automatic recording wick*

(The calibration was carried out with an air-flow of 1 cu.ft./min. of air drawn past the wick contained in a 1 in. diameter glass tube. The hydroxylamine hydrochloride solution (0.20M) was adjusted to pH 4.0 and fed to the wick at 0.096 c.c./min.)

Ventilation rate (air changes/hr.)	pH change recorded per air change
0	0.36
5	0.33
10	0.30
15	0.27
20	0.24

SUMMARY

The problem of describing quantitatively the effective ventilation in a room when the air within the room is imperfectly mixed is discussed. It is suggested that the protection afforded by the ventilation to any given position against airborne contamination liberated at any other position can be best expressed in terms of the integrated exposure at the first point following liberation of a tracer substance at the second. This quantity is called the *transfer index* and its reciprocal the *equivalent ventilation* approaches numerically to the rate of supply of ventilating air as the mixing of air within the room approaches completeness. Nitrous oxide is a convenient tracer gas for making such measurements.

A method is also described whereby estimates of the *transfer index* can be made employing only such apparatus as is easily available in a reasonably well-equipped laboratory. This method employs acetone vapour as a tracer substance. The concentration of this vapour in the air is measured by the pH change produced in a dilute solution of hydroxylamine hydrochloride as it flows down a cotton wick exposed to the atmosphere.

REFERENCES

- KINGSTON, D., LIDWELL, O. M. & WILLIAMS, R. E. O. (1960). (In preparation.)
 LIDWELL, O. M. & WILLIAMS, R. E. O. (1960). *J. Hyg. Camb.*, **58**. (In the Press.)