

## STUDIES ON MALARIAL PARASITES

### VII. METHODS AND TECHNIQUES FOR CULTIVATION\*

BY QUENTIN M. GEIMAN, PH.D., CHRISTIAN B. ANFINSEN, PH.D., RALPH W. MCKEE, PH.D., RICHARD A. ORMSBEE, PH.D., AND ERIC G. BALL, PH.D.

(From the Department of Comparative Pathology and Tropical Medicine, Harvard School of Public Health and Harvard Medical School, and the Department of Biological Chemistry, Harvard Medical School, Boston)

PLATES 23 AND 24

(Received for publication, July 19, 1946)

When Laveran (1) discovered living malarial parasites over 65 years ago in the blood of patients with certain fevers, a new era in the study of malaria was initiated. This discovery of malarial organisms and the subsequent experimental proof by a series of workers that they were the etiological agents of the disease failed, however, to lead to the immediate successful cultivation of the parasites. The cultural methods being developed at that time for bacteria were tried in efforts to grow these erythrocytic parasites using a variety of materials, ranging from marsh mud to human blood. Claims were made for successful cultivation but they remained unconfirmed when the work was repeated.

Sacharoff, 1890, and Rosenbach, 1890 (see Thayer and Hewetson, 2) tried the use of leeches to get development and multiplication outside the human body, but these workers merely got survival and only partial development of the parasites. The search for methods of cultivation continued after Ross and the Italian workers at the turn of the century discovered the mosquito cycle and transmission of the malarial parasite. Little success was obtained, however, until Bass and Johns (3) reported cultivation of two species of malarial parasites. The original method consisted of the addition of glucose to 2 cc. of defibrinated blood, incubation of the mixture, and examination at intervals for the parasites which were supposed to grow on the top layer of the sedimented red blood cells. This method was widely used and modified in some cases to study the development of the plasmodia and even to diagnose malaria in India. Claims were made for the development of three generations of human plasmodia by this method (4, 5), but quantitative figures were not given and it is extremely difficult to evaluate these claims.

During the subsequent years, a variety of methods was tried with avian malarial parasites, but little success was obtained (reviewed by Trager, 6). The best results were obtained by Trager (6, 7) working with the avian parasite, *Plasmodium lophurae*. He studied the conditions affecting the survival of this parasite *in vitro* and was able to obtain survival up to 16 days at 40–41°C. The medium contained a red cell extract in balanced salt solution, glutathione, glucose, serum, embryo extract, and calcium pan-

---

\*The work described in this paper was done under a contract recommended by the Committee on Medical Research between the Office of Scientific Research and Development and the President and Fellows of Harvard College.

tothenate. Daily replacement of about half of the medium was made and fresh red cells were added every 2nd day. Small Erlenmeyer flasks were used as containers; the flasks were gently agitated and different gas phases were tried in some experiments. Coulston (8) working with *P. circumflexum* achieved results somewhat comparable to those of Trager but no details have been published. Hawking (9) in experiments with *P. gallinaceum* and pursuing the leads furnished by the work of Trager "concluded that apart from the beneficial effects of red blood cell extract and glutathione, the other agents investigated caused little definite improvement in the survival of the parasites and that no substantial multiplication of the parasites could be achieved."

The finding by Huff and Bloom (10) that the avian parasite, *Plasmodium elongatum*, was capable of living in all blood and blood-forming organs of the canary, and the discovery of the exoerythrocytic development of *P. gallinaceum* by James and Tate (11) provided the stimulus for extensive research on these stages and their relation to development of sporozoites (injected by the mosquito) into the erythrocytic forms. More recently, tissue culture of these stages has been attempted because of the possible relation of this type of development to the phenomenon of relapse and also because knowledge about the biology of the tissue stages may aid in finding drugs that could be used for true prophylaxis. Huff and Bloom (10) reported some brief experiments with tissue cultures of bone marrow in an attempt to observe the life cycle in living cells. Hegner and Wolfson (12) failed to reach a conclusion in their attempt to separate the exoerythrocytic forms from erythrocytic stages of *P. cathemerium* by tissue cultures in roller tubes, but birds inoculated with material from 8 day tissue cultures became infected. Gavrilov, Bobkoff, and Laurencin (13) were able to cultivate bone marrow infected with *P. gallinaceum* and infect chickens at the end of 10 days. Rodhain, Gavrilov, and Cowez (14) cultured embryonic tissues of the chick with sporozoites of *P. gallinaceum* but they failed to get development and the results of Paraense, Meyer, and Menezes (15) (cited by Beltran, 16) were also negative. However, the first striking success with tissue culture of malarial parasites was reported by Hawking (17, 9). The technique involved the infection of 8 to 10 day old chicks by the intravenous injection of sporozoites of *P. gallinaceum*. Eight to 9 days later when exoerythrocytic stages were numerous, spleen, liver, bone marrow, or brain were implanted in roller tubes or Carrel flasks. Growth, multiplication, and survival were obtained up to the 89th day of culture. These tissue stages were infective for chicks after varying intervals of cultivation. Subcultures were obtained but they were considered difficult and uncertain. In view of the recent description of the development of *P. gallinaceum* from sporozoites to erythrocytic trophozoites by Huff and Coulston (18), the technique of Hawking should be extremely useful for future investigations.

A brief review of the attempts at propagation of malarial parasites outside the host would not be complete without mention of studies on the infection of developing chick embryos. No positive results have been reported with primate species of plasmodia but the method of Eichorn (19) for inoculating chick embryos has been used for studies with *P. lophurae* of the chicken and other avian parasites. Wolfson (20) succeeded in infecting duck embryos with *P. cathemerium*, *P. elongatum*, and *P. lophurae*, and Stauber and van Dyke (21) using duck embryos and *P. cathemerium* obtained reproducible fatal infections with a high level of parasitemia 6 to 11 days after inoculation. These authors also used *P. lophurae* but with this organism the results were variable. Haas

(22) obtained transmission of *P. gallinaceum* by the direct bite of *Aedes aegypti* on developing chick embryos, getting demonstrable infection in the hatched chicks. Haas, Feldman, and Ewing (23) carried *P. gallinaceum* through 14 serial passages by inoculating 10 to 13 day chick embryos intravenously with parasitized blood.

A review of the efforts to cultivate malarial parasites prior to 1943 indicated the need for basic information about the parasites and their environment. Thus, our method of attack became a systematic analysis of the biochemistry of the malarial parasite and the environment in the host which supports the parasite (McKee *et al.*, 24). The data gained by such studies have formed the basis for the techniques to be discussed here. The primary purpose of these *in vitro* studies up to the present has not been to obtain survival of the parasites for indefinite periods but to perform short term experiments with the parasites multiplying *in vitro* in order to obtain some information about the metabolism, nutrition, immunology, and chemotherapy of malarial parasites.

The procedures used for the analysis of the metabolic behavior of a malarial parasite and the data obtained have been the subject of two previous papers (Ball *et al.*, 25, and McKee *et al.*, 24). The present paper describes the experimental procedures used for the production of sufficient parasites for study, the methods used for counting and evaluation of parasites, the apparatus and techniques for *in vitro* cultivation, and the results obtained in the cultivation experiments.

### *Experimental Procedures*

*Choice of Parasites.*—Since a constant and abundant source of human parasites did not exist for study, animal species of plasmodia had to be used for the initial experiments. High concentrations of parasites reaching 65 per cent  $\pm$  of the red blood corpuscles are obtainable in monkeys (*Macaca mulatta*) infected with *Plasmodium knowlesi* and in chickens and ducks infected with *P. lophurae* and *P. gallinaceum*. The presence of nuclei in avian red cells, however, introduces complicating factors for biochemical studies. *P. knowlesi* was selected because (1) the host red cell is non-nucleated, (2) the disease caused by this parasite usually terminates fatally in *M. mulatta* in 6 to 12 days, (3) the parasite has a 24 hour asexual cycle of development (a fact which simplifies and hastens experiments), (4) quantities of parasites can be produced for *in vitro* studies, and (5) the organism will produce clinical malaria in man. Also because of the latter fact it seemed that results from experiments with this simian parasite might be more readily applied and adapted for the study of human plasmodia and thus lead to an interpretation of the fundamental factors involved in the production of malaria in man.

The strain of *Plasmodium knowlesi* used throughout our experiments was sent to us on July 27, 1943, through the courtesy of Major George W. Hunter 3rd, of the Army Medical School, Washington, D. C. The strain had been sent originally to the Army Medical School on September 7, 1941, by Dr. L. T. Coggeshall, from the Laboratories of the International Health Division, The Rockefeller Foundation, New York City.

*Handling of Monkeys.*—During the past 2½ years, *P. knowlesi* has been maintained by passage through monkeys (*Macaca mulatta*) with 127 animals being used in that time. Chronic infections were established initially in two monkeys with the use of quinacrine (atabrine). To avoid the possibility of spontaneous cure in chronic infections and the loss of the

strain, chronic infections were established in two additional animals at intervals of 9 to 10 months.

In the course of our studies, 21 monkeys were inoculated directly with blood from chronic infections. The remainder received their infections by serial passage from untreated animals. Infected blood was inoculated usually into a normal animal on the same day it was obtained from the donor. On a few occasions, blood was stored at 4-8°C. for 24 hours or more before inoculation. This procedure was avoided whenever possible because animals inoculated with stored blood of a given parasite density had a longer course of the disease, a result caused perhaps by loss of viability of a certain percentage of parasites.

Monkeys for infection and studies on normal blood were kept in groups of 4 to 8 in large cages. If the animals were to be used for frequent bleeding, they were tagged and then placed singly or doubly in units of a large compound cage. Animals were kept in single cages after inoculation to facilitate catching them at periodic intervals for examination. Monkeys with chronic malaria were placed in units of the large compound cage.

After the animals were inoculated with *P. knowlesi* the course of the infection was followed daily or according to the requirements of the experiment. For routine blood and parasite counts, blood was taken after lancet puncture from the marginal ear vein. When larger quantities of blood up to 40 cc. were needed for experiments, the withdrawal was made from a superficial leg vein or from the femoral vessels in the inguinal region. If larger quantities of blood were needed, the animals were placed under nembutal anesthesia (32 mg./kilo body weight) permitting exsanguination by the withdrawal of blood directly from the heart with a syringe. Sterile technique was practiced throughout. Several animals were exsanguinated by cannulation of the femoral artery, but the time consumed and difficulties involved in maintaining sterility made the procedure impractical.

Diet is extremely important in the maintenance of healthy monkeys (26-30). Furthermore, evidence has been obtained that there is a definite relation between the course of malarial infection in monkeys on "balanced" and on deficient diets (31). Consequently, the diet in present use was devised to maintain the animals in a maximum state of nutrition and growth.

During the early stages of the project, oranges, cooked whole wheat fortified with brewer's yeast, occasional lettuce, and corn were used. This diet was later varied for practical reasons to consist of oranges and raw potatoes on alternate days, dog biscuits (Purina), carrots, and cooked wheat fortified with yeast. Difficulty with nutrition was experienced only during one period of 6 weeks when a severe market shortage of fruits and potatoes existed.

Tuberculosis was not a problem in our series of animals perhaps because of the short-term experiments and because of their good nutrition. Only two tuberculous animals were found in 127 infected monkeys and they were obtained second-hand after being used for experiments elsewhere.

*Dosage of Parasites.*—During the 1st year of our investigations, the dosage of parasites to be injected was arrived at empirically though guided by the results of Coggeshall and Kumm (32) and Coggeshall and Eaton (33). Later the animals were weighed and given a certain dosage of parasites per kilo of body weight. The concentration of parasites in infected blood employed for inoculation was determined by methods described below. The actual dosage, however, varied according to the needs and time schedule of the experiment to be performed. Nevertheless, even with standardized dosages and uniform routes of injection, the course of infection will vary from monkey to monkey. This fact is illustrated by the representative data given in Table I and also by

the work of Richardson *et al.* (cited by Aberle, 34). Certain lots of monkeys differ more than others, indicating the existence of physiological factors that are difficult to assess in an animal prior to infection. Experiments showing the relation of vitamin C to the course of infection with *P. knowlesi* are being reported elsewhere (31).

For convenience in planning and completing experiments, an attempt was made usually to limit the course of the disease to approximately 7 days. Such a course of infection (5 to 7 days) gave a sharp daily rise in parasitemia with less destruction of red blood cells than in the more prolonged course up to 12 days' duration. The short course was of advantage in yielding maximum numbers of parasites per unit volume of blood.

In order to obtain the most active parasites, it was found advisable early in our studies not to wait until the terminal stages of infection. When 50 per cent or more of the red cells are parasitized, the effects of the disease on the host are reflected by severe anemia, (1.6 to 2.76 millions red blood cells per c. mm.), increased fragility of the red blood cells (Table II), alterations in the blood plasma, and degenerative changes in the parasites. Consequently, blood samples were drawn near the time when a plot of the descending red cell count crossed the ascending parasite count (Text-fig. 1). It should be noted however that the longer course of infection (8 to 12 days), though producing a greater drop in red cell count before an appreciable rise in parasitemia, did result in a more synchronous infection.

Sterile techniques were employed throughout the passage of parasites from animal to animal and the routes used for inoculation depended upon the experimental requirements. The majority of the animals were injected intravenously, but when it was desired to prolong the course of the disease, intraperitoneal injection was employed. By this latter route the blood elements and parasites are presumably arrested temporarily in the regional lymph nodes as was shown by Drinker *et al.* (36) in the case of homologous red cells. This is in contrast to the rapid entrance of trypanosomes into the peritoneal circulation after intraperitoneal injection (37).

*Counting and Evaluation of Parasites.*—The development of critical and practical methods of parasite control was needed not only to follow the course of infection in the experimental hosts but to follow the survival, growth, and multiplication of the parasites during *in vitro* experiments. The fact that the developmental stages of *P. knowlesi* are commonly synchronous makes it possible to follow growth at intervals during the 24 hour asexual cycle (38). The survival and multiplication of parasites can also be determined by counting procedures, and this information is invaluable for the interpretation of the closely coordinated cultural and biochemical studies. Although parasite control is time consuming, this phase of the work is considered essential for the calculation of quantitative data and for the arbitrary evaluation of qualitative results. Furthermore, the blood films made from our experiments have been filed so that they are continually available for comparison and checking with succeeding experiments.

Since the making of thick and thin blood films is a universal procedure for the diagnosis of



TABLE I—*Concluded*

Monkey		Inoculum Dosage and Route	Days after inoculation											
No.	Weight		1	2	3	4	5	6	7	8	9	10	11	12
Red blood count in millions Per cent parasitized cells														
6-2	kg.	1000 × 10 <sup>4</sup> i.v.				5.54 0.8	4.82 11.0	3.93 21.0						
6-8	5.5	6 mil./kg. i.v.	6.52 +	6.81 +			6.19 1.6	5.45 8.1	4.13 9.5*					
7-2	2.9	6 mil./kg. i.p.	6.76 +	5.76 0.03	5.83 6.1									
7-5	2.3	3 mil./kg. i.p.	7.43 Neg.		7.37 Neg.	6.86 +		7.37 Neg.	6.43 +	6.83 0.5		4.50 16.2	2.28 16.0	
8-2	3.4	1½ mil./kg. i.v.	6.09 Neg.		7.21 +	6.10 0.7	5.90 9.1	5.10 47.0						
8-6	6.0	3 mil./kg. i.v.		5.66 +		4.64 7.7	2.54 38.1							
9-3	1.9	12 mil./kg. i.v.	6.77 +	6.54 0.5	4.79 1.9	4.52 24.9								
9-4	2.35	6 mil./kg. i.v.	6.59 +	5.49 0.1	5.30 1.1	4.74 18.6	2.40 75.6*							
9-5	1.95	12 mil./kg. i.v.	5.95 +	6.51 1.1		5.51 20.4								
1-01	2.75	6 mil./kg. i.p.	4.89 +	4.99 +	4.87 0.9		4.99 2.4	4.38 0.8	3.55 8.5	2.63 20.6	1.56 13.5§			

All monkeys listed were exsanguinated except No. 8-2. Dosage given in terms of number of parasitized cells injected.

- + = parasites present.
- i.v. = intravenous injection.
- i.p. = intraperitoneal injection.
- mil. = million.
- \* Black water fever.
- ‡ Other pathology.
- § Tuberculosis.

malaria, the mechanics of the technique will not be discussed here. However, we soon learned that counting of parasites on a thin film made on a microscopic slide failed to give results of sufficient accuracy. The parasitized cells are of a different density than the normal red cells. Thus they accumulate in greater numbers on the edges and at the tail of the film. Since the hematologists have the same problem in getting reliable differential counts of leucocytes, we

adopted their solution of the problem (Wintrobe, 39) by making thin films on cover glasses ( $\frac{3}{8}$  inch square).

TABLE II  
*Fragility of Erythrocytes in Normal and Parasitized (*P. knowlesi*) Blood of Monkeys (*M. mulatta*)\**

Total No. monkeys	Total No. tests	Percentage parasites	Average fragility	Range of fragility
21	36	0	0.49-0.33	0.54-0.30
14	21	1-15	0.53-0.34	0.60-0.28
10	14	16-25	0.52-0.35	0.60-0.30
10	11	25-54	0.61-0.36	0.68-0.32

\* Fragility tests were made on blood from twenty-one normal monkeys and twenty parasitized monkeys at different stages of the infection. The method of Giffin and Sanford (Beck, 35) was used except for one modification. Hypotonic sodium chloride solutions were made up separately instead of from one stock solution.

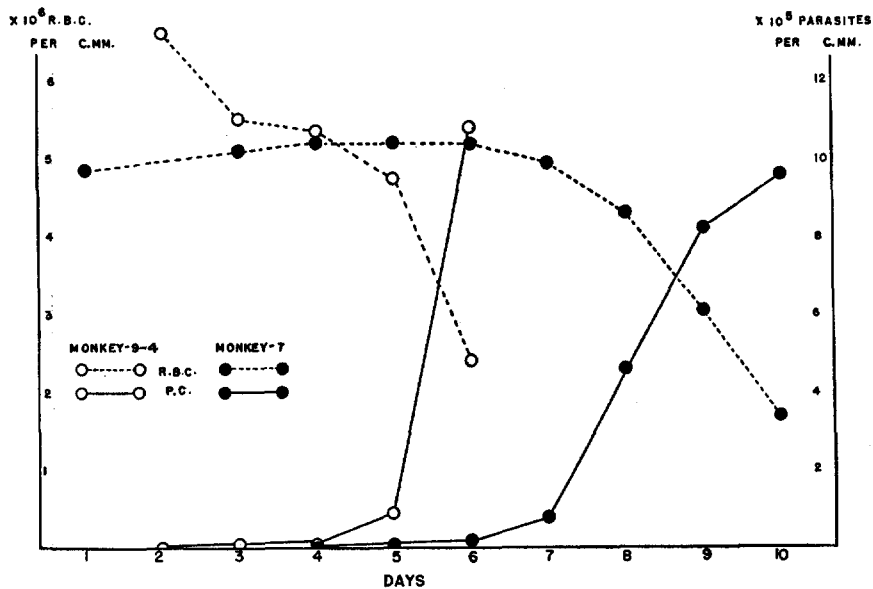

TEXT-FIG. 1. The course of malarial infection in monkeys (*Macaca mulatta*) inoculated intravenously with *Plasmodium knowlesi*. Monkey 9-4 weighing 2.35 kg., received 6 millions of parasites/kilo or 14.1 millions. Monkey 7, weighing 6.2 kilo, received 4 cc. of blood from a chronic infection containing rare parasites (too few to count).

Procedures for the staining of malarial parasites are universally known and the majority of methods involve the various types of the Romanowsky polychrome stains of which the Giemsa stain is the most widely used. Many modifications of the original technique have been suggested and newer stains, such as Field's stain, require less time for completing a



satisfactorily stained film. We adopted the technique of Wilcox and Logan (40) for the preparation of the stock Giemsa, Wright, and Wright-Giemsa staining solutions using certified American made stains (National Aniline Division, Allied Chemical & Dye Corporation). Buffered water was made by the method of Field and Le Fleming (41). (Dissolve 0.85 gm. of anhydrous disodium phosphate ( $\text{Na}_2\text{HPO}_4$ ) and 0.4 gm. of potassium acid phosphate ( $\text{KH}_2\text{PO}_4$ ) in 1000 cc. of distilled water. This solution should have a pH of 7.2-7.4. If a different pH is desired, the quantities of salts are varied according to Sorenson's buffer standards.) Since the pH of the water used for dilution is so important for uniform results, new lots were always checked and readjusted if necessary to a pH of 7.2-7.4.

The time of staining used by Wilcox and Logan (40) is satisfactory for human malaria parasites but it had to be adjusted for *Plasmodium knowlesi*. This simian parasite has very dense cytoplasm and pigment and requires only 20 minutes for adequate staining in a 2 per cent solution of Giemsa. The property of staining densely enabled us to make well stained and differentiated thin blood films with Wright's stain. In fact, Wright's stain was used entirely for daily counts in thin blood films and for our *in vitro* experiments, but duplicates were made also by the Giemsa technique for comparative reasons. Films made from *in vitro* experiments or cultures containing heparinized blood required longer staining (11 to 14 minutes). Thick films were stained with Wright-Giemsa stain using the technique of Wilcox and Logan (40), but here again duplicates were stained by the longer Giemsa method whenever the importance of an examination or experiment warranted it.

The counting procedures for malarial parasites on stained thick and thin films involved the direct observation and enumeration of parasites per total number of leucocytes or erythrocytes. Leucocyte and erythrocyte counts were made with the aid of certified diluting pipettes and the bright line counting chamber. An ocular containing a Howard disc was used to facilitate the counting process for parasites. The counting was done by carefully trained technicians who demonstrated reliability in the identification of typical and atypical parasites. Counts were made by random sampling of well stained portions of thin films where the red cells were separated and in a single layer. Thin films on cover glasses were used for counting throughout our *in vitro* studies and for *in vivo* studies when the count became 0.5 per cent or higher. Total parasite counts of less than 0.5 per cent obtained in some experiments with antimalarial drugs, have a high experimental error, but at least the evaluation is made on the same comparative basis. Thick films were used primarily for determining parasite counts during the early course of infection in monkeys and in human beings. They were not satisfactory for *in vitro* studies because of the tendency of the leucocytes to agglutinate spontaneously or to adhere to the sides of culture vessels.

Whenever it was practical or important to do so, the probable error in counting was reduced to 10 per cent by calculating the number of cells to be counted according to the formula given by Gingrich (42). The formula  $N = 45.494 \frac{I \cdot P}{P}$ , in which  $N$  equals the number of red cells,  $I$  equals the sample unit (10,000 red cells), and  $P$  equals the number of parasites per sample unit, can also be used for a probable error of 15 per cent by substituting the factor 20.2175 and for a probable error of 20 per cent by substituting the factor 11.370. Tables were calculated for daily use to indicate the required counting to be done with different samples for the various probable errors.

For experiments of a preliminary nature, samples were counted for a probable error of 15 or 20 per cent but sufficient counting was done in crucial experiments to reduce the error to 10 per cent. This procedure is considered of great importance in experiments which were set up to study the biochemistry of the parasites and to determine the nutritional requirements of the parasites. Furthermore, in crucial experiments, a given portion of the sample to be counted was done on different cover slip preparations. Very frequently, the films of the

same sample to be counted were divided between two individuals and then an average was taken of the results which could be calculated as number of parasites per cubic millimeter and also as total percentage of parasites. For the *in vitro* cultivation experiments, this figure was broken down further to give the percentage of identifiable stages of parasites, the percentage of non-identifiable stages, and the percentage that was extracellular or degenerate.

During the procedure to determine the total percentage of parasites, the differential count of the parasites observed was also recorded either by a hand tally or by the use of a Marble calculator. One hundred consecutive parasites were usually studied for such a differential, but when the total percentage was too low, the differential was calculated from the direct observation of only twenty-five parasites. For special comparative studies between control cultures and cultures containing different nutrients or antimalarial drugs, five hundred or more parasites were observed.

Another very important part of parasite control is the description of parasites at the beginning, during the course, and at the end of experiments. Since the volume of work to be done was so great and since criteria of evaluation are apt to change during a prolonged series of experiments, a method of arbitrarily evaluating or standardizing the description of parasites was necessary. To do this a blank form was devised which listed the possible categories of variation or effects on the parasite and host cell that might occur during an experiment. The condition of the parasite, *i.e.*, cytoplasm, chromatin, and pigment, was evaluated. If a sample was taken at the time of segmentation and reinvasion, the number of merozoites that were formed gave an indication as to whether the growth had been normal. Quantitative information showing rate of multiplication as well as qualitative information showing the percentage of normal parasites was recorded to assess the general behavior of the organisms and the progress of asexual development. Also recorded was the condition of the host cell and the appearance and stainability of leucocytes. No evidence was obtained to suggest that white cells were ingesting parasitized cells in quantities that affected the final results. The ingestion of debris and particularly parasite pigment by the leucocytes "cleans" the culture and the resultant engorged white cells serve as indicators for parasite growth, segmentation, and multiplication. Theoretically better multiplication can be expected *in vitro* than *in vivo* because the parasitized cells and the invading merozoites are not exposed to the phagocytic action of the entire reticulo-endothelial system.

*Concentration of P. knowlesi for in Vitro Studies.*—Since measurable quantities of cells parasitized with *P. knowlesi* were needed for basic biochemical experiments, a method of concentrating parasitized red cells was needed. The reasons for not using blood taken in the terminal stages of the disease have been given above and blood containing 15 to 25 per cent parasites taken 1 to 2 days earlier failed to give the parasite yield needed in many types of experiments. The presence of 25 per cent or more of normal red cells increased the experimental error in the biochemical studies and also increased the volume of blood containing parasites which had to be used for *in vitro* growth and multiplication.

During routine hematological procedures with parasitized blood containing balanced oxalate as an anticoagulant<sup>1</sup> (39) the separation of a distinct "feathery

<sup>1</sup> Add 1.2 gm. ammonium oxalate and 0.8 gm. potassium oxalate to 100 cc. distilled water. Measure 0.5 cc. into bottles to take 5 cc. of blood. Sterilize and allow solution to dry before using.

layer" was noted after sedimentation for 1 hour in hematocrit tubes. Upon examination, this brownish red or "feathery" layer was composed almost wholly of parasitized red cells (Fig. 1) and white cells, showing that differential sedimentation of parasitized and normal red cells had taken place.

TABLE III  
Concentration of *P. knowlesi* by Differential Sedimentation

		Sedimentation reading	Parasite % R.B.C.	Differential			Sedimentation reading	Parasite % R.B.C.	Differential			Sedimentation reading	Parasite % R.B.C.	Differential					
				Ring	Troph.	Schz. and Gam.			Ring	Troph.	Schz. and Gam.			Ring	Troph.	Schz. and Gam.			
No. experiment.....		2						3						4					
Whole blood.....			20 3.14	1	81	19		38 2.66	28	65	7		23 4.00	58	26	16			
Sed. layers	Clear	mm. 1					mm. 2					mm. 1							
	Feathery	58	106		89	11	66	105		96	4	50	100	8	39	53			
	Conc. R.B.C.	41	6	2	72	26	32	10	88	2	49	18	49	37	14				
No. experiment.....		18						26						32					
Whole blood.....			8 3.45	6	91	3		13 4.42	12	80	8		51 3.42	36	55	9			
Sed. layers	Clear	1					1					2							
	Feathery	57	68	1	95	4	37	94		85	15	20	90	14	44	42			
	Conc. R.B.C.	42	4	5	95		62	10	33	65	2	78	45	77	18	5			

These experiments were carried out in capillary tubes at room temperature. After 1 hour the tubes were broken at the levels of the different layers and films were made. The anticoagulant used was oxalate in Experiments 2, 3, 18, and 26; citrate in Experiment 4; and heparin in Experiment 32. Troph., trophozoites; schz., schizonts; gam., gametocytes; conc., concentrated; and R.B.C., red blood cells in millions.

Studies were then initiated to determine the yield of parasitized cells by differential sedimentation, the effects of different anticoagulants and defibrination on the process, and the effects of temperature.

A series of thirty-six experiments was performed and for the sake of brevity, certain typical results with differential sedimentation, depth of parasite or "feathery" layer, and differential count are presented in Table III. The sharpest demarcation between layers and the best yields are obtained when the parasitized blood contains anticoagulants, such as sodium citrate, balanced oxalate, or heparin. Heparin was the anticoagulant finally used to obtain

the heavily parasitized suspensions for experimental purposes because no demonstrable biochemical effects on the parasites could be detected and no inhibition of growth occurred when the parasites were cultivated. The parasite layer is clearly defined after 20 minutes to 1 hour at room temperatures and the depth of the layer depends upon the parasite percentage and the age of the parasites in the blood. The process is hastened by a temperature of 38°C., and retarded at a temperature of 8°C. (Text-fig. 2). However, the process proceeds sufficiently fast in the cold to make the procedure useful when it is necessary to retard the growth and still obtain heavily parasitized suspensions. The process also has the advantage of minimizing the handling of

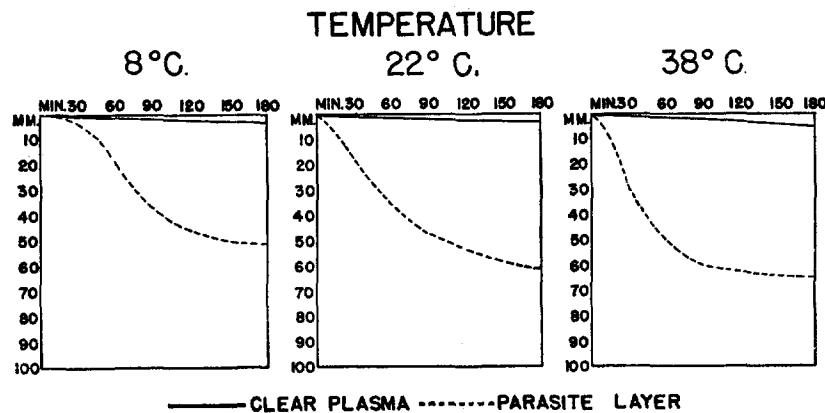

TEXT-FIG. 2. Differential sedimentation in hematocrit tubes at different temperatures of whole parasitized blood containing *Plasmodium knowlesi*. The whole blood contained 22.4 per cent parasites. After sedimentation for 1 hour at the three temperatures, the upper parasite or "feathery" layer contained 38 per cent, 79.5 per cent, and 89 per cent parasites in the order given above.

the blood and thus the integrity of the parasitized cell is maintained. De-fibrinated blood was not used because the clear demarcation between layers does not occur without centrifugation.

The phenomenon of differential sedimentation of *P. knowlesi* appears to depend on a series of physical and chemical changes taking place in the parasitized host cell and the plasma of the blood. As the parasite grows in the host cell, the erythrocyte changes from the normal disc shape to that of a spherocyte. These spherocytic parasitized cells are usually slightly crenated and they float free of the normal red cells and seldom enter into the formation of rouleaux. Thus, the rouleaux sediment faster than the parasitized cells, giving clear cut layers of plasma at the top of the column of blood, then the "feathery" or parasite layer, and then the layer of normal red cells with a small percentage of parasitized cells at the bottom of the column. Obviously,

the lower the total of parasitized cells, the lower the yield of concentrated parasites will be. If the blood sample contains a majority of parasites in the ring or young trophozoite stage of development, the relative yield is small also (Experiment 32, Table III). This is to be expected because the young parasite has not changed the physical and chemical properties of the cell sufficiently.

Changes in the properties of blood plasma and quantities of blood proteins during acute and chronic malaria are well known (Ghosh and Sinton, 43, Boyd and Proske, 44, and Kopp, 45). The reduction of plasma proteins, the reversal of globulin-albumin ratio resulting from the drop in albumin and increase in globulin, and the lowered surface tension have some effect on producing the increased sedimentation rate (Kehar and Harbhagwan, 46) and hence on the differential sedimentation of red cells containing *P. knowlesi*. To show that this increased and differential sedimentation was a property of the altered plasma and also changes in the host red cell, three controlled replacement experiments were performed with normal plasma. When plasma in parasitized whole blood with 19.2, 38.4, and 14 per cent parasites respectively was replaced with normal plasma, the following results were obtained: Experiment 1—read at 1 hour—sedimentation rate of feathery layer in normal plasma was 14.2 per cent, Experiment 2—read at 1 hour—was 41 per cent, and experiment 3—read at 2 hours—was 20 per cent of rate in parasitized plasma. These clear cut results demonstrate the changed properties of parasitized plasma but the specific differences were not studied further. The fact that heparinized blood from an acute malarial infection will sediment differentially in 20 minutes and that defibrinated blood fails to give distinct layers in the same time, suggests that fibrinogen also plays a part in this process just as it does in the sedimentation rate of human blood (Ham and Curtis, 47).

The practical usefulness of the above method for the concentration of *P. knowlesi* gave some hope that the method could be used for human parasites also. Since the concentration, properties, and morphology of the human species of malarial parasites are specifically different and the physiological and morphological changes in the host red cells appear to be different, it is not surprising that the method failed and other methods had to be sought. A method for concentration of *P. vivax* is reported elsewhere (Ferrebee and Geiman, 48).

#### *Apparatus for Cultivation of Parasites*

As was pointed out in a previous paper (24), any attempt to grow parasites *in vitro* must make provisions for an adequate supply of glucose and for buffering against pH changes resulting from lactic acid production by both the parasite and the normal red cell. The metabolic characteristics of parasitized blood are such that this can only be accomplished by an appreciable dilution of the

blood with a buffered isotonic nutrient medium or by the continual addition of glucose and removal of lactic acid from the blood by dialysis against a suitable nutrient medium. Over and above these basic requirements, it seemed reasonable to suppose that various other growth factors might be required. The construction of an adequate nutrient medium was thus a prime requisite in an approach to the problem of cultivation. After extensive experimentation, a successful nutrient medium was devised; reasons for the inclusion of its various ingredients and the details concerning its preparation will be given in a subsequent paper (49).

Two different techniques have been perfected for the cultivation of malarial parasites. One, which we have named the rocker-dilution technique, consists of diluting parasitized blood with a nutrient medium (see reference 49 for composition). The other, named the rocker-perfusion technique, employs a cellophane membrane to separate whole parasitized blood from the nutrient medium. Several types of apparatus for each technique have been employed and will now be described.

In the rocker-dilution technique, one part of a parasitized blood sample is diluted with three parts of the nutrient medium and placed in a suitable vessel in which the gas phase can be maintained by continuous flow during incubation at 38–39°C. The parasitized blood sample is a mixture of parasitized blood (usually 10 per cent parasitized cells or higher), and normal monkey blood made in such proportions that 1 cc. of the final culture mixture contains approximately 16 millions of parasites. This number may be varied from 13 to 20 million, depending upon the time of incubation, but the number should not exceed 16 million per cc. for a 24 hour period. This limitation on number of parasites is imposed because experiments have shown that three parts of our nutrient medium will adequately support one part of whole blood for a period of 24 hours without adverse pH changes only when its initial parasite population is no higher than that given. An obvious remedy to this limitation on parasite number might seem to be an increase in the amount of diluting medium. We have found, however, that when the serum protein content of the fluid surrounding the red cell is lowered below 25 per cent of its normal value, adverse physical changes in the red blood cell occur during the incubation period. Moreover, the number of parasites and dilution of red cells employed is of the order of magnitude which is practical in making initial parasite counts that are valid for quantitative purposes.

It should be pointed out that the dilution of parasitized blood with normal blood serves important purposes other than the control of parasite numbers. First, it provides the culture with an excess of normal, healthy red blood cells for reinvasion and multiplication of the plasmodia. Second, it also provides unknown growth factors which are not in the synthetic medium. This aspect will be dealt with in greater detail in the following paper (49).

The rocker-dilution technique was carried out originally in a 40 cc. heavy duty centrifuge tube provided with a rubber stopper containing two glass tubes for maintenance of gas phase. Later a special container or "boat" (Text-fig. 3) was designed for this method of cultivation. A cylindrical pyrex vessel is flattened on the bottom to stand upright and is equipped on top with tubes for gas ports at each end and with a central port of such length to permit flaming for sterile handling. For sterilization the two gas ports of the vessel are plugged with cotton, the central port is plugged with gauze-encased cotton, and the entire tube is then wrapped in heavy paper. Sterile vessels are prepared for filling by exchanging the central cotton plug for a sterile No. 1 rubber stopper. The parasite blood mixture (1.5 cc.) is usually added first and then the culture medium (4.5 cc.) or other ingredients such as drugs may be added.

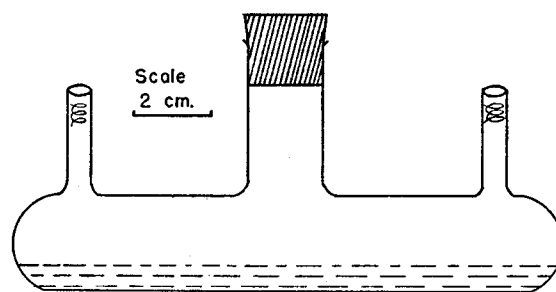

TEXT-FIG. 3. Diagram of the rocker-dilution vessel used for the cultivation of malarial parasites. The two openings at the ends are for the maintenance of gas phase and the larger central opening, closed by a rubber stopper, is for the introduction of the parasitized blood and nutrient medium. The total volume of blood and medium used is 6 cc.

The size of the vessel is such that 6 cc. of solution covers the bottom to a depth of about 3 mm. exposing a large liquid surface for rapid equilibration with the gas phase. This is a 5 per cent  $\text{CO}_2$ -95 per cent air mixture which is supplied from a commercial tank and bubbled through an isotonic NaCl solution before entering one of the gas ports on the culture vessel. When a series of vessels is being run, we have connected the exit port of one vessel with the inlet port of another. The gas leaving the final vessel is bubbled through a shallow water trap which also serves to indicate the rate of gas flow. A flow of gas in the neighborhood of one bubble per second is customary. This gas mixture is not a regular commercial product, but can be obtained commercially upon request. The regular commercial 5 per cent  $\text{CO}_2$ -95 per cent  $\text{O}_2$  mixture cannot be used because it inhibits parasite growth (*cf.* 49). During incubation, the vessels are rocked mechanically on a platform at a rate of about one cycle every 3 seconds. The vessels are mounted at a slight angle to the long axis of the rocker platform to produce a continuous, mild turbulence in the ves-

sel so that the red cells are kept suspended. Larger volumes than 6 cc. of the blood and nutrient mixture may be used if a container providing greater surface is employed.

A variation of this technique, known as the rocker-dilution agar technique, is also useful when one desires to maintain the pH and nutrients for longer life of the cultures. The nutrient medium is incorporated in melted agar at 45°C. by adding double strength synthetic medium to an equal volume of 2 per cent agar made with double distilled water. Thirty cc. of the nutrient agar is placed in a 50 cc. Erlenmeyer flask, a rubber stopper with ports for gas exchange is inserted, and the flask is placed in the refrigerator to set. In 1 to 2 hours the flask is removed and 6 cc. of a parasite-medium mixture is placed on the agar surface for incubation. These cultures have a higher ratio of medium to blood (25:1) and hence the pH is maintained nearer to the original 7.4 for a longer period of time. The cultures are rocked and gas phase is maintained by the same method as that described above.

The rocker-perfusion technique was designed to use whole heparinized or defibrinated blood separated by a cellophane membrane from a source of nutrients. The cellophane membrane provides for an interchange of the permeable components of the medium and the blood. Two modifications of this technique have been employed. The first type of apparatus (Text-fig. 4) was designed to contain a volume (10 to 15 cc.) of parasitized blood sufficient for chemical studies on parasites grown *in vitro*. It provides for a continuous flow of the nutrient medium through cellophane tubing immersed in the blood. It is composed of three parts, a reservoir, a flow regulator, and a culture vessel which are connected with rubber tubing and are sterilized as a unit in an autoclave.

The reservoir (Fig. 4A) for the medium consists of a 2 liter Erlenmeyer flask when the cultivation period is of 24 hour duration, or of a correspondingly larger flask for longer periods. Through the rubber stopper of this flask pass four pieces of glass tubing. Two of these, fitted with cotton plugs for maintenance of sterility, are used to equilibrate the medium with CO<sub>2</sub> gas after its sterilization. A third (Text-fig. 4A 2) is fitted with a vaccine port for the introduction of components of the medium not sterilized with the bulk of the solution, *i.e.*, vitamins, etc. The fourth leads through a flow regulator (Text-fig. 4B) to the culture vessel.

The reservoir is connected by rubber tubing to a coil of glass capillary tubing which acts as a flow regulator. This coil is made from tubing 72 cm. in length with a capillary bore 0.5 mm. in diameter. It is equipped with a rubber tubing by-pass as shown in Text-fig. 4B, which may be clamped off. When the total head of the reservoir is about 2 feet, this coil permits the flow of about 1500 cc. of medium in 24 hours. Variations in the flow rate may be achieved by raising or lowering the reservoir which is mounted on a movable shelf.



We have tried various methods for regulating the flow of a sterile medium including a roller type of pump but the method described here has been the simplest and most satisfactory.

The culture vessels (Text-fig. 4 C) are made by cutting the flared edge from a 250 cc. beaker and adding a port at the base into which a rubber vaccine port can be inserted to allow sterile entry with a syringe and needle. Through this

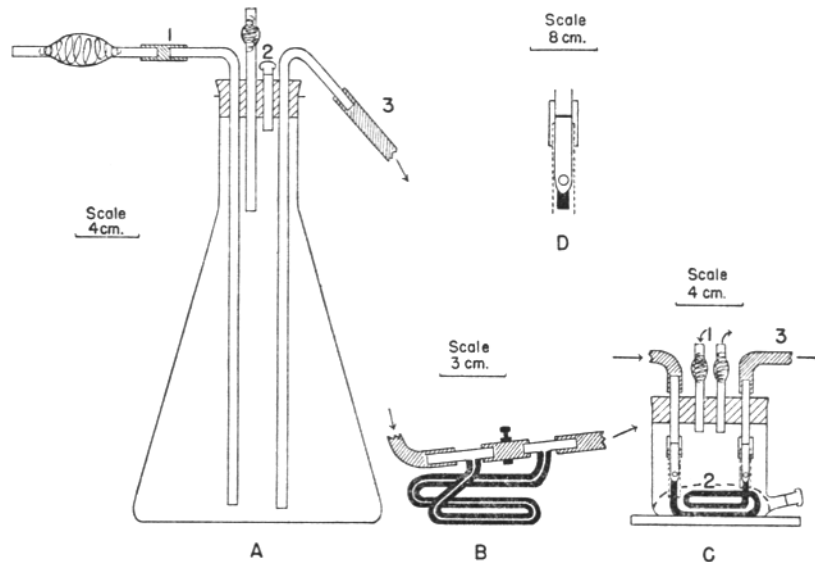

TEXT-FIG. 4. Diagram of the perfusion apparatus, type 2, for the cultivation of malarial parasites. Part A is the vessel which serves as the reservoir of medium, part B is the capillary drip to control the flow of the medium, part C is the vessel which holds the parasitized blood for cultivation, and part D shows the details of joining the coil of cellophane casing to the inlet and outlet tubes of vessel C. A detailed description of the assembly, sterilization, and use of this apparatus is given in the text.

port, the sterile vessel is loaded with the blood sample and, from time to time during incubation, samples are withdrawn for study. The vessel is closed at the top with a rubber stopper containing four holes, two for the inflow and outflow of the medium and two (Text-fig. 4 C 1) to be used for the maintenance of gas phase.

The medium enters the culture vessel through one of the glass tubes in the stopper, passes through cellophane tubing<sup>2</sup> (8/32 in. inflated diameter and 18 in. long) which is threaded on a coiled solid glass rod (3 mm. in diameter) template, and leaves the vessel by the other glass tube (Text-fig. 4 C 3) to

<sup>2</sup> Purchased from the Visking Corporation, 6733 West 65th Street, Chicago 38, Illinois.

empty into a collecting bottle not shown in the diagram. The coils of the glass template are concentric and lie in a plane parallel and close to the bottom of the culture vessel. The bulk of the cellophane tubing is thus held in a coiled position fitting loosely around the template near the bottom of the culture vessel, so that it is immersed in the blood sample. Extending upward from the glass coils and at right angles to their plane are two arms of solid glass rod which terminate in glass tubing with an outside diameter nearly equal to that of the bore of the cellophane tubing. The cellophane tubing which fits snugly over this glass tubing is securely tied to it at both ends with heavy white button and carpet thread. The glass coil with its cellophane jacket is joined to the inlet and outlet tubes inserted in the stopper by rubber tubing in such a way that the rubber tubing overlaps the cellophane tubing and helps to secure it in place (Text-fig. 4 D). On the glass coil near both points of junction of the rod and tubing, there is a small hole in the wall of the glass tubing. It is through these holes that the medium enters and leaves the cellophane casing surrounding the solid glass coils.

The blood in the culture vessel is exposed to a five per cent  $\text{CO}_2$ -95 per cent air mixture which enters and leaves the vessel by glass tubes which are plugged with cotton before sterilization to prevent contamination during cultivation. The rate of flow and handling of the gas mixture is the same as described for the rocker-dilution method. Care must be taken to balance inflow and outflow of gas, so that excessive pressure is not built up in the culture vessels which are mounted in tandem on a platform usually in a series of three to six. Though the gas mixture flows from one vessel to another, each vessel has its own reservoir and flow regulator. The vessels are mounted and rocked on the same platform as that used for the rocker dilution technique.

The three pieces of the apparatus are joined together by suitable lengths of pure gum rubber tubing which have been thoroughly cleaned and autoclaved before use. We have found that the type of tubing employed and its cleanliness are important factors if good results are to be obtained.

Before autoclaving the medium is placed in the reservoir of the assembled apparatus and the vaccine ports on the reservoir and culture vessel are tightly covered with a gauze and paper cap.

Screw clamps are also placed on the tubing at the places labeled C 3 and A 1 and A 3 in Text-fig. 4. The clamps at A 1 and A 3 prevent loss of fluid from the reservoir during sterilization, while the clamp at C 3 prevents subsequent contamination of the culture vessel through the exit port. After autoclaving for 30 minutes, the unit is allowed to cool to approximately  $38^\circ\text{C}$ . and then the clamp at A 1 is opened and pure carbon dioxide is bubbled through the solution in the reservoir to dissolve the precipitate of carbonate and phosphate which has formed. Components of the medium that were sterilized by filtration through glass filters (see reference 49 for details) are then added

through the vaccine port of the reservoir. The solution is finally equilibrated with a 5 per cent CO<sub>2</sub>-95 per cent air mixture to bring back its pH to 7.4. In some experiments only the basic salt solution was sterilized by autoclaving in the reservoir and all the organic components of the medium were sterilized by filtration. In these experiments, the vaccine port on the reservoir was replaced with a larger tube which could be flamed before and after the addition by pipette of the various filtered components of the medium.

The sterilized unit is placed in a constant temperature room maintained at 38-39°C., the reservoir placed on a movable shelf, and the culture vessel mounted on the rocking platform. With a slight gas pressure applied to the reservoir through A 1, and the clamp on the by-pass of the flow regulator, B, open, the clamp at C 3 is removed. About 20 to 30 cc. of medium is allowed to flush through the system and then the by-pass is clamped off causing the medium to run through the capillary coil of the flow regulator. The height of the reservoir is then adjusted so that the rate of flow of the medium is about 1 cc. per minute. The covering over the vaccine port on the culture vessel is then removed and a 12 to 15 cc. blood sample introduced, care being taken not to puncture the cellophane tubing with the syringe needle. After all vessels are loaded, the platform is set in motion.

With this type of apparatus, it is possible to use blood with a higher initial percentage of parasitized cells than in the rocker-dilution technique. In one experiment, for example, 13.2 per cent of the blood cells introduced initially were parasitized. At the end of 20½ hours, the parasite population had increased so that 44.3 per cent of all cells present were parasitized.

Although the type of apparatus just described is essential when large amounts of blood are needed for chemical studies, a smaller type of perfusion apparatus has been devised which combines the best features of the dilution and perfusion techniques. The type of apparatus finally adopted is shown in Text-fig. 5. The vessel is somewhat similar in design to the rocker-dilution "boat," but of larger size so as to accommodate a greater volume of medium. One port (2, Text-fig. 5) on the vessel is designed for the sterile introduction of the medium and for the entry of the CO<sub>2</sub>-air gas mixture. It carries a one-hole No. 3 rubber stopper which is fitted with a glass tube plugged with cotton. At the other end, (4, Text-fig. 5), is a smaller port, also plugged with cotton which serves as the outlet for the gas mixture. The central and largest port carries a rubber stopper which acts as a support for a piece of glass tubing (5, Text-fig. 5), 1.8 cm. in diameter and 8.5 cm. in length. This tubing is closed at one end with a No. 1 solid rubber stopper and over the other end, which is flanged, is tightly stretched a cellophane membrane (3, Text-fig. 5). The piece of cellophane which is cut from cellophane tubing (5.5 cm. diameter) is closed around the outside of the tubing and securely tied in place at two levels with strong white button and carpet thread. The lower tie is made just behind

the head of the flange and the upper around the top of the cellophane which extends to just below the hole (6, Text-fig. 5) in the tubing wall which serves for gas equilibration of the blood samples to be held within this tubing.

For sterilization of the apparatus, the rubber stoppers inserted at ports 2 and 5 in Text-fig. 5 are replaced with cotton plugs wrapped in gauze, and the rubber stoppers sterilized separately. When using the apparatus for cultivation, approximately 30 cc. of nutrient medium is introduced by way of port 2 and about 0.5 cc. of parasitized blood mixed as described under the rocker-dilution technique is laid on top of the cellophane membrane by way of port 5.

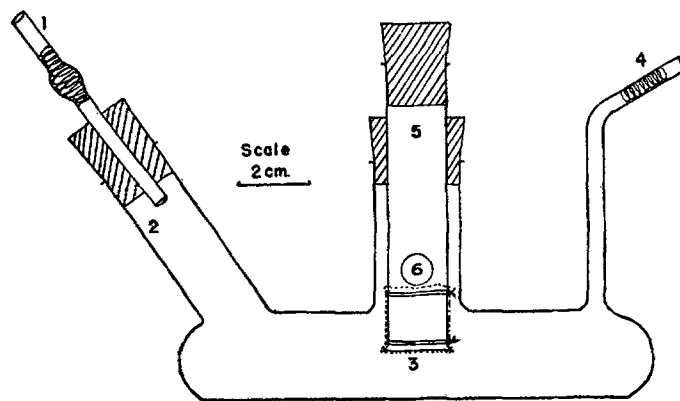

TEXT-FIG. 5. Diagram of the perfusion vessel, type 1, used for the cultivation of malarial parasites. The vessel, somewhat similar to the rocker-dilution "boat," has been modified to contain a larger volume of medium which bathes the cellophane membrane separating the medium and the blood being cultivated. A detailed description of the assembly, sterilization, and use of this apparatus is given in the text.

The sterile rubber stoppers for these ports are then inserted. If the parasitized blood to be cultured is heparinized, then heparin should be added to the nutrient medium also. Whole blood, plasma, or serum, etc., may also be added to the medium as desired. The vessel is mounted on a rocking platform and connected to a CO<sub>2</sub>-air gas mixture in the same manner as described for the rocker-dilution apparatus. Care must be taken to adjust the glass tube carrying the cellophane membrane so that it is about half submerged by the nutrient medium only when the vessel is at the point of greatest tipping on the rocker. If the membrane is completely submerged at all times, a marked dilution of the blood sample results.

This type of apparatus is easy to assemble, sterilize, and handle with sterile technique. Although the quantity of blood in the membrane is too small for extensive biochemical studies, the method is very satisfactory for studies on growth, nutrition, and particularly for prolonged cultivation and subculture.

The ratio of blood to nutrient medium of 1:60 is a distinct advantage for the maintenance of physiological conditions necessary both for the survival of red cells and for the normal growth and multiplication of malarial parasites. In both types of perfusion apparatus, the rate of passage of crystalloids across the cellophane appears to be adequate on the basis of glucose analyses.

In employing any of the techniques described above strong emphasis must be placed on the careful planning and close coordination of taking the blood for cultivation, preparation of media, and setting up cultures in the various types of apparatus. For the best results, the media and the vessels should be prepared for use before the blood is drawn for cultivation. A minimum of time and handling of the blood between the animal and the incubating culture vessel will ensure the best results.

TABLE IV

*Multiplication of P. knowlesi during a 20 to 24 Hour Period by Different Culture Methods*

Culture method	Total experiments	No. of experiments with the amount of multiplication								Average multiplication
		2X	3X	4X	5X	6X	7X	8X	9-11X	
Rocker-dilution.....	131	28	41	19	14	11	8	6	4	4.1
Perfusion, type 1.....	51	7	15	12	8	3	5	1		4.1
Perfusion, type 2*.....	53	12	17	12	7	4	1			3.6
Total, all types.....	235	47	73	43	29	18	14	7	4	3.9

\* This method of cultivation makes use of the continuous flow of nutrient medium through the blood being cultivated.

#### *Results of Cultivation Experiments*

A summary of results obtained using the three techniques is given in Table IV.

Here in a total of 235 experiments multiplication ranged from two to elevenfold with an average value of 3.9 for the three types of apparatus. These figures do not include the subculture experiments but only the short term experiments involving the segmentation of one generation of parasites and reinvasion of new red cells. Data on the progress of growth and multiplication of *P. knowlesi* using the various techniques have already been given in a previous paper (25). The appearance of the parasites at different intervals of cultivation is shown here in Figs. 2-4.

At first glance it may seem surprising that on the average the least multiplication is obtained in the rocker-perfusion apparatus type 2, where a continuous flow of fresh nutrient medium is maintained throughout the cultivation period. It should be pointed out, however, that in this type of apparatus

any dialyzable component of whole blood not present in the nutrient medium will gradually be removed—whereas, in the other type of apparatus, it will be merely diluted. Thus, the perfusion apparatus type 2 is useful for experiments designed to determine the essential or accessory nature of various nutrients. The other types of apparatus have been used to study the various aspects of the utilization of substrates and the effects of antimalarial drugs. Evidence that the nutrient medium employed still lacks some blood constituents favorable for growth is presented in the following paper (49). A subsequent paper will deal with the *in vitro* effects of antimalarial drugs.

#### SUMMARY

1. Methods of recovering adequate amounts of *Plasmodium knowlesi* from the monkey (*Macaca mulatta*) for biochemical studies and *in vitro* cultivation are described.

Concentrates of red blood cells parasitized with *P. knowlesi* can be obtained by differential sedimentation of parasitized blood because of physical and chemical changes produced by the parasites in the host cell and the plasma of the blood.

2. Two different techniques, the rocker-dilution and the rocker-perfusion methods, are described for the cultivation of malarial parasites. Details of the apparatus, assembly, and sterilization are given, as well as methods of counting and evaluating parasites.

3. In a series of 235 control experiments for 20 to 24 hours using three types of apparatus, the average rate of multiplication was 3.9. Each technique has specific value for studying the various aspects of metabolism, nutrition, and the action of antimalarial drugs.

#### BIBLIOGRAPHY

1. Laveran, A., *Bull. Acad. méd.*, Paris, 1880, **9**, 1235, 1268, 1346.
2. Thayer, W. S., and Hewetson, J., *Johns Hopkins Hosp. Rep.*, 1895, **5**, 3.
3. Bass, C. C., and Johns, F. M., *J. Exp. Med.*, 1912, **16**, 567.
4. Bass, C. C., *Am. J. Trop. Dis. and Prevent. Med.*, 1913–1914, **1**, 546.
5. Thomson, J. G., and Thomson, D., *Ann. Trop. Med. and Parasitol.*, 1913, **7**, 509.
6. Trager, W., *J. Exp. Med.*, 1941, **74**, 441.
7. Trager, W., *J. Exp. Med.*, 1943, **77**, 411.
8. Coulston, F., *J. Parasitol.*, 1941, **27**, suppl., 38.
9. Hawking, F., *Tr. Roy. Soc. Trop. Med. and Hyg.*, 1945, **39**, 245.
10. Huff, C. G., and Bloom, W., *J. Infect. Dis.*, 1935, **57**, 315.
11. James, S. P., and Tate, P., *Parasitology*, 1938, **30**, 128.
12. Hegner, R., and Wolfson, F., *Am. J. Hyg.*, 1939, **29**, Sect. C, 83.
13. Gavrilov, W., Bobkoff, G., and Laurencin, S., *Ann. Soc. Belge Med. Trop.*, 1938, **18**, 429.
14. Rodhain, J., Gavrilov, W., and Cowez, S., *Compt. rend. Soc. biol.*, 1940, **134**, 261.

15. Paraense, L., Meyer, H., and Menezes, V., *Rev. Brasil Biol.*, 1942, **2**, 89.
16. Beltran, E., *Rev. Inst. Sal. y Enferm. Trop.*, 1942, **3**, 217.
17. Hawking, F., *Lancet*, 1944, **1**, 693.
18. Huff, C. G., and Coulston, F., *J. Infect. Dis.*, 1944, **75**, 231.
19. Eichorn, E. A., *Science*, 1940, **92**, 245.
20. Wolfson, F., *Am. J. Hyg.*, 1940, **32**, Sect. C, 60.
21. Stauber, L. A., and van Dyke, H. B., *Proc. Soc. Exp. Biol. and Med.*, 1945, **58**, 125.
22. Haas, V. H., and Ewing, F. M., *Pub. Health Rep., U.S.P.H.S.*, 1945, **60**, 185.
23. Haas, V. H., Feldman, H. A., and Ewing, F. M., *Pub. Health Rep., U.S.P.H.S.* 1945, **60**, 577.
24. McKee, R. W., Ormsbee, R. A., Anfinsen, C. B., Geiman, Q. M., and Ball, E. G., *J. Exp. Med.*, 1946, **84**, 569.
25. Ball, E. G., Anfinsen, C. B., Geiman, Q. M., McKee, R. W., and Ormsbee, R. A., *Science*, 1945, **101**, 542.
26. Waisman, H. A., Rasmussen, A. F., Jr., Elvehjem, C. A., and Clark, P. F., *J. Nutrition*, 1943, **26**, 205.
27. Waisman, H. A., and Elvehjem, C. A., *J. Nutrition*, 1943, **26**, 361.
28. Waisman, H. A., and McCall, K. B., *Arch. Biochem.*, 1944, **4**, 265.
29. Waisman, H. A., McCall, K. B., and Elvehjem, C. A., *J. Nutrition*, 1945, **29**, 1.
30. Shaw, J. A., Phillips, P. H., and Elvehjem, C. A., *J. Nutrition*, 1945, **29**, 365.
31. McKee, R. W., and Geiman, Q. M., *Proc. Soc. Exp. Biol. and Med.*, in press.
32. Coggeshall, L. T., and Kumm, H. W., *J. Exp. Med.*, 1937, **66**, 177.
33. Coggeshall, L. T., and Eaton, M. D., *J. Exp. Med.*, 1938, **68**, 29.
34. Aberle, S. D., Primate Malaria, National Research Council Monograph, March, 1945.
35. Beck, R. C., Laboratory Manual of Hematologic Technic, Philadelphia, W. B. Saunders Company, 1938.
36. Drinker, C. K., Field, M. E., and Ward, H. K., *J. Exp. Med.*, 1934, **59**, 393.
37. Augustine, D. L., *J. Infect. Dis.*, 1941, **69**, 206.
38. Mulligan, H. W., *Arch. Protistenk.*, 1935, **84**, 285.
39. Wintrobe, M. M., Clinical Hematology, Philadelphia, Lea & Febiger, 1942.
40. Wilcox, A., and Logan, L., Symposium on Human Malaria, (F. R. Moulton, editor), The American Association for the Advancement of Science, Lancaster, The Jaques Cattell Press, 1941, No. 15, 47.
41. Field, J. W., and Le Fleming, H., *Tr. Roy. Soc. Trop. Med. and Hyg.*, 1939, **32**, 467.
42. Gingrich, W., *J. Prevent. Med.*, 1932, **6**, 197.
43. Ghosh, B. N., and Sinton, J. A., *Rec. Malaria Survey India*, 1935, **5**, 173.
44. Boyd, M. F., and Proske, H. O., *Am. J. Trop. Med.*, 1941, **21**, 245.
45. Kopp, I., *J. Lab. and Clin. Med.*, 1942, **27**, 1072.
46. Kehar, N. D., and Harbhagwan, S. A. S., *Rec. Malaria Survey India*, 1937, **7**, 131.
47. Ham, T. H., and Curtis, F. C., *Medicine*, 1938, **17**, 447.
48. Ferrebee, J. W., and Geiman, Q. M., *J. Infect. Dis.*, 1946, **78**, 173.
49. Anfinsen, C. B., Geiman, Q. M., McKee, R. W., Ormsbee, R. A., and Ball, E. G., *J. Exp. Med.*, 1946, **84**, 607.

## EXPLANATION OF PLATES

## PLATE 23

FIG. 1. A concentrate of *Plasmodium knowlesi* obtained by differential sedimentation of heparinized blood containing 23.4 per cent parasites. These concentrates are used for *in vitro* and biochemical studies.



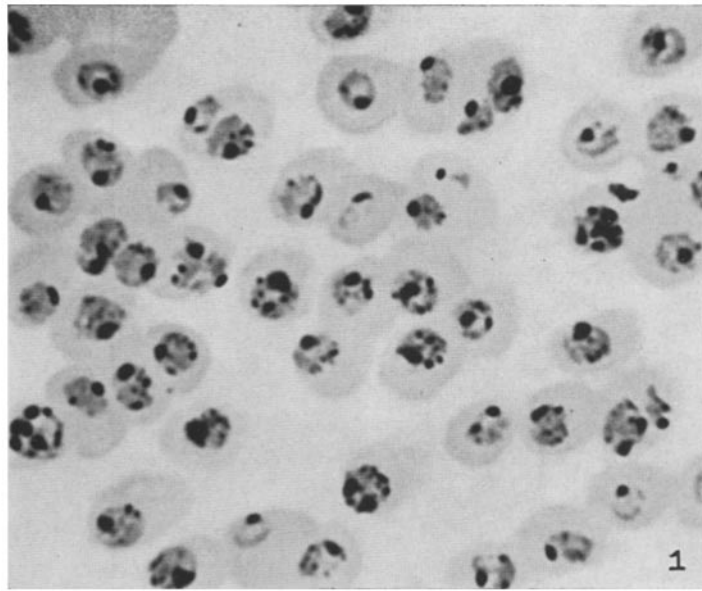

(Geiman *et al.*: Studies on malarial parasites. VII)

PLATE 24

Photomicrographs ( $\times 1500$ ) of *P. knowlesi* grown by the rocker-perfusion technique, type 2.

FIG. 2. Appearance of the parasites in the blood at the beginning of cultivation. The whole blood, which was used in this technique, contained 4.34 millions of red cells with 3.6 per cent parasitized. Seventy-five per cent of the parasites were trophozoites and 25 per cent were schizonts.

FIG. 3. Appearance of the parasites at  $10\frac{1}{2}$  hours. Segmentation and reinvasion are almost complete. The parasites have multiplied to 15.6 per cent with 92 per cent "ring" stages or very young trophozoites.

FIG. 4. Appearance of the parasites at  $21\frac{1}{2}$  hours. Growth has progressed, normal cytoplasmic mass is being achieved in the parasites, and schizogony is beginning. The percentage is now 15.7 and a 4.3-fold increase has occurred.

