

# Comparison of Physical and Genetic Properties of Palindromic DNA Sequences

GARETH J. WARREN\* AND ROBERT L. GREEN

*Advanced Genetic Sciences, Inc., Oakland, California 94608*

Received 10 August 1984/Accepted 30 November 1984

Some viable palindromic DNA sequences were found to cause an increase in the recovery of genetic recombinants. Although these palindromes contained no Chi sites, their presence in *cis* caused apparent *recA*<sup>+</sup>-dependent recombination to increase severalfold. This biological property did not correlate with the physical properties of the palindromes' extrusion of cruciform structures *in vitro*. Thus, two unrelated palindromes with similar effects on recombination in both *Escherichia coli* and *Pseudomonas syringae* displayed quite different kinetics of cruciform formation. In plasmids of native superhelical density, one palindrome underwent rapid cruciform formation at 55°C, whereas the other did not form detectable cruciforms at any temperature. A shorter palindrome with similarly rapid kinetics of cruciform formation did not affect recombination detectably. The lack of a clear relationship between physical and genetic properties was also demonstrated in the case of longer, inviable palindromes. Here we found that the degree of asymmetry required *in vivo* to rescue a long palindrome from inviability far exceeded that required to kinetically prohibit cruciform extrusion *in vitro*.

Interest in the biological properties of palindromic DNA stems from the prediction that it should be capable of adopting a cruciform structure (9), as an alternative to the more usual DNA secondary structure of a linear double helix. Electron microscopy has been used to confirm directly its potential to adopt cruciform structures (22). Two other types of experiment have been carried out to examine the formation of cruciforms *in vitro*. Cruciform extrusion by very short palindromes has been assayed by enzymatic or chemical cleavage of the cruciform. Cleavage by S1 nuclease (16, 23), by T4 endonuclease VII (21, 19), or via bromoacetaldehyde modification (18) has indicated that in some palindromes, cruciform extrusion can occur at temperatures below 37°C. However, the low pH encountered in some experiments might facilitate cruciform extrusion, as might the actual binding of the nucleases. Cruciform extrusion by palindromes longer than 40 base pairs (bp) can be monitored without DNA cleavage because the process results in a detectable change in the electrophoretic mobility of the carrier plasmid. These experiments have indicated that the transition is thermodynamically favored, but may be kinetically insignificant at physiological temperatures (7, 8). This would suggest that the generation of cruciforms *in vivo* would require catalysis by cellular proteins, and we cannot at present predict the occurrence of this from *in vitro* data. Courey and Wang (7) looked for cruciforms in the DNA of a palindrome-containing plasmid after careful extraction from the cell; they found only the same low levels as those obtained in a control procedure on purified DNA. Sinden et al. (25) attempted to "fix" cruciforms existing *in vivo* by trimethylpsoralen cross-linking, yet were unable to detect such forms in extracted DNA. Therefore neither predictions from *in vitro* work nor direct examination of cellular DNA has provided evidence for cruciform formation *in vivo*.

However, the biological effects of long palindromic sequences in DNA would appear to indicate that palindromes have properties that depend on their unique structural (non-coding) potentials, such as the potential to adopt cruciforms.

(Other theoretical potentials include the ability to give rise to double-stranded RNA species.) Such long palindromes (most of those tested are of total length greater than 800 bp) display *recA*<sup>+</sup>-independent instability (illegitimate recombination being increased by several orders of magnitude [5, 6]) and inviability in all strains tested (10, 11, 15, 22). Lilley (17) demonstrated that a shorter palindrome (260 bp) could not be cloned in *Escherichia coli*, but whether this was due to inviability or to instability is not clear. The *recBC*<sup>-</sup> *sbcB*<sup>-</sup> genetic background was reported to increase the stability of viable imperfect palindromes (6) and to confer viability on a shorter (and possibly imperfectly symmetrical) palindrome of about 300 bp cloned in phage lambda (15).

In this report we describe another genetic phenomenon attributable to palindromic DNA. It involves palindromes that are short enough to be viable in every strain tested and that do not display the instability associated with longer palindromes. Their stability and viability facilitate the study and quantitation of their effects *in vivo* and thus permit a comparison of their biological and physical properties.

## MATERIALS AND METHODS

**Bacterial strains.** Except for RGP1, the bacterial strains were derivatives of *E. coli* K-12, with genotypes as follows: AB1157, *ara galK his lacY leuB mtl proA rpsL supE thi thr tsx*; JC2926, like AB1157, but also *recA13*; JC10291, like AB1157, but also  $\Delta(recA-srl)303$ ; JM83, *ara  $\Delta lac-pro rpsL thi$   $\phi 80 d lacZ \Delta M15$* ; SK1592, *hsdR thi gal endA sbcB tonA*. RGP1 is derived from a natural isolate of *Pseudomonas syringae* pathovar *syringae* by a single mutation to rifampin resistance.

**Plasmid constructions.** Refer to Fig. 1. Plasmid pGJ68 was constructed by ligating together the kanamycin resistance (Km<sup>r</sup>)-conferring *Hind*III-*Bam*HI fragment of Tn5 (present in pGJ53 [10]) and the ampicillin resistance (Ap<sup>r</sup>)-conferring *Hind*III-*Bam*HI fragment of pAT153 (27). pGJ106 was constructed by ligating together the chloramphenicol resistance (Cm<sup>r</sup>)-conferring *Eco*RI-*Hind*III fragment of pKT210 (2) and the Ap<sup>r</sup> Km<sup>r</sup>-conferring fragment of pGJ68. Plasmid pGJ128 was constructed by ligating together *Eco*RI-linearized

\* Corresponding author.

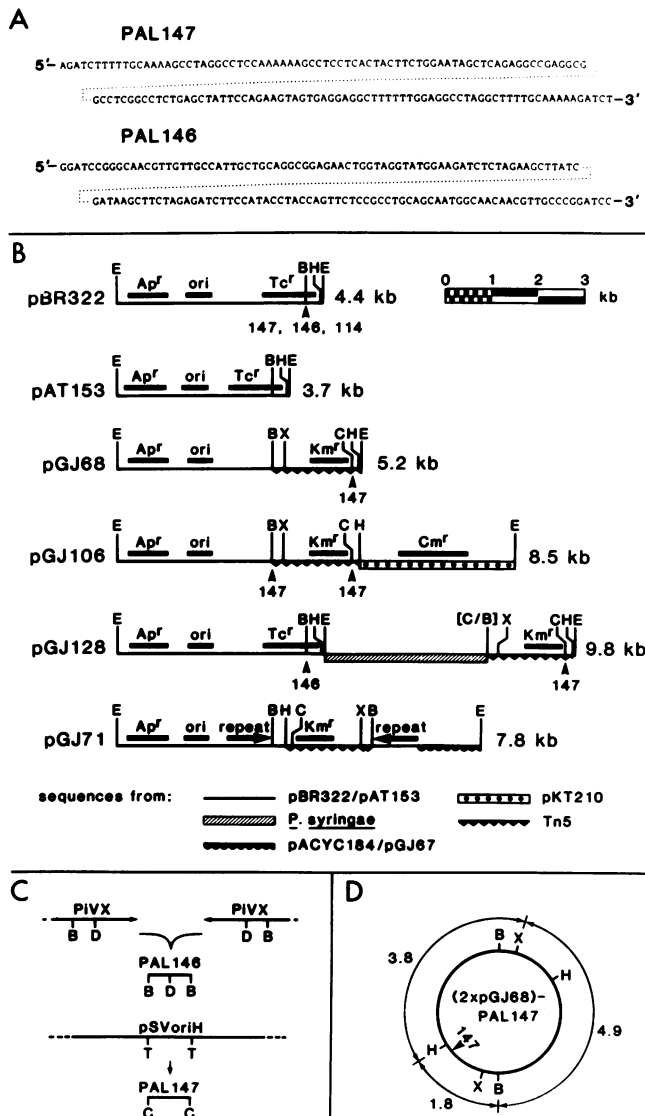

FIG. 1. (A) Sequences of the larger two palindromes are presented here for convenient reference. All bases are shown; the dotted lines indicate continuity. (B) Maps indicate derivations of plasmids used in the text. Numbers in bold type below each map indicate the positions at which corresponding palindromes were inserted. Abbreviations: B, *Bam*HI; C, *Bgl*II; C/B, site of *Bgl*II-*Bam*HI fusion; E, *Eco*RI; H, *Hind*III; X, *Xho*I. (C) Derivations of the larger two palindromes. Abbreviations: D, *Cl*aI; T, *Sau*3A. (D) Depiction of the fragments ligated in the construction of (2xpGJ68)-PAL147.

pBR322, the small *Eco*RI-*Bam*HI fragment of pGJ68, and a 3.5-kilobase (kb) *Eco*RI-*Bgl*II fragment from plasmid pGJ87. (The 3.5-kb fragment in pGJ87 was cloned from an *Eco*RI-*Bgl*II digest of the genome of *P. syringae* pv. *syringae*.) Plasmid pGJ71 was constructed by ligating together the larger *Eco*RI-*Hind*III fragment of pGJ67 (11) and the larger *Eco*RI-*Hind*III fragment of pAT153 (27), creating a 7.8-kb *Km*<sup>r</sup> *Ap*<sup>r</sup> plasmid in which a *Bam*HI fragment encoding *Km*<sup>r</sup> is bounded by inverted repeats of approximately 950 bp.

The source of the 147-bp palindromic DNA sequence was plasmid pSVoriH (4), from which a 141-bp palindromic fragment was released by digestion with *Sau*3A (Fig. 1C). This fragment was excised from a 5% polyacrylamide gel

after electrophoresis. It was cloned into the *Bam*HI site of pBR322 and the *Bgl*II sites of pGJ68, pGJ106, and pGJ128 to form the plasmids designated pBR322-PAL147, pGJ68-PAL147, pGJ106-PAL147, and pGJ128-PAL147, respectively. A second copy of the 141-bp fragment was cloned into the *Bam*HI site of pGJ106-PAL147 to form pGJ106-(2xPAL147). The 146-bp palindrome was generated in plasmid pBR322-PAL146 by insertion into the *Bam*HI site of pBR322 of two copies of the 70-bp *Bam*HI-*Cl*aI fragment of plasmid PiVX (24) (Fig. 1C). A 140-bp fragment was released from pBR322-PAL146 by *Bam*HI digestion and cloned into the *Bam*HI sites of pRK404 (G. Ditta, personal communication) and pGJ128 to form plasmids pRK404-PAL146 and pGJ128-PAL146. pBR322-PAL114 was derived from pBR322-PAL146 by deletion of a 32-bp *Bgl*II fragment.

(2xpGJ68)-PAL147 was constructed by ligating together three gel-purified restriction fragments: the 4.9-kb *Bam*HI-*Xho*I fragment of pGJ68, the 3.8-kb *Xho*I-*Hind*III fragment of pGJ68, and the 1.8-kb *Hind*III-*Bam*HI fragment of pGJ68-PAL147 (Fig. 1D).

**DNA preparation.** The DNA preparation method of Holmes and Quigley (12) was followed. In the tests of cruciform formation (see below), we performed additional treatments to remove cruciforms immediately before each experiment, as follows. To each preparation we added ethidium bromide to a concentration of 0.2  $\mu$ g/ml; the mixtures were then cooled from 25 to 0°C and extracted three times against ice-cold water-saturated phenol containing 0.1% hydroxyquinoline. (Phenol extracts ethidium bromide much more efficiently than does *N*-butanol.) DNA was next precipitated by the addition of 0.1 volume of 3.3 M sodium acetate and 2 volumes of ethanol at -15°C and taken up in electrophoresis buffer. The superhelicalities of pBR322 and its derivatives were compared by electrophoresis on gels containing 8  $\mu$ g of chloroquine per ml.

**Restriction enzyme cleavage, ligation, and transformation.** Restriction enzyme cleavage, ligation, and transformation were as described by Mizuuchi et al. (22). DNA samples were dialyzed extensively against TE (10 mM Tris, 1 mM EDTA, pH 8.0) both before and after ligase treatments. Ligase-treated samples were transformed into strain SK1592, except for the use of JM83 as indicated below. Extraction of DNA from agarose gels was as described by Hagan and Warren (11).

**Agarose gel electrophoresis.** The buffer for electrophoresis was 40 mM Tris-20 mM sodium acetate-1 mM EDTA adjusted to pH 8.2 with acetic acid. Chloroquine was added, where specified, to the molten agarose just before pouring. One-dimensional gels were 1% agarose (Seakem), unless for preparatory purposes, when 0.7% low-gelling-temperature agarose (Sigma Chemical Co.) was used. They were run for 16 h in a potential gradient of 1.5 V/cm at 25°C. For two-dimensional gels 1% agarose containing 4  $\mu$ g of chloroquine per ml was used. Gels 3.5 mm deep were formed on a 150- by 150-mm horizontal glass plate. Samples were loaded into a rectangular 1.5- by 5-mm well in one corner. The first dimension was run in the direction of the long axis of the well, submerged in buffer containing 4  $\mu$ g of chloroquine per ml, and held at 4°C under a potential gradient of 5 V/cm for 8 h. Chloroquine was removed by three 30-min washes in electrophoresis buffer. The gels were then incubated at 50°C for 20 min, cooled to 4°C, and inundated with chloroquine by two 30-min soakings in buffer containing 4  $\mu$ g of chloroquine per ml. The second dimension was run at right angles to the first under identical conditions. Chloroquine was removed by washing, and the gels were stained

with ethidium bromide and photographed under UV illumination.

**Densitometry.** Densitometry was performed with an E-C Apparatus densitometer (1983 model) on negatives (Polaroid type 55) photographed from one-dimensional agarose gels. Integration was performed by cutting out the area between the trace and the zero level and weighing the paper. The densitometer was coupled to a chart recorder so that a recorder trace over 10 cm of paper corresponded to 1 cm of negative scanned.

To calculate relaxation (see below), measurements were made on covalently closed circular monomer forms of plasmid DNA, all of which had run ahead of nicked circular monomers. A point of cutoff was assigned between the positions of the fastest and slowest covalently closed circular monomers, 2/5 of the range back from the position of the fastest forms. The traces ahead of and behind the cutoff point were integrated separately, and relaxation was calculated as follows: [integral (behind cutoff)]/[integral (behind cutoff) + integral (ahead of cutoff)].

In measurements of multimerization or resolution, gels did not contain chloroquine, so that cruciformed and non-cruciformed plasmids of each size ran close together. Peaks corresponding to nicked circular monomer bands (which ran slightly behind covalently closed circular dimers) were disregarded. When multimerization was calculated (see below) the integral of a multimer peak was divided by the sum of integrals of all visible multimer and monomer peaks. When resolution was calculated (see below) the integral of the monomer peak was divided by the sum of the integrals of monomer and dimer peaks only.

**Cloning of *Sau3A* fragments into pUC8, pGJ71, and pGJ53.** The *Bgl*II replicator fragment of pGJ53 was prepared as described by Hagan and Warren (11). The 5.4-kb *Bam*HI replicator fragment of pGJ71 was prepared similarly. Fragments from a complete *Sau3A* digest of pAT153 was ligated to the two replicators, with selection for Cm<sup>r</sup> and Ap<sup>r</sup> in the respective transformations. The same fragments were also cloned into pUC8 that had been linearized with *Bam*HI; here it was necessary to discriminate among transformants by including X-gal in the media and picking the white Lac<sup>-</sup> clones that result from insertions into pUC8 (29). Restriction analysis on 5% polyacrylamide gels was used to characterize the insertion lengths within plasmids produced by this protocol. To characterize pGJ53 derivatives, *Pvu*II was used; an insertion of *x* bp would give a fragment of *x* + 184 bp. Likewise, in pGJ71 derivatives, an insertion of *x* bp corresponded to an *Sph*I fragment of *x* + 382 bp; for pUC8 derivatives, an insertion of *x* bp corresponded to a *Pvu*II fragment of *x* + 300 bp. We made allowance for the cloning into pGJ71 of the *Sau3A* fragment containing the *Sph*I site of pAT153.

**RESULTS**

**Genetic properties of palindromes: inhibition of multimer formation.** The palindromes whose properties we investigated in detail are among the longest that have been cloned successfully in *E. coli*; their lengths were 147, 146, and 114 bp (see above for plasmid constructions). Length and dyad symmetry were the only similarities between the 147- and 146-bp palindromes, whereas the 114-bp insertion was derived from the 146-bp sequence by a central symmetrical deletion of 32 bp. Although when cloned in pBR322 they lacked the genetic properties observed previously for larger palindromes (namely, inviability and instability), the longer two of the three palindromes were found to possess a novel

property: they apparently inhibited the spontaneous plasmid multimerization that occurs in Rec<sup>+</sup> strains of *E. coli* (3). The 114-bp palindrome did not show this effect. Quantitative measurements were made by densitometry of photographic negatives from agarose gels (Table 1). We also noted that PAL146 and PAL147 each reduced the copy number of the pBR322 vector about threefold, whereas PAL114 had no effect (data not shown). Thus there might exist a causal relationship between the palindromes' effects on oligomer frequency distribution and on replication. We recloned the longer two palindromes into other plasmids of different sizes and copy numbers, and we found that the inhibition of multimer formation was always retained. Thus the effect was observed in a low-copy-number, P1-incompatible vector (pRK404) and in a ColE1-type vector whose monomer is the approximate size of a pBR322 dimer (pGJ106). It was also observed that the addition of a second palindrome to pGJ106-PAL147 caused a further decrease in multimerization. The *E. coli* K12 Rec<sup>+</sup> SbcB<sup>-</sup> strain SK1592 was used as host in these experiments because it usually gives higher levels of plasmid multimerization than does the standard Rec<sup>+</sup> strain AB1157 (unpublished results).

**Genetic properties: stimulation of dimer resolution.** When Tn3 is present in a plasmid, it appears to inhibit plasmid multimerization because it promotes the resolution of multimers back to monomers (1). We suspected and sought a similar cause for the inhibition of multimerization by palindromes. Plasmid dimers were isolated from agarose gels and cloned in the  $\Delta$ *recA* strain JC10291; their structures were verified by restriction analysis. Rates of dimer resolution (conversion to monomers) were measured after parallel transformations of dimers with and without palindromes into *recA*<sup>+</sup> (AB1157) and *recA13* (JC2926) strains of *E. coli*. Because some of the dimers were not completely stable in the  $\Delta$ *recA* strain from which DNA was isolated, it was not always possible to isolate dimeric plasmids uncontaminated by monomers. Therefore, transformations into AB1157 and JC2926 were carried out at low DNA concentration to ensure the entry of no more than one plasmid copy per competent cell. Cells transformed by a dimer give rise to clones containing a proportion of plasmid dimers higher than those transformed by a monomer in control experiments.

TABLE 1. Multimerization results<sup>a</sup>

| Plasmid           | Dimer (%) | Higher multimers (%) |
|-------------------|-----------|----------------------|
| pBR322            | 14.8      | <1.2                 |
| pBR322-PAL114     | 19.4      | 1.6                  |
| pBR322-PAL146     | 4.9       | <1.2                 |
| pBR322-PAL147     | 0.9       | <0.8                 |
| pGJ68             | 25.4      | 4.7                  |
| pGJ68-PAL147      | 7.5       | 0.7                  |
| pRK404            | 23.2      | 2.2                  |
| pRK404-PAL146     | 9.5       | <3.0                 |
| pGJ106            | 28.6      | 14.8                 |
| pGJ106-PAL147     | 13.1      | 1.7                  |
| pGJ106-(2xPAL147) | 4.9       | 0.2                  |

<sup>a</sup> Multimerization of plasmids with and without palindromes. Each test is grouped together with its appropriate control. Every result is the mean of four densitometric measurements. DNA for these measurements was extracted from single clones of strain SK1592 that had been transformed with pure monomeric DNA of the appropriate plasmid (extracted from  $\Delta$  *recA* strain JC10291).

TABLE 2. Resolution results

| Expt           | Plasmid           | % Monomers from:                    |                         |
|----------------|-------------------|-------------------------------------|-------------------------|
|                |                   | AB1157 ( <i>recA</i> <sup>+</sup> ) | JC2926 ( <i>recA</i> 3) |
| A <sup>a</sup> | 2xpBR322          | 6.3                                 | <1.0                    |
|                | 2x(pBR322-PAL114) | <2.1                                | <2.3                    |
|                | 2x(pBR322-PAL146) | 67.6                                | 7.5                     |
|                | 2x(pBR322-PAL147) | NM <sup>b</sup>                     | NM                      |
|                | 2xpGJ106          | 16.2                                | 0.25                    |
|                | 2x(pGJ106-PAL147) | 59.3                                | 2.6                     |
|                | 2xpGJ68           | 3.8                                 | <1.6                    |
|                | 2x(pGJ68-PAL147)  | 32.3                                | 6.0                     |
| B <sup>c</sup> | pGJ106-(2xPAL147) | 0.5                                 | 0.6                     |
| C <sup>d</sup> | (2xpGJ68)-PAL147  | 28.7                                | 1.6                     |

<sup>a</sup> Resolution to monomers of dimeric plasmids with and without palindromes. Each test is grouped together with its appropriate control.

<sup>b</sup> NM, Not measured. These dimers resolved very rapidly in JC10291 (*ΔrecA*) after isolation from gels, and thus sufficiently enriched dimer populations were not available for transformation of AB1157 and JC2926.

<sup>c</sup> Resolution by recombination between palindromes in an otherwise nonrepetitive genome. The numbers for percent monomers here refer to the percentage of the resolution product, which was deleted for the segment between the palindromes.

<sup>d</sup> Resolution to monomers of a plasmid dimer with only one palindrome per dimeric genome.

DNA from such clones was used in the measurement of resolution rates. The monomeric contaminants of a dimer plasmid preparation would give rise to clones with the characteristically much lower proportion of dimers. DNA from such clones was discounted from resolution rate measurements.

The means of four independent measurements of resolution were taken to give each of the results in Table 2, experiment A. They show that the 147- and 146-bp palindromes increased dimer resolution of every plasmid tested severalfold in the *recA*<sup>+</sup> strain and increased resolution in the *recA*<sup>-</sup> strain up to detectable levels. By contrast, no such effects were detected for the 114-bp palindrome. We judge that these effects are sufficient to account for the alterations of oligomer frequency distribution described earlier. Resolution promoted by the longer palindromes appeared to be mostly, but not entirely, *recA*<sup>+</sup> dependent. The possibility that the detectable levels of resolution in the *recA*3 strain were due to leakiness of the *recA*3 mutation was ruled out by repeating the tests in a *ΔrecA* host, with a similar outcome (results not shown). We next tried to discover whether the resolution promoted by palindromes could be attributed to generalized homologous recombination, site-specific recombination, or both.

If site-specific recombination between palindromes were solely responsible for the effect on resolution, then (prediction 1) we would expect the presence of two palindromes at separate locations in the same plasmid to be sufficient to promote recombination at the previously observed levels. Other homology in *cis* would not be required. (This is true, for example, for the *res* sites of Tn3.) Also, we would not expect a single palindrome to promote the recombination of other sequences duplicated in tandem. In contrast, if generalized homologous recombination were the sole mechanism of resolution, then (prediction 2) the presence of two identical palindromes, in the absence of other sequence duplication should have little effect; moreover (as with Chi sites) we might expect one palindrome to be sufficient to promote the recombination of homologous sequences adjacent to it.

A plasmid named pGJ106-(2xPAL147) was constructed to test prediction 1; it contained two 147-bp palindromes 1.7 kb apart in an otherwise nonrepetitive molecule. It was tested for recombination between its two repeats, in the same way that dimer resolution was tested previously. Resolution (i.e., deletion of the segment between the palindromes) was detectable in *recA*<sup>+</sup> cells, but it was very low (Table 2, experiment B); thus site-specific recombination between palindromes cannot account for the high resolution rates of homologous dimers in *recA*<sup>+</sup> cells. However, in *recA*<sup>-</sup> cells, resolution of pGJ106-(2xPAL147) was at a level comparable to the resolution of homologous dimers; therefore recombination only between palindromes could account for the low levels of dimer resolution observed in *recA*<sup>-</sup>. A plasmid named (2xpGJ68)-PAL147 was constructed to test prediction 2. This was a dimer of pGJ68 in which only a single copy of the 147-bp palindrome was present. Its resolution was measured (Table 2, experiment C) and compared with the resolution of pGJ68 dimers and of pGJ68-PAL147 dimers, which are shown on the last lines of Table 2, experiment A. The test plasmid underwent resolution in *recA*<sup>+</sup> at levels similar to that of the pGJ68-PAL147 dimer and significantly much greater than that of the control pGJ68 dimer. This appeared to demonstrate that generalized homologous recombination, between pGJ68 repeats, accounts for the phenomena observed in *recA*<sup>+</sup> cells. In *recA*<sup>-</sup> cells the resolution of 2x(pGJ68-PAL147) was fourfold greater than that of (2xpGJ68)-PAL147; therefore two palindromes can act synergistically in promoting *recA*<sup>+</sup>-independent recombination. This observation does not clearly distinguish whether *recA*<sup>+</sup>-independent resolution is by generalized or site-specific recombination. Only the test of prediction 1 in *recA*<sup>-</sup> cells gives an indication that *recA*<sup>+</sup>-independent resolution is site specific.

**Genetic properties: cointegrate resolution in *P. syringae*.** If palindromes exerted their biological effects through their structural (noncoding) properties, it would be expected that they should have similar effects wherever nucleic acid metabolism was similar to that of *E. coli*. We tested the effect of 147- and 146-bp palindromes on recombination in the chromosome of *P. syringae*, which we were already studying in gene replacement experiments. Our control for the experiments in *P. syringae* was derived from plasmid pGJ128, which can replicate only in *E. coli*, but which contains approximately 3.5 kb of cloned *P. syringae* sequences. This plasmid was mobilized into *P. syringae* strain RGP1 by the R64*drd*11/pGJ28 system (28) with selection for Km<sup>r</sup>. The transconjugants contained a copy of the plasmid vector integrated by homologous recombination between its cloned 3.5 kb sequence and the corresponding region of the *P. syringae* chromosome. Our tests were derived from plasmid derivatives of pGJ128 into which the 147- or 146-bp

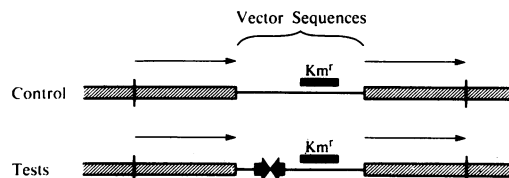

FIG. 2. Illustration of the genetic structure in the *P. syringae* chromosome after plasmid integration (not to scale). The long, direct arrows indicate the direct duplication of *P. syringae* sequences; the short, inverted arrows indicate the position of the palindrome.

palindrome had been inserted, but not within the 3.5-kb homology. These also were mobilized into strain RGP1. Southern blots confirmed that all transconjugants had analogous structures (Fig. 2; direct duplications of the 3.5-kb region flanked the  $Km^r$  plasmid replicon [with its associated palindrome in the test cases]). However, the frequency of obtaining such transconjugants was much lower where the integrating plasmid contained either palindrome (results not shown).

Excision of the integrated plasmid would be expected to occur by a second reciprocal, homologous recombination between the direct 3.5-kb duplications. Excision was assayed, after 20 generations of nonselective growth, by plating out to single colonies and screening for lack of  $Km^r$  by replica plating. Both palindromes caused an increase in the apparent frequency of recombination in adjacent homologous sequences, PAL147 having the greater effect (Table 3). This was consistent with previous results and therefore with the suggestion that palindromes exert their *in vivo* effects as structural rather than informational elements of DNA or RNA or both. (The 146- and 147-bp palindromes have no significant informational similarity; their longest mutual homology is only 6 bp. Also, neither contains the sequence GCTGGTGG [26], which has been identified as the determinant of Chi.)

**Measurements of cruciform extrusion *in vitro*.** Do palindromic sequences undergo transition to cruciform structures *in vivo*? Sinden et al. (25), Courey and Wang (7), and Gellert et al. (8) have concluded from *in vitro* work that they probably do not. The minimum temperatures required for cruciform extrusion *in vitro*, in plasmids with native negative superhelicities, were so high that the structural transition was deduced to be kinetically forbidden at physiological temperatures. We likewise investigated the transition temperature profiles of the palindromes whose biological properties we describe above. Our DNA isolation procedure yielded plasmids with superhelicities of approximately  $-0.05$  (see above) and mostly or entirely without cruciforms. (The absence of cruciforms was due to the positive supercoiling induced by ethidium bromide and the maintenance of low temperatures during its removal.) Samples of each plasmid dissolved in electrophoresis buffer were subjected to 5-min treatments at a range of temperatures and then analyzed for cruciform formation. The electrophoresis buffer contained a near-optimal cation concentration for cruciform formation (8) and allowed us to carry out comparable treatments *in situ* in agarose gels (see below).

Extrusion of a cruciform causes relaxation of negative superhelicity, and the degree of relaxation is set by the ratio of the extruded cruciform's length to the plasmid's contour length. This ratio was greater for our three substrates than for most of those studied by Mizuuchi et al. (22), Courey and Wang (7), and Sinden et al. (25), allowing increased separation between topoisomers containing and lacking cruciforms in one-dimensional electrophoresis through agarose. The

TABLE 3. Excision of integrated plasmids from the genomes of *P. syringae*<sup>a</sup>

| Integrated plasmid | Frequency of $Km^r$ clones (%) |
|--------------------|--------------------------------|
| pGJ128             | 0.03                           |
| pGJ128-PAL146      | 0.41                           |
| pGJ128-PAL147      | 3.2                            |

<sup>a</sup> Frequencies of plasmid excision, measured by loss of  $Km^r$ , from among cell populations grown for 20 generations in the absence of kanamycin selection. Each number is the mean of two independent measurements.

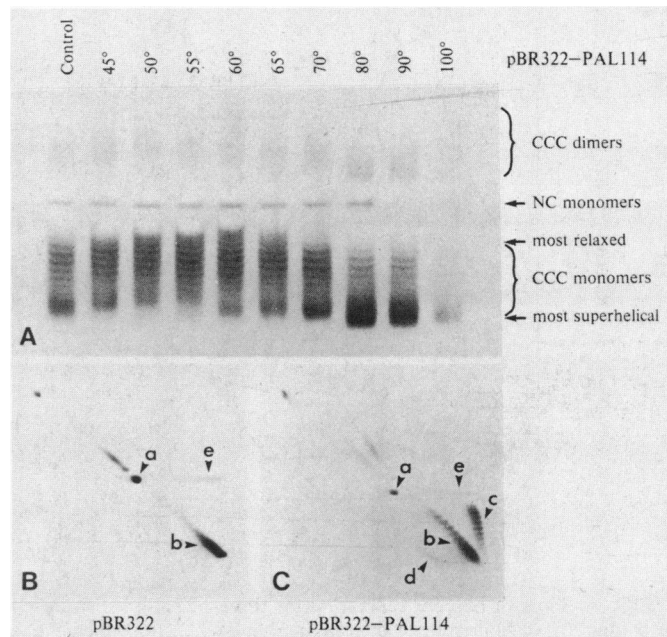

FIG. 3. (A) Sample result used in the calculation of relaxation of pBR322-PAL114 as a function of temperature (Fig. 4). NC, Nicked circular; CCC, covalently closed circular. (B and C) Two-dimensional gels with DNA of pBR322 and pBR322-PAL114, respectively. The first dimension was run left to right, and the second dimension was run top to bottom. Arrows: a, nicked circular monomers; b, covalently closed circular monomers that retained the same topology during electrophoresis in both dimensions (these therefore lie on a diagonal that intersects the point of origin [not shown]); c, covalently closed circular monomers that ran faster in the first dimension (noncruciformed) and slower in the second dimension (presumed cruciformed); d, covalently closed circular monomers that ran slower in the first dimension (presumed cruciformed) and faster in the second dimension (noncruciformed); e, monomers that ran with the mobility of covalently closed circular monomers in the first dimension and the mobility of nicked circular monomers in the second dimension. The absence of spur c with the pBR322 sample confirms that this effect depends on the presence of the palindrome in pBR322-PAL114. Two spurs can be seen relative to the main diagonal of pBR322-PAL114 dimers (upper left of gels); these we interpret as having undergone cruciform extrusion at one and at both palindromes, respectively, in the dimer.

intercalating agent chloroquine was used to maximize the relative differences in electrophoretic mobility. Then in spite of some remaining overlap between the mobilities of the least superhelical noncruciformed and the most superhelical cruciformed topoisomers, we were able to detect cruciform extrusion by comparing the degree of relaxation observed after different treatments. A sample result for pBR322-PAL114 is shown in Fig. 3A. We also performed a different kind of test for cruciform formation by pBR322-PAL114: untreated samples were subjected to electrophoresis in one dimension, heat treated to cause cruciform formation within the gel matrix, and subsequently run in the second dimension. Patterns were obtained which demonstrated the expected changes in electrophoretic mobility due to cruciform extrusion during the heating step (Fig. 3B).

Our measurements of plasmid relaxation at different temperatures are plotted in Fig. 4. Relaxation here is an artificial parameter that depends on an arbitrary choice for the position of cutoff (see above) and therefore does not directly measure the actual proportion of cruciforms (unlike methods described by Courey and Wang [7], Lilley [18], or Sinden et

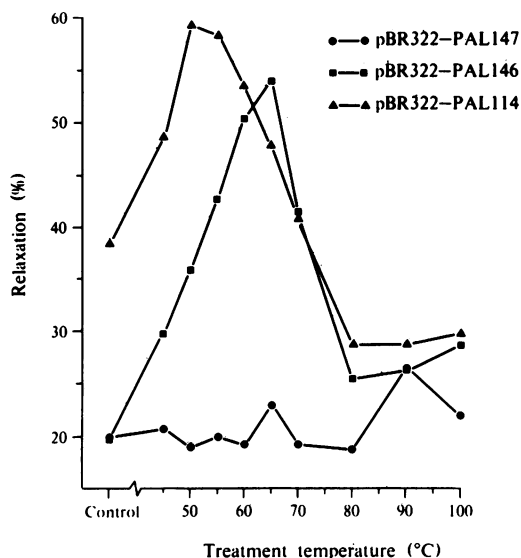

FIG. 4. Plots of percent relaxation for three plasmid substrates as a function of temperature of treatment. pBR322, for which the corresponding data are not shown, displayed a degree of relaxation that was constant within experimental error.

al. [25]). However, increases in relaxation will proportionately reflect similar increases in the numbers of cruciforms present, and the method permits rapid and sensitive measurement of such changes by comparison of different treatments on a single gel. The two palindromes PAL114 and PAL146 had similar temperature profiles; their relaxation increased with temperature up to an optimum temperature for each, above which relaxation again receded to the control level or below. By contrast PAL147 did not cause significant relaxation at any temperature up to and including 100°C. Parallel experiments on plasmid pBR322 showed no significant increase in relaxation at any temperature; this confirmed that the induced relaxation was associated with the presence of the palindromes. We also tested whether temperature-dependent relaxation could be reversed by the addition of saturating ethidium bromide and its subsequent removal at low temperature. The relaxation was indeed reversed, as would be expected for relaxation due to cruciform formation, but not due to other causes. Therefore we concluded that our relaxation test had been reflective of cruciform formation. Rapid cruciform extrusion apparently takes place in the 146- and 114-bp palindromes at temperatures above the physiological range. The reversal of cruciform extrusion at higher temperatures might be ascribed to the reduction in the winding ratio of DNA with increasing temperature (30). This reduction, by effectively lessening the negative superhelicity of plasmids, would shift an equilibrium between cruciform and duplex DNA in the observed direction. We cannot be certain that this is a full explanation of the high temperature reversal; however, it is convenient to view the temperature profile as the result of two distinct effects. A kinetic effect (increase in rate of achieving equilibrium with higher temperature) is opposed by the effect of a shifting equilibrium between cruciform and duplex structures.

We therefore also compared the kinetics of cruciform extrusion by the three palindromes at a single temperature. The chosen temperature of 55°C was below temperatures at which we judged that equilibrium reversal might prevent

cruciform formation by PAL147, while being high enough to promote rapid cruciform extrusion by the other palindromes. The time course of plasmid relaxation in this experiment is plotted in Fig. 5. We found that within 1.25 min, both pBR322-PAL146 and pBR322-PAL114 underwent significant increases in their degree of relaxation. By contrast pBR322-PAL147 had undergone no significant increase after 80 min. We conclude that cruciform extrusion by pBR322-PAL147 is at least 64-fold slower than that of the other palindromes under these conditions. The center of symmetry of the 147-bp palindrome is identical with the replication origin of simian virus 40; Lilley (personal communication) has been unable to detect S1 cleavage at this sequence in negatively superhelical DNA, in contrast to the demonstrable cleavage of every other short palindrome tested. Our result supports his conclusion that the simian virus 40 origin sequence has an anomalously high activation energy for cruciform extrusion *in vitro*. An alternative interpretation of our result would be that the pBR322-PAL147 substrate, although its apparent negative superhelicity when extracted from *E. coli* is equivalent to that of pBR322, is already in the cruciformed state. This would require that complete cruciform formation occurs *in vivo* and is subsequently compensated by renewed supercoiling. It would be surprising if pBR322-PAL147 differed from pBR322-PAL146 in this respect, since they replicate to similar copy numbers (see above). Also, molecules resulting from additional gyrase action should exhibit anomalous electrophoretic mobilities at concentrations of chloroquine that cause positive supercoiling, because of their anomalously low linking numbers. In practice, we detected no electrophoretic difference between pBR322-PAL146 and pBR322-PAL147 at high chloroquine concentrations.

**Role of sequences at the palindrome's center.** The relatively small size difference between the 114- and 146-bp palin-

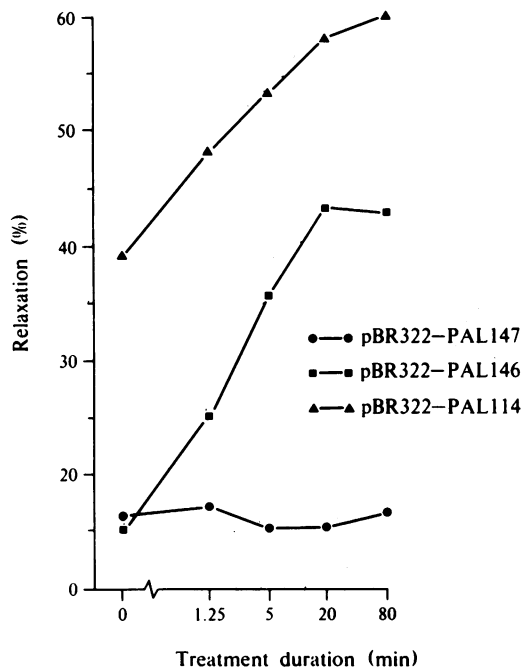

FIG. 5. Plots of percent relaxation for three plasmid substrates as a function of time (the temperature of each treatment was 55°C). Relaxation of pBR322 in a parallel test was constant within experimental error (data not shown).



dromes appeared to be critical for the observed biological property of the longer palindromes. If the same in vivo difference had been found between, for example, a 64- and a 96-bp palindrome, it would be easier to explain the difference in terms of the rapidity or irreversibility of cruciform formation. Therefore we speculated that the difference between the 114- and 146-bp palindromes is accentuated because, for a palindrome to exert genetic effects, there is a requirement is for symmetry in excess of 50 or so bp. This might be, for example, because the central 50 bp did not participate at all in the process causing the effects. The palindromes described above were unsuitable for testing this idea, because alterations in their central sequences would significantly reduce symmetry. The question was approached by manipulating palindromes already long enough that the addition of 50 or so base pairs at the center might not be considered to alter overall symmetry greatly. The biological property associated with such long palindromes is their inviability, which we presumed would depend on structural transitions in the same way as the recombination-stimulating property of the shorter palindromes.

Interrupting a long palindrome by introducing a central asymmetry creates a region that lacks the palindrome-specific property of self-complementarity. We tried to find the largest asymmetry that would still permit the palindrome to be lethal, because this should be the length of the central sequence, whose self-complementarity is not required for the genetic effect. We ligated a range of restriction fragments into the centers of palindromes derived from vectors pGJ53 and pGJ71. The fragment pool was obtained by *Sau3A* digestion of plasmid pAT153 (27), which gives 21 fragments with the following lengths: 8, 11, 12, 15, 17, 18, 27, 31, 36, 46, 75, 78, 91, 105, 258, 272, 317, 341, 359, 665, and 876 bp. DNA from about 140 transformants was examined in each experiment. A control, where the fragment pool was ligated into the plasmid pUC8, showed that fragments in each of the size ranges could be cloned into a nonpalindromic vector. This was not so for the tests: no palindromes were found interrupted by insertions in the lowest size ranges (Fig. 6). The smallest insertion into pGJ53 was 72 bp (a double insertion of the 46- and 36-bp *Sau3A* fragments); this plasmid was slightly unstable, generating deletions at a detectable rate. Likewise, the smallest insertion into pGJ71 was 57 bp (a double insertion of the 46- and 11-bp *Sau3A* fragments); this was highly unstable, generating a large proportion of deletions. In fact some instability could be detected in all insertions of less than 150 bp; this accords with the results of Collins et al. (6), who found similar instability in a viable palindrome with a central asymmetry of 70 bp. Our interpretation of these results is that central asymmetries of less than approximately 50 bp do not counter palindromic inviability, and those in the range of 50 to 100 bp may do so only partially. Therefore we suggest that the palindrome-specific phenomena observed in vivo require no special property of the central 50 bp.

## DISCUSSION

We have observed that some palindromic DNA sequences stimulate the recovery of genetic recombinants. What property of palindromes might cause this phenomenon? Two types of possibility may be distinguished. First, palindromes may be recombinogenic, for example, by acting as entry points for recombination enzymes. However, James et al. (14) described DNA elements that stimulated *recA*<sup>+</sup>-dependent plasmid recombination, and they all differed from palindromes in that they promoted plasmid multimerization

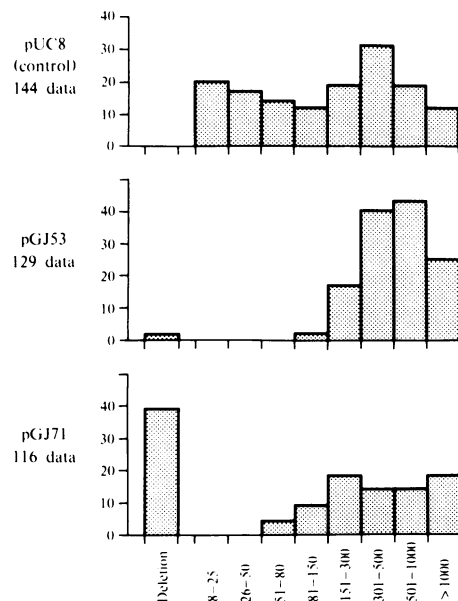

FIG. 6. Numbers of insertions obtained in the various size ranges with three vectors. The absence of insertions in certain size classes, in the palindromic vectors pGJ53 and pGJ71, is taken to indicate that plasmids with such insertions were formed, but did not survive after entry into competent cells (see the text).

(intermolecular recombination) as well as multimer resolution (intramolecular recombination). This encourages the second, alternative type of explanation, namely, that the palindromes' effects might result from the differential recovery of recombinant molecules, perhaps for reasons related to the previously identified phenomenon of palindromic inviability. It is conceivable that the same mechanism that causes complete inviability of a long palindrome could cause partial inviability of a shorter one. Indeed, the reduction in plasmid copy number associated with the 146- and 147-bp palindromes can be taken to support this idea. To explain the apparent stimulation of *recA*<sup>+</sup>-dependent recombination we would have to postulate additionally that a palindrome caused greater inviability in plasmid dimers than in plasmid monomers. Intracellular selection of plasmid monomers would then account for the accelerated production of monomers from dimers. However, this would not account for the low level of probably site-specific, *recA*<sup>+</sup>-independent recombination between palindromes. Such recombination might instead be related to the phenomenon of illegitimate, *recA*<sup>+</sup>-independent recombination which is stimulated by inviable longer palindromes (5, 6, 11).

No matter how the apparent effects on recombination are mediated, our results demonstrate that the cell recognizes the 146- and 147-bp palindromes, but ignores the 114-bp palindrome (and a number of shorter palindromes; unpublished data). The recognized palindromes are nonhomologous, whereas the ignored palindrome has homology to one of those recognized; therefore we presume that the distinction is made on the basis of size. This is consistent also with our inference that symmetry of the central 50 or so bp is not essential for the phenomenon of lethality in a long palindrome. It is difficult to see how palindromes could be recognized by the cell except through the formation of some type of foldback structure that their self-complementarity uniquely permits. A cruciform DNA is the simplest such

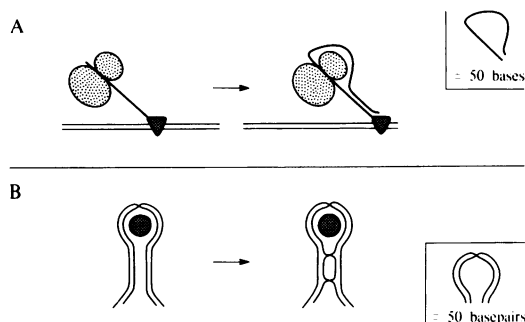

FIG. 7. Two possible models to explain the observation that the central 50 bp of a long palindrome need not be symmetrical for it to be inviable. (A) In this representation of transcription, the formation of an RNA foldback loop around a ribosome is postulated as the event that mediates inviability. The ribosome itself sequesters (speculatively) 50 bases, which is therefore the length of RNA wherein it is theoretically impossible for sequence asymmetry to impede the process. (B) The tightest possible *in vivo* foldback of DNA is depicted; the solid circle represents a double-stranded DNA-binding protein. The formation of a Holliday structure at such a foldback is postulated as the event which mediates inviability, and the DNA-binding protein sequesters (speculatively) 50 bp. Branch migration of such a Holliday structure could theoretically result in the creation of a cruciform.

structure: the formation of cruciforms has been demonstrated *in vitro* and will be discussed below. However, we first point out that other models are possible which not only invoke self-complementarity, but can also account for the inferred noninvolvement of the central bases. In both of the hypotheses depicted in Fig. 7, the central 50 bases are sterically restrained from participating in the initial formation of a foldback structure. These might be called "arm" pathways of structural transition, since the action is distant from the palindromic center. They contrast with the "center" pathway, whereby cruciforms can be formed *in vitro*, in which the structural change begins in a small sequence at the center of symmetry. The second possibility shown in Fig. 7 could explain the observations of Leach and Stahl (15), who found that a palindrome of approximately 300 bp became stable in a  $\text{RecBC}^- \text{SbcB}^-$  genetic background. It would be argued that the formation of an inviable structure (rather than its destruction, as suggested by the authors) was inhibited by the altered recombination specificity of this strain.

Can the phenomenon of recombination stimulation be accounted for by cruciform extrusion? The evidence accumulated in other laboratories probably indicates that different palindromes can have widely different temperature minima for the adoption of cruciform structure, some being within or below the "physiological" temperature range. This is not yet certain, since the palindromic centers studied by the different groups are nonidentical, as are the methods of measurement. The temperature profiles of cruciform formation described here certainly lend credence to the idea that palindromes can exhibit widely different kinetics of cruciform formation. Yet the 146- and 147-bp palindromes exert similar effects *in vivo*, whereas the 114-bp palindrome, which appears to undergo cruciform extrusion at least as readily as any other *in vitro*, has no detectable effect *in vivo*. Does this indicate that cellular proteins can catalyze cruciform extrusion, or that the effects are instead dependent on an "arm" pathway in which some other structure is created? Cellular catalysis of extrusion seems a strong possibility, but

the work of Sinden et al. (25) and Courey and Wang (7), who looked for cruciforms formed *in vivo*, provides no evidence for it. However, this lack of evidence is perhaps not relevant to the present discussion, since the palindromes in question were 66 and 68 bp in length; they were probably too short to display the biological effects that we discuss here. We are looking for cruciform formation *in vivo* by the 147-bp and 146-bp palindromes; so far we have failed to detect it, but we have been unable to attain a threshold of detection as low as that achieved by Courey and Wang. If cruciform formation is invoked to explain the phenomena of palindromic inviability and instability, it becomes even more clearly necessary to postulate a mechanism of cellular catalysis quite different from the "center" pathway responsible for extrusion *in vitro*. We have shown that it is necessary to insert a central asymmetry of at least 50 bp to restore viability, and a still greater asymmetry is required for stability. Yet from the calculations of Hsieh and Wang (13) it can be deduced that an asymmetry of no more than 20 bp should increase the activation energy of cruciform extrusion enough to provide a kinetic barrier against its occurrence at physiological temperatures.

Our studies have not provided evidence for cruciform extrusion by palindromes *in vivo*. They have associated a defined genetic phenomenon with palindromes, one which is more convenient for analysis than inviability or instability. Several explanations for it are possible. We have been able to conclude that if cruciforms are formed *in vivo*, they must do so by a process quite different from that which has been described *in vitro*.

#### ACKNOWLEDGMENTS

L. V. Corotto provided expert technical assistance. Graphic work was by C. Rubinstein and E. Crump. We are especially grateful to D. M. J. Lilley for communicating results before publication and for ideas and criticism. We also thank J. Jones and A. J. Clark for useful discussions and R. D. Kolodner and H. K. Dooner for critical comments on the manuscript.

#### LITERATURE CITED

- Arthur, A., and D. Sherratt. 1979. Dissection of the transposition process: a transposon-encoded site-specific recombination system. *Mol. Gen. Genet.* **175**:267-274.
- Bagdasarian, M., R. Lurz, B. Ruckert, F. C. H. Franklin, M. M. Bagdasarian, J. Frey, and K. N. Timmis. 1981. Specific-purpose cloning vectors. II. Broad host range, high copy number, RSF1010-derived vectors, and a host vector system for gene cloning in *Pseudomonas*. *Gene* **16**:237-247.
- Bedbrook, J. R., and F. M. Ausubel. 1976. Recombination between bacterial plasmids leading to the formation of bacterial multimers. *Cell* **9**:707-716.
- Bergsma, D. J., D. M. Olive, S. W. Hartzell, B. J. Byrne, and K. N. Subramanian. 1982. Cyclization of linear chimeric plasmids *in vivo* by a novel end-to-end joining reaction or by intramolecular recombination: one of the products contains a 147-bp perfect palindrome stable in *E. coli*. *Gene* **20**:157-167.
- Collins, J. 1981. The instability of palindromic DNA. Cold Spring Harbor Symp. Quant. Biol. **45**:409-416.
- Collins, J., G. Volckaert, and P. Nevers. 1982. Precise and nearly-precise excision of the symmetrical inverted repeats of Tn5: common features of *recA*-independent deletion events in *E. coli*. *Gene* **19**:139-146.
- Courey, A. J., and J. C. Wang. 1983. Cruciform formation in a negatively supercoiled DNA may be kinetically forbidden under physiological conditions. *Cell* **33**:817-829.
- Gellert, M., M. H. O'Dea, and K. Mizuuchi. 1983. Slow cruciform transitions in palindromic DNA. *Proc. Natl. Acad. Sci. U.S.A.* **80**:5545-5549.
- Gierer, A. 1966. Model for DNA and protein interaction and the



- function of the operator. *Nature (London)* **212**:1480-1481.
10. Hagan, C. E., and G. J. Warren. 1982. Lethality of palindromic DNA and its use in selection of recombinant plasmids. *Gene* **19**:147-151.
  11. Hagan, C. E., and G. J. Warren. 1983. Viability of palindromic DNA is restored by deletions occurring at low but variable frequency in plasmids of *E. coli*. *Gene* **24**:317-326.
  12. Holmes, D. S., and M. Quigley. 1981. A rapid boiling method for the preparation of bacterial plasmids. *Anal. Biochem.* **114**:193-197.
  13. Hsieh, T. S., and J. C. Wang. 1975. Thermodynamic properties of superhelical DNAs. *Biochemistry* **14**:527-535.
  14. James, A. A., P. T. Morrison, and R. Kolodner. 1983. Isolation of genetic elements that increase frequencies of plasmid recombinants. *Nature (London)* **303**:256-259.
  15. Leach, D. R. F., and F. W. Stahl. 1983. Viability of lambda phages carrying a perfect palindrome in the absence of recombination nucleases. *Nature (London)* **305**:448-451.
  16. Lilley, D. M. 1980. The inverted repeat as a recognizable structural feature in supercoiled DNA molecules. *Proc. Natl. Acad. Sci. U.S.A.* **77**:6468-6472.
  17. Lilley, D. M. J. 1981. *In vivo* consequences of plasmid topology. *Nature (London)* **292**:380-382.
  18. Lilley, D. M. J. 1983. Structural perturbation in supercoiled DNA: hypersensitivity to modification by a single-strand-selective chemical reagent conferred by inverted repeat sequences. *Nucleic Acids Res.* **11**:3097-3112.
  19. Lilley, D. M. J., and B. Kemper. 1984. Cruciform-resolvase interactions in supercoiled DNA. *Cell* **36**:413-422.
  20. Lilley, D. M. J., and A. F. Markham. 1983. Dynamics of cruciform extrusion in supercoiled DNA: use of a synthetic inverted repeat to study conformational populations. *EMBO J.* **2**:527-533.
  21. Mizuuchi, K., B. Kemper, J. Hays, and R. A. Weisberg. 1982. T4 endonuclease VII cleaves Holliday structures. *Cell* **29**:357-365.
  22. Mizuuchi, K., M. Mizuuchi, and M. Gellert. 1982. Cruciform structures in palindromic DNA are favored by DNA supercoiling. *J. Mol. Biol.* **156**:229-244.
  23. Panayotatos, N., and R. D. Wells. 1981. Cruciform structures in supercoiled DNA. *Nature (London)* **289**:466-470.
  24. Seed, B. 1983. Purification of genomic sequences from bacteriophage libraries by recombination and selection *in vivo*. *Nucleic Acids Res.* **11**:2427-2446.
  25. Sinden, R. R., S. S. Broyles, and D. E. Pettijohn. 1983. Perfect palindromic *lac* operator DNA sequence exists as a stable cruciform structure in supercoiled DNA *in vitro* but not *in vivo*. *Proc. Natl. Acad. Sci. U.S.A.* **80**:1797-1801.
  26. Smith, G. R., S. M. Kunes, D. W. Schultz, A. Taylor, and K. L. Trinan. 1981. Structure of Chi hotspots of generalized recombination. *Cell* **24**:429-436.
  27. Twigg, A., and D. Sherratt. 1980. Trans-complementable copy number mutants of plasmid ColE1. *Nature (London)* **283**:216-218.
  28. Van Haute, E., H. Joos, M. Maes, G. Warren, M. Van Montagu, and J. Schell. 1983. Intergeneric transfer and exchange recombination of restriction fragments cloned in pBR322: a novel strategy for the reversed genetics of the Ti plasmids of *Agrobacterium tumefaciens*. *EMBO J.* **2**:411-417.
  29. Vieira, J., and J. Messing. 1982. The pUC plasmids, an M13mp7-derived system for insertion mutagenesis and sequencing with synthetic universal primers. *Gene* **19**:259-268.
  30. Wang, J. C. 1969. Variation of the average rotation angle of the DNA helix and the superhelical turns of covalently closed cyclic lambda DNA. *J. Mol. Biol.* **43**:25-39.