

## SDS capillary gel electrophoresis of proteins in microfabricated channels

SHAO YAO\*, DEON S. ANEX†, W. BRETT CALDWELL\*, DON W. ARNOLD†, KATHERINE B. SMITH†,  
AND PETER G. SCHULTZ\*‡§

\*Department of Chemistry, Scripps Research Institute, La Jolla, CA 92037; and †Sandia National Laboratories, P.O. Box 969, M.S. 9671, Livermore, CA 94551

Contributed by Peter G. Schultz, March 12, 1999

**ABSTRACT** Analysis of variations in the concentrations or structures of biomolecules (e.g., mRNAs, proteins, peptides, natural products) that occur either naturally or in response to environmental or genetic perturbations can provide important insight into complex biological processes. Many biological samples are mixtures that require a separation step before quantitation of variations in the individual components. Two-dimensional denaturing gel electrophoresis has been used very effectively to separate complex mixtures of proteins, but it is time consuming and requires considerable amounts of sample. Microchannel-based separations have proven very effective in rapidly separating small amounts of nucleic acids; more recently, isoelectric focusing of proteins also has been adapted to the microchannel format. Here, we describe microchannel-based SDS capillary gel electrophoresis of proteins and demonstrate the speed and high resolution it provides. This development is an important step toward the miniaturization and integration of multidimensional and array separation methods for complex protein mixtures.

Methods for the direct measurement of changes in the concentrations and posttranslational states of proteins in complex biological systems are useful in analyzing protein function and identifying proteins of potential diagnostic or therapeutic value (1, 2). For a typical biological sample, the large number of different proteins present (up to thousands) and the small concentrations at which they can exist make such experiments difficult. Two-dimensional SDS/PAGE has proven to be a powerful tool for the profiling of protein expression (3). By combining isoelectric focusing for charge-based separation in one dimension and SDS/PAGE for size-based separation in a second dimension, hundreds to thousands of proteins have been resolved on a single two-dimensional SDS/PAGE slab gel (4, 5). Subsequently, chemical degradation and/or mass spectrometry can be used to identify the separated components. However, increased sensitivity and speed of detection would improve the ability to profile proteins on a routine basis significantly.

Improvements can be achieved by using capillary electrophoresis (CE), which offers many advantages for the separation of a wide variety of molecules. The method offers high efficiency, versatility, speed, and economy of analysis (i.e., very low consumption of reagents and analytes; ref. 6–22). Considerable effort also has been directed toward miniaturization in the field of CE—primarily in the adaptation of CE from capillaries to a planar microchannel format (9–19). Although chip-based CE allows better control of sample introduction and leads to better performance in terms of speed and efficiency, its greatest advantage lies in the opportunity to perform parallel-array (17) or multidimensional types of analyses. Conventional photolithography and microfabrication

technology enable these approaches by providing a means of fabricating channel structures of many different sizes and integrated devices on chips made of silicon, glass, quartz, plastics, or elastomers (12–16).

Among the known CE methods for protein analysis, capillary-zone electrophoresis has been performed in a microchannel-based format with some degree of success (18, 19). More recently, capillary isoelectric focusing has also been adapted to the chip format (20). SDS/PAGE (23) was demonstrated in a capillary over a decade ago (21). However, in spite of its importance as the most commonly used protein-separation method, it has not yet been adapted to the planar microchannel format. We demonstrate the on-chip application of a closely related size-dependent separation technique, SDS capillary gel electrophoresis (SDS/CGE). By transferring this method to planar microchannels, protein separations are accelerated by a factor of 20, and separation efficiencies typical of conventional capillary-based SDS/CGE experiments are retained.

### EXPERIMENTAL PROCEDURES

**Chemical Derivatization of Proteins.** All protein molecular mass (MM) markers (ranging from 9 kDa to 116 kDa) were labeled with 5- and 6-carboxyfluorescein succinimidyl ester (fluorescein-NHS) or fluorescein-5-maleimide (fluorescein-MAL) (Molecular Probes) following the manufacturer's protocols. Calmodulin,  $\alpha$ -lactalbumin, pepsinogen, egg albumin, BSA,  $\beta$ -galactosidase, and hen egg white lysozyme were purchased from Sigma. Calmodulin was obtained from Sigma with an uncharacterized MM. Its apparent MM (9 kDa) was determined experimentally by using an SDS/PAGE mini-gel. Staphylococcal nuclease 16-cys mutant was prepared as described (24). All other reagents were purchased from Aldrich, unless otherwise indicated.

For the fluorescein-NHS reactions, the protein was dissolved in a 0.2-M NaHCO<sub>3</sub> buffer (pH 8.3) to a final concentration of 1 mg/ml. Freshly prepared fluorescein-NHS solution (100  $\mu$ l of 10 mg/ml in DMSO) was slowly added to the protein solution, and the reaction was stirred in the dark for 1 h. The mixture (0.5 ml) was passed through a NAP-5 gel filtration column (Amersham Pharmacia) preequilibrated with H<sub>2</sub>O, and the fluorescein-labeled protein was eluted with 1 ml of H<sub>2</sub>O. Proteins were purified further by either (i) two more rounds of NAP-5 purification or (ii) overnight dialysis (MM cutoff = 3 kDa) into H<sub>2</sub>O at 4°C, followed by separation on a FPLC Mono Q column (Amersham Pharmacia; eluent of 0.01 M NaH<sub>2</sub>PO<sub>4</sub>, pH 7.0, with a gradient of 0–1 M NaCl over 30

Abbreviation: CE, capillary electrophoresis; CGE, capillary gel electrophoresis; MM, molecular mass; fluorescein-NHS, 5- and 6-carboxyfluorescein succinimidyl ester; fluorescein-MAL, fluorescein-5-maleimide.

‡To whom reprint requests should be addressed. e-mail: pschultz@lbl.gov.

§Present address: Department of Chemistry, 824 Latimer Hall, University of California, Berkeley, CA 94720-1460.

The publication costs of this article were defrayed in part by page charge payment. This article must therefore be hereby marked "advertisement" in accordance with 18 U.S.C. §1734 solely to indicate this fact.

min) and desalting of the desired fractions with Centricon columns (Amicon).

For the fluorescein-MAL reactions, the protein was dissolved in 100 mM sodium phosphate buffer (pH 7.0) to a final concentration of 100  $\mu$ M and then degassed under vacuum for 10 min. A freshly prepared fluorescein-MAL solution (20 equiv of 10 mM dye in DMSO) was slowly added to the protein, the reaction was stirred in the dark under  $N_2$  for 2 h, and then it was desalted with a NAP-5 column. The fluorescein-labeled product was purified further by using the Mono Q protocol described above. Identities of all fluorescein-labeled proteins were confirmed on the basis of their MM by using an SDS/PAGE mini-gel (Bio-Rad).

Calmodulin, hen egg white lysozyme, and the staphylococcal nuclease 16-cys mutant (100  $\mu$ M each) were treated with the two different dyes (fluorescein-NHS and fluorescein-MAL) as described above. Equimolar amounts of the three maleimide-labeled proteins were mixed to yield a sample of specifically labeled proteins. For comparison purposes, a similar sample of nonspecifically labeled proteins was prepared by mixing equimolar amounts of the three NHS-labeled proteins.

**Capillary-Based SDS/CGE.** All capillary-based SDS/CGE separations were performed by using a P/ACE 5000 capillary electrophoresis system (Beckman Coulter) with absorbance detection (214 nm) or laser-induced fluorescence detection (excitation at 488 nm; emission at 520 nm). Separations were performed by using an eCAP SDS 14-200 kit from Beckman Coulter with either an eCAP neutral capillary (27 cm  $\times$  100- $\mu$ m i.d.; Beckman Coulter) or an uncoated fused-silica capillary (27 cm  $\times$  100- $\mu$ m i.d.; Polymicro Technologies, Phoenix). The distance from inlet to the detection window was 20 cm.

Before each analysis, the capillary was conditioned with a series of pressure washes (20 psi; 1 psi = 6.89 kPa): (i) 1 M NaOH for 2.5 min; (ii)  $H_2O$  for 1 min; (iii) 1 M HCl for 1 min; (iv)  $H_2O$  for 1 min; and (v) SDS 14-200 gel buffer (Beckman Coulter) for 3 min. The performance of the instrument and the capillary was ensured by periodically testing with the Beckman Coulter protein test mix. The sample solution was prepared freshly by mixing 50  $\mu$ l of the protein mixture, 50  $\mu$ l of the SDS sample buffer (provided with the SDS 14-200 kit), and 3  $\mu$ l of  $\beta$ -mercaptoethanol and then by heating the mixture at 95°C for 3 min. The sample was injected into the capillary either electrokinetically (4 kV) or by pressure (20 psi). The separation voltage was 8.1 kV (300 V/cm) as recommended by the manufacturer. All voltage operations were performed in a reverse polarity mode (inlet at negative potential with respect to outlet).

**Chip Fabrication.** Chips were fabricated from borofloat glass wafers (4-inch diameter; 1-mm thickness; Schott Laboratories, Yonkers, NY) by using standard methods (17). The wafers were cleaned before the deposition of an amorphous silicon sacrificial layer (1,500 Å) in a plasma-enhanced chemical vapor deposition (PECVD) system (PEII-A, Technics West, San Jose, CA). After Piranha cleaning, the wafers were dried at 120°C for 5 min before being primed with hexamethyldisilazane, spin-coated with photoresist (Shipley 1818, Marlborough, MA) at 6,000 rpm for 30 s, and then soft baked at 90°C for 30 min. The mask pattern was transferred to the photoresist on the wafers by exposing the photoresist to UV radiation in a Quintel contact mask aligner. The photoresist was developed in a 1:1 mixture of Microposit developer concentrate (Shipley) and  $H_2O$ , followed by hard baking at 120°C for 25 min. The mask pattern on the photoresist then was transferred to the amorphous silicon by a  $CF_4$  plasma etch performed in the PECVD reactor. The wafers were etched in 49% (vol/vol) HF for different lengths of time at a vertical-etch rate of 7  $\mu$ m/min. The photoresist was stripped in a spin dryer, and the remaining amorphous silicon was removed with a  $CF_4$  plasma etch. Access holes (0.75 or 1.1 mm) were drilled

through the etched wafers by using diamond-tipped drill bits (Olympic Mountain Gems, Port Orchard, WA). An unetched Borofloat wafer was then thermally bonded, as a cover, to the etched channel wafer in an  $N_2$ -purged programmable furnace (Thermolyne, Dubuque, IA).

**Microchannel Layout for Chip-Based SDS/CGE.** Because of the high viscosity of the SDS 14-200 gel used in the separation, it was anticipated that a microchannel size comparable to that of a 100- $\mu$ m i.d. capillary would be needed for easy handling. Channels etched to a depth of 20  $\mu$ m proved to be too shallow for gel to pass through without frequent clogging. A 40- $\mu$ m-deep channel was found to be better and was used for all subsequent chip-based separations. The microchannel layout for chip-based SDS/CGE used in our experiments is shown in Fig. 1. The channel is 40  $\mu$ m deep, with a 100- $\mu$ m width at the top and a 20- $\mu$ m width at the bottom. The distances between reservoirs 1 and 4 and reservoirs 2 and 3 are 5 cm and 0.5 cm, respectively. Laser-induced fluorescence detection was typically performed 0.25 cm from reservoir 4, affording a separation channel 4.5 cm in length. In addition, the distances from 1, 2, and 3 to the cross-channel intersection are 0.25 cm each.

**Laser-Induced Fluorescence Detection for Chip-Based SDS/CGE.** The detection system for the chip-based SDS/CGE is shown schematically in Fig. 1. Similar epifluorescence/microscope-based detectors for microfabricated separation systems have been reported in the literature (25). Light from an argon-ion laser (Model 532, Omnichrom, Chino, CA) operating at 488 nm is passed through a bandpass filter and directed by a dichroic mirror through an aspheric lens (Model 5722-H-A, New Focus, Santa Clara, CA). The aspheric lens serves as a microscope objective (40 $\times$ ; 0.55 numerical aper-

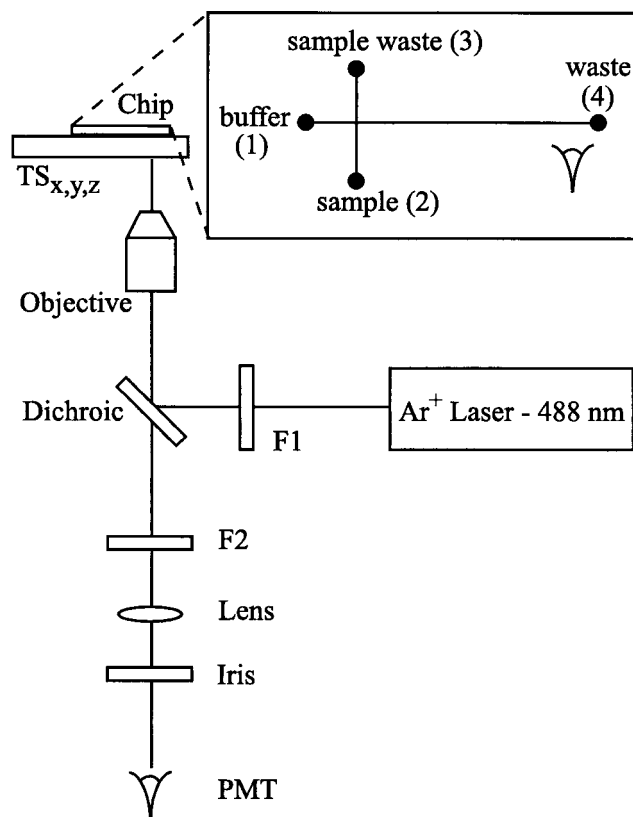

FIG. 1. Schematic of the instrumentation set up used for chip-based SDS/CGE separations. The microchannel layout used in the chip-based SDS/CGE separations also is shown. F1, excitation bandpass filter; F2, emission bandpass filter; PMT, photomultiplier tube;  $TS_{x,y,z}$ , x-y-z translational stage.

ture; 2.9-mm working distance), focusing the laser light into the separation channel and collecting the fluorescence. Collected light passes through the dichroic mirror and a bandpass filter centered on 535 nm with a 55-nm bandwidth. The filters and the dichroic mirror were purchased as a set (XF100 fluorescein filter set, Omega Optical, Brattleboro, VT). A 50-mm focal length lens (Spindler and Hoyer, Milford, MA) then focuses the emitted light through an adjustable iris onto a photomultiplier tube (Model HC-120-05, Hamamatsu, Bridgewater, NJ). A home-built power supply controls the photomultiplier tube bias and provides the power for an internal preamplifier. Output from the photomultiplier tube is sent to a personal computer via an interface (PCI-1200 DAQ card with a BNC-2081 board, National Instruments, Austin, TX), and the data are collected with a custom LABVIEW (National Instruments) program. A low-pass resistance-capacitance filter was used to reduce the high-frequency noise. The microfabricated separation chip is held in a x-y-z translator for positioning the detection region of the chip at the focus of the objective. High voltage to drive the separations is provided by 5-kV power supplies (SRS model PS350, Stanford Research, Sunnyvale, CA).

**Chip-Based SDS/CGE Separations.** Pipette tips were inserted into the drilled holes in the chip to serve as fluid reservoirs. All fluids used in the chip-based separation were prefiltered with 0.22- $\mu\text{m}$  syringe filters. Before sample loading, the channels first were cleaned and rinsed as follows: (i) 1 M NaOH for 1 min; (ii) H<sub>2</sub>O for 1 min (iii) 1 M HCl for 1 min; and (iv) H<sub>2</sub>O for 1 min. The SDS 14–200 gel was loaded into the channels by first filling reservoirs 1–3 with the gel and then applying a vacuum at reservoir 4 to pull the gel into the channels. Care was taken to ensure no air bubbles were introduced in the channels during gel loading. After the channels were filled completely, vacuum at reservoir 4 was removed and replaced with a pipette tip prefilled with gel. The gel in reservoirs 2 and 3 was removed subsequently and replaced with a 1:1 mixture of fresh SDS sample buffer and H<sub>2</sub>O. The channels were equilibrated by applying 200 V between reservoirs 2 and 3 and then 2 kV between 1 and 4, each for more than 5 min. Immediately before injection, the content of reservoir 2 was replaced with the protein sample (prepared as described earlier for the capillary-based separation). A simple floating injection (26) was used; an injection voltage (200 V) was applied between reservoirs 2 and 3 for 5–30 s to draw the sample across the cross-channel region, and then a separation voltage (1–5 kV) was applied between reservoirs 1 and 4. Because a stable current is necessary for good separations, current in the separation channel was monitored closely during the entire separation process. Data collection was performed at 400 Hz, with intervals of 10 points averaged to yield a rate of 40 points per s.

## RESULTS AND DISCUSSION

The main focus of this work is chip-based protein separations with SDS/CGE. However, for performance comparisons, both capillary-based and chip-based SDS/CGE separations were performed by using identical protein samples and separation media. Two types of labeled proteins were used in these experiments: proteins with multiple labels (nonspecifically labeled with amine-reactive fluorescein-NHS) and proteins with single labels (labeled specifically with the thiol-reactive dye fluorescein-MAL on a single cysteine in the protein sequence). We will refer to these proteins as “nonspecifically” and “specifically” labeled, respectively.

The first sample consisted of six fluorescently labeled proteins (ranging from 9 kDa to 116 kDa, see the legend in Fig. 2 for details). Calmodulin, which contains only one cysteine in its protein sequence, was labeled specifically and purified to

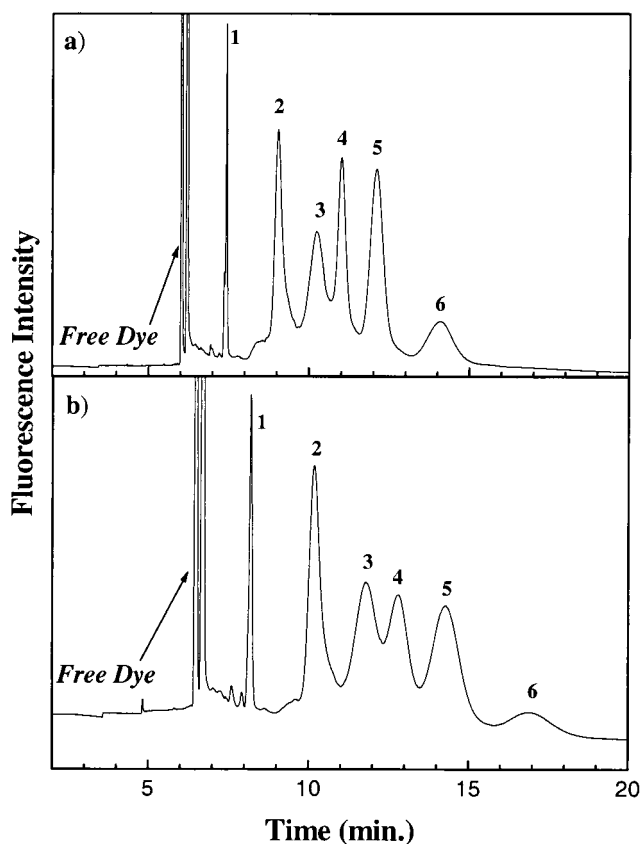

Fig. 2. Electropherograms from capillary-based SDS/CGE on a six-protein mixture with an eCAP-coated capillary (*a*) and an uncoated fused-silica capillary (*b*). Capillary dimensions: 100- $\mu\text{m}$  i.d.  $\times$  20 cm (27 cm in total length). Separation voltage: 8.1 kV. Injection: 4 kV for 30 sec. Peaks: (1) calmodulin (MM = 9 kDa); (2)  $\alpha$ -lactalbumin (MM = 14.4 kDa); (3) pepsinogen (MM = 39 kDa); (4) egg albumin (MM = 45 kDa); (5) BSA (MM = 66 kDa); and (6)  $\beta$ -galactosidase (MM = 116 kDa). Each protein concentration in the mixture was  $\approx 1 \times 10^{-9}$  M to  $10 \times 10^{-9}$  M. Injection: 4 kV for 30 s. (These conditions were optimized.)

yield the singly fluorescein-modified product. The other five proteins were labeled nonspecifically.

All six proteins were well resolved within 15 min with capillary-based SDS/CGE by using Beckman Coulter's eCAP-coated capillary as indicated in Fig. 2*a*. The peak corresponding to singly labeled calmodulin (peak 1 in Fig. 2*a*) is symmetrical and sharp, indicating the high-resolving nature of capillary-based SDS/CGE. The other protein peaks are separated but are much broader, indicating the presence of a heterogeneously labeled protein population caused by nonspecific labeling (see below), the effects of longer migration times for the larger proteins, or a combination of these.

For comparison with the chip-based separation conditions, where uncoated channels are used, the capillary SDS/CGE was performed with an uncoated fused-silica capillary. The proteins were still separated on the uncoated capillary (Fig. 2*b*) but with reduced resolution. Peak broadening was likely caused by nonspecific interactions between proteins and the charged inner surface of the uncoated capillary.

The same protein mixture was then used for chip-based separations. As shown in Fig. 3, a separation voltage of 1 kV resolves all six proteins within 3.5 min. In fact, the pattern of the peaks is quite similar to the capillary separation (Fig. 2*b*), but the time required for the on-chip separation is more than a factor of five shorter. Increasing the voltage from 1 kV to 5 kV increases the speed concomitantly, with the separation

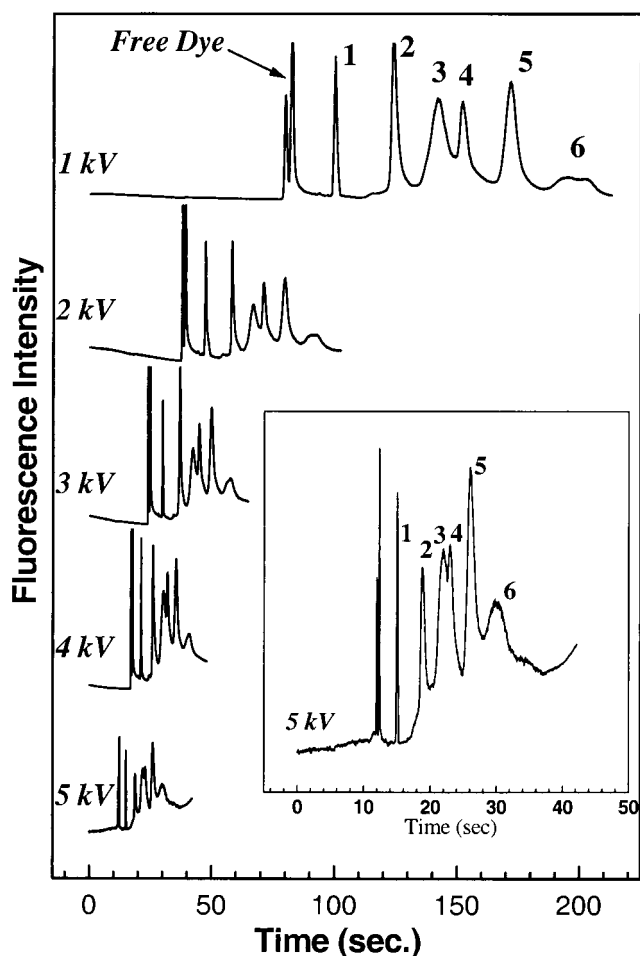

FIG. 3. Electropherograms of protein mixture (Fig. 2) with microchannel-based SDS/CGE with different separation voltages: 1 kV (a), 2 kV (b), 3 kV (c), 4 kV (d), and 5 kV (e).

being complete in less than 35 s at a separation voltage of 5 kV. The increase in separation speed compromised the separation efficiencies, as evidenced by decreases in theoretical plate

numbers and increases in plate heights at higher separation voltages (see Table 1). However, a maximum in time-based separation efficiencies ( $N/s$ ) occurs at intermediate operating voltages.

In the floating-injection approach used here, the sample is migrated across the intersection by applying a voltage between reservoirs 2 and 3 (see Fig. 1), while the other two reservoirs are allowed to float. The effect of migrating the sample across the intersection for different lengths time was investigated. Variations of the migration time from 5 s to 30 s while maintaining a constant injection voltage (200 V) did not appreciably alter either the quality of the separation or the peak intensity (data not shown). These results indicate minimal leakage of the sample into the separation channel during the injection (presumably because of the viscous nature of the gel used in the chip and the slow diffusion of the proteins) and that sufficient time was allowed for all components to migrate to the intersection.

For the coated and uncoated capillaries and the chip, the separation performance for the nonspecifically labeled proteins was quantified for several peaks (see Table 1). Strictly speaking, theoretical plate numbers should be calculated by using a peak from a single component. By their nature, protein samples are heterogeneous. In addition, the nonspecifically labeled proteins have heterogeneity because of variation in the number of attached dyes. As a result, the calculated theoretical plate numbers are a reflection of both the column efficiency and the heterogeneity of a particular sample component. The calculations are intended for comparison of performance between capillaries and for comparison of the column-based separations with the chip-based separations.

For the coated capillary, peak 2 yields a theoretical plate number of  $6.6 \times 10^3$ , which corresponds to a plate height of 30  $\mu\text{m}$ . The separation efficiency decreases in the uncoated capillary, where peak 2 has a theoretical plate number of  $3.5 \times 10^3$  (58- $\mu\text{m}$  plate height). A similar trend is observed for peak 5, where the efficiency decreases from  $3.1 \times 10^3$  theoretical plates (65- $\mu\text{m}$  plate height) in the coated capillary to  $9.7 \times 10^2$  theoretical plates (207- $\mu\text{m}$  plate height) in the uncoated one. For peaks 3 and 4, which correspond to proteins differing in MM by  $\approx 15\%$  (39 kDa and 45 kDa, respectively), a resolution of 1.6 was achieved by using the coated capillary. With the

Table 1. Comparison of capillary-based vs. chip-based SDS/CGE for nonspecifically labeled proteins<sup>a</sup>

		Peak 2			Peak 5			Resolution <sup>b</sup>
		N ( $\times 10^3$ )	H ( $\mu\text{m}$ )	N/s ( $\times 10^2$ )	N ( $\times 10^3$ )	H ( $\mu\text{m}$ )	N/s ( $\times 10^2$ )	
Capillary -Based	eCAP <sup>TM</sup> Coated	6.6 <sup>c</sup>	30 <sup>d</sup>	0.12 <sup>e</sup>	3.1	65	0.043	1.6
	Fused-Silica	3.5	58	0.057	0.97	207	0.011	1.3
On-Chip	1 kV	16	2.8	1.3	6.5	6.9	0.38	1.8
	2 kV	25	1.8	4.2	6.4	7.0	0.80	1.7
	3 kV	19	2.4	5.2	6.5	6.9	1.3	1.4
	4 kV	9.6	4.7	3.7	5.8	7.7	1.6	1.2
	5 kV	4.7	9.6	2.5	3.2	14	1.2	1.1

<sup>a</sup>Calculated from Figs. 2 and 3. All calculations were based on standard equations (27).

<sup>b</sup>For peaks 3 and 4, the resolution was calculated by using the expression  $R = 2 \times (t_3 - t_4) / (\Delta t_{1/2,3} + \Delta t_{1/2,4})$ , where  $t_3$  and  $t_4$  are the migration times of peaks 3 and 4 and  $\Delta t_{1/2,3}$  and  $\Delta t_{1/2,4}$  are the respective full widths at half maximum.

<sup>c</sup>Theoretical plate numbers ( $N$ ) were calculated for peaks 2 and 5. These calculations were based on the measured full width at half maximum ( $\Delta t_{1/2}$ ) of a peak by using the expression  $N = 5.54 \times (t / \Delta t_{1/2})^2$ , where  $t$  is the migration time.

<sup>d</sup>Plate heights (H) are calculated by dividing the column length by the theoretical plate numbers. For CE-based separations, a column length of 20 cm was used. For chip-based separations, a column length of 4.5 cm was used.

<sup>e</sup>Theoretical plates per second ( $N/s$ ) were calculated by dividing theoretical plate numbers ( $N$ ) by migration time.

uncoated fused-silica capillary, however, a decrease in resolution to 1.3 was observed.

For the chip-based separations, the number of theoretical plates was generally better than for the uncoated capillary (Table 1). The efficiency, in terms of plate height, was roughly an order of magnitude better for the chip-based separation than for the capillary. For the time-based efficiency, the performance generally improved with increasing separation voltage. For example, peak 2 has  $5.2 \times 10^2$  theoretical plates per s at 3 kV, corresponding to an electric field of 600 V/cm. For peaks 3 and 4, good resolution was achieved with separation voltages of 1 kV and 2 kV, exceeding the resolution of the coated capillary for these peaks. Even with higher separation voltages (3–5 kV), moderate resolution comparable to that of capillary-based SDS/CGE with the uncoated fused-silica capillary was still maintained.

As indicated in Figs. 2 and 3, specifically labeled calmodulin eluted as a very sharp and symmetric peak in both the capillary-based and chip-based SDS/CGE. In contrast, larger nonspecifically labeled proteins eluted as much broader peaks. Because the reaction conditions for fluorescein-NHS labeling lead to nonspecific labeling of all primary amines in a protein, each labeling reaction likely generates a mixture containing the same protein modified with a variable number of dyes. This likely is a major cause of peak broadening and loss of resolution in our SDS/CGE analyses.

To test the separation performance of the chip-based system with minimized sample-dependant contributions to broadening, mixtures of three single-cysteine-containing proteins were analyzed. Calmodulin, lysozyme, and staphylococcal nuclease 16-cys mutant, labeled either nonspecifically or specifically, were first analyzed by SDS/CGE by using an uncoated fused-silica capillary (Fig. 4*a*). These proteins, which differ by  $\approx 20\%$  in MM, were resolved completely in the specifically labeled mixture (Fig. 4*a*, Bottom). In contrast, the nonspecifically labeled protein mixture produced an electropherogram in which the three protein peaks were resolved poorly and much more broadly (Fig. 4*a*, Bottom), showing the effect of the presence of differently modified proteins on the separation efficiency. Finally, the specifically labeled protein mixture was analyzed with chip-based SDS/CGE at a range of separation voltages (Fig. 4*b*). All three proteins were well resolved under all separation voltages used, with separation being complete in less than 25 s at a separation voltage of 5 kV (Fig. 4*b*, Inset).

The calculated separation performance parameters for the specifically labeled proteins are included in Table 2. The capillary-based separation yield theoretical plate numbers ranging from  $9.4 \times 10^3$  to  $1.8 \times 10^4$ , which correspond to plate heights from 21  $\mu\text{m}$  to 11  $\mu\text{m}$  (Table 2). For the chip-based separations, the plate numbers are again generally higher than for the capillary, and the plate heights are about an order of magnitude smaller. As was true for the nonspecifically labeled proteins, the optimum voltage for the theoretical plate number is between 2 kV and 3 kV (electric field of 400–600 V/cm). In this voltage range, the theoretical plate number varies from  $3.2 \times 10^4$  to  $4.6 \times 10^4$  (1.4- $\mu\text{m}$  to 0.98- $\mu\text{m}$  plate heights). The time-based efficiencies range from  $1.9 \times 10^2$  plates per s to  $4.1 \times 10^2$  plates per s at 1 kV. They increase with driving voltage, reaching a plateau near  $1.2 \times 10^3$  plates per s for peaks 1 and 2. For peak 3, the time-based efficiencies reach a maximum of  $8.6 \times 10^2$  plates per s at 3 kV and then fall to  $4.2 \times 10^2$  plates per s at 5 kV.

We have been able to transfer successfully the capillary-based SDS/CGE for protein separation onto a microchannel-based format. Compared with capillary-based separations, the chip-based SDS/CGE separation of proteins is clearly superior in terms of separation efficiency and speed. We demonstrate that six proteins, ranging from 9 kDa to 116 kDa in MM, can be separated in less than 35 s, while comparable separation efficiencies are maintained. Specifically labeled proteins dif-

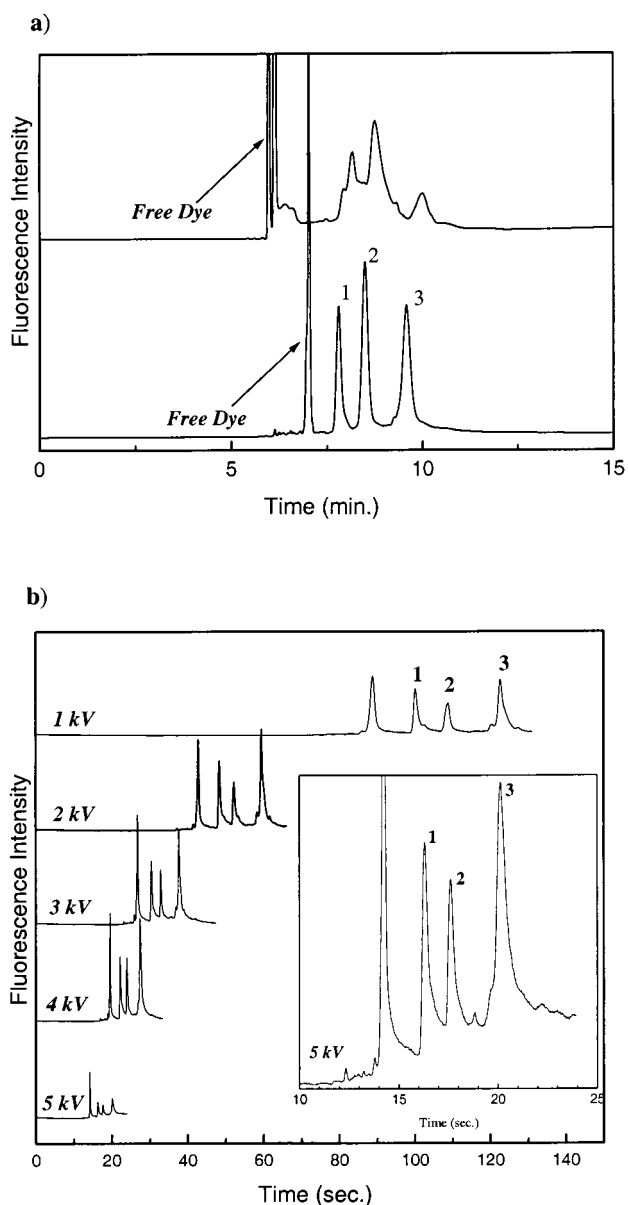

FIG. 4. Electropherograms of three cysteine-containing, fluorescently labeled proteins (peak 1, calmodulin with an apparent MM of 9 kDa; peak 2, lysozyme (hen egg white) with a MM of 14.5 kDa; peak 3, staphylococcal nuclease 16-cys mutant with a MM of 18 kDa). (a) Capillary-based SDS/CGE with the proteins labeled nonspecifically with fluorescein-NHS (Top) or labeled specifically with fluorescein-MAL (Bottom). Capillary: 100- $\mu\text{m}$  i.d.  $\times$  20 cm (27 cm total length) uncoated fused-silica. Separation voltage: 8.1 kV. Injection: 4 kV for 30 s. Note the two different free dyes migrate differently under identical separation conditions. (b) Chip-based SDS/CGE of the specifically labeled proteins with different separation voltages. The Inset highlights the three well resolved protein peaks at a separation voltage of 5 kV. Each protein concentration in the mixture was estimated to be  $\approx 1 \times 10^{-9}$  M to  $10 \times 10^{-9}$  M.

fering in MM by  $\approx 20\%$  can be resolved easily with high resolution in less than 25 s. With chip-based separations, plate heights near 1  $\mu\text{m}$  can be obtained under optimized conditions, which is 10 times better than the capillary-based SDS/CGE. As for time-based efficiency, more than 1,000 plates per s were obtained in chip-based separations, which is more than a 20-fold improvement from the capillary-based separation. Further improvements in chip-based separations can be expected through the use of more sophisticated electronic equipment for fluidic control, increasing the length of the separation

Table 2. Comparison of capillary-based vs. chip-based SDS/CGE for specifically labeled proteins<sup>a</sup>

		Peak 1			Peak 2			Peak 3		
		N ( $\times 10^3$ )	H ( $\mu\text{m}$ )	N/s ( $\times 10^2$ )	N ( $\times 10^3$ )	H ( $\mu\text{m}$ )	N/s ( $\times 10^2$ )	N ( $\times 10^3$ )	H ( $\mu\text{m}$ )	N/s ( $\times 10^2$ )
Capillary-based		18	11	0.38	13	15	0.25	9.4	21	0.16
On-Chip	1 kV	41	1.1	4.1	27	1.7	2.5	23	1.9	1.9
	2 kV	42	1.1	8.6	37	1.2	7.0	46	0.98	7.7
	3 kV	36	1.3	12	39	1.1	12	32	1.4	8.6
	4 kV	25	1.8	11	30	1.5	12	16	2.8	5.8
	5 kV	18	2.4	11	21	2.2	12	8.5	5.3	4.2

<sup>a</sup>Calculated from Fig. 4a (Bottom) and b. See legend in Table 1 for details.

channel, coating the separation channel, optimizing the channel depth, and improving the sample preparation.

Extending the current work, chip-based SDS/CGE could be incorporated into more complex separation schemes. The simplest incorporation would be chip-based SDS/CGE with postcolumn fluorescent labeling. A second area could include chip-based SDS/CGE in an array format where hundreds of channels containing the same or different separation media can be run in parallel on a single glass wafer. A third would be a chip-based two-dimensional SDS/PAGE analog in which tandem separations (for example, isoelectric focusing followed by SDS/CGE) can be integrated into one device. Such methods could potentially provide extremely fast and powerful tools for analyzing complex protein mixtures.

We thank Dave Neyer for helpful discussions and Gary Hux for technical assistance (both from Sandia National Laboratories). Microfabrication was performed at the University of California, Berkeley, Microfabrication Laboratory. S.Y. would like to thank the Cancer Research Institute for a postdoctoral fellowship. W.B.C. would like to acknowledge an Alexander Hollaender Postdoctoral Fellowship sponsored by the Department of Energy and administered by the Oak Ridge Institute for Science and Education. This work was supported in part by the Laboratory Directed Research and Development program of Sandia National Laboratories and by the National Institutes of Health. Sandia is a multiprogram laboratory operated by Sandia Corporation, a Lockheed Martin Company, for the United States Department of Energy under contract DE-AC04-94AL85000.

- James, P. (1997) *Q. Rev. Biophys.* **30**, 279–331.
- Celis, J. E. (1998) *Drug Discovery Today* **3**, 193–195.
- Celis, J. E. & Gromov, P. (1999) *Curr. Opin. Biotechnol.* **10**, 16–21.
- Lopez, M. F. (1999) *J. Chromatogr. B* **722**, 191–202.
- Haynes, P. A., Gygi, S. P., Figeys, D. & Aebersold, R. (1998) *Electrophoresis* **19**, 1862–1871.
- Watzig, H., Degenhardt, M. & Kunkel, A. (1998) *Electrophoresis* **19**, 2695–2752.
- Landers, J. P. (1997) *Handbook of Capillary Electrophoresis* (CRC, Boca Raton, FL), 2nd Ed.
- Weinberger, R. (1993) *Practical Capillary Electrophoresis* (Academic, San Diego).
- Effenhauser, C. S. (1998) in *Microsystem Technology in Chemistry and Life Sciences*, eds. Manz, A. & Becker, H. (Springer, Heidelberg), pp. 51–82.
- Effenhauser, C. S., Bruin, G. J. M. & Paulus, A. (1997) *Electrophoresis* **18**, 2203–2213.
- Van den Berg, A. & Bergveld, P., eds. (1995) *Micro Total Analysis Systems* (Kluwer, Boston).
- Harrison, J. D., Fluri, K., Seiler, K., Fan, Z., Effenhauser, C. S. & Manz, A. (1993) *Science* **261**, 895–897.
- Burns, M. A., Johnson, B. N., Brahmasandra, S. N., Handique, K., Webster, J. R., Krishnan, M., Sammarco, T. S., Man, P. M., Jones, D., Heldsinger, D., Mastrangelo, C. H. & Burke, D. T. (1998) *Science* **282**, 484–487.
- Boone, T. D. & Hooper, H. H., eds. (1998) in *Micro Total Analysis Systems '98* (Kluwer, Boston), pp. 257–260.
- Duffy, D. C., McDonald, J. C., Schueller, O. J. & Whitesides, G. M. (1998) *Anal. Chem.* **70**, 4974–4984.
- Manz, A., Harrison, J. D., Verpoorte, E. & Widmer, M. H. (1993) *Adv. Chromatogr.* **33**, 1–65.
- Simpson, P. C., Roach, D., Woolley, A. T., Thorsen, T., Johnson, R., Sensabaugh, G. F. & Mathies, R. A. (1998) *Proc. Natl. Acad. Sci. USA* **95**, 2256–2261.
- Chiem, N. & Harrison, J. D. (1997) *Anal. Chem.* **69**, 373–378.
- Colyer, C. L., Mangru, S. D. & Harrison, D. J. (1997) *J. Chromatogr. A* **781**, 271–276.
- Hofmann, O., Che, D., Cruickshank, K. A. & Muller, U. R. (1999) *Anal. Chem.* **71**, 678–686.
- Cohen, A. S. & Karger, B. L. (1987) *J. Chromatogr.* **397**, 409–417.
- Guttman, A., Nolan, J. A. & Cooke, N. (1993) *J. Chromatogr.* **632**, 171–175.
- Laemmli, U. K. (1970) *Nature (London)* **227**, 680.
- Shin, I. J., Ting, A. Y. & Schultz, P. G. (1997) *J. Am. Chem. Soc.* **119**, 12667–12668.
- Ocvirk, G., Tang, T. & Harrison, D. J. (1998) *Analyst* **123**, 1429–1434.
- Jacobson, S. C., Hergenroder, R., Koutny, L. B., Warmack, R. J. & Ramsey, J. M. (1994) *Anal. Chem.* **66**, 1107–1113.
- Giddings, J. C. (1991) *Unified Separation Sci.* (Wiley, New York).