

The Avoidance Response in *Phycomyces*

DANIEL LEON JOHNSON and R. IGOR GAMOW

From the Department of Aerospace Engineering Sciences, University of Colorado, Boulder, Colorado 80302

ABSTRACT *Phycomyces* sporangiophores grow away from stationary objects, a phenomenon known as the avoidance response. Evidence is presented suggesting that a growth-stimulating gas is emitted from the sporangiophore and is then swept to the leeward side by air currents resulting in higher gas concentration on that side. The presence of a stationary barrier decreases the passive movement of the gas away from the leeward side. It is proposed that an increase of this gas on one side causes that side to grow faster. Indirect evidence suggests that the gas is water vapor.

INTRODUCTION

The sporangiophores of *Phycomyces* respond to four stimuli: light, gravity, stretch, and closeness of a barrier—they respond in respect to both the intensity and direction of light, they are negatively geotropic, when stretched they respond with an increase in growth opposing the stretch, and they grow away from objects that are closer than 2 or 3 mm. This last response has been called the avoidance response (Bergman et al., 1969; Ortega and Gamow, 1970). Until now, the mechanism by which the sporangiophores communicate with the barrier has been totally unknown, and it is the heart of this report to give a possible answer to this question.

Although we do not know how the sporangiophore “senses” the presence of a barrier, a number of properties of the avoidance response have been established. The avoidance response is initiated by objects independent of their material nature and shape: “glass, wood, plastic, black tape, or a crystal transparent for infrared radiation of a black body at room temperature are equally effective” (Bergman et al., 1969). In addition, if the barrier is placed symmetrically around the sporangiophore, a transitory increase in growth occurs (Ortega and Gamow, 1970). Experimentally, this effect can be achieved either by inserting the sporangiophore into a capillary tube, 2 mm in diameter, or by placing two barriers, one each, on opposite sides of the sporangiophore. This observation suggests that the bending away from a single barrier results from an increase in growth on the side nearer the barrier, not a decrease in growth on the far side.

We have found that the avoidance response is independent of gravity, does

not occur in still air, and needs both the movement of air and a barrier, neither alone is sufficient. Our results suggest that the movement of air causes a defined asymmetry of some gas emitted from the sporangiophore that induces an asymmetry in growth; we believe this gas to be water vapor.

MATERIALS AND METHODS

Sporangiophores of *Phycomyces* were grown in shell vials containing 5% potato dextrose agar (PDA) with 0.5% yeast extract. The shell vials were incubated under diffuse incandescent light in a high humidity room at 22°C. Before each experiment the sporangiophores were dark-adapted in red light for at least 20 min. The experimental sporangiophores were set up in front of an optical comparator (Gamow and Finnoff, 1969) and all measurements of growth and bending were derived from direct tracings on the screen of the comparator. With the comparator, one or more sporangiophores could be measured at certain time intervals by tracing them on the shadow graph with a fine felt tip pen and later transferring the tracings onto paper. This method allows one to simultaneously record a given sporangiophore's length, its diameter at different points along the length, as well as the position of the bend and its radius of curvature. Differential growth measurements were made to provide a comparable parameter between *Phycomyces* differing in both their basal growth rates and growing zone diameters. We have defined differential growth as the growth difference between the two sides of a sporangiophore over a specific period of time; 15 min was our standard unit of time. Then, consider a sporangiophore of diameter d measured 1 mm below the sporangium, that has bent α degrees in 15 min. Simple geometry shows that the difference in growth between the fastest and the slowest growing side in a given unit of time is $\frac{2\pi\alpha d}{360}$ (see Appendix for details) which we have called s . The per cent of differential growth is $\frac{100s}{a}$ (where a is the distance the faster growing side has grown in Δt). This method assumes that the diameter of the growing zone remains constant and that the radius of curvature remains smooth.

RESULTS

The Influence of Gravity on the Avoidance Response In order to determine whether the avoidance response would occur regardless of the sporangiophore's orientation with respect to gravity, we measured the avoidance response of sporangiophores in different positions with respect to gravity. The barrier was placed 1 mm away from the sporangiophore. No significant difference in the avoidance response was observed with the sporangiophore upright or upside down. When the barrier was placed horizontally and the sporangiophore was also horizontal either above or below it, avoidance away from the barrier occurred in both cases. When other random orientations were tried, the response was always the same, away from the barrier.

The Decrease of the Avoidance Response in Still Air *Phycomyces* sporangio-

phores when growing under conditions that minimize air currents (in a glass house) show little or no avoidance response. For example, sporangiophores growing in a sealed $1 \times 1 \times 3$ inch glass house with a vertical glass barrier 0.4 mm away showed a 0.57% differential growth with a standard deviation, σ , of 0.70%. In the presence of normal laboratory air movement, the range of the per cent of differential growth was at least one order of magnitude higher. We also found that a sporangiophore in still air showing little or no avoidance response, initiated a normal response after the glass house was continually moved back and forth. This effect occurred presumably because of the air currents set up in the house. In general, internal air currents created in a number of different ways in the glass house were equally effective.

The Necessary and Sufficient Conditions for the Avoidance Response We have shown that the avoidance response is greatly decreased when normal laboratory air movements around the sporangiophore are eliminated. With the experimental chamber shown in Fig. 1, we have obtained data showing that the avoidance response occurs if and only if there exist both air movements and a barrier. A sporangiophore growing next to a glass barrier placed 0.4 mm away does show a strong avoidance response when a wind of about $200 \mu/\text{sec}$ is blown towards the sporangiophore and normal to the barrier. The air jet is produced by displacing a known amount of water in a filtering flask through a burette. At these low wind velocities, the air flow is laminar. The $200 \mu/\text{sec}$ wind was calculated by measuring both the amount of air being displaced by water and the total area of the entrance jets. By increasing the displacement of air by a factor of 25 larger than needed for our calculated $200 \mu/\text{sec}$ wind, we have measured a wind velocity of $5000 \mu/\text{sec}$ by means of a thermistor. At our calculated $200 \mu/\text{sec}$ wind, we do record a signal when the jet is turned on, but the electrical readout is so nonlinear in this region that we can only say the velocities are between 200 and $1000 \mu/\text{sec}$. Velocities of smoke moving in our apparatus are about the same order of magnitude. Fig. 2 is a direct tracing from the screen of the comparator. Fig. 3 represents a plot of the data from

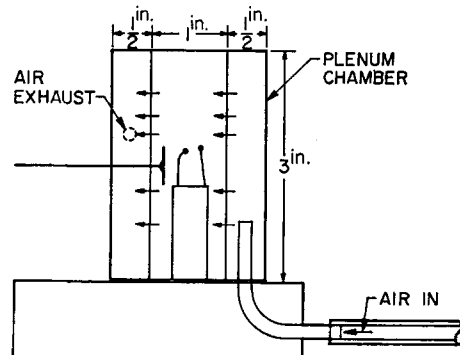

FIGURE 1. A sketch of the chamber used to measure the effect of a barrier with and without wind.

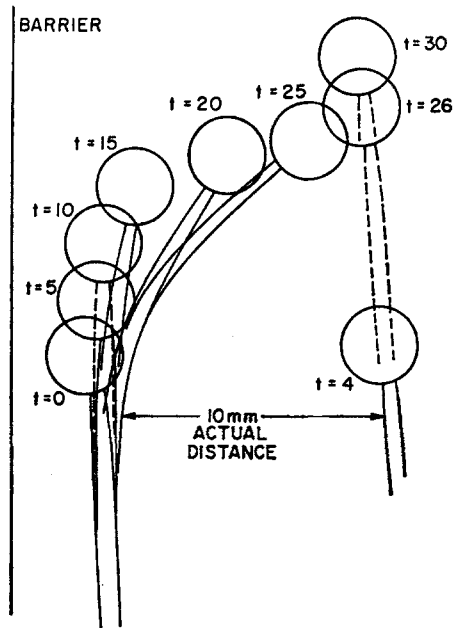

FIGURE 2. A direct tracing from the screen of the comparator. The separation of the sporangiophores is not drawn to scale in order to place them in a single figure: t refers to the time in minutes that each position was sketched.

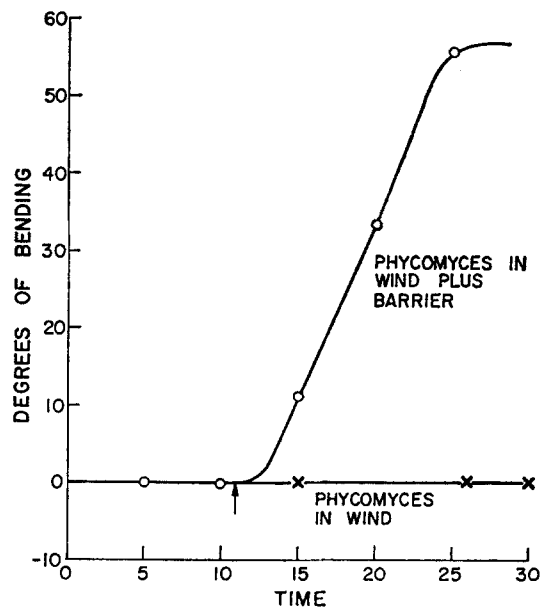

FIGURE 3. A plot of the data from Fig. 2. The arrow represents the time the wind was turned on.

Fig. 2. The results of the experiment clearly show that the sporangiophore next to the barrier and in the wind avoids the barrier; whereas, the sporangiophore some distance away even though still in the wind does not bend. The per cent of differential growth of the sporangiophore in the wind and next to

the barrier was found to be 6.1% with a standard deviation of 3.8%. No significant per cent of differential growth could be measured with the sporangiophore in the wind but not in front of the barrier. Thus the movement of air and the presence of a barrier are both the necessary and sufficient conditions

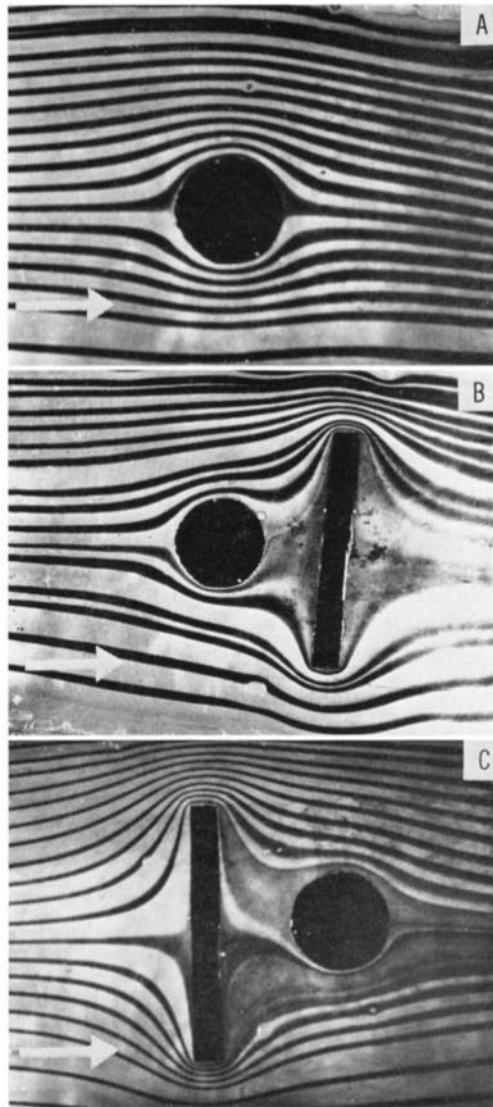

FIGURE 4. A photograph of laminar flow in a Hele-Shaw apparatus representing a cross-section of a sporangiophore in front of a barrier. Although based on different physical principles, the flow lines one would observe using moisture and air instead of water and ink would be very similar. Arrows represent direction of flow.

for the avoidance. We also found that an avoidance response is initiated when the wind is blown towards the barrier opposite the side of the location of the sporangiophore. The results of these experiments suggest that the movement of air is causing a higher concentration of some emitted gas to occur in the

region between the barrier and the growing zone of the *Phycomyces*. In the Discussion, we argue in favor of water vapor being the gas.

Analysis of Laminar Flow in a Model System. We now know that a laminar flow directed towards a sporangiophore in front of a barrier causes the sporangiophore to initiate the avoidance response. With the use of a Hele-Shaw table,¹ we can visualize the flow lines around a circular object in front of a barrier. It becomes immediately clear that the region in back of the sporangiophore is a region of stagnation, and it is also clear that any substance released from the sporangiophore would be swept around and concentrated in the region immediately behind the sporangiophore and in front of the barrier. We have followed the movement of color dye placed on the windward side of an idealized sporangiophore, seeing it carried around and concentrated on the leeward side. Fig. 4 A is a photograph of the Hele-Shaw table with a circular disc representing the cross-section of a sporangiophore. Fig. 4 B is a representation of a sporangiophore with a barrier behind it; i.e., the flow first towards the sporangiophore, then towards the barrier. Fig. 4 C is the same but the flow is in the opposite direction; i.e., from behind the barrier towards the sporangiophore.

DISCUSSION

In the *Phycomyces* review article, the section on avoidance begins "the least understood of the sensory properties of *Phycomyces* is the avoidance response." By now a rather large catalogue of facts about the avoidance response exists, and an explanation of the phenomenon now seems possible. The pertinent information about the avoidance response is listed below.

1. Thimann and Gruen (1950) have reported that a small water drop placed on one side of the growing zone results in an increase in growth rate on that side.
2. Walter (1921) reported that *Phycomyces* sporangiophores placed between a wet and a dry wall tended to bend towards the dry wall.
3. Ortega and Gamow (1970) reported that the enclosure of a sporangiophore between two closely spaced cover slips or the insertion of the sporangiophore into a narrow capillary tube initiates a growth response.

We are now reporting two additional phenomena:

4. Avoidance responses occur independently of gravity.
5. A decrease in the avoidance response occurs in the absence of normal air currents.

¹ The Hele-Shaw apparatus used consists of the slow flow of a liquid between two flat plates. The distance between the two plates was 0.01 inch and any object placed between the plates was also 0.01 inch thick. Dye crystals are used to mark a pattern of flow about the objects. The small distance between the plates reduces the inertial forces with respect to the viscous forces. This results in a reduced Reynolds number that matches the Reynolds number of a slow flow around a sporangiophore. Hence, the flow pattern will also be similar.

Of the several possible models that could be proposed to explain the mechanism of the avoidance, natural convection is an obvious one. Since we have found that the avoidance response is independent of the direction of gravity, this eliminates all models based on natural convection—either mass convection or heat convection.

The second phenomenon which we found—the decrease in the avoidance response in relatively still air—appears to provide the main clue in the avoidance response riddle. In still air a gas lost from the *Phycomyces* diffuses away from the sporangiophore forming a symmetrical gradient. In randomly moving air this gradient also randomly changes position. With randomly moving air and in the presence of a barrier, there will be less movement of air between the sporangiophore and the barrier because of simple shielding. As shown in Figs. 4 B and 4 C, this is also true when the flow is either toward the front of the barrier or behind it. Air currents around the front side of the sporangiophore would not be decreased and would tend to sweep any substance secreted from the sporangiophore from the windward side to the leeward side. The effect of this asymmetric wind movement can be visualized by use of the Hele-Shaw flow table. Fig. 4 shows that the movement of flow on the leeward side is relatively stagnant; with this system we have shown that color dye placed on the windward side is carried around and collected on the leeward side. It therefore appears both necessary and sufficient to have both the moving air and a barrier in order to initiate an avoidance response. The Hele-Shaw flow table represents the physical situation of what happens when a small barrier is placed close to the sporangiophore. The avoidance response with large barriers placed 2 or even 3 mm away can be explained by the fact that the large barrier is shielding the sporangiophore from wind in one direction. Because of this more air currents will be moving in the direction of the sporangiophore, again sweeping the gas towards the leeward side.

The Nature of the Stimulating Gas Although the experiments presented in this report do not bear directly on the nature of this gas, we believe a good argument can be made for the gas being water vapor. The experiments of both Thimann and Gruen (1960) and Walter (1921) imply that the regions of the sporangiophore in higher humidity will grow faster than regions in lower humidity.

Ortega and Gamow (1970) have reported that a transitory growth response occurs when a sporangiophore is inserted into a capillary. Since it is known (Bergman et al., 1969) that the stage IV sporangiophore transpires at a rate of 1.2 nliters/min, one can easily calculate how long it would take for the humidity to rise to 100% in the capillary. We have calculated² that the hu-

² At 22°C a 100% humidity contains 2.4×10^{-6} g of water/cc dry air. Therefore, a capillary 2 mm in diameter and 1.25 cm long (volume = 0.04 cm^3) will be able to hold about 1×10^{-6} g of water. Transpiration rate has been measured by Foster (Bergman et al., 1969) to be about 1 nliter/min which is 1×10^{-6} g of water/min.

midity would rise to this value within 1 min. This may explain the finding (Ortega and Gamow) that the avoidance growth response from a double barrier is faster than the avoidance response from a single barrier. In general, it is well-known that *Phycomyces* grow better at higher humidities; it is thus not surprising to observe an increase in localized growth when and wherever the humidity around the sporangiophore is increased.

This scheme also explains our finding that the avoidance response is independent of gravity. In addition, the observation made by Dennison (Bergman et al., 1969) that *Phycomyces* tend to grow to windward and explained by him as a stretching response may again be due in part to the sweeping of the gas towards the leeward side.

If water vapor is indeed the gas, then the avoidance response is explained by the presence of humidity receptors. In this connection, it is significant that the avoidance response does not occur when the sporangiophore is growing under water (Delbrück, personal communication).

If the gas is water, a definitive answer to this question could be obtained by conducting the wind-blowing experiments with the humidity at each point in the box exactly known. Unfortunately, the determination of absolute humidity in a dynamic situation is technically very difficult. It is interesting to note that transpiration occurs even at 100% relative humidity (Bergman et al., 1969).

APPENDIX

Consider the circular bend in a sporangiophore as follows:

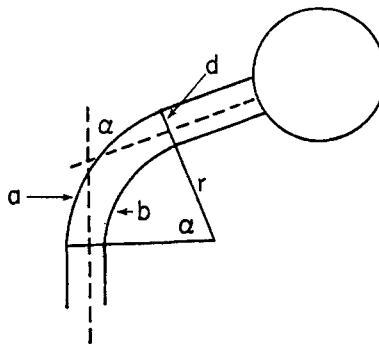

The difference in distance between the outer arc (a) and the inner arc (b) is

$$a - b = \frac{2\pi(r + d)\alpha}{360} - \frac{2\pi(r)\alpha}{360} = \frac{2\pi\alpha d}{360}$$

The values of a and α are measured directly from the tracing of the sporangiophore on

the optical comparator. We thus define per cent differential growth to be

$$\frac{(100) \frac{(2\pi ad)}{360}}{a}$$

We wish to thank Miss Bärbel Böttger for her excellent technical assistance.

We wish to thank Bob Cohen and Max Delbrück for reading and criticizing the original manuscript, and Bob Longfellow, who initiated some of the original experiments as an undergraduate research project.

Received for publication 12 June 1970.

REFERENCES

- BERGMAN, K., P. BURKE, E. CERDÁ-OLMEDO, C. N. DAVID, M. DELBRÜCK, K. W. FOSTER, E. W. GOODELL, M. HEISENBERG, G. MEISSNER, M. ZALOKAR, D. S. DENNISON, and W. SHROPSHIRE, JR. 1969. *Phycomyces*. *Bacteriol. Rev.* 33:99.
- GAMOW, R. I., and C. FINNOFF. The study of a photoresponse by means of microbeam laser stimulation. *Proc. 6th Annu. Rocky Mountain Bioengineering Symp.* May 5-6, 1969. 82-84.
- ORTEGA, J. K. E., and R. I. GAMOW. 1970. *Phycomyces*: Evidence for habituation of the light growth response. *Science (Washington)*. 168:1374.
- THIMANN, K. V., and H. E. GRUEN. 1960. The growth and curvature of *Phycomyces* sporangio-phores. *Beih. Z. Schweiz. Forstv.* 30:237.
- WALTER, H. 1921. Wachstumsschwankungen und hydrotropische Krümmungen bei *Phycomyces nitens*. *Z. Bot.* 13:673.