

Effects of Ouabain on Fluid Transport and Electrical Properties of *Necturus* Gallbladder

Evidence in Favor of a Neutral Basolateral Sodium Transport Mechanism

LUIS REUSS, ELSA BELLO-REUSS, and TIMOTHY P. GRADY

From the Departments of Physiology and Biophysics, and Medicine, Washington University School of Medicine, and The Jewish Hospital of St. Louis, St. Louis, Missouri 63110

ABSTRACT Net fluid transport (J_v) and electrical properties of the cell membranes and paracellular pathway of *Necturus* gallbladder epithelium were studied before and after the addition of ouabain (10^{-4} M) to the serosal bathing medium. The glycoside inhibited J_v by 70% in 15 min and by 100% in 30 min. In contrast, the potentials across both cell membranes did not decrease significantly until 20 min of exposure to ouabain. At 30 min, the basolateral membrane potential (V_{cs}) fell only by ca 7 mV. If basolateral Na transport were electrogenic, with a coupling ratio (Na:K) of 3:2, the reductions of V_{cs} at 15 and 30 min should be 12–15 and 17–21 mV, respectively. Thus, we conclude that the mechanism of Na transport from the cells to the serosal bathing solution is not electrogenic under normal transport conditions. The slow depolarization observed in ouabain is caused by a fall of intracellular K concentration, and by a decrease in basolateral cell membrane K permeability. Prolonged exposure to ouabain results also in an increase in paracellular K selectivity, with no change of P_{Na}/P_{Cl} .

INTRODUCTION

Salt transport across gallbladder epithelium requires the presence of an active Na extrusion mechanism at the basolateral membrane of the cells, because Na is transported against an electrochemical potential > 100 mV (Reuss, 1979). On the basis of the magnitude and/or metabolic dependence of the transepithelial electrical potential in gallbladders of several species, Rose (1978) has proposed that the Na pump is electrogenic, i.e., that its operation results in current flow across the membrane. To test this hypothesis, we have studied the effects of the cardiac glycoside ouabain on spontaneous fluid transport (J_v) and on the electrical properties of *Necturus* gallbladder. The simple geometry and relatively large size of the epithelial cells of this tissue allow one to perform circuit analysis

from which the equivalent electromotive forces (emfs) of the membranes can be calculated (Reuss and Finn, 1975 *a, b*). The present work consisted of: first, comparing the time-course of the effects of ouabain on J_v and the cell membrane potential, and second, establishing the mechanisms by which the slow cell depolarization observed in ouabain takes place. Our results do not support the hypothesis of an electrogenic Na transport mechanism and demonstrate that cell depolarization results from a reduction of basolateral membrane K permeability and a drop in intracellular K concentration.

MATERIALS AND METHODS

Necturi (*Necturus maculosus*) were obtained from Mogul-Ed Co. (Oshkosh, Wis.), kept at 4–8°C in the dark, and fed with live goldfish. The animals were anesthetized with 2% tricaine methane sulfonate (Sigma Chemical Co., St. Louis, Mo.), and gallbladders were removed and mounted as previously described (Reuss and Finn, 1975 *a*, 1977 *a*).

Bathing Solutions

Standard Ringer solution had the following composition (mM): NaCl 109.2, KCl 2.5, CaCl₂ 1.0, NaHCO₃ 2.4, glucose 10. The solution was equilibrated with room air and had a pH of about 8.0. All ion replacements were isomolar. Dilution potentials were measured by exposing the tissue to a mucosal solution in which NaCl concentration was reduced to half and sucrose was added to keep the osmolality constant. Ouabain (Sigma Chemical Co.) was added to the serosal side to a final concentration of 10⁻⁴ M. In all experiments, the mucosal and serosal solutions were replaced continuously.

Electrical Measurements

Potentials and resistances were in general measured as previously described (Reuss and Finn, 1975 *a*, 1977 *a*). Borosilicate glass capillaries with filament (W-P Instruments, Inc., New Haven, Conn.) were used to prepare the intracellular microelectrodes. Only electrodes with a tip resistance larger than 15 MΩ were used. Extracellular electrodes were Ag-AgCl pellets, or calomel electrodes, connected to the bathing media by 3.5% agar-Ringer bridges. All potentials measured in the presence of asymmetric bathing media were corrected for the corresponding liquid junction potentials, as previously described (Reuss, 1978).

In most experiments, impalements were performed from the mucosal side, at an angle of about 40–60°, by means of remote control motorized micromanipulators (Stoelting Co., Chicago, Ill.). In a few experiments, the ionic selectivity of the basolateral membrane was studied. To reduce the thickness of the serosal unstirred layer, the tissues were mounted serosal side up, the subepithelial tissue was partly removed by dissection, and impalements were performed across the basolateral membrane. Cell membrane potentials and ratio of membrane resistances did not differ from the values obtained with impalements from the mucosal side.

Transepithelial current pulses (usually 50 μA × cm⁻² and 1-s duration) were provided by the constant current output of a stimulus isolation unit driven by an Anapulse stimulator (W-P Instruments, Inc.). Intracellular current pulses (0.5–2 × 10⁻⁸ A, 1-s duration) were passed through a high output resistance electrometer. The current was monitored. Electrical potentials (transepithelial: V_{ms} , apical membrane: V_{mc} , and basolateral membrane: V_{cs}) were measured with high input impedance electrometers, provided

with digital readouts to 0.1 mV, amplified, displayed in a storage oscilloscope (Tektronix, Inc., Beaverton, Oreg.), and recorded in a three-channel strip chart recorder (Gould, Inc., Cleveland, Ohio).

30 min after mounting the tissue in the chamber, a 1:2 NaCl dilution potential was measured, as previously described (Reuss and Finn, 1977 *a*). The gallbladder was rejected if its value was < 10 mV.

Under control conditions, the following measurements were performed (see Fig. 1): (a) transepithelial and cell membrane potentials (in at least six cells), (b) transepithelial resistance (R_t , from ΔV_{ms} upon transepithelial current passage), (c) ratio of cell membrane resistances (R_a/R_b , from $\Delta V_{mc}/\Delta V_{cs}$ upon transepithelial current passage); R_t and R_a/R_b

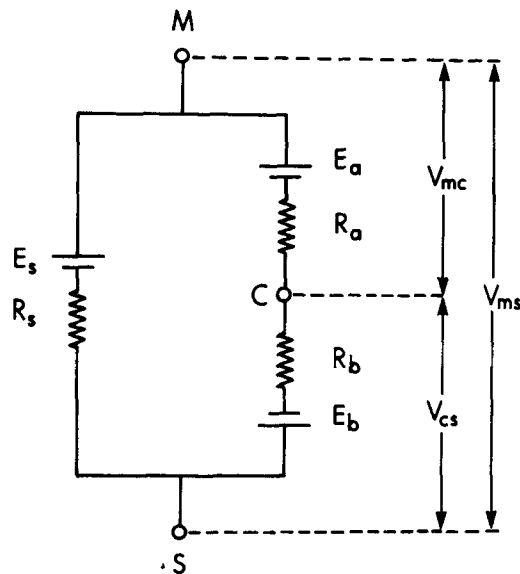

FIGURE 1. Electrical equivalent circuit for *Necturus* gallbladder epithelium. M, C, and S represent the mucosal bathing medium, the cell, and the serosal bathing medium, respectively. Each element of the circuit is represented by a Thévenin electrical equivalent, i.e., an electromotive force (E) in series with a resistance (R). The subscripts a , b , and s refer to the apical cell membrane, the basolateral cell membrane, and the paracellular (shunt) pathway, respectively. The symbols V_{mc} , V_{cs} , and V_{ms} refer to the apical membrane, basolateral membrane, and transepithelial potential, respectively.

were corrected for the voltage drops in the bathing solutions, (d) intraepithelial cable analysis (Eisenberg and Johnson, 1970; Frömter, 1972; Reuss and Finn, 1975 *a*), to calculate R_z , the equivalent resistance to R_a and R_b in parallel ($R_z^{-1} = R_a^{-1} + R_b^{-1}$),¹ (e) effects of mucosal or serosal solution substitutions on V_{ms} , V_{mc} , V_{cs} , R_t , and R_a/R_b (a microelectrode was kept in a cell and one of the bathing media was replaced; only fully reversible results of ion substitutions were accepted). From these data, the emfs of the

¹ In all experiments, hyperpolarizing current pulses of $1-2 \times 10^{-8}$ A and 1-s duration were employed. Depolarizing pulses occasionally result in apparent increases of intercellular coupling resistance.

cell membranes and the shunt were calculated (in Na-Ringer and in the experimental solution) as previously described (Reuss and Finn, 1975 *a, b*). After exposure to ouabain, measurements like the ones described above were obtained continuously from the same cell, or at intervals in several cells.

Fluid Transport Measurements

Net mucosa-to-serosa fluid transport was measured by the horizontal capillary method (Diamond, 1962 *b*), at 5-min intervals, in gallbladders removed from animals of the same batches used for the electrophysiological experiments.

Intracellular Ionic Concentrations

Intracellular Na and K concentrations were measured by atomic absorption in scraped epithelial cells prepared as described by Cremaschi and Hénin (1975). ^{14}C -Inulin was used as extracellular marker.

Unless otherwise indicated, results are expressed as means \pm SE, and statistical comparisons are based on analyses of paired data.

RESULTS

The control properties of the tissues differed somewhat from those previously reported by us (Reuss and Finn, 1975 *a, b*; 1977 *a, b*; Reuss, 1978) and others (Frömter, 1972; Van Os and Slegers, 1975). As stated by Suzuki and Frömter (1977), these differences could be caused by a better oxygen supply to the epithelium when the mucosal solution is replaced continuously. The main differences observed were a smaller transepithelial resistance and a larger value of R_a/R_b . The cell potentials, however, did not differ from our recent measurements (e.g., Reuss and Finn, 1977 *a, b*; Reuss, 1978) and are consistently higher than those found by Suzuki and Frömter (1977) and Graf and Giebisch (personal communication). The reason for this difference is not apparent.

Our observations of the time-course of the impalement and the effect of repeated advance of the microelectrode do not support the contention of Zeuthen (1977, 1978) that there is a significant intracellular potential gradient. With high resistance microelectrodes and proper support of the tissue, the change in potential recorded upon impalement is immediate. Further advances usually do not result in changes of the measured potential until the basolateral membrane is penetrated. Occasionally, changes of the order of 2–3 mV, in either direction, are observed (see Suzuki and Frömter, 1977).

Effects of Ouabain on Spontaneous Fluid Transport (J_v)

Mean control fluid transport was ($12.1 \pm 2.3 \mu\text{l} \times \text{cm}^{-2} \cdot \text{h}^{-1}$) in good agreement with the results of Hill quoted by Zeuthen (1977) and the results of Van Os quoted by Suzuki and Frömter (1977). Ouabain (10^{-4} M, serosal medium) irreversibly inhibited J_v by about 70% in 15 min and completely in 30 min (Fig. 2). The time-course of the inhibition produced by ouabain was somewhat variable. In five out of the six experiments summarized in Fig. 2 a decrease of at least 18% was observed in the initial 5-min period after exposure to the glycoside.

From the mean control value of J_v , assuming that Na is transported at the same concentration as present in the mucosal medium (Hill and Hill, 1978), the

net Na flux ($J_{\text{Na}}^{\text{net}}$) can be calculated to be $0.38 \text{ nmol} \times \text{cm}^{-2} \cdot \text{s}^{-1}$, or $38 \mu\text{A} \times \text{cm}^{-2}$. At 15 min, $J_{\text{Na}}^{\text{net}}$ is reduced to 29% of control, and at 30 min to zero. These values will be employed later to test the hypothesis of electrogenic Na transport at the basolateral membrane.

Effects of Ouabain on Transepithelial and Cell Membrane Potentials

In contrast with the rapid effect of ouabain on J_v , the cellular potential changed very slowly after addition of the glycoside. The time-course of the basolateral potential, in seven tissues in which the microelectrode could be maintained in a cell for at least 30 min, is shown in Fig. 3. Note that cell depolarization becomes statistically significant only after 20 min. At 30 min, V_{cs} was reduced by 6.6 ± 1.0 mV. The long-term effect of ouabain on potentials is summarized in Table I. Both cell membranes depolarized progressively, for at least 3 h. The transepi-

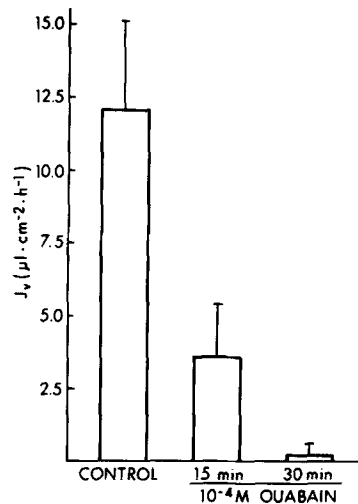

FIGURE 2. Effect of ouabain on net fluid transport (J_v). Abscissa indicates the time of exposure to the drug. $n = 6$ experiments.

thelial potential also fell. A significant change was demonstrable at 30 min. V_{ms} was not different from zero at 90 min of exposure to ouabain. In appropriate control experiments it was shown that these potential changes are not the result of changes in the properties of the tissue because of prolonged in vitro incubation.

Effects of Ouabain on Electrical Resistances

Ouabain produces a small, but significant, increase in transepithelial resistance, and a large reduction in the ratio of membrane resistances. Both changes are significant after 30 min. To establish the individual resistance change(s) involved in these effects, cable analysis was performed in several tissues before, and at several intervals after the administration of the drug. The results obtained in the period from 30 to 60 min are summarized in Table II. At this time, the current spread within the epithelium was radially symmetric, as under control

conditions. Two changes are evident: first, a twofold increase of basolateral membrane resistance, and second, a moderate increase in shunt resistance. Cable analysis attempts at longer periods after ouabain were most of the time unsuccessful because of uncoupling of the epithelial cells, as demonstrated by large decreases of the space constant for intraepithelial current spread. This

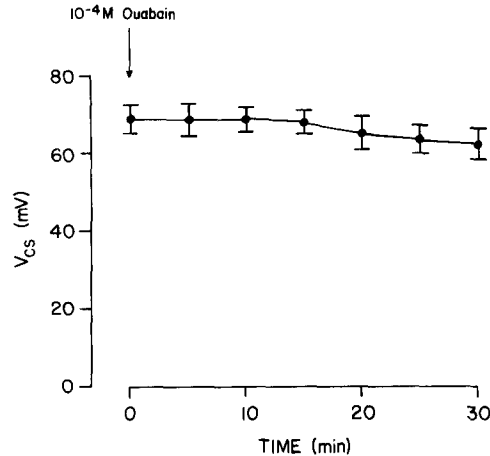

FIGURE 3. Effect of ouabain on basolateral membrane potential (V_{cs}). Records were obtained continuously from a single cell in each of seven preparations.

TABLE I
EFFECTS OF OUABAIN ON
TRANSEPITHELIAL AND CELL MEMBRANE POTENTIALS

	V_{ms}	V_{mc}	V_{cs}
Control	1.1 ± 0.1	65.7 ± 1.8	66.7 ± 1.8
Ouabain, 60 min	0.4 ± 0.1	50.0 ± 3.1	50.4 ± 3.1
Δ	0.6 ± 0.1	15.7 ± 2.9	16.3 ± 3.0
P	<0.001	<0.001	<0.001
Control	1.0 ± 0.1	64.1 ± 1.4	65.1 ± 1.4
Ouabain, 120 min	0.1 ± 0.1	42.4 ± 2.1	42.5 ± 2.1
Δ	0.9 ± 0.1	21.7 ± 2.2	22.6 ± 2.2
P	<0.001	<0.001	<0.001
Control	0.8 ± 0.2	64.8 ± 2.3	65.6 ± 2.2
Ouabain, 180 min	0 ± 0.1	34.7 ± 6.3	34.7 ± 6.3
Δ	0.8 ± 0.2	30.1 ± 6.5	31.0 ± 6.4
P	<0.005	<0.005	<0.005

Values in millivolts. $n=19$ gallbladders (60 and 120 min), $n=8$ gallbladders (180 min). Tissues bathed with Na-Ringer on both sides. Each value for a given tissue is the mean of at least five impalements.

effect can be due to cell depolarization (Lewis et al., 1976), possibly because of an increase of intracellular free calcium concentration (Loewenstein et al., 1967). Resistance values after ca 60 min of exposure to ouabain are, therefore, uncertain. In experiments in which more prolonged observations were carried on after ouabain addition, R_a/R_b increased toward the value observed before

ouabain. This could result from a secondary rise of R_a or a late fall of R_b . The available data do not allow us to distinguish between these possibilities.

Effects of Ouabain on Cell Membrane emfs

Cell membrane emfs were calculated from the measured potentials and resistances before and 30–60 min after addition of ouabain, assuming that the shunt emf (E_s) is zero during bilateral exposure to Na-Ringer (in the presence or absence of ouabain). The results are summarized in Table III. Both cell membrane emfs fall. The effect on E_b is ca five times larger than the effect on E_a . This difference accounts for the transepithelial potential drop. Because $V_{ms} = (E_b - E_a) R_s / (R_a + R_b + R_s)$, a larger fall of E_b relative to E_a causes a decrease

TABLE II
EFFECTS OF OUABAIN ON RESISTANCES

	R_t	a	R_a	R_b	R_s
Control	220±50	2.46±0.17	5,590±260	2,320±250	230±20
Ouabain	250±20	1.33±0.12	5,620±540	4,240±160	260±20
Δ	30±10	1.14±0.21	-30±600	1,930±90	30±10
P	<0.025	<0.001	NS	<0.01	<0.025

Values in ohms×square centimeter. R_a , R_b , and R_s calculated from R_t and a in each tissue, and from the mean value of R_z of seven gallbladders. Cable analysis performed before and between 30 and 60 min of exposure to ouabain. $n=12$ tissues (see text).

TABLE III
EFFECTS OF OUABAIN ON CELL MEMBRANE EQUIVALENT ELECTROMOTIVE FORCES

	E_a	E_b
Control	42.4±3.7	74.9±2.5
Ouabain	37.2±4.2	49.3±3.6
Δ	5.2±2.2	25.6±4.3
P	<0.05	<0.001

Values in millivolts. $n=12$ experiments (the same as in Table II). E_a and E_b calculated as explained in Methods.

of V_{ms} . Arguments to be detailed in the Discussion indicate that the decrease of E_b cannot be explained solely on the basis of a reduction of intracellular K activity.

Effects of Ouabain on Cell Membrane K Selectivity

Relative K conductance across each cell membrane was estimated from the effects of K-for-Na substitutions, in the corresponding bathing medium, on potentials and resistances. These changes were performed several times under control conditions and at intervals after the addition of ouabain to the serosal solution. The time-course of the effects of mucosal K-for-Na substitution on V_{ms} , V_{mc} , and V_{cs} (ΔV_{ms} , ΔV_{mc} , and ΔV_{cs} , respectively) is summarized in Table IV. Note that ΔV_{ms} rises, whereas ΔV_{mc} and ΔV_{cs} decrease with time of exposure

to ouabain. ΔV_{mc} , however, is significantly different from control only after 3 h of the addition of the drug. The progressive rise of ΔV_{ms} is mainly caused by an increased K permselectivity of the shunt pathway (to be discussed in more detail below). The resulting K-Na bionic potential causes a mucosa-negative change of E_s , which increases ΔV_{ms} when the tissue is bathed with K-Ringer, and in addition tends to make ΔV_{mc} larger and ΔV_{cs} smaller than expected from E_a changes alone. The changes of cell membrane emfs produced by exposure to K-Ringer under control conditions and 60 min after addition of ouabain were estimated from the potentials and resistances, assuming that shortly after the substitution the properties of the basolateral membrane remain unchanged. The mean R_z values under control conditions and in the period 30–60 min after ouabain were employed to calculate the resistances of all tissues (see Methods).

TABLE IV
EFFECTS OF MUCOSAL SUBSTITUTION WITH K-RINGER ON
TRANSEPITHELIAL AND CELL MEMBRANE POTENTIALS
BEFORE AND AFTER ADDITION OF OUABAIN

	30 min (n = 7)	60 min (n = 10)	120 min (n = 12)	180 min (n = 5)
ΔV_{ms}				
Control	2.1±0.8	2.8±0.8	2.7±0.7	2.0±0.6
Ouabain	3.7±1.3	6.7±1.1	10.3±1.3	8.5±1.7
P	<0.05	<0.005	<0.001	<0.025
ΔV_{mc}				
Control	52.4±1.6	50.5±1.9	50.5±1.1	57.3±2.1
Ouabain	55.7±1.4	51.3±3.3	52.3±2.6	45.8±0.9
P	NS	NS	NS	<0.01
ΔV_{cs}				
Control	50.3±2.1	47.7±2.2	47.8±1.3	49.3±2.5
Ouabain	52.0±2.3	44.6±3.9	42.0±2.2	37.3±1.1
P	NS	NS	NS	<0.01

Δs are the changes of potentials produced by mucosal substitution of K-Ringer for Na-Ringer. Values in millivolts, before (control) and after serosal addition of the glycoside (ouabain) for the time indicated in the column headings. Different cells were impaled (in the same tissues) before and after ouabain.

The changes of E_a produced by exposure to K-Ringer were 63.8 ± 5.2 mV before ouabain and 67.1 ± 6.4 mV after 1 h of exposure to the glycoside. These values do not differ significantly. In sum, ouabain does not produce measurable changes of apical membrane K selectivity until about 3 h after its addition to the serosal bathing medium.

The results obtained from K-for-Na substitutions in the serosal solution are presented in Table V. In contrast with the mucosal substitution experiments, there is a sizable reduction of basolateral membrane K selectivity within 30 min of the action of ouabain. This result could be predicted from the observed increase of basolateral membrane resistance: inasmuch as the K transference number (T_K) under control conditions is about 0.9 (Reuss, 1979), a decrease of K conductance (g_K) is necessary to account for a twofold increase of R_b . The

changes of E_b produced by exposure to K-Ringer on the serosal side were calculated under the assumption that the values of R_a and E_a remained unchanged. In the control condition, ΔE_b was 80.8 ± 7.0 mV. 60 min after ouabain, it had decreased to 65.0 ± 6.1 mV ($P < 0.01$). Although there are several possible sources of error in these calculations, the result agrees qualitatively with the decrease in basolateral membrane K transference number predicted from the increase in R_b during exposure to ouabain. The observed drop of K permselectivity of the basolateral membrane could explain, in part, the fall of E_b produced by ouabain (Table III).

Transient Changes in Cell Potential during Exposure to K-Ringer

As illustrated in Fig. 4, exposure of the tissue to K-Ringer on the mucosal side results, under control conditions, in fast depolarization of both cell membranes.

TABLE V
EFFECTS OF K-RINGER ON THE SEROSAL SIDE ON
TRANSEPITHELIAL AND CELL MEMBRANE POTENTIALS
BEFORE AND AFTER ADDITION OF OUABAIN

	30 min	60 min
ΔV_{ms}		
Control	3.6 ± 0.8	3.6 ± 0.8
Ouabain	4.6 ± 1.2	5.5 ± 1.4
<i>P</i>	NS	NS
ΔV_{mc}		
Control	55.9 ± 2.7	55.9 ± 2.7
Ouabain	49.9 ± 2.7	42.9 ± 4.0
<i>P</i>	<0.005	<0.005
ΔV_{cs}		
Control	59.7 ± 3.3	59.7 ± 3.3
Ouabain	54.6 ± 3.1	48.4 ± 4.2
<i>P</i>	<0.05	<0.025

As are the changes of potentials produced by serosal substitution of K-Ringer for Na-Ringer. Values in millivolts. Column headings indicate time of exposure to ouabain. In each preparation, all three values (control, 30 min, and 60 min) were obtained from the same cell. $n=6$ experiments.

Thereafter, V_{mc} and V_{cs} usually remain constant or undergo only small changes for a period of several minutes. After changing the mucosal medium back to Na-Ringer, all potentials return to their control values. As shown in Fig. 5, during exposure to ouabain the same substitution in the mucosal solution resulted in an immediate depolarization similar in magnitude to the one obtained in the control situation. During the period of exposure to K-Ringer, however, the cell membrane potentials did not remain constant, but hyperpolarized significantly. In addition, after returning to Na-Ringer on the mucosal side both membrane potentials became significantly more negative than the values measured in Na-Ringer before exposure to high K, and depolarized slowly thereafter. These observations can be explained by a net influx of K into the cells during exposure to K-Ringer, which results in an elevation of intracellular

K activity and, therefore, in time-dependent increases of E_a and E_b during exposure to K-Ringer and shortly after returning to Na-Ringer.

Effects of Ouabain on the Properties of the Shunt Pathway

As shown in Table II, R_s increases moderately in ouabain. For up to 2 h, the value of P_{Na}/P_{Cl} across the shunt does not change, as evidenced by the lack of change of the transepithelial 2:1 NaCl dilution potential (Fig. 6 A). P_K/P_{Na} , however, increases significantly, as shown by a progressive increase, with time,

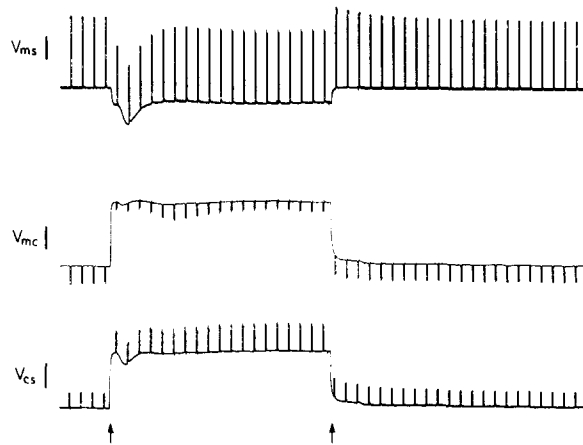

FIGURE 4. Effect of a mucosal ionic substitution (K for Na) on potentials and resistances, under control conditions. Records start with the microelectrode in a cell. V_{ms} was 1.4 mV (mucosa negative), V_{mc} was 64.5 mV, and V_{cs} was 65.9 mV (cell negative). The voltage deflections are the result of transepithelial (mucosa-to-serosa) current pulses. Mucosal superfusion with K-Ringer starts at the first arrow. The following changes are observed: depolarization of V_{mc} and V_{cs} , hyperpolarization of V_{ms} , decrease of transepithelial resistance (as evidenced by the reduction of the V_{ms} change elicited by transepithelial current), and decrease of the ratio of cell membrane resistances (compare the voltage deflections in V_{mc} and V_{cs} records before and after exposure to K-Ringer). After the transient voltage changes seen shortly after the first arrow, all potentials remain quite stable. The transient apparent change of R_a/R_b observed shortly after exposure to K-Ringer is probably caused by an unstirred layer polarization phenomenon during the current pulse (Reuss and Finn, 1977 *b*). The instantaneous deflections of V_{mc} and V_{cs} show no change of R_a/R_b during this period. At the second arrow, the tissue was superfused with Na-Ringer. All changes are reversible. Calibrations: 10 mV (V_{ms}), 20 mV (V_{mc} and V_{cs}); interval between pulses: 10 s.

of the change of V_{ms} produced by exposure to K-Ringer on the mucosal side. The immediate changes of V_{ms} are shown in Table IV. Steady-state changes of V_{ms} , obtained ca 30 s after the substitution, are summarized in Fig. 6 B. The interpretation of the latter results is complicated by the probable change of intracellular K activity (and therefore of cell membrane emfs) during the period of exposure to K-Ringer, as explained above. However, it can be shown that E_s does increase during this time. A typical value of ΔV_{ms} 5 mV larger at the steady

state than immediately after the change from Na-Ringer to K-Ringer would require an increase > 160 mV of $E_b - E_a$ during the same period. Thus, the transepithelial bionic potentials shown in Fig. 6 are caused mostly by changes of shunt emf and not of cell membrane emfs. Neglecting the latter, the control K:Na selectivity ratio of the shunt pathway is 1.38. The values obtained in ouabain are 1.54, 1.87, and 2.11, at 30, 60, and 120 min, respectively.

Effects of Ouabain on Intracellular Cation Concentrations

As shown in Table VI, after 60 min in ouabain intracellular K concentration decreased, whereas Na concentration increased. No significant change in cell volume was detected. The intracellular Na concentration values show a large

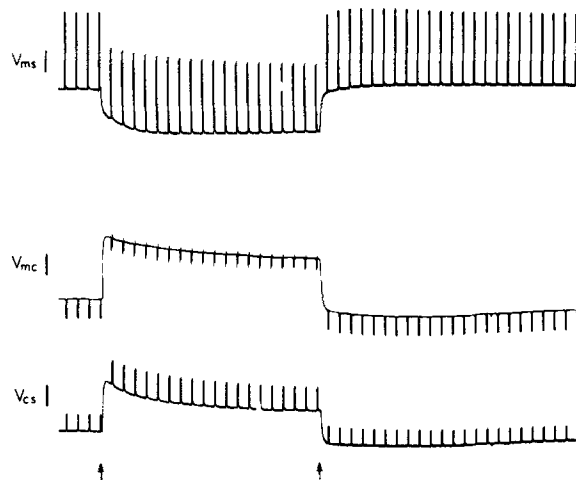

FIGURE 5. Same format as in Fig. 4. The record was obtained in the same tissue, 90 min after addition of ouabain to the serosal medium. In Na-Ringer, V_{ms} was 0.2, V_{mc} was 48.3, and V_{cs} was 48.5 mV. Exposure to K-Ringer results in progressive hyperpolarization of V_{mc} and V_{cs} after the initial depolarization. Both cell potentials "overshoot" upon returning to Na-Ringer. Slow depolarization can be seen at the end of the V_{mc} and V_{cs} traces. See text.

dispersion, and are therefore less reliable than the K determinations. For this reason, we do not ascribe particular significance to the larger value of Na + K after ouabain as compared to the control condition.

DISCUSSION

Recent studies with ion-selective microelectrodes in gallbladder epithelial cells have demonstrated that the Cl activity is higher than predicted from passive distribution, in *Necturus* (Reuss, 1979) and rabbit (Duffey et al., 1978). Intracellular Na activity, also measured with ion-selective microelectrodes, on the contrary, is far below equilibrium in *Necturus* gallbladder (range: 5 to 22 mM: Zeuthen, 1978; Reuss, 1979; Graf and Giebisch, personal communication; Spring, personal communication). It can be calculated that the electrochemical gradients across the luminal membrane are about 105 mV for Na, favoring

entry, and 39 mV for Cl, favoring exit. The demonstration of the absence of a large Na diffusional pathway at the luminal membrane (Reuss and Finn, 1975 *b*; Van Os and Slegers, 1975) and the demonstration of the requirement of both Na and Cl in the mucosal medium for uptake of either ion by the cells (Frizzell et al., 1975) indicate that the luminal membrane net flux results from a coupled,

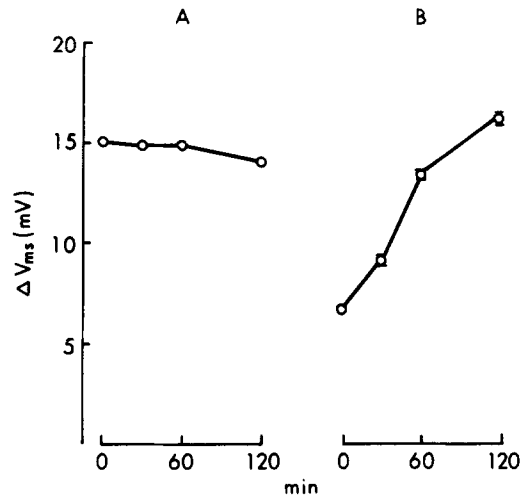

FIGURE 6. (A) Transepithelial 2:1 NaCl dilution potentials (ΔV_{ms}) before (0) and during exposure to ouabain. No significant changes are observed. $n = 6$ experiments. (B) Transepithelial K:Na bionic potentials before (0) and during exposure to ouabain. ΔV_{ms} values were measured 30 s after exposure to K-Ringer. All changes are significant ($P < 0.01$ or better). $n = 7$ experiments. Abscissa indicates duration of exposure to ouabain.

TABLE VI
EFFECTS OF OUABAIN ON INTRACELLULAR ION
CONCENTRATIONS

	Sodium	Potassium
Control	29 ± 7	96 ± 7
Ouabain	96 ± 19	44 ± 7
<i>P</i>	<0.025	<0.001

Values in milliequivalents per kilogram cell water. Gallbladders incubated for 60 min in Na-Ringer, with or without ouabain. Significance calculated from Student's *t* test for nonpaired samples. Number of experiments: 4 (Na, control), 4 (Na, ouabain), 9 (K, control), 6 (K, ouabain).

neutral, NaCl entry mechanism. Because the Na electrochemical gradient is larger than the Cl electrochemical gradient, the Na gradient could provide the energy required for translocation of NaCl across the membrane.

Na transport across the basolateral membrane is uphill. Cl transport, although downhill, is probably not entirely diffusional because of the low Cl permeability of the basolateral membrane (Reuss, 1979). This observation is consistent with

the possibility of neutral NaCl extrusion at this barrier. The experiments described in this paper were designed to gain additional information on the mechanism of Na transport across the basolateral membrane.

The Effects of Ouabain on Fluid Transport and Cell Potentials. Is the Basolateral Na Transport Mechanism Electrogenic?

Ouabain produced a rapid inhibition of spontaneous fluid transport to one-third of control in 15 min and to zero in 30 min. This result agrees with the observations of Hill and Hill (1978) and shows a faster effect than the one observed in fish gallbladder (Diamond, 1962 *a*). Although suggestive of a direct role of the Na-K pump on net salt transport, this observation does not allow one to rule out the possibility of an indirect relationship between the pump and transepithelial transport.

Slow depolarization of the epithelial cells after addition of ouabain had been previously observed by Van Os and Slegers (1975), Zeuthen (1978), and us (unpublished observations). However, no correlation with fluid transport rate under the same conditions was attempted. The most striking observations in this work are that the cell potentials are unchanged at a time when J_v has dropped to one-third of control, and that when J_v is effectively zero, cell depolarization is very small. Several lines of evidence have been taken to indicate that the basolateral Na pump in gallbladder may be electrogenic. The arguments, recently reviewed by Rose (1978), include: (*a*) the observation of rather large transepithelial "transport" potentials in gallbladders of some species (notably, man); (*b*) the observation of fast decreases of transepithelial potential during inhibition of metabolism; (*c*) the mucosa-negative change of V_{ms} induced by amphotericin B (Cremaschi et al., 1971; Rose and Nahrwold, 1976, 1977). The latter argument has been proven wrong by the demonstration that amphotericin B increases Na permeability across the luminal membrane of gallbladders of several species (Cremaschi et al., 1977; Rose and Nahrwold, 1977; Reuss, 1978). This effect accounts for the change of V_{ms} . The basolateral membrane emf drops, instead of increasing, as expected if transport were electrogenic (Reuss, 1978).

The experiments reported here do not support the hypothesis of a significant electrogenic component of the basolateral Na transport mechanism under control conditions. A quantitative argument can be put forward as follows: under control conditions, J_{Na}^{net} is equivalent to $38 \mu A \times cm^{-2}$ (see Results). Let us assume that all Na flows through the pump, and that the Na:K coupling ratio is 3:2, as in excitable tissues (Thomas, 1972; De Weer, 1975). The control pump current would be $12.7 \mu A \times cm^{-2}$. Because the control basolateral membrane resistance is $2.3 k\Omega \times cm^2$, such current would result in a voltage drop of 29 mV. This value would equal the "electrogenic component" of E_b (E_b^e). V_{mc} and V_{cs} can be calculated (Reuss and Finn, 1975 *a, b*) from

$$V_{mc} = \frac{E_a (R_b + R_s) + E_b R_a}{R_a + R_b + R_s}$$

and

$$V_{cs} = \frac{E_b(R_a + R_s) + E_a R_b}{R_a + R_b + R_s},$$

and the contributions of E_b to both potentials are

$$V'_{mc} = \frac{E_b R_a}{R_a + R_b + R_s}$$

and

$$V'_{cs} = \frac{E_b (R_a + R_s)}{R_a + R_b + R_s},$$

where ' indicates that we are subtracting E_a and the nonelectrogenic component of E_b from both potentials.

From the control values of resistances (Table II), $V'_{mc} = 20$ mV, and $V'_{cs} = 21$ mV.

If ouabain affects E_b as described above, after 15 min of exposure to the glycoside, when Na transport is reduced by 70%, V_{mc} and V_{cs} should decrease by 11 to 14, and by 12 to 15 mV, respectively. After 30 min, the reductions in potentials should be 16 to 20 and 17 to 21 mV, respectively. The minimum values are those calculated if the resistances are unchanged; the maximum values were obtained from the resistances measured between 30 and 60 min of exposure to the glycoside. In contrast to the above predictions, at 15 min V_{cs} was unchanged and at 30 min it had decreased by 6.6 mV.

It could be argued that the pump current is smaller if only a fraction of net Na transport occurs through the pump, and a sizable moiety flows, by a solvent drag mechanism, through the paracellular pathway. If such were the case, triaminopyrimidinium (TAP+), which blocks paracellular Na conductance, should produce a large decrease of fluid transport. However, TAP+ has no effect on transport rate in frog gallbladder (Moreno, 1974). To account for a change of V_{cs} of < 2 mV 15 min after ouabain, assuming an electrogenic Na pump with a coupling ratio of 3:2, it would be necessary to postulate that 87% of J_{Na}^{net} is paracellular under control conditions.

In conclusion, this argument shows that, in this tissue, the basolateral Na transport mechanism is not measurably electrogenic under normal transport conditions. It is still possible that electrogenicity can be demonstrated under different experimental situations, such as Na loading, by incubation in K-free solutions in the cold, followed by rewarming and addition of K (Whittembury, 1970), by intracellular iontophoresis, or by manipulations of intracellular ionic activities with drugs such as nystatin (Lewis et al., 1977, 1978). Note, however, that the results obtained with amphotericin B (Reuss, 1978) do not support the hypothesis of an electrogenic basolateral Na transport mechanism.

The possibility of two mechanisms of active Na transport across the basolateral membrane should be considered, as proposed for the renal proximal tubule (Whittembury, 1970). The "classic" Na-K pump could operate in an electrogenic

fashion, as in other tissues (Thomas, 1972; De Weer, 1975), *in parallel* with a neutral Na pump responsible for most of the transepithelial Na flux. The finding of a low Cl permeability of the basolateral membrane (Reuss, 1979) suggests that the neutral transport mechanism is a NaCl pump. If such were the case, J_{Na} through the Na-K pump could be a small fraction of the total J_{Na} across the membrane. Thus, the predicted reductions of cell membrane emf and potential produced by ouabain would be smaller. Transepithelial salt and water transport were completely inhibited by ouabain, indicating that if there are two transport mechanisms, the glycoside blocks both. However, the effect on the neutral pump might be indirect. Additional studies will be required to examine this hypothesis.

The Mechanism of Cell Depolarization

Both cell membranes are mainly K permeable in *Necturus* gallbladder epithelium (Reuss and Finn, 1975 *a, b*; Van Os and Slegers, 1975; Reuss, 1979). K is normally actively transported into the cell, and has a steady-state intracellular activity higher than the one expected if it were passively distributed (Reuss, 1979). One might then expect that blocking the Na-K pump should result in K loss from the cells, and this is in fact the experimental observation. Because both cell membranes are mainly K permeable, the fall of intracellular K activity causes reductions of both E_a and E_b .

Two observations, however, indicate that this is not the only mechanism of cell depolarization. First, the diminution of E_b is too large, compared with the one of E_a , according to the constant field equation solved for both membranes. If the selectivities remain constant, the fall in intracellular K activity should result in a reduction of E_a of ca 74% of the drop of E_b . Second, R_b was shown to increase by a factor of two, indicating that the K conductance of the basolateral membrane decreased. Two mechanisms account for this effect: the decrease in intracellular K activity and a drop in K transference number (or relative K permeability), as demonstrated by the reduction of the dependence of E_b on extracellular K concentration. Ouabain, therefore, reduces K permeability across the basolateral membrane. The data are insufficient to ascertain whether this effect is a direct one or is mediated by, e.g., changes of intracellular ionic composition. Helman and Nagel (1977) have observed, in frog skin, that ouabain reduces the ratio of cell membrane resistances, probably by increasing the resistance of the inner membrane. In addition, as described above, the ratio of resistances increased later on, during continuous exposure to the glycoside.

As demonstrated by the mucosal solution substitution experiments, the K selectivity of the luminal membrane remains essentially unchanged during exposure to ouabain. Thus, the observed drop of E_a can be tentatively ascribed to the fall in intracellular K concentration. R_a did not change in the period from 30 to 60 min of exposure to ouabain (Table II). At 60 min, intracellular K concentration was reduced significantly (Table VI). If apical membrane permeabilities remain constant, R_a should have increased by about 20%, and E_a should have decreased by about 13 mV (instead of the measured change of 5.2 mV). These discrepancies suggest the possibility of changes of apical membrane properties during exposure to the glycoside (e.g., relative ionic permeability

changes). However, the comparison between the electrical measurements and the determinations of intracellular Na and K concentrations is subject to a number of uncertainties, including the lack of information on intracellular activity coefficients and the fact that these two sets of measurements were obtained after different periods of incubation in ouabain. Experiments with ion-selective microelectrode will probably help to clarify this issue.

Effects of Ouabain on the Shunt Pathway

Ouabain caused an increase of R_s , no change in shunt P_{Na}/P_{Cl} (for at least 3 h), and an increase of P_K/P_{Na} , which was directly proportional to the duration of the exposure to ouabain. In a control series of experiments it was demonstrated that the change of P_K/P_{Na} was not a time-dependent, ouabain-independent phenomenon. A precise calculation of the value of P_K/P_{Na} is difficult, because of the concomitant changes of cell membrane emfs and resistances. The values given above are only approximations.

The increase of E_s caused by ouabain could be ascribed to a reduction in the width of the lateral intercellular spaces. Such a reduction has been observed in electron microscopic studies in rabbit gallbladder (Tormey et al., 1967). The effect on K selectivity with no change of P_{Na}/P_{Cl} is reminiscent of the observations in gallbladder exposed to amphotericin B (Reuss, 1978). It is tempting to speculate that junctional K selectivity increases when intracellular K falls, but the present information is insufficient to draw a definitive conclusion.

We thank M. P. Blaustein, J. M. Diamond, and S. Weinman for their comments on a preliminary version of this paper, and J. Jones for typing the manuscript.

This work was supported by grant AM-19580 from the National Institute of Arthritis, Metabolism, and Digestive Diseases.

Received for publication 6 September 1978.

REFERENCES

- CREMASCHI, D., and S. HÉNIN. 1975. Na⁺ and Cl⁻ transepithelial routes in rabbit gallbladder. Tracer analysis of the transports. *Pfluegers Arch. Eur. J. Physiol.* **361**:33-41.
- CREMASCHI, D., S. HÉNIN, and M. CALVI. 1971. Transepithelial potential difference induced by amphotericin B and NaCl-NaHCO₃ pump localization gallbladder. *Arch. Int. Physiol. Biochim.* **79**:889-901.
- CREMASCHI, D., S. HÉNIN, G. MEYER, and T. BACCIOLA. 1977. Does amphotericin B unmask an electrogenic Na⁺ pump in rabbit gallbladder? Shift of gallbladders with negative to gallbladders with positive transepithelial p.d.'s. *J. Membr. Biol.* **34**:55-71.
- DE WEER, P. 1975. Aspects of the recovery processes in nerve. In MTP International Review of Science. Physiology, Series One. Neurophysiology. Vol. 3. C. C. Hunt, editor. Butterworths & Co. Ltd., London. 231-278.
- DIAMOND, J. M. 1962 *a*. The mechanism of solute transport by the gallbladder. *J. Physiol. (Lond.)* **161**:474-502.
- DIAMOND, J. M. 1962 *b*. Mechanism of water transport by the gallbladder. *J. Physiol. (Lond.)* **161**:503-527.
- DUFFEY, M. E., K. TURNHEIM, R. A. FRIZZELL, and S. G. SCHULTZ. 1978. Intracellular

- chloride activities in rabbit gallbladder: direct evidence for the role of the sodium gradient in energizing "uphill" chloride transport. *J. Membr. Biol.* **42**:229-245.
- EISENBERG, R. A., and E. A. JOHNSON. 1970. Three-dimensional electrical field problems in physiology. *Prog. Biophys. Mol. Biol.* **20**:1-65.
- FRIZZELL, R. A., M. C. DUGAS, and S. G. SCHULTZ. 1975. Sodium chloride transport by rabbit gallbladder. Direct evidence for a coupled NaCl influx process. *J. Gen. Physiol.* **65**:769-795.
- FRÖMTER, E. 1972. The route of passive ion movement through the epithelium of *Necturus* gallbladder. *J. Membr. Biol.* **8**:259-301.
- HELMAN, S. I., and W. NAGEL. 1977. Microelectrode studies of frog skin. Effects of ouabain. *Fed. Proc.* **36**:632a. (Abstr.)
- HILL, B. S., and A. E. HILL. 1978. Fluid transfer by *Necturus* gallbladder epithelium as a function of osmolarity. *Proc. R. Soc. Lond. B. Biol. Sci.* **200**:151-162.
- LEWIS, S. A., D. C. EATON, C. CLAUSEN, and J. M. DIAMOND. 1977. Nystatin as a probe for investigating the electrical properties of a tight epithelium. *J. Gen. Physiol.* **70**:427-440.
- LEWIS, S. A., D. C. EATON, and J. M. DIAMOND. 1976. The mechanism of Na⁺ transport by rabbit urinary bladder. *J. Membr. Biol.* **28**:41-70.
- LEWIS, S. A., N. K. WILLS, and D. C. EATON. 1978. Basolateral membrane potential of a tight epithelium. Ionic diffusion and electrogenic pumps. *J. Membr. Biol.* **41**:117-148.
- LOEWENSTEIN, W. R., M. NAKAS, and S. J. SOCOLAR. 1967. Junctional membrane uncoupling. Permeability transformations of a cell membrane junction. *J. Gen. Physiol.* **50**:1865-1891.
- MORENO, J. H. 1974. Blockage of cation permeability across the tight junctions of gallbladder and other leaky epithelia. *Nature (Lond.)* **251**:150-151.
- REUSS, L. 1978. Effects of amphotericin B on the electrical properties of *Necturus* gallbladder. Intracellular microelectrode studies. *J. Membr. Biol.* **41**:65-86.
- REUSS, L. 1979. Ion conductances and electrochemical gradients across membranes of gallbladder epithelium. In *Membrane Transport Processes. Vol. 4. Cellular Mechanisms of Renal Tubular Ion Transport*. E. Boulpaep, editor. Raven Press, New York. In press.
- REUSS, L., and A. L. FINN. 1975 *a*. Electrical properties of the cellular transepithelial pathway in *Necturus* gallbladder. I. Circuit analysis and steady-state effects of mucosal solution ionic substitutions. *J. Membr. Biol.* **25**:115-139.
- REUSS, L., and A. L. FINN. 1975 *b*. Electrical properties of the cellular transepithelial pathway in *Necturus* gallbladder. II. Ionic permeability of the apical cell membrane. *J. Membr. Biol.* **25**:141-161.
- REUSS, L., and A. L. FINN. 1977 *a*. Effects of luminal hyperosmolality on electrical pathways of *Necturus* gallbladder. *Am. J. Physiol.* **232**:C99-C108.
- REUSS, L., and A. L. FINN. 1977 *b*. Mechanisms of voltage transients during current clamp in *Necturus* gallbladder. *J. Membr. Biol.* **37**:299-319.
- ROSE, R. C. 1978. Electrolyte absorption by gallbladders. Models of transport. *Life Sci.* **23**:1517-1532.
- ROSE, R. C., and D. L. NAHRWOLD. 1976. Electrolyte transport by gallbladders of rabbit and guinea pig. Effect of amphotericin B and evidence of rheogenic Na transport. *J. Membr. Biol.* **29**:1-22.
- ROSE, R. C., and D. L. NAHRWOLD. 1977. Salt and water transport by rabbit and guinea pig gallbladder. Effect of amphotericin B on NaCl influx. *J. Membr. Biol.* **37**:277-297.

- SUZUKI, K., and E. FRÖMTER. 1977. The potential and resistance profile of *Necturus* gallbladder cells. *Pfluegers Arch. Eur. J. Physiol.* **371**:109-117.
- THOMAS, R. C. 1972. Electrogenic sodium pump in nerve and muscle cells. *Physiol. Rev.* **52**:563-594.
- TORMEY, J. McD., and J. M. DIAMOND. 1967. The ultrastructural route of fluid transport in rabbit gallbladder. *J. Gen. Physiol.* **50**:2031-2060.
- VAN OS, C. H., and J. F. G. SLEGGERS. 1975. The electrical potential profile of gallbladder epithelium. *J. Membr. Biol.* **24**:341-363.
- WHITTEMBURY, G. 1970. Relationship between sodium extrusion and electrical potentials in kidney cells. In *Electrophysiology of epithelial cells*. G. Giebisch, Editor. F. K. Schattauer-Verlag, Stuttgart. 153-178.
- ZEUTHEN, T. 1977. Intracellular gradients of electrical potential in the epithelial cells of the *Necturus* gallbladder. *J. Membr. Biol.* **33**:281-309.
- ZEUTHEN, T. 1978. Intracellular gradients of ion activities in the epithelial cells of the *Necturus* gallbladder recorded with ion-selective microelectrodes. *J. Membr. Biol.* **39**: 185-218.