

# The Two-Wavelength Method of Microspectrophotometry

## I. A Microspectrophotometer and Tests on Model Systems\*

By MORTIMER L. MENDELSON, M.D.†

(From the Department of Radiotherapeutics, University of Cambridge, England)

(Received for publication, October 29, 1957)

### ABSTRACT

In spite of a number of examples of the apparently successful application of the two-wavelength method of microspectrophotometry to biological materials, a demonstration of the effective transition from the theoretical to the practical aspects of the method has never been given. The following tests were carried out on model systems in order to confirm the practical validity of the method:

(1) Spherical droplets of Sudan blue or Sudan IV (varying in volume by as much as 400 times) were measured with the surrounding blank field included and were found to have amounts of chromophore which conformed to the estimated droplet volume to within 3 to 6 per cent.

(2) Repeated determinations on the same isolated nucleus gave results which did not vary in spite of wide variations in the area of the photometric field.

(3) The results of repeated determinations on the same droplet of dye were unaffected by gross changes in the focus of the objective.

The microspectrophotometer on which these measurements were made has been briefly described; it was designed specifically for the two-wavelength method. Some of the details of instrumentation have been discussed, in particular, the effects of non-uniform illumination and the contrasting demands of the two integral parts of this type of photometry. Although it has certain limitations, the two-wavelength method conforms to its theoretical promise and is a practical method of measuring light absorption in complex objects.

In 1951, Ornstein presented a theoretical discussion of the absorption laws for light and a formulation of the two-wavelength method of avoiding distributional error (6). He defined distributional error as, "the error introduced into a photometric calculation by using the total measured transmittance of a photometric field as if that field contained a uniform and random distribution of chromophores, when in fact, the field contains a non-uniform distribution." Patau followed soon after, with a restatement of the two-wavelength method, criteria for the choice of

wavelengths, a table for the calculations involved, and some examples of the application of the method to the measurement of the Feulgen stain-content of nuclei (7). A number of reports have since appeared in which the method has been employed (3-5, 8, 10, 11).

The two-wavelength method is an empirical extension of the exact solution for a simple type of heterogeneity in which the photometric field is divided into two homogeneous compartments. The average transmission is determined at two wavelengths which give an absorbance of 1:2 for a homogeneous field. By the use of simultaneous equations, it is then possible to calculate the average absorbance free of distributional error. The application of the method to situations extending beyond the simple one is justified by the observation that a wide variety of distributions, including those expected in biological materials, will theoretically give results in which the distri-

\* This work was carried out during the tenure of a British-American Exchange Fellowship of the American Cancer Society, Inc., and a Fellowship from the Jane Coffin Childs Memorial Fund for Medical Research. Support was also obtained from the Sloan Fund.

† Present address: Department of Radiology, Hospital of the University of Pennsylvania, Philadelphia.

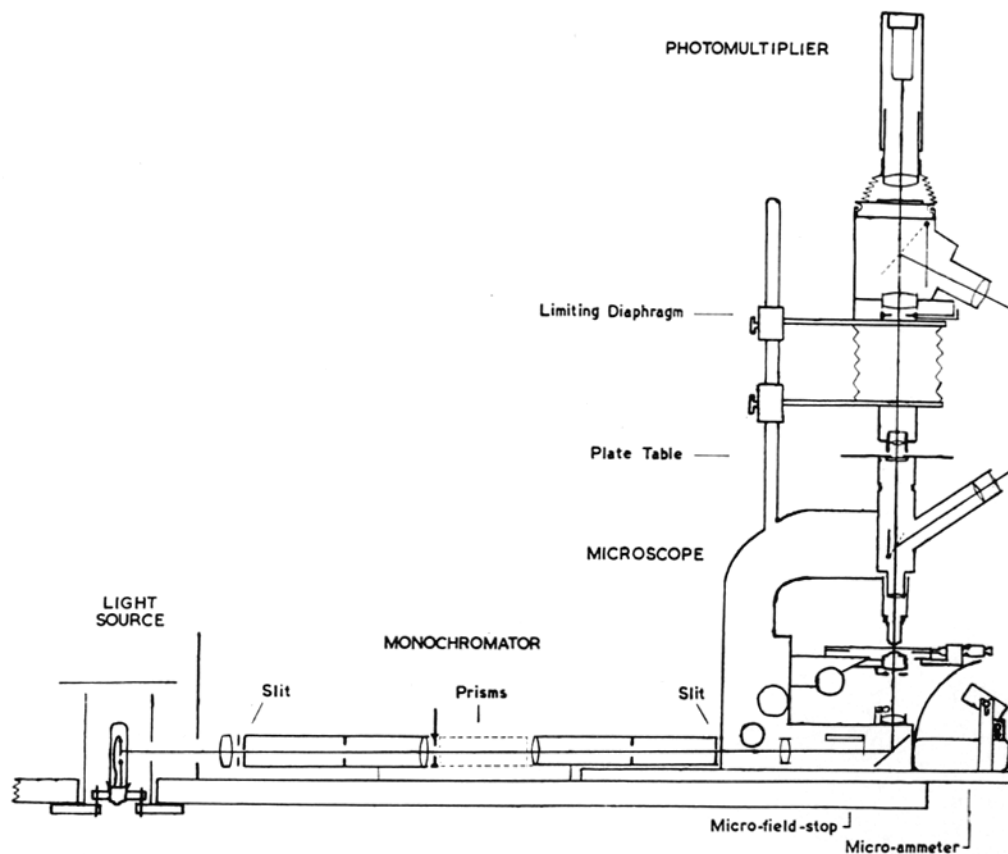

FIG. 1. A schematic diagram of a microspectrophotometer designed for use with the two-wavelength method.

butional error is reduced to a negligible value (6, 7).

Patau and Swift have analyzed some of the requirements for instrumentation, and made the first attempt to realize the potentialities of the method (8). They measured the Feulgen stain-content of a sample of nuclei in various stages of mitosis in the root tip of onion, hoping to demonstrate a constancy of the values. Although the interphase, prophase, and telophase cells gave a constant amount of measured stain, the metaphase and anaphase forms gave somewhat higher values. The interpretation of these results is limited by two considerations: they were using an improvised instrument which suffered from non-uniform illumination; and they were simultaneously testing the constancy hypothesis and the technique of measurement against each other. Some instrumental sources of error have been described by Moses and Taylor, using the same object under fixed conditions of measurement (5). The other publi-

cations have indicated the superiority of the two-wavelength method over the plug technique when dealing with heterogeneous objects, but have gone no further in the experimental verification of the method's validity.

In an attempt to remedy this situation, the two-wavelength method has been tested by means of several model systems. The interpretation of these results inevitably involves the measuring instrument as well as the method; hence, a brief description of the microspectrophotometer will be presented.

#### *The Microspectrophotometer:*

A schematic diagram of the instrument, shown in Fig. 1, indicates the conventional arrangement of light source, monochromator, microscope, and photomultiplier (9). The particular features which are pertinent to the two-wavelength method are the micro-field-stop, the collecting and viewing system for the projected image of the object, and the precautions against glare, chromatic contamination, and non-uniformity of illu-

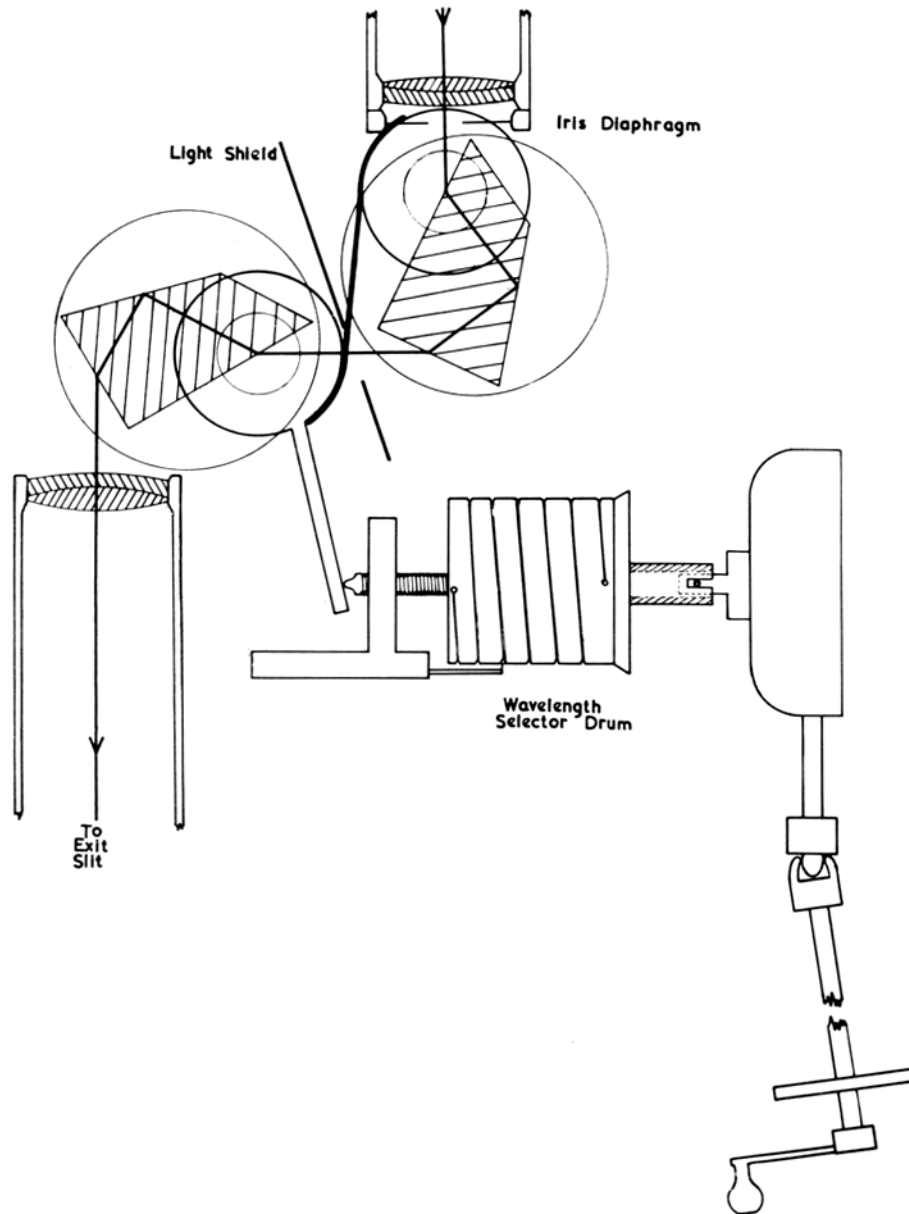

FIG. 2. A diagram of the monochromator, showing the details of the mechanism for selection of wavelengths and the optical components.

mination. The plate table, which is also shown in the figure, will be discussed in paper III of this series.

The instrument has been assembled about the Cooke, Troughton, and Simms Model M 4001 microscope. The objective is a  $95\times$ , fluorite, with a N.A. of 1.3. Two  $10\times$  Kellner eyepieces are used. A Beck immersion condenser, N.A. 1.3, has been fitted with a mechanical stop to reduce the aperture to 0.3. A 6 volt ribbon filament source is imaged onto the prisms of the mono-

chromator, and onto the stage of the microscope. The monochromator (Feuss) is based on a pair of constant deviation glass prisms. It has a N.A. of 0.45. The details of the prisms, control mechanism, and crude field-stop are shown in Fig. 2. The pair of achromatic doublets shown in the base of the microscope form a non-magnified image of the slits in the focal plane of the condenser. Midway between the lenses, at the point where an image of the filament is formed, a (micro-

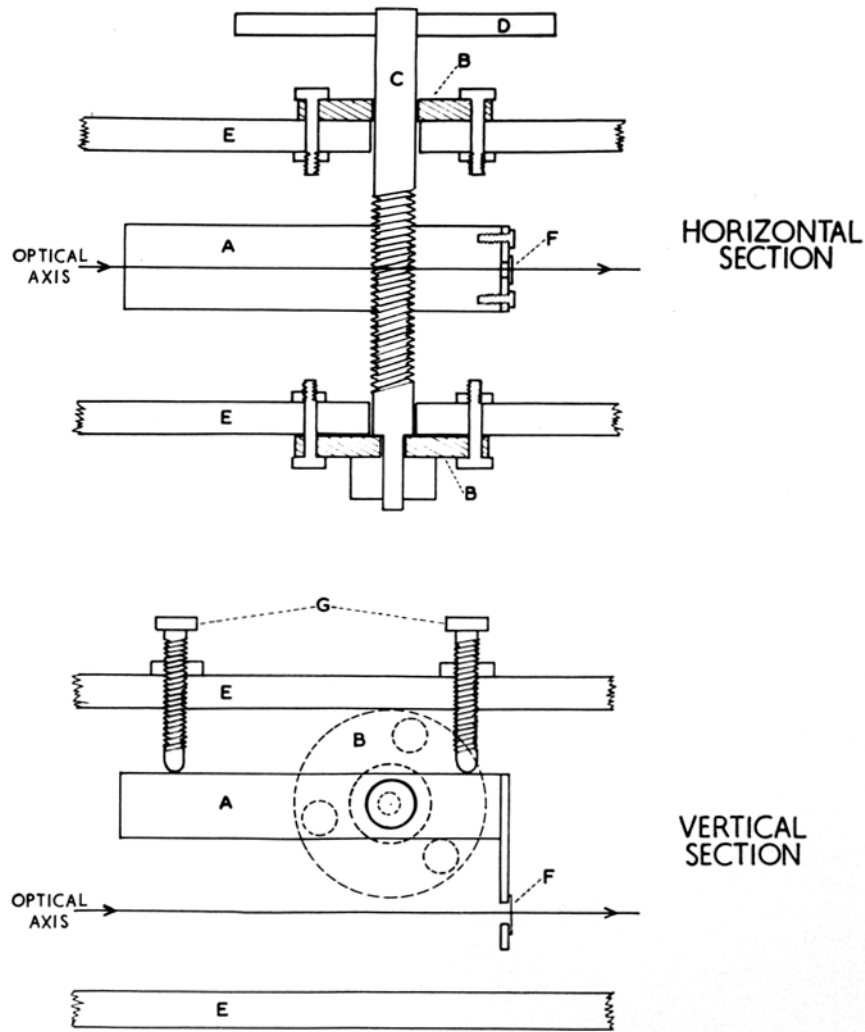

FIG. 3. Schematic diagrams of the micro-field-stop. *A*, brass block; *B*, bearings; *C*, spindle for horizontal control; *D*, handle of spindle; *E*, body of microscope; *F*, aluminum foil window; *G*, screws for vertical control.

field-stop has been mounted, as shown in Fig. 3. The window of aluminum foil has been punctured with a series of graded holes by means of fine glass drills. Any one of these holes, or stops, can be rapidly positioned on the optical axis by means of the vertical and horizontal controls. The stops form circular images in the plane of the object with diameters of 2.8, 8.5, 18.5, and 28.5 microns. The device can be readily tilted out of the path of light. An auxiliary light source has been mounted below the condenser to aid in the search for and identification of objects when using the micro-field-stop.

There are two movable front-surfaced mirrors in the assembly. The lower mirror acts as a shutter and reflects the image into a monocular side tube. The upper mirror permits the image to be projected after it has

been focused in the plane of the limiting diaphragm. This projection forms an eyepoint at a convenient distance from the microscope and allows the image to be viewed in relation to the photometric field. The limiting diaphragm which defines this field has been calibrated so that its diameter can be determined from the lever which controls its movement. An  $f$  4.5, 13.5 cm. Tessar lens is positioned immediately above the diaphragm. When uninterrupted by the mirror, the beam passes through a blue filter and is focused on the photocathode as the greatly demagnified image of the slits. An EMI, 11 stage, class B type 6094 photomultiplier has been used, and it is powered by a battery pack. The signal is fed to a d.c. transistor amplifier and then to a calibrated micro ammeter.

Various stops have been inserted in the optical train

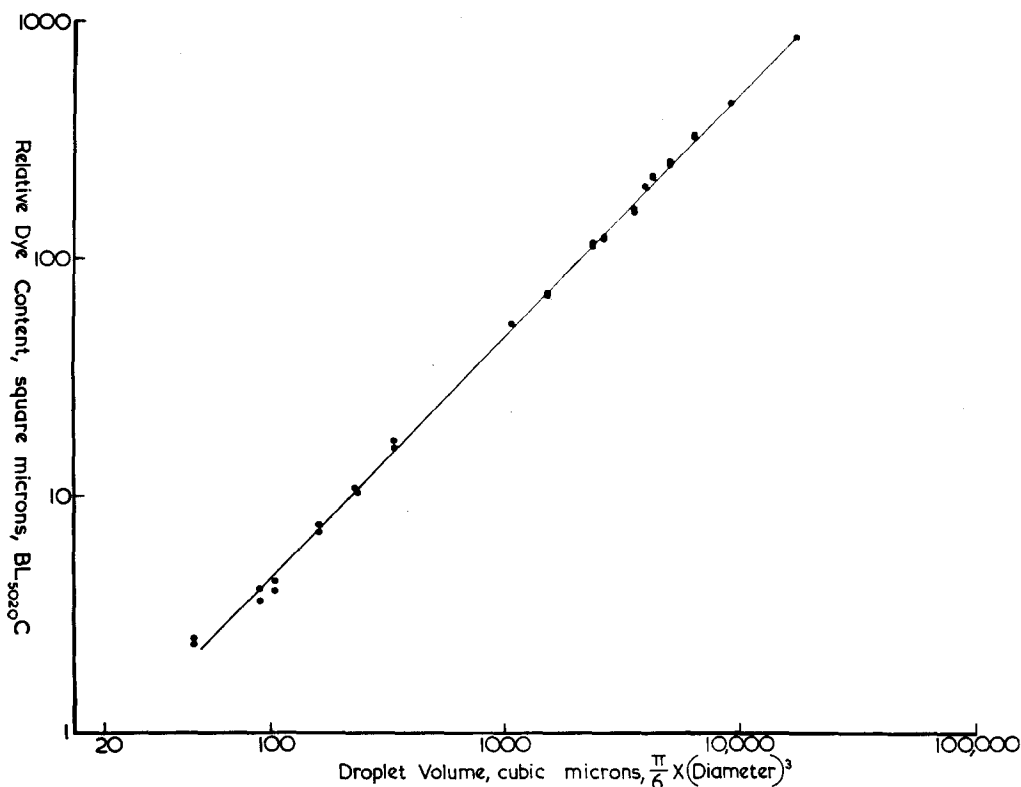

FIG. 4. Two-wavelength and micrometer measurements of droplets of Sudan blue.

to minimize stray light. A black object, the size of a mammalian nucleus, has a transmission of less than 0.5 per cent when illuminated by the micro-field-stop. The elimination of glare has been particularly important in the monochromator, since here, stray light results in chromatic contamination. The adequacy of the monochromator was confirmed by the following tests. Direct examination of the emission with a viewing spectroscopy showed only a single line at all settings in the visible range. The absorption curves of glass filters were identical whether determined on the microspectrophotometer or determined on a Beckmann D.U. spectrophotometer. Finally, the measured density of colored step wedges at various wavelengths gave a series of straight lines passing through the same intercept (11). The monochromator has been set to a 20 Å slit-width and has been calibrated by means of the yellow lines from a mercury source.

The stability of the instrument permits the four measurements necessary for the two-wavelength method to be obtained without significant noise or drift. The response of current to the area of the photometric field is linear to within 0.5 per cent over a range of 10 times. The variation in intensity within the photometric field is well under 5 per cent.

#### Tests on Model Systems:

Pollister and Ornstein (9) have described a model in which droplets of olive oil saturated with Sudan IV (scarlet red) are suspended in a mixture of gelatin, glycerin, and water. After a good deal of trial and error, preparations were made with a reasonable concentration and distribution of droplets, and with no evidence of refractive differences between the droplets and the medium. These have been tested and found satisfactory, but attention has been focused primarily on the same model using Sudan blue (G. Gurr).

The wavelengths 5020 and 5300 Å were evaluated on the central core of droplets, and on a large droplet which was purposely flattened between slide and coverslip. They gave a ratio of absorbance of 1:2.01. Eighteen droplets were chosen which were well isolated from each other, were not touching either boundary, and represented a wide range of diameters. The series was measured twice by the two-wavelength method (7), with a liberal margin of blank field about each droplet. The diameter of the droplets was determined with an

TABLE I  
Analysis of Variance of the Ratio of Absorbance to Volume in Droplets of Sudan Blue

Source of variation	Degrees of freedom	Sum of squares	Mean square
Group (pairs) . . . . .	17	1.0058	0.05917
Individuals . . . . .	18	0.13283	0.007379
Total . . . . .	35	1.1386	0.03253

Standard deviation of group means 6.55 per cent of mean.

Standard deviation of individuals 3.27 per cent of mean.

Standard deviation of droplets 6.12 per cent of mean.

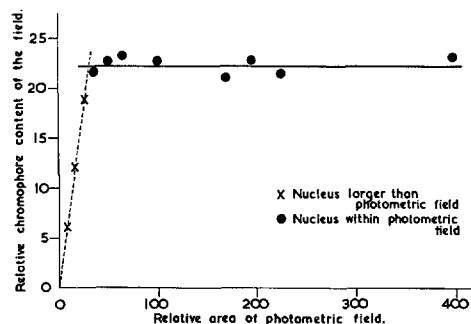

FIG. 5. The effect of field-size on the two-wavelength measurements of an isolated nucleus stained with galloycyanin-chrome alum.

eyepiece micrometer (using a N.A. of 1.0 and white light). A range of diameters of 4.50 to 32.6 microns was obtained.

The results are shown in Fig. 4. The amount of chromophore has been plotted on a log log scale against the calculated volume of the droplet. The statistical analysis summarized in Table I was done on the parameter: amount of chromophore/diameter<sup>3</sup>. It is important to realize that a standard deviation of 1.8 per cent in the estimation of droplet diameter would account for the entire droplet variation of 6 per cent. For the smaller droplets this is not an unreasonable estimate; therefore, the standard deviation of the photometric component probably approaches 3 per cent. From this, it would appear that the instrument and the two-wavelength method were reliable over a range of  $4 \times 10^2$  with an error that is well within the limits necessary for biological measurements. Results such as these have been

TABLE II  
The Effect of Field Size on the Two-Wavelength Measurements of an Isolated Nucleus Stained with Methyl Green

Area of photometric field	Amount of chromophore in the field, arbitrary units
sq. $\mu$	
63.4	14.3
68.3	15.0, 15.2
77.3	17.9
81.7	15.5
88.0	15.5
109.0	15.8, 14.9
171.0	16.8, 15.4
247.0	15.3, 15.1
Mean . . . . .	15.56
Standard deviation of mean . . . . .	0.28 (1.8 per cent)

obtained several times with both Sudan blue and Sudan IV.

According to theory, an object which is isolated in an otherwise empty area of the slide should give the same results when measured over a wide range of field sizes. This has been tested in the following ways. Fig. 5 shows the results obtained when a small dense nucleus (stained with galloycyanin-chrome alum) was measured in duplicate at a variety of different settings of the limiting diaphragm. The values obtained were constant over the wide range of field sizes which included the entire nucleus. Using the Swift and Rasch (11) method of calculating distributional error (but basing it on the wavelength with the lower absorbance and hence the smaller error), the measurements in the small fields involve a distributional error of 15 per cent, and this value increased to 30 per cent with the increase in field size. This particular series was measured at a transitory stage in the evolution of the microspectrophotometer. The performance of the final stage of the instrument is shown in Table II. These measurements are from an isolated nucleus stained with methyl green. The first measurement listed was made with the limiting diaphragm set to barely circumscribe the nucleus; however, some of the image was probably overlapped. Each value in the table represents a single set of two-wavelength measurements. Where two values are stated on the same line, they were obtained after resetting the limiting diaphragm.

TABLE III  
*The Effect of Focus on Two-Wavelength Measurements  
 of a Droplet of Sudan Blue*

Focus	Relative field size	Relative amount of chromophore	Comments
$\mu$			
0	100	100	In focus
+2	100	99	
+4	100	101	
+6	100	98	No recognizable image
+8	100	90	Absorption extends beyond photometric field
0	156	100	In focus
+8	156	104	Absorption within photometric field

The final test was based on the expectation that the two-wavelength method would give results which were independent of focus, provided the light passing through the object was all included in the photometric field. For the measurements shown in Table III, a Sudan blue dye droplet was used. The zero refers to the droplet in sharp focus, and the other settings were obtained by turning the fine focus control of the microscope upwards. These results conformed to the theory, but it is important to emphasize that the same would not be true for a similar alteration in condenser focus. The presence of slits in the light path means that deviation of condenser focus destroys the uniformity of illumination and distorts the values obtained by the two-wavelength method.

#### DISCUSSION

Although the importance of uniformity of illumination has been stressed by Patau and Swift (8), the effect of deviations from the ideal has not been defined. Some insight into the significance of non-uniformity can be gotten from the following calculations. It can be shown that a 20 per cent reduction in the intensity within half of the photometric field will have these effects on the results obtained with the two-wavelength method: with the object and the blank field sharing the non-uniformity equally, a 0 per cent error results; with the object completely within the part of the field with the lower intensity, a +9 per cent error results; and with the object completely within the part of the field with the high intensity, a -13 per cent error results. These effects are independ-

ent of the absorbance of the object. Intermediate distributions give smaller errors. Therefore, the worst possible distribution of non-uniformity results in a percentage error in the estimated amount of chromophore which is approximately half of the percentage variation in light intensity. All other types of distribution, including those seen in practise, give errors which decrease progressively as the pattern becomes randomized.

It is important to emphasize that uniformity of illumination in the sense used in the above argument includes uniformity of response of the photodetecting system. Thus, the same errors will arise if the light flux is uniform, but the phototube detects with varying efficiency rays which have passed through different parts of the field. Although this source of error is commonly dealt with by an auxiliary lens system which is situated behind the limiting diaphragm and which focuses the image of the slits on the face of the photocathode, the choice of lens components is of some importance. Both spherical and chromatic aberration in this lens system will result in residual correlations between the position of the entering rays and their final point of arrival at the photocathode. In the instrument just described, satisfactory results were not obtained until the cemented doublets originally used to collect the light were replaced with a well corrected (Tessar) system.

The two-wavelength method divides itself into two distinct operations, each requiring different optical conditions. Of these, the first is the determination of the absorption curve of the chromophore. With biological material, the areas of a specimen presenting the homogeneous properties necessary for this determination are likely to be extremely small. The measurement of minute areas is subject to error due to glare, and this error is accentuated by the requirement that the absorbance must be determined over a range of two. To avoid this error, it is essential to reduce the area of illumination to a size comparable to the area of measurement. When these areas are near the limits of optical resolution, the appearance of fringes precludes uniformity of illumination; but fortunately, it is not necessary for the illumination to be uniform when measuring homogeneous objects which completely fill the photometric field. The second operation, the measurement of transmission of objects at the defined wavelengths, is relatively insensitive to glare (7), and, as already indicated, requires uniformity of illumination. In this case, it is best to leave a reasonable margin of

illumination around the photometric field, rather than risk a fall off of intensity at the edges. The wide range of field-stops which these two operations demand of the instrument makes it necessary to incorporate a highly flexible mechanical system such as the micro-field-stop described above.

Spherical dye droplets are heterogeneous objects according to Lambert's law. When used to test the two-wavelength method, they have the disadvantage that they all give the identical type of distribution. Thus, there is a possibility that a residual error is present throughout the entire series. Ideally, one wants models with a variety of distributions and concentrations of chromophore, but the concomitant difficulty of knowing the predicted amount of chromophore in each would be insurmountable. To a certain extent, the test using different field sizes avoids this objection.

The lack of effect of field size on the measurements obtained from isolated objects permits considerable latitude in the technique of measurement. However, an unnecessarily large field increases the risk of error due to non-uniformity of illumination, and also decreases the accuracy of the estimate of transmission (7). At the other extreme, a very close fit introduces the possibility of losing pertinent information from the object, and will be very troublesome if associated with any refractive differences between the object and its mounting medium. Because of this latitude, there is a definite advantage to having a series of fixed stops instead of a limiting diaphragm. This permits the use of shapes other than the circular, and avoids the errors associated with repeated estimation of field size. This modification will not apply to objects, such as the nuclei of intact cells, which require careful fitting to avoid the confusing effects of surrounding structures.

These results have confirmed the predicted validity of the two-wavelength method, and indicate that reliable and readily obtainable measurements can be made with straightforward instrumentation. With appropriate specimens, it is quite possible to measure 50 nuclei an hour with an accuracy that is well within the variation found in populations of nuclei with supposedly constant amounts of nu-

cleic acid. The method is not as elegant or as rapid as some of the scanning devices which have been described (1, 2); but it avoids the expense and maintenance problems which these instruments entail, and gives equivalent corrections for distributional error. For specimens with a finite thickness, such as intact cells, the two-wavelength method has a distinct advantage in that it can measure accurately beyond the depth of focus of the objective. As originally described, the method has two major drawbacks. The first of these is the calculations which are very laborious, and the second is the limitations imposed by the spectral requirements of the object. Each of these is the subject of a further communication on the method.

#### SUMMARY

A microspectrophotometer suitable for two-wavelength determinations is described. The two-wavelength method has been tested on a variety of model systems, and has been found to meet the theoretical standards claimed by its originators. Some of the special requirements of the method are discussed.

#### BIBLIOGRAPHY

1. Caspersson, T., Jacobsson, F., and Lomakka, G., *Exp. Cell Research*, 1951, **2**, 301.
2. Deeley, E. M., *J. Sc. Instruments*, 1955, **32**, 263.
3. Firket, H., Chevremont-Comhaire, S., and Chevremont, M., *Nature*, 1955, **176**, 1075.
4. Merriam, R. W., and Ris, H., *Chromosoma*, 1954, **6**, 522.
5. Moses, M. J., and Taylor, J. H., *Exp. Cell Research*, 1955, **9**, 474.
6. Ornstein, L., *Lab. Inv.*, 1952, **1**, 250.
7. Patau, K., *Chromosoma*, 1952, **5**, 341.
8. Patau, K., and Swift, H., *Chromosoma*, 1953, **6**, 149.
9. Pollister, E. W., and Ornstein, L., in *Analytical Cytology*, (R. C. Mellors, editor), New York, McGraw Hill Book Company, 1955, 3.
10. Setterfield, G., Schreiber, R., and Woodard, J., *Stain Technol.*, 1954, **29**, 113.
11. Swift, H., and Rasch, E., in *Physical Techniques in Biological Research*, (G. Oster and A. W. Pollister, editors), New York, Academic Press, Inc., 1956, **3**, 354.