

# A Kinetic Model for the Action of Xylocaine on Receptors for Acetylcholine

A. B. STEINBACH

From The Rockefeller University, New York 10021. Dr. Steinbach's present address is the Department of Biophysics, University College, London W. C. 1, England. After 1 September 1968 his address will be Department of Anatomy, Albert Einstein College of Medicine, Yeshiva University, Bronx, New York 10461

**ABSTRACT** A kinetic scheme postulating the rapid formation of a partially active acetylcholine-receptor-drug complex from Xylocaine (or a derivative) and the active acetylcholine-receptor complex can account for the effects of Xylocaine and its derivatives at the neuromuscular junction. Transmembrane currents generated by an analogue computer programmed according to the scheme can exactly match end plate currents produced by nerve stimulation in the presence of the drugs. The scheme also accounts for the qualitatively different effects of the drugs on the end plate potential and on responses to iontophoretically applied acetylcholine. The analysis presented is consistent with very rapid reactions between acetylcholine and receptors, characterized by rate coefficients in the range  $10^4$  to  $10^6$  sec<sup>-1</sup>. It is based on the hypothesis that the activation of receptors by acetylcholine changes the structure of the receptors and thus their affinity for Xylocaine. The analysis does not require pharmacological separability of sodium and potassium conductances during the end plate current.

Procaine, Xylocaine, and derivatives of Xylocaine depress and modify the response of the postsynaptic receptors of the neuromuscular junction to acetylcholine (ACh) (22, 25). The most striking aspect of the effects of these drugs is the production of a prolonged component of the end plate potential (e.p.p.) that cannot be ascribed to an anticholinesterase action. In this respect, and in many other details, the actions of the drugs differ greatly from that of *d*-tubocurarine (*d*-TC) and other chemicals that also depress the response of receptors. However, the site of action of Xylocaine and procaine, like that of *d*-TC, appears to be at the postsynaptic receptors (22, 25). This suggests that these drugs modify the kinetics of the receptor response, although they do not produce a response themselves. Thus, an analysis of the effects of Xylocaine and procaine at the neuromuscular junction should offer the opportunity to find out more about the receptors themselves.

Although this article considers explicitly only the effects of Xylocaine (lidocaine, lignocaine) and its chemical derivatives, the conclusions reached probably apply to procaine as well. A model for the action of procaine has already been proposed (22). To formulate this model, Maeno investigated the action of procaine on the externally recorded miniature end plate potentials (e.m.e.p.p.'s) and the changes in the "shunting" effect of the e.p.p. (5) on the muscle action potential during treatment with the drug. These studies led to a hypothesis that procaine depresses the increase in conductance for sodium ions during the early phase of the e.p.p., and also promotes a prolonged residual sodium conductance increase to produce the prolonged phase. Using an electrical circuit model for the end plate membrane with separate time-dependent resistances to represent the suggested separate ionic channels for potassium ions and sodium ions, Maeno found that it was possible to qualitatively reproduce the e.p.p.'s observed in muscle fibers treated with procaine. Maeno's explanation, which will be considered in more detail, is based on a method of analysis quite different from that used in the present case. I shall begin by considering the normal reaction between ACh and receptors, and then utilize what is known of the action of d-TC as a basis for considering the action of Xylocaine on the receptors. The resulting model for the action of Xylocaine and its derivatives is expressed first as a scheme of chemical reactions and then as the relevant set of differential equations, which can be solved by a small analogue computer. The output of the computer was used to generate a transmembrane current at the muscle end plate, and the model was tested by compensating or balancing the physiological end plate current in chemically treated muscles with the computer-generated current.

#### MATERIALS AND METHODS

The preparation, recording techniques, and drug solutions used were the same as described previously (25). In testing the kinetic scheme, the following procedure was used. A Donner model 3500 analogue computer was programmed to solve the set of differential equations describing the model (Appendix 1). A shaped voltage pulse at the input of the computer (corresponding in time course to the pulse of ACh released by the nerve terminal) produced a voltage at the output. The output of the computer was connected to a 10 megohm resistance and thence to a second micropipette inserted into the end plate region of the fiber being studied; thus current was injected into the fiber. The preparation was treated with Xylocaine, one of its derivatives, d-TC or about 8 mM magnesium ion (4) until an e.p.p. of low amplitude was obtained upon nerve stimulation. The injected current was adjusted in over-all time course and amplitude, by changing the parameters of the computing circuit, to balance the flow of current produced by the activated end plate following nerve stimulation, and thus to maintain the muscle fiber at resting potential throughout the duration of the e.p.p. When this balance was achieved, the current injected (monitored with a series resistance, see Fig. 1) was the end plate current. The muscle membrane was thus used as a null detector to permit a direct determination of the time course of the end plate

current. This method cannot deal with negative resistances, as can the conventional voltage clamp using electronic feedback (28). However, it should be noted that in the present case the balancing current was generated according to a scheme that could be analyzed to determine the kinetic parameters of the generating process. A block diagram showing the connections between the computer, the preparation, and the recording devices is given in Fig. 1. The operation of the computer is discussed in Appendix 1.

#### THE MODEL KINETIC SCHEME

In a preceding article (25) the effects of Xylocaine and its derivatives at the neuromuscular junction were described, and the following three part hypoth-

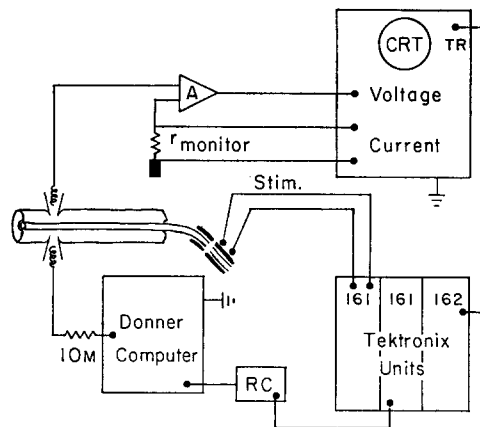
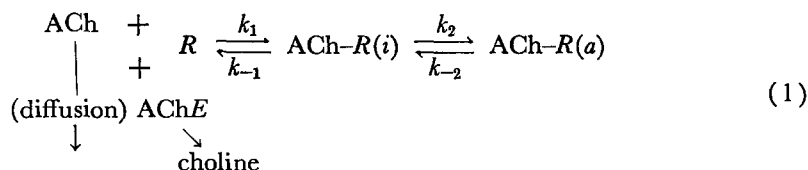

FIGURE 1. Block diagram of equipment required for tests of the kinetic model. The muscle fiber is shown impaled with two micropipettes, one connected to the recording amplifier and the other to the output of the computer. The computer input comes from a Tektronix 161 pulse generator. The solid rectangle connected to the resistance labeled  $r$  monitor indicates the indifferent electrode. The monitor resistance normally had a value less than 10 kohm, and current flow through it was displayed by recording voltage across it differentially. Alternatively, current produced by the computer output could be monitored with a small resistance (not shown) in series with the 10 megohm resistor.

esis was suggested. (a) The drugs do not significantly reduce the rate of rise of the e.p.p. because they do not appreciably inhibit receptors before the beginning of the ACh-receptor reaction. (b) They reduce and curtail the early brief component of the e.p.p. by strongly inhibiting the ACh-receptor reaction once it has begun. (c) Some drugs produce a prolonged component of the e.p.p. by promoting the continuing activity of some of the ACh-receptor complex formed during neuromuscular transmission. This latter effect is always preceded by strong inhibition, as shown by the effects of pulses of drug applied after pulses of ACh (25).

To evaluate this hypothesis, it is convenient to adopt a formal kinetic equation describing the reaction of ACh with receptors (7-9).



Reaction 1 states that ACh reacts reversibly with receptors ( $R$ ) to form first an inactive ( $i$ ) and then an active ( $a$ ) complex; it is the active complex that in some unknown way produces a permeability change in the postsynaptic membrane, and thus a flow of end plate current and depolarization of the muscle fiber (5, 13).

Both a low temperature coefficient for the response of receptors (17, 26) and stoichiometric relations between physiological release of ACh and receptor response (10, 20, 21) support the reaction scheme diagrammed in reaction 1.

d-TC appears to be a reversible competitive inhibitor of receptor response (2, 15). Bath concentrations of d-TC reduce the amplitude of the e.p.p. without appreciably changing its time course, probably because (*a*) d-TC forms inactive complexes with receptors in the absence of ACh and (*b*) the steady-state "concentration" of the d-TC-receptor complex is not significantly changed by the reaction between ACh and receptors during neuromuscular transmission because of the relatively slow association and dissociation of the d-TC-receptor complex, indicated in studies of the effects of iontophoretic application of d-TC (7, 13, 25).

A simple kinetic scheme that provides the basis of a model for the action of Xylocaine is given by reaction 2 which should be considered in conjunction with reaction 1

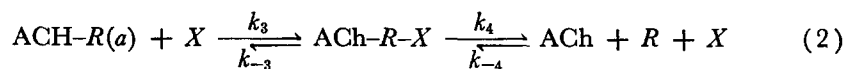

The stable complex ACh-R-X formed by reaction (2) is the essential part of the kinetic model. The symbol  $X$  denotes Xylocaine or one of its analogues, and the reaction to form ACh-R-X is assumed to be about as rapid as the reactions between ACh and receptors. The dissociation of the ACh-R-X complex is postulated to be comparatively slow. The ACh-R-X complex is assumed to be partially active (and to produce a prolonged permeability change because of its stability) or inactive, depending on the Xylocaine derivative used. All these assumptions follow from experimental observations. Thus, in the model as written, the decrease in the early peak of the e.p.p. is due to the rapid conversion of the ACh-R( $a$ ) complex into the less active or inactive ACh-R-X complex, and the prolonged component, if present, results from the low level activity of the stable ACh-R-X complex. Any decrease in amplitude of the e.p.p. resulting from a d-TC-like action of Xylocaine is not incorporated explicitly into the model (see Discussion).

One may write a simple equation relating the normal end plate current ( $I_{\text{end plate}}$ ) to the concentration of activated receptors (using chemical symbols in brackets to indicate concentration):

$$I_{\text{end plate}} = \alpha[\text{ACh} - R(a)] \quad (3)$$

where  $\alpha$  is a proportionality constant.

Equation (3) is a valid approximation only for end plate currents of low amplitude. If Xylocaine is present in the solution bathing the preparation, some ACh- $R$ - $X$  complex will be formed during application of ACh, and the end plate current will depend on the concentration of this complex as well. In this case

$$I_{\text{end plate}} = \alpha[\text{ACh} - R(a)] + \alpha_x[\text{ACh} - R - X] \quad (4)$$

In equation (4)  $\alpha_x$  is also a proportionality constant. The ratio  $\alpha_x/\alpha$  is defined as the relative activity of the ACh- $R$ - $X$  complex. For convenience in later computations  $\alpha$  was set equal to 1, so that  $\alpha_x/\alpha = \alpha_x$ .

The concentration of Xylocaine ( $X$ ) is constant throughout a given experimental test of the model (considering bath application only), because the volume of the synaptic space is small compared with the total volume of solution (3), and because there appear to be no effective barriers to diffusion into this space (7, 16).

To simplify the differential equations describing the model, the effective concentration of receptors ( $R$ ) will be assumed to remain constant during transmission. Waser (30) has estimated that fewer than 10% of the ACh receptors in the rat diaphragm are activated during transmission. Saturation of receptor responses, which would occur if the number of receptors available during transmission were not large, is not normally observed (14). In the rat diaphragm, iontophoretically applied pulses of ACh (calculated to produce peak concentrations of zero to  $2 \times 10^{-5}$  M ACh near the receptors) produce up to 10 mv potential changes and no sign of saturation (20).

The postulate that the ACh- $R$ - $X$  complex is very stable leads to the assumption that the value of the rate coefficient  $k_{-3}$  is small relative to other rate coefficients. As a simplification,  $k_{-4}$  was also assumed to be negligibly small; the justification for this will come from the experimental tests of the model.

It is convenient to lump all the reactions leading to the formation of ACh- $R(a)$  into a single reversible reaction, and thus to write the active complex as ACh- $R$  henceforth. The error introduced by this approximation is slight, and primarily affects the very early rising phase of the e.p.p.

In a form that can be tested, the kinetic scheme appears as below in reactions 5 and 6

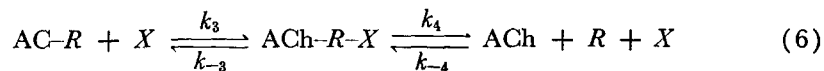
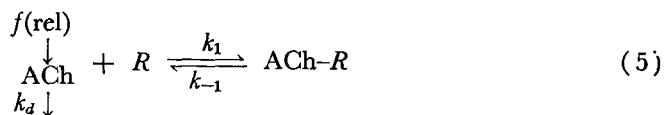

The value of  $k_d$ , a first-order rate coefficient, is determined by the processes of diffusion and hydrolysis of ACh by AChE. The notation  $f(\text{rel})$  is used to indicate the processes that provide ACh to the reaction scheme (e.g., release by the nerve or from a pipette).

Working from reactions (5) and (6) and incorporating the assumptions discussed, it is possible to describe the kinetic scheme in terms of a set of differential equations whose solutions can be programmed on an electronic analogue computer (see Methods). The objectives of the tests using the computer as a source of transmembrane current were (a) to determine whether the kinetic scheme was adequate to describe the action of Xylocaine (that is, to determine whether the computer-generated current would balance all end plate currents) and if so, (b) to determine the values of the parameters involved in the scheme. The differential equations and the equations describing the operation of the computer circuits are given in Appendix 1. The pertinent effective rate coefficients in the kinetic scheme are:  $k_1R$ ,  $k_{-1}$ ,  $k_3X$ ,  $k_4$ , and  $k_d$  (dimension:  $\text{sec}^{-1}$ ), and these can be shown to correspond in a one-to-one fashion with values of parameters in the computing circuit. The relative activity of the ACh-R-X complex ( $\alpha_X$ ) was adjustable from 0 to 1. In all tests reported here,  $k_1R$  was set equal to  $10^4 \text{ sec}^{-1}$  and  $k_{-1} = 5 \times 10^8 \text{ sec}^{-1}$ . Values of  $k_4$  from 5 to  $40 \text{ sec}^{-1}$  were used and values of  $k_3X$  from 0 to  $10^4 \text{ sec}^{-1}$ . The value assigned to  $k_d$  was  $5 \times 10^8 \text{ sec}^{-1}$  (see Appendix). Balance was defined as the nulling of at least 70% of the physiological e.p.p. The optimal values of each parameter necessary for balance could be determined within the following ranges (determined by trial and error);  $k_4 \pm 0.1 \text{ sec}^{-1}$ ,  $\alpha_X \pm 0.01$ ,  $k_3X$  was determined to within 10%.

## RESULTS

Figs. 2 and 3 illustrate typical experimental tests of the model. During treatment with chemicals such as 14465 or QX-222 (25) the end plate current consisted of an initial transient of brief duration and a prolonged component (Fig. 2 d). The initial transient was always briefer than the end plate current during treatment with d-TC or high magnesium (Fig. 2 F). The same early brief component characteristic of the effects of all Xylocaine derivatives is seen in Fig. 3 (A-C), recorded during treatment with Xylocaine, but the current monitor at the sensitivity used does not clearly show the low amplitude

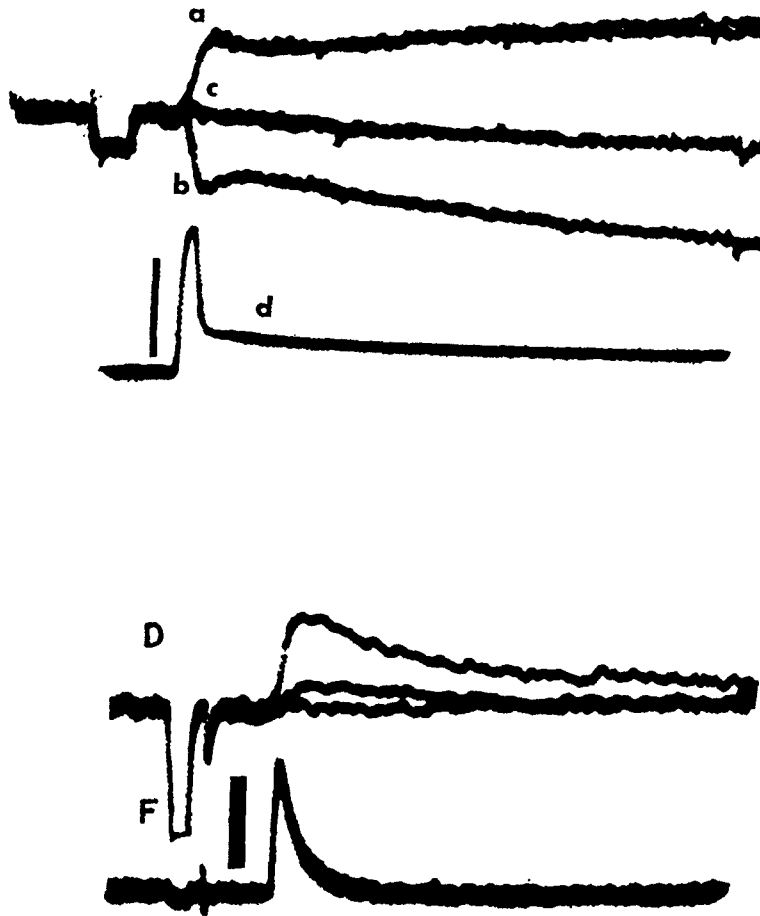

FIGURE 2. Use of the muscle membrane as a null detector to directly compare the output of the computer model and the physiological end-plate current. The figures are photographic composites, recorded from two fibers. Upper, during treatment with about 1.8 mM chemical 14465, (a) = physiological end plate potential; (b) = artificial end plate potential produced by the current shown in (d); (c) resultant of computer-generated and physiological currents together, illustrating the balance that may be obtained. Calibration pulse, 1 msec, 1 mv; current calibration  $4 \times 10^{-9}$  amp. Lower, during treatment with about 0.01 mM d-TC, (D) two traces of potential evoked by nerve stimulation with the simultaneous injection of computer-generated current shown in (F) and one trace without current injection. Calibration pulse, 1 msec, 1 mv; current calibration  $6 \times 10^{-9}$  amp. Note the difference in time scale in lower and upper figures.

prolonged component of the injected current. In this test, during treatment with d-TC or high magnesium ion,  $k_3X$  and  $\alpha_X$  were 0, whereas during treatment with Xylocaine,  $k_3X$  was  $5 \times 10^3 \text{ sec}^{-1}$  and  $\alpha_X$  was 0.05. In seven experiments, each involving tests with at least two Xylocaine derivatives and d-TC or high magnesium ion, it was always possible to balance physiological end plate currents with the previously stated fixed values of  $k_1R$  and  $k_{-1}$  and with

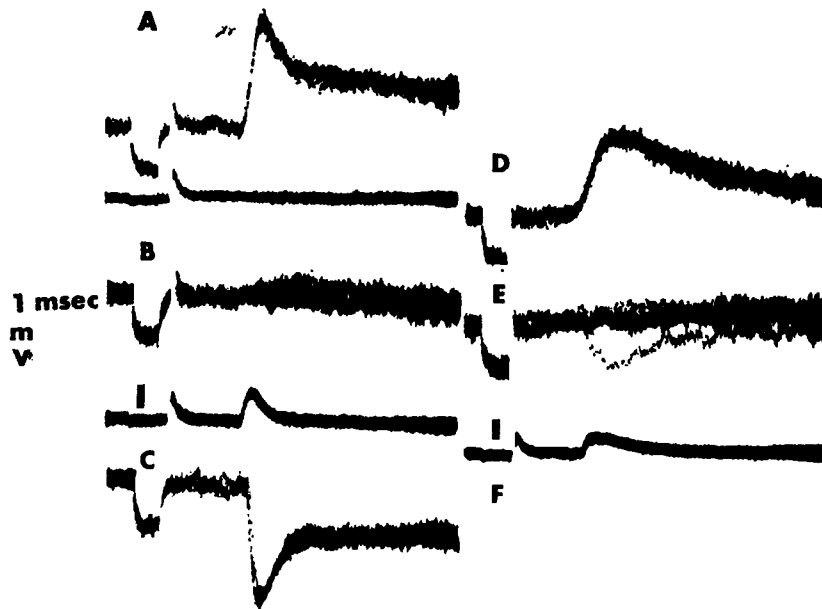

FIGURE 3. Experiment similar to that shown in Fig. 2 using EDL IV, resting potential  $-82$  mv. Each trace consists of three or more responses photographically superimposed. A-C, preparation treated with  $0.35$  mM Xylocaine. A, physiological e.p.p., trace below A monitors current and shows only the nerve stimulus artifact. C, artificial e.p.p. produced by current shown in trace below B, in the absence of nerve stimulation. B, balance achieved with injected current and physiological currents applied together, trace below B showing both injected current and nerve stimulus artifact. D-F, similar experiment in the same preparation treated with  $8.0$  mM magnesium ion. Quantal variations of the response led to the negative-going trace in E. The injected current is shown in F. Note that the current is of long duration compared with the large early phase of that in the trace below B. Calibration pulses  $1$  mv,  $1$  msec; current calibration bars,  $5 \times 10^{-9}$  amp.

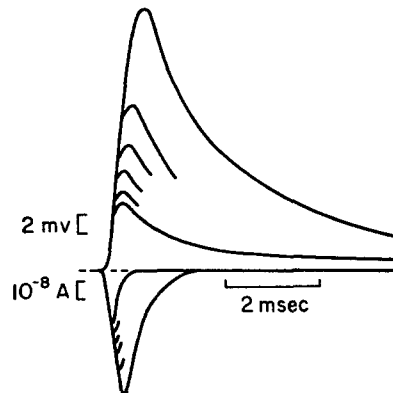

FIGURE 4. Tracings of artificial end plate potentials (upper traces) produced by computer-generated currents (lower traces) applied across the membrane of EDL IV in the absence of nerve stimulation and chemical treatment. The falling phases of most waveforms have been omitted for clarity. The parameter  $k_3X$  was increased from  $0$  to  $10^4$  with  $\alpha_X = 0$  to produce the series.



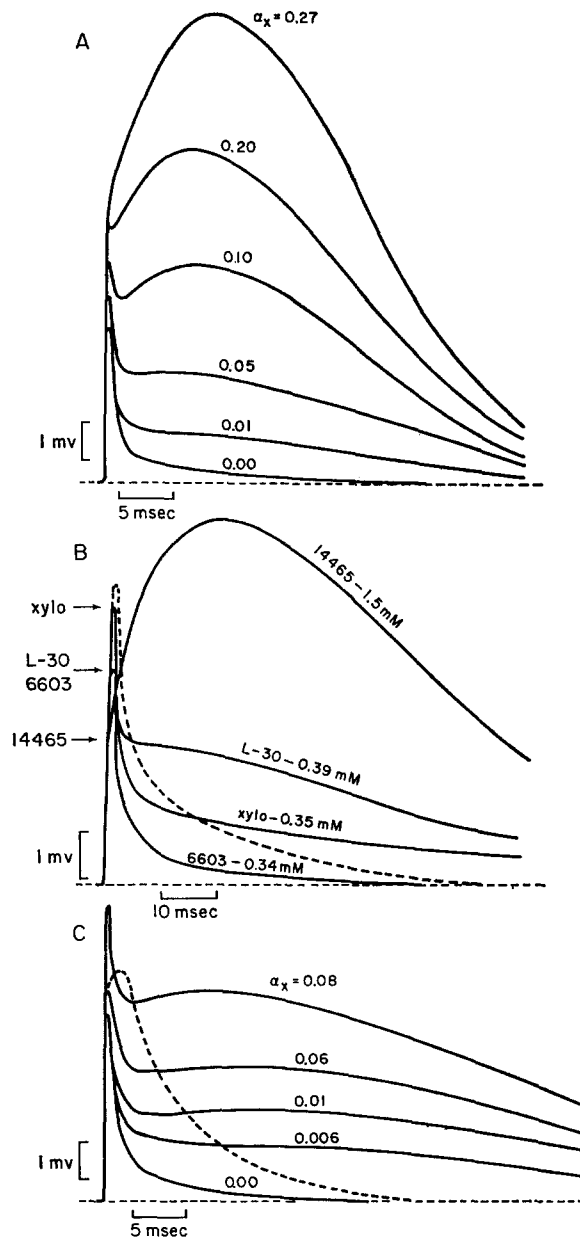

FIGURE 5. Comparison of responses of EDL IV fiber to computer-generated currents and to nerve stimulation in the presence of Xylocaine or one of its analogues. A, responses to computer-generated currents;  $k_2X = 5 \times 10^8 \text{ sec}^{-1}$ ,  $k_4 = 40 \text{ sec}^{-1}$ ,  $\alpha_X$  as indicated. C, same preparation,  $k_2X = 5 \times 10^8 \text{ sec}^{-1}$ ,  $k_4 = 7 \text{ sec}^{-1}$  except for dotted line trace, produced by reducing  $f(\text{rel})$  in amplitude and setting  $k_2X = 0$  to simulate effects of d-TC. The value of  $\alpha_X$  indicated as 0.06 was probably misread, and ought to be about 0.03. B, responses of a different fiber to nerve stimulation in the presence of various chemicals (as noted; dotted trace, response in the presence of d-TC, 0.005 mM). Please note the difference in time scale in A and C and in B.

a fixed time course of  $f(\text{rel})$ , making changes only in  $k_3X$ ,  $k_4$ , and  $\alpha_x$ . In any one experiment, the optimal value of  $k_3$  was constant. The value of  $\alpha_x$  varied from an extreme of 0 (in the case of treatment with QX-314 and similar chemicals) to about 0.3 (during treatment with chemicals 14465 or QX-222).

[Analysis of Fig. 2(a-d) shows that currents that decline continuously (monotonically) after an early transient can produce potential changes that have a minimum between the early transient and the prolonged component. This somewhat surprising relation between current and potential change reflects the normal complexity of skeletal muscle structure, and can be accounted for by the electrically equivalent model for muscle membrane introduced by Falk and Fatt (12, 24). Xylocaine and its derivatives do not affect the passive impedance of muscle at the concentrations used here, and the same relations are found in chemically untreated muscles stimulated by applied current (Fig. 6).]

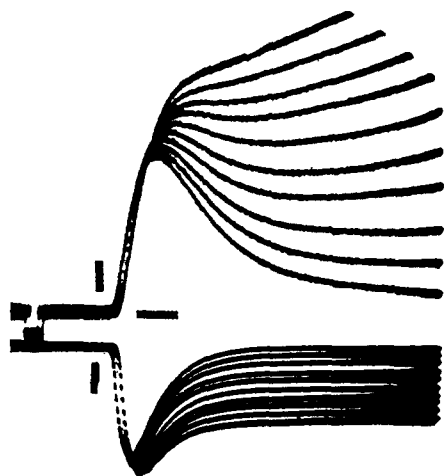

FIGURE 6. Response of EDL IV fiber to a series of transmembrane computer-generated currents in the absence of nerve stimulation or chemical treatment. The potentials (upper traces) were produced by increasing  $\alpha_x$  with  $k_3X$  set to  $5 \times 10^3 \text{ sec}^{-1}$ ; the increase in the prolonged component of current as a result is clearly seen in the lower traces. Calibrations, 2mv, 1 msec,  $1 \times 10^{-9}$  amp. Reprinted from *Nature* (Steinbach, A. B. 1967. 216:1331).

One can obtain a good qualitative picture of the capabilities of the kinetic scheme by examining the potential changes produced in muscle fibers by a series of injected currents in the absence of drug treatment or nerve stimulation (Figs. 4-6). In these cases, positive current was passed outwards through the membrane.

With  $\alpha_x$  set to zero, the output of the model was changed by increasing  $k_3X$  from 0 to  $10^4 \text{ sec}^{-1}$ . This change produced a decrease in amplitude and an increased rate of early fall of the output, with no significant change in the absolute rate of rise of either the output or the response of the muscle (Fig. 4). At the maximum value of  $k_3X$ , the peak amplitude of the potential change was about 25% of its initial amplitude.

An increase in  $\alpha_x$  for a fixed value of  $k_3X$  increased the amplitude of the prolonged component of current and of potential (Figs. 5 and 6). Fig. 5 shows

that the range of potential changes produced covers the range of e.p.p.'s produced by treatment with Xylocaine derivatives. Also, comparison of Fig. 5 A and 5 C shows that the time to prolonged peak and the duration of the prolonged component depend on the value of  $k_4$ .

When long inputs (corresponding to the pulses of ACh released iontophoretically from a pipette) were used with the computer, the output, as a function of  $k_3X$  and  $\alpha_X$  (Fig. 7), was qualitatively different from the output of the computer in response to a brief pulse simulating the release of ACh from the nerve terminal. For  $\alpha_X = 0$ , increasing  $k_3X$  decreases the amplitude of the

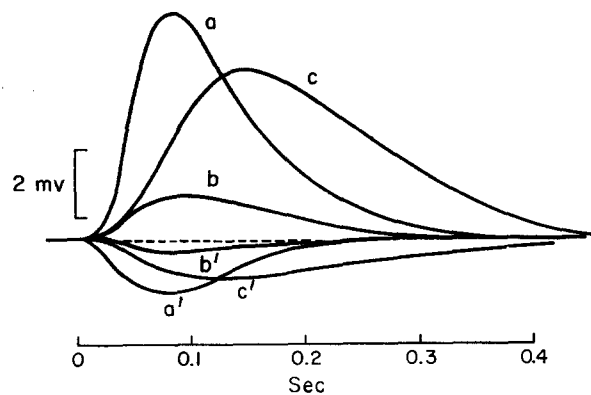

FIGURE 7. Responses of the muscle fiber (EDL IV) to computer-generated currents (lower traces) in the case of a long input pulse to the computer. These responses were intended to simulate the response of the muscle end plate to iontophoretically applied pulses of ACh. *a, a'*, response of the muscle (upper trace) to current (lower trace) with  $k_3X = 0$  and  $\alpha_X = 0$ . *b, b'*, response when  $k_3X = 5 \times 10^8 \text{ sec}^{-1}$  and  $\alpha_X = 0$ . *c, c'*, response with same values of  $k_3X$  but  $\alpha_X = 0.01$ . The tracings shown in this figure should be compared with those of Fig. 8 in reference 25.

response and does not greatly change its time course. For  $0 < \alpha_X \leq 0.01$ , increasing  $k_3X$  produces a decrease in amplitude, and an increase in the time to peak and over-all duration of the response (see reference 25, Fig. 8). For larger values of  $\alpha_X$ , the response is increased in amplitude and prolonged. This computer simulation applies only to effects on iontophoretically evoked responses during the bath application of drugs.

#### DISCUSSION

Using the computer programmed according to the scheme, one can produce currents that are the equal of end plate currents evoked by nerve stimulation during treatment with Xylocaine and its derivatives. This was shown by direct tests of the model using the muscle membrane as a null detector. Qualitatively, the same model can reproduce the range of effects of Xylocaine derivatives on the response to iontophoretically applied ACh. It is now clear that while

Xylocaine derivatives appear to have different effects on the e.p.p. and on the iontophoretically evoked response (25) because of the different durations of the ACh pulses involved, in fact the basic action of the chemicals in the two cases may well be the same. Considering the results of all tests, it is appropriate to discuss the values of the parameters of the kinetic scheme and their meaning.

The estimated value range of  $\alpha_x$ , based on tests involving the e.p.p., was 0 to 0.3. If the model included all actions of Xylocaine and its derivatives, the computer output with  $\alpha_x$  set to 0.3 should quantitatively duplicate the effects of the Xylocaine derivatives 14465 and QX-222 on the iontophoretically evoked response. Experimentally, values of  $\alpha_x$  in excess of 0.01 (roughly that characterizing Xylocaine) did not produce such quantitative agreement; that is, they produced an increase in the response amplitude, which was rarely seen physiologically (25).

This discrepancy might be the result of a purely inhibitory d-TC-like action of the drugs at the relatively high concentrations used in testing effects on the iontophoretically evoked response. If the drugs do have some d-TC-like activity, which is quite possible in view of their molecular structures, the estimate of  $\alpha_x$  obtained from studies of the e.p.p. is probably the more correct one. However, an error in the value of  $k_1R$  (and thus in the values of  $k_{-1}$  and  $k_3X$ , see following discussion) might also produce an error in the determination of  $\alpha_x$ . If the rate coefficients governing the forward reactions between ACh and  $R$ , and ACh- $R$  and  $X$  were underestimated, the range of values of  $\alpha_x$  determined would have been overestimated. This would not greatly affect the response of the model to simulated brief pulses of ACh, but would become evident in tests with longer pulses, when the formation of ACh- $R$ - $X$  goes on for a longer time.

In the scheme tested, the value of  $k_1R$  was  $10^4 \text{ sec}^{-1}$ . Lower values did not suffice but the value actually used was simply the maximum value permitted by the computer for real-time operation. Therefore, although  $k_1R$  must be at least  $10^4 \text{ sec}^{-1}$ , it might be larger. To obtain an estimate of the maximum value, consider that the scheme must be capable of reproducing the effects of Xylocaine on the early component of the e.p.p., and that these effects are not observed when the input to the computer was made about 10 to 100 times as long as the pulse designed to simulate the release of ACh from the nerve (compare the durations of computer outputs in Figs. 4 and 7). Thus, within the context of the model, it appears that  $k_1R$  could not be more than 10-100 times the value actually tested; i.e., not greater than  $10^5$ - $10^6 \text{ sec}^{-1}$ . The value of  $k_{-1}$  was set, relative to  $k_1R$ , to optimize the computer output.

In order to produce the characteristic effects of Xylocaine on the e.p.p., the value of  $k_3X$  must be allowed to attain a value at least as large as  $k_{-1}$ . If it were not, the conversion of ACh- $R$  to ACh- $R$ - $X$  would not take place

to a significant extent. However,  $k_3X$  need be no larger than  $k_1R$ ; if it were, the rate of rise of the e.p.p. would be significantly reduced. The value of  $k_3X$  used in tests was between 5 and  $10 \times 10^8 \text{ sec}^{-1}$ , and the exact value depended in each case on the concentration of Xylocaine or derivative in the solution bathing the preparation (normally 0.2–1.5 mM).

It would be desirable to compare the response of the model to a steady input and the response of the end plate to a steady concentration of ACh in the presence of Xylocaine. However, ACh in steady concentrations produces desensitization of the receptors (18, 23), and incorporation of this phenomenon would have made the model unjustifiably complex. Because the tests of the model involved only responses to transient inputs,  $R$ , the effective concentration of receptors, cannot be calculated from  $k_1R$  and  $k_{-1}$  although reasonable estimates of the value of the dissociation constant of the ACh- $R$  complex ( $K_d = k_{-1}/k_1$ ) might be made.

For any given muscle preparation tested, the value of  $k_4$  did not have to be adjusted during the successive applications of several Xylocaine derivatives. This suggests that the stability of the ACh- $R$ - $X$  complex is about the same regardless of the Xylocaine derivative involved. In the seven preparations examined, the optimum value of  $k_4$  varied from about 5 to  $20 \text{ sec}^{-1}$ . This low range validates one of the original postulates of the scheme; that the ACh- $R$ - $X$  complex must be relatively stable in order to produce the prolonged current. It also appears that the assumption that  $k_{-4}$  is negligible is justified, although such a back reaction to form ACh- $R$ - $X$  would be very difficult to detect, due to the rapid removal of the transmitter by diffusion and hydrolysis. The variation in  $k_4$  from preparation to preparation is similar to the variation in other effects of the chemicals that can be observed directly (25) and may well reflect a variation in the properties of receptor populations.

The actions of Xylocaine and its derivatives, and also of procaine (22) are clearly more complex than the action of d-TC (25). According to the hypothesis presented here, this difference can be attributed to two main differences in the level of molecular interactions between drug and receptors. (a) d-TC has a high affinity for receptors and forms complexes with receptors in the absence of ACh (7, 15). Xylocaine and its derivatives have a low affinity for receptors in the absence of ACh, but have a high affinity for at least some receptors after the receptors have been activated by ACh. (b) The d-TC-receptor complex is relatively stable but completely inactive. The complex formed when Xylocaine (or a derivative) reacts with a receptor after it has been activated by ACh is also stable, but may have some activity (less than 0.3 that of the ACh- $R$  complex) depending upon the structure of the drug used.

In formulating the kinetic model, it was assumed that the increase in membrane ionic permeability producing the end plate current is relatively

nonselective (5, 27, 29). This implicit assumption created no difficulties in tests of the model; that is, it was not necessary to consider the possibility of ion-selective changes in permeability during receptor activation in the presence of the drugs tested, including procaine. Maeno (22) deduced that a selective decrease in  $\Delta g_{Na}$  (the increase in conductance for the sodium ion

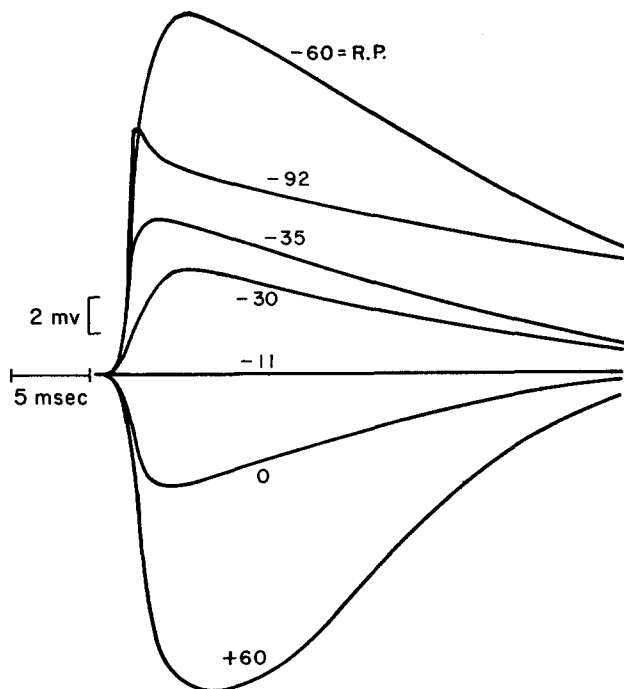

FIGURE 8. Effect of a change in membrane potential (produced by passing a steady current through the second micropipette) on the time course of the e.p.p. in EDL IV during treatment with chemical 14465. Electrical excitability and contraction were eliminated by allowing the negative capacity amplifier connected to the recording microelectrode to oscillate—this treatment did not alter the e.p.p. The tracings have been brought to a common base line to permit visual comparison; the numbers indicate the membrane potential before stimulation. The anomalous effect of hyperpolarization (from  $-60$  mv to  $-92$  mv) also occurs for potentials evoked by injected currents, and can be attributed to changes in the impedance of the muscle membrane that occur with hyperpolarization (1). There is no indication that the reversal potential for the prolonged component is different from that of the early component (see text).

produced by receptor activation) occurred during the early brief component of the e.p.p. during treatment with procaine, and that this was superseded by a prolonged residual sodium current during the prolonged component. From this conclusion one would expect that the reversal potentials of the two phases (early and prolonged) of the e.p.p. during treatment with procaine (or Xylocaine) would be different. However, in slightly damaged prepara-

tions where it was possible to shift the muscle fiber membrane potential beyond zero, the entire e.p.p. reversed at  $-5$  to  $-15$  mv during treatment with procaine or Xylocaine derivatives (Fig. 8). Although such tests might not have revealed slight changes in the reversal potential of the early component of the e.p.p., they strongly suggest that the prolonged component of the end plate current is not carried by sodium ions alone.

Thus it was not possible to confirm that the action of Xylocaine and procaine involves any selective effect on receptors that might control membrane permeability for only one ion. The complex change in the e.p.p. produced by Xylocaine derivatives (and to a lesser degree, by procaine) can be understood in terms of relatively simple changes in the end plate current provided that adequate account is taken of the complexity of the passive impedance of muscle membrane (12, 24). The equivalent circuit used by Maeno (22) was not adequate in this respect, since the muscle membrane was represented only by a resistance in parallel with a capacitance.

The nature of the proposed ACh-R-X complex cannot be determined unambiguously from the kinetic scheme presented. Perhaps the most reasonable hypothesis is that ACh and X are bound to separate sites on the same or adjacent molecules in such a manner, that binding to one site influences the properties of the other. Both of these sites are ACh receptor sites, but the binding of ACh to one changes the specificity of the other so that its affinity for Xylocaine is greatly increased. The stability of the resulting complex might result from the presence of the terminal ring in Xylocaine; preliminary results indicate that Xylocaine derivatives lacking the ring do not produce prolongations of the e.p.p. and have little effect on the time course of the early brief component. But although a detailed molecular model cannot be constructed from the present data, one postulate for the construction of such a model is strongly suggested, namely, that the effects of Xylocaine occur because of changes in receptor structure produced by the action of ACh. Such change in receptor structure might reasonably be involved in the transduction of chemical binding to membrane ionic permeability change.

## APPENDIX 1

### *Implementation of the Kinetic Scheme*

A Donner model 3500 electronic analogue computer was used to solve the differential equations describing the kinetic scheme. The mode of operation of such computers is discussed in standard textbooks, e.g. (19). Referring to the diagram of circuit 1 below, consider the triangle labeled (2). The triangle denotes a high open-loop gain inverting amplifier. Imagine that the only components connected around the amplifier are  $R_1$ ,  $C_1$ , and  $R_2$ .  $V_{ACh}$  is the voltage at the input, and  $V_{ACh-R}$  that at the output. The amplifier keeps the voltage at the input *node* (marked with a solid circle) at essentially ground potential, and by applying Kirchoff's laws to that node (imagining that only





1:4v (for node 5)

$$\frac{dV_{X-R}}{dt} = - \frac{xgV_{ACh-R}}{R_7C_2} - \frac{V_{X-R}}{R_8C_2}$$

1:5

$\frac{d[R]}{dt} = 0$  by assumption.  $R$  is not represented by a voltage but is included in the effective rate coefficient,  $k_1R$ .

1:6

$\frac{d[X]}{dt} = 0$  by assumption.  $X$  is not represented by a voltage but is included in the effective rate coefficient,  $k_3X$ .

All the relevant parameters of the kinetic equations correspond to values of resistances and capacitances in the nodal equations, as summarized below:

<i>Parameter</i>	<i>Corresponding value in computer</i>
$f(\text{rel})$	$V_{f(\text{rel})}/R_1C_1$
[ACh]	$-V_{ACh}$
[ACh-R]	$-V_{ACh-R}$
[ACh-R-X]	$-V_{X-R}$
$k_1R$	$1/R_2C_1$
$k_{-1}$	$1/R_4C_1$
$k_d$	$1/R_6C_1$
$k_3X$	$xg/R_9C_1 = xg/R_7C_2$
$k_4$	$1/R_8C_2$

$[0 \leq X \leq 1, \text{ set by adjusting } R_X ; g = (R_{11}/R_{10})(R_{13}/R_{12})]$

It is necessary to satisfy the output relationship of equation 5 in the text. The voltage divider  $R\alpha_X$  (where  $0 \leq \alpha_X \leq 1$ ) was used in order to establish a variable relative activity for the various Xylocaine derivatives. When an inverting amplifier of unity gain was used to reverse the sign of  $V_{X-R}$ , the two voltages  $V_{ACh-R}$  and  $(V_{X-R})\alpha_X$  were summed by another inverting amplifier of unity gain to produce the output,  $V_{\text{out}}$ . Thus:

(5) (from text)

$$I_{\text{end plate}} = \alpha[\text{ACh-R}] + \alpha_X[\text{ACh-R-X}]$$

1:7

$$-V_{\text{out}} = V_{ACh-R} + \alpha_X(V_{X-R})$$

It happens that for a positive  $V_{f(\text{rel})}$  the output is a negative voltage. As discussed

in the text,  $\alpha$  is assumed to be unity; thus the correspondence between voltage in the model and concentration in the kinetic scheme is one-to-one. The voltage  $V_{f(\text{rel})}$  was formed by filtering a brief pulse from a Tektronix 161 pulse generator through a variable network of resistors and capacitors, and was adjusted empirically to correspond to the suspected time course of  $f(\text{rel})$ . This was estimated from previous studies (11, 6), taking into account the known time course of the end plate current (28) and estimates of rates of diffusion of ACh liberated from the terminal (11). The values of components governing  $k_d$  were chosen to produce a time course of  $V_{\text{ACh-R}}$  corresponding to the experimentally determined end plate current (see reference 28).

*Note Added in Proof* A recent paper (Gage, P. W., and C. M. Armstrong. 1968. *Nature*. **218**:363) studies the change in the duration of the miniature end plate current as a function of membrane potential and suggests that ACh opens separate channels for potassium and for sodium ions. The effect studied might also result from a direct effect of membrane potential on the time course of activation of a nonion-selective receptor. Changes in the light scattering and birefringence of nerve cell membranes as a result of changes in membrane potential have recently been demonstrated (Cohn, L. B., R. D. Keynes, and B. Hille. 1968. *Nature*. **218**:438).

*Received for publication 12 December 1967.*

#### BIBLIOGRAPHY

1. ADRIAN, R. H., and W. H. FREYGANG, JR. 1962. Potassium conductance of frog muscle membrane under controlled voltage. *J. Physiol. (London)*. **163**: 104.
2. ARIENS, E. J. 1964. *Molecular Pharmacology: The Mode of Action of Biologically Active Compounds*. Academic Press, Inc., New York.
3. BIRKS, R., H. E. HUXLEY, and B. KATZ. 1960. The fine structure of the neuromuscular junction of the frog. *J. Physiol. (London)*. **150**: 134.
4. CASTILLO, J. DEL, and B. KATZ. 1954. The effect of magnesium on the activity of motor nerve endings. *J. Physiol. (London)*. **124**: 553.
5. CASTILLO, J. DEL, and B. KATZ. 1954. The membrane change produced by neuromuscular transmitter. *J. Physiol. (London)*. **125**: 546.
6. CASTILLO, J. DEL, and B. KATZ. 1954. Electrophoretic application of acetylcholine to the two sides of the endplate membrane. *J. Physiol. (London)*. **125**: 16P.
7. CASTILLO, J. DEL, and B. KATZ. 1957. A study of curare action with an electrical micro-method. *Proc. Roy. Soc. (London) Ser. B*. **146**: 362.
8. CASTILLO, J. DEL, and B. KATZ. 1957. A comparison of acetylcholine and stable depolarizing agents. *Proc. Roy. Soc. (London) Ser. B*. **146**: 362.
9. CASTILLO, J. DEL, and B. KATZ. 1957. Interaction at endplate receptors between different choline derivatives. *Proc. Roy. Soc. (London) Ser. B*. **146**: 369.
10. DALE, H. W., W. FELDBERG, and M. VOGT. 1936. Release of acetylcholine at voluntary motor nerve endings. *J. Physiol. (London)*. **86**: 353.
11. ECCLES, J. C., and J. C. JAEGER. 1958. The relationship between the mode of operation and the dimensions of the junctional region at synapse and motor endplate. *Proc. Roy. Soc. (London) Ser. B*. **148**: 38.
12. FALK, G., and P. FATT. 1964. Linear electrical properties of striated muscle fibers observed with intracellular electrodes. *Proc. Roy. Soc. (London) Ser. B*. **160**: 69.
13. FATT, P., and B. KATZ. 1951. An analysis of the endplate potential recorded with an intracellular electrode. *J. Physiol. (London)*. **115**: 320.

14. HUBBARD, J. I., and R. F. SCHMIDT. 1963. An electrophysiological investigation of mammalian motor nerve terminals. *J. Physiol. (London)*, **166**: 145.
15. JENKINSON, D. H. 1960. The antagonism between d-tubocurarine and substances which depolarize the motor endplate. *J. Physiol. (London)*. **152**: 309.
16. KATZ, B., and R. MILEDI. 1965. The measurement of synaptic delay, and the time course of acetylcholine release at the neuromuscular junction. *Proc. Roy. Soc. (London) Ser. B.* **161**: 483.
17. KATZ, B., and R. MILEDI. 1965. The effect of temperature on the synaptic delay at the neuromuscular junction. *J. Physiol. (London)*. **181**: 656.
18. KATZ, B., and S. THESLEFF. 1957. A study of the 'desensitization' produced by acetylcholine at the motor endplate. *J. Physiol. (London)* **138**: 63.
19. KORN, G. A., and T. M. KORN. 1964. Electronic analog and hybrid computers. McGraw-Hill Book Company, New York.
20. KRNJEVIC, K., and R. MILEDI. 1958. Acetylcholine in mammalian neuromuscular transmission. *Nature*. **182**: 805.
21. KRNJEVIC, K., and J. F. MITCHELL. 1960. Release of acetylcholine in rat diaphragm. *Nature*. **186**: 241.
22. MAENO, T. 1966. Analysis of sodium and potassium conductances in the procaine endplate potential. *J. Physiol. (London)*. **183**: 592.
23. MANTHEY, A. A. 1966. The effect of calcium on the desensitization of membrane receptors at the neuromuscular junction. *J. Gen. Physiol.* **49**: 963.
24. STEINBACH, A. B. 1967. Unusual endplate potentials which reflect the complexity of muscle structure. *Nature*. **216**: 1331.
25. STEINBACH, A. B. 1968. Changes in the time course of the end plate potential produced by Xylocaine (lidocaine) and its derivatives. *J. Gen. Physiol.* **52**: 144.
26. TAKEUCHI, N. 1958. The effect of temperature on the neuromuscular junction of the frog. *Japan. J. Physiol.* **8**: 391.
27. TAKEUCHI, N. 1963. Some properties of the conductance change at the endplate membrane during the action of acetylcholine. *J. Physiol. (London)*. **167**: 128.
28. TAKEUCHI, A., and N. TAKEUCHI. 1959. Active phase of the frog's endplate potential. *J. Neurophysiol.* **22**: 395.
29. TAKEUCHI, A., and N. TAKEUCHI. 1960. On the permeability of the endplate membrane during the action of transmitter. *J. Physiol. (London)*. **154**: 52.
30. WASER, P. G. 1960. The cholinergic receptor. *J. Pharm. Pharmacol.* **12**: 577.