

Radioassay for Hydrogenase Activity in Viable Cells and Documentation of Aerobic Hydrogen-Consuming Bacteria Living in Extreme Environments

BERNHARD SCHINK,† F. S. LUPTON, AND J. G. ZEIKUS*

Department of Bacteriology, University of Wisconsin-Madison, Madison, Wisconsin 53706

Received 9 July 1982/Accepted 25 February 1983

An isotopic tracer assay based on the hydrogenase-dependent formation of tritiated water from tritium gas was developed for in life analysis of microbial hydrogen transformation. This method allowed detection of bacterial hydrogen metabolism in pure cultures or in natural samples obtained from aquatic ecosystems. A differentiation between chemical-biological and aerobic-anaerobic hydrogen metabolism was established by variation of the experimental incubation temperature or by addition of selective inhibitors. Hydrogenase activity was shown to be proportional to the consumption or production of hydrogen by cultures of *Desulfovibrio vulgaris*, *Clostridium pasteurianum*, and *Methanosarcina barkeri*. This method was applied, in connection with measurements of free hydrogen and most-probable-number enumerations, in aerobic natural source waters to establish the activity and document the ecology of hydrogen-consuming bacteria in extreme acid, thermal, or saline environments. The utility of the assay is based in part on the ability to quantify bacterial hydrogen transformation at natural hydrogen partial pressures, without the use of artificial electron acceptors.

Gaseous hydrogen plays an important role as an intermediary metabolite during microbial transformation of organic matter (12). Hydrogen is produced as a catabolic end product by a variety of anaerobic bacteria (9) or as a byproduct of the nitrogenase reaction by nitrogen-fixing bacteria (7). Other microorganisms use hydrogen as an electron donor in both catabolic and anabolic redox processes. Anaerobically, hydrogen oxidation is coupled to CO₂ reduction by methanogens and acidogens (30, 31) and to sulfate reduction by sulfidogenic bacteria (17, 18). Aerobically, the knallgas or hydrogen bacteria also use hydrogen gas for both energy conservation and autotrophic CO₂ fixation (4). Phototrophic bacteria can either produce or consume molecular hydrogen (16). Thus, bacterial hydrogen metabolism has been studied intensively in laboratory cultures.

Ecological understanding of bacterial hydrogen metabolism in nature remains rather limited. The limited amounts of hydrogen that reach atmospheric air or waters which overlay anaerobic microbial niches have been quantified (5, 24). However, vast amounts of hydrogen are transferred between different organisms during anaerobic degradation of organic matter (30).

The concentration of hydrogen in anoxic aquatic sediments (25, 27, 29) is very low and usually below the detection limits of conventional gas chromatographic methods (i.e., 0.1 μl/ml or 5 μmol/liter).

The present paper presents a first approach to an understanding of hydrogen-transforming reactions by bacterial cells, namely, the development of a practical assay system for in life (i.e., in living cells as opposed to nonviable cells or cell extracts) measurement of bacterial hydrogenase. Assays of hydrogenase activity usually employ artificial acceptors and high H₂ partial pressures (1). These conditions can alter the redox state of the system and thus present an inaccurate measurement of the actual hydrogenase activity in vivo. Measurements of hydrogenase activity by the exchange of ³H₂ into ³H₂O have been limited to a few studies of cell enzyme preparations (1). A tritium gas assay was chosen for the present studies to overcome these drawbacks and for ease of detection. The validity of the assay was established with pure cultures of aerobic and anaerobic hydrogen-transforming (i.e., consuming, producing, or both) bacteria, and with natural samples obtained from aerobic aquatic ecosystems where extreme environmental parameters (i.e., temperature, salt, or protons) account for the accumulation of free hydrogen in situ.

† Present address: Fakultät für Biologie, Universität Konstanz, Postfach 5560, D-7750 Konstanz, West Germany.

MATERIALS AND METHODS

Chemicals. All chemicals used were of reagent grade and were obtained from Sigma Chemical Co. (St. Louis, Mo.) or Mallinckrodt (Paris, Ky.). All gases used were obtained from Matheson Scientific (Joliet, Ill.). Tritium gas was a gift of Paul De Luca, University of Wisconsin, Madison.

Bacterial strains and growth conditions. Two knall-gas bacteria were used: *Alcaligenes eutrophus* H16 (DSM 428, ATCC 17699), and an unidentified, gram-negative hydrogen bacterium isolated from lake sediment, strain KMHW. These strains were grown autotrophically on a mineral salts medium (medium 81, catalog of the Deutsche Sammlung von Mikroorganismen, Göttingen, West Germany), which contained, in grams per liter of distilled water: KH_2PO_4 , 2.3; $\text{Na}_2\text{HPO}_4 \cdot 2\text{H}_2\text{O}$, 2.9; NH_4Cl , 1; $\text{MgSO}_4 \cdot 7\text{H}_2\text{O}$, 0.5; $\text{CaCl}_2 \cdot 2\text{H}_2\text{O}$, 0.01; and ferrous ammonium citrate, 0.05. The gas atmosphere was 40% H_2 -40% N_2 -10% O_2 -10% CO_2 . *Methanosarcina barkeri* neotype strain MS was grown in phosphate-buffered mineral medium (PBB medium), previously described (26), with 100 mM methanol. *Clostridium pasteurianum* W5 was obtained from the University of Wisconsin Culture Collection and was grown in PBB medium containing 25 mM glucose as carbon source. *Desulfovibrio vulgaris* Madison was grown in a phosphate buffer medium with lactate (100 mM) and sulfate (140 mM) as energy source (3). Three bacterial strains that did not contain H_2 -transformation activity were used as controls: *Micrococcus luteus*, *Pseudomonas aeruginosa*, and *Pseudomonas fluorescens*. These bacteria were obtained from the University of Wisconsin Culture Collection and were grown aerobically on Nutrient Broth (Difco Laboratories, Detroit, Mich.).

Hydrogenase assay. The tritium preparation used contained 72% $^3\text{H}_2$ and 28% H_2 diluted in cold hydrogen gas with a specific activity of 25.75 ± 0.25 $\mu\text{Ci/ml}$ at ambient atmospheric pressure and was stored at 2 atm (0.0114 kPa) initial pressure in a 500-ml stainless steel gas tank (i.e., a lecture bottle) equipped with a rubber septum at the outlet valve. Gas samples of 5 to 10 ml were transferred by a syringe to the lower pressure tube of the tritium stock gas apparatus illustrated in Fig. 1. This tube was shaken vigorously after tritium gas addition to absorb traces of tritiated water which can form during storage of tritium gas in steel bottles (8). The mercuric chloride solution was used as an absorbent for tritiated water, as an inhibitor of aerobic hydrogen-consuming bacteria, and as a mechanism for maintenance of constant pressure after gas removal. For individual experiments, tritiated hydrogen was removed from the sample preparation tube headspace by a gas-tight, 250- μl Hamilton syringe. Tritium gas was stored in the sample preparation tube for up to 2 weeks without detectable loss in radioactivity.

For measurement of hydrogen transformation activity by aerobic hydrogen-oxidizing bacteria in either cell suspensions or natural waters, samples (up to 10 ml) were placed into glass tubes (18 by 142 mm; Bellco Glass, Inc., Vineland, N.J.) sealed with butyl rubber stoppers (no. 1; Scientific Products, Inc., Detroit, Mich.) that contained either an N_2 or air atmosphere. Additions to tubes were performed by syringe transfer techniques. Control experiments contained 100 mM

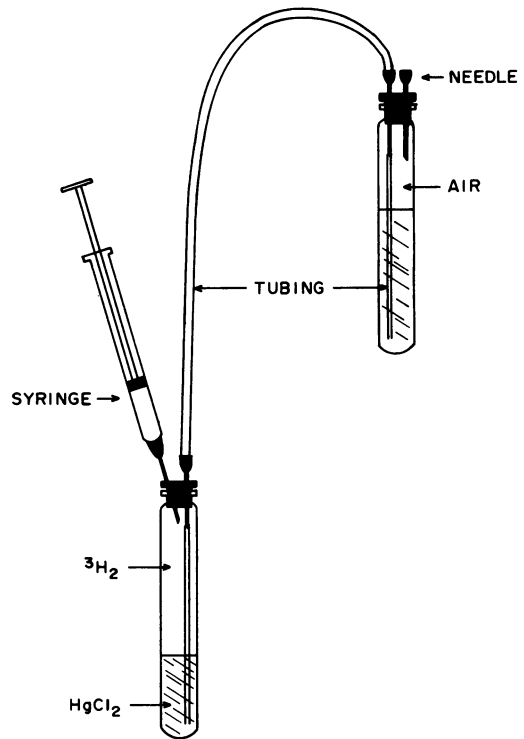

FIG. 1. Apparatus for preparation of a tritium stock gas mixture. $^3\text{H}_2$ was added by 10-ml glass syringe into the lower sample preparation tube, which was completely filled with 100 μM MgCl_2 before tritium addition. Gas addition forced the HgCl_2 solution into the pressure regulation tube.

mercuric chloride to inhibit biological activity. For long-term (i.e., >3 h) incubation experiments with natural samples, chloramphenicol was added to a 50 $\mu\text{g/ml}$ final concentration to prevent induction of hydrogen-metabolizing activities.

The reaction was started by syringe addition of 200 μl of tritium gas (5.15 μCi) to the experimental tubes. Experimental reaction tubes were shaken slowly (~50 strokes per min) at 30°C in the laboratory or incubated at in situ temperature without shaking in the field. Samples were removed periodically from the liquid phase of the reaction mixture by a syringe and centrifuged at $12,000 \times g$ for 10 min, and the supernatant was transferred to vials that contained 10 ml of Aquasol (New England Nuclear Corp., Boston, Mass.) as scintillant. Radioactivity was then measured in a Packard Tri-Carb liquid scintillation counter. The counting efficiency was 54 to 57% as determined with a commercial standard. Quench corrections were made by quench calibration curves on the basis of the channels ratio method. Gaseous tritium was not removed from the liquid samples by boiling or gassing with nitrogen; this was not required for sample preparation because of the low solubility of tritium gas in water (13), and the ratio of $^3\text{H}_2$ to H_2 added was low. Performance of the assay in the field used replicate experimental reaction tubes that were stopped at certain time intervals by addition of 1 ml of 10 N NaOH; sample

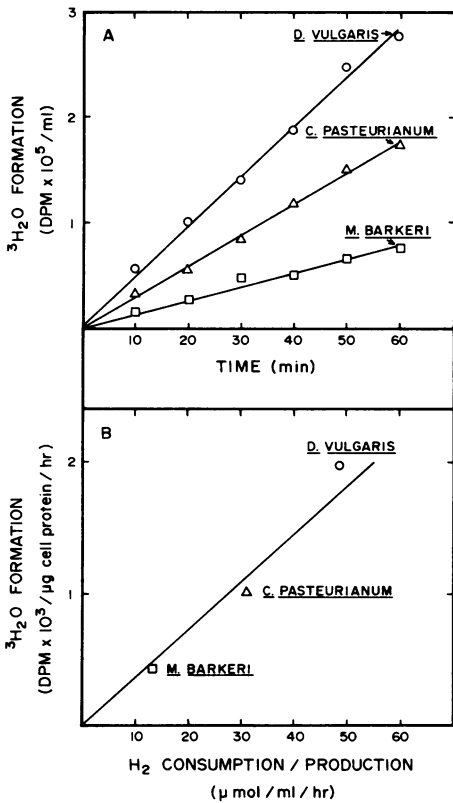

FIG. 2. (A) Comparison of time and hydrogenase activity and (B) the production and utilization of H_2 to the rate of $^3\text{H}_2\text{O}$ formation by anaerobic bacteria. H_2 consumption was measured for *D. vulgaris* and *M. barkeri* and H_2 production was measured for *C. pasteurianum*. Cells were grown to late-exponential phase at 30°C in pressure tubes. Before the assay, the headspace was flushed six times with N_2 gas, and 250 μl of $^3\text{H}_2$ was added. The assays were performed at 27 to 30°C .

preparation for radioactivity was performed after neutralization and ~ 1 to 2 weeks later in the laboratory.

Fastidious anoxic conditions (32) were used to study hydrogenase activity of anaerobes that were grown in pressure tubes which contained 10 ml of medium. To examine $^3\text{H}_2$ transformation activity in cultures of either *D. vulgaris*, *C. pasteurianum*, or *M. barkeri*, the tube headspaces were flushed six times with a N_2 (80%)– CO_2 (20%) gas mixture before the addition of 250 μl of $^3\text{H}_2$. To examine the effect of $^3\text{H}_2$ dilution in H_2 , either 50, 100, 150, 200, or 250 μl of $^3\text{H}_2$ was added to *D. vulgaris* cultures with enough H_2 gas to bring the final volume of hydrogen to 250 μl . These cultures were incubated for 60 min, and $^3\text{H}_2$ transformation rates were determined.

Field sites and physicochemical methods. Two field sites in Yellowstone National Park (Wyoming) were examined: a thermal spring, Washburn Pool B, and an acid spring, Lemonade Pool. Washburn Pool B is located several meters northwest of Devil's Ink Pot in the Washburn Hot Springs area, southwest of Mount

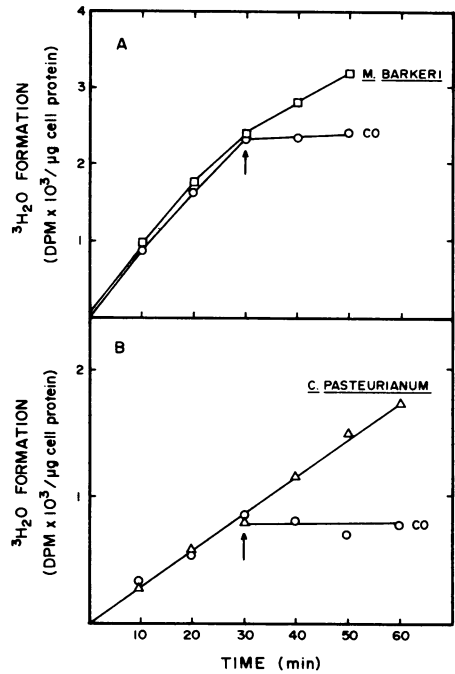

FIG. 3. The effect of carbon monoxide on $^3\text{H}_2$ transformation of (A) *M. barkeri* and (B) *C. pasteurianum* at 27 to 30°C . Arrow represents the time at which carbon monoxide (20%) was added.

Washburn. Springs in this area contain volcanic hydrogen (10, 32). Lemonade Pool is a highly acidic spring in the Obsidian Creek Valley, just downstream from Roaring Mountain. The edge sediments of the spring display a high biological H_2 -generating activity (J. G. Zeikus, unpublished data).

Great Salt Lake (Utah) was selected as a hypersaline environment. Water and sediment were sampled from the deepest part of the lake's South Arm by procedures previously described (29). This site was selected because the sediments actively produce detectable hydrogen, and the overlying waters are stratified year round (T. Phelps and J. G. Zeikus, Abstr. Annu. Meet. Am. Soc. Microbiol. 1980, 14, p. 85).

Water samples were obtained with a peristaltic pump and latex tubing. The tubing was lowered to the appropriate depth, and water was pumped for approximately 1 min before 10 ml of water was withdrawn by syringe and transferred into N_2 -flushed butyl rubber-stoppered vials. Sulfide was determined by titrimetry (2). Water samples were vortexed to strip dissolved gases into the headspace. Methane was determined on a Varian Aerograph with a Porapak R column and flame ionization detectors. Hydrogen was determined on a Packard 419 gas chromatograph with a thermal conductivity detector and N_2 as the carrier gas (15).

Temperature, oxygen, and salinity were measured in situ with a Yellow Springs Instruments combination temperature-oxygen meter, high-temperature thermistor meter, and salinity meter. The hydrogen ion activity was measured with a Corning model 401 portable pH meter. It should be noted that at high salinities, salt

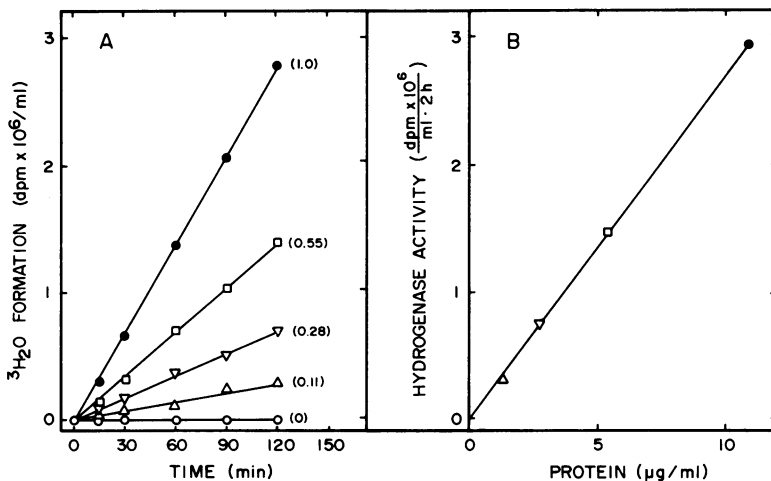

FIG. 4. Dependence of aerobic $^3\text{H}_2\text{O}$ formation kinetics on cell density by suspensions of the hydrogen bacterium strain KMHW. (A) Relation of $^3\text{H}_2$ transformation to time. Numbers in parentheses indicate the micrograms of cell protein per milliliter. (B) Relation of hydrogenase activity to protein. Log-phase cells were grown on $\text{H}_2\text{-CO}_2\text{-O}_2$ and added to sealed tubes that contained potassium phosphate buffer, pH 7.0, on air headspace and 1 ml of tritium gas. The reaction was performed at 30°C with constant shaking.

influences proton activity measurements. The values reported for H^+ activity were made with the electrode standardized with commercial pH 7.0 and 4.0 buffer solutions. The electrode was stored in pH 7.0 buffer before pH measurements.

Cultivation and enumeration techniques. For cultivation and enumeration of aerobic hydrogen-oxidizing bacteria from nature, the autotrophic growth conditions were adapted to approximate in situ environmental parameters. Medium 81 was used directly for thermophilic hydrogen bacteria. This medium was titrated to pH 3.5 with concentrated sulfuric acid for experiments with acidophilic hydrogen-oxidizing bacteria. The growth medium used for halophilic hydrogen bacteria contained, in grams per liter of distilled water: solar salt, 15; NaCl, 90; $\text{MgSO}_4 \cdot 7\text{H}_2\text{O}$, 10; sodium citrate, 3; K_2HPO_4 , 1; $\text{Fe}(\text{NH}_4)_2(\text{SO}_4)_2 \cdot 6\text{H}_2\text{O}$, 0.05; NH_4Cl , 1; and $\text{CaCl}_2 \cdot 2\text{H}_2\text{O}$, 0.01. Each salt was completely dissolved before the next addition. The final pH was ~ 8.0 . Experiments employed butyl rubber stopper-sealed 23-ml Belco pressure tubes that contained 2 ml of autoclaved medium. Before inoculation, the tubes were evacuated to half atmospheric pressure with a syringe, and the gas phase was returned to ambient pressure with a final gas mixture of 40% H_2 -40% N_2 -10% O_2 -10% CO_2 . After inoculation, experimental tubes were incubated at in situ temperatures ($\pm 5^\circ\text{C}$). The three-tube most-probable-number technique was used for enumeration of bacteria in natural samples. The first dilution tubes were inoculated with 0.2 ml of sample and subsequently diluted in 1:10 (vol/vol) steps. Cell numbers were calculated by detection of visible turbidity and by using standard tables (2).

RESULTS

Hydrogen transformation by bacterial cultures.

Figure 2A compares the rate of $^3\text{H}_2$ conversion into $^3\text{H}_2\text{O}$ in cultures of two H_2 -consuming

species (*D. vulgaris* and *M. barkeri*) and a H_2 -producing species (*C. pasteurianum*). Notably, the rate of $^3\text{H}_2$ transformation into $^3\text{H}_2\text{O}$ was directly related to the rate of hydrogen production or consumption by these three species (Fig. 2B). $^3\text{H}_2$ transformation was not displayed by these cultures in the presence of inhibitors that poison obligate anaerobes (i.e., high Formalin, temperature, or oxygen). Thus, it appears that $^3\text{H}_2$ transformation is a measure of hydrogenase activity, but it does not distinguish between the consumption and production kinetics of hydrogenase.

The influence of carbon monoxide on $^3\text{H}_2$ transformation by *M. barkeri* and *C. pasteurianum* was studied because this hydrogenase inhibitor does not kill these anaerobic bacteria (1). Hydrogenase activity is displayed in cultures of *M. barkeri* grown on methanol (26) or *C. pasteurianum* grown on glucose (1). Figure 3 shows that CO addition significantly inhibited $^3\text{H}_2$ transformation activity of both species.

The kinetics of $^3\text{H}_2$ transformation by cell suspensions of the aerobic hydrogen bacterium strain KMHW is shown in Fig. 4. The reaction was linear with time for at least 2 h and displayed a linear dependence of transformation rate on the amount of cell protein. $^3\text{H}_2\text{O}$ production was not detected in controls inhibited with $100 \mu\text{M}$ MgCl_2 . The dependence of $^3\text{H}_2$ transformation by strain KMHW on the gas ratio of the headspace is shown in Fig. 5. Addition of cold hydrogen gas in various amounts to the air-tritium mixture lowered the apparent tritium transformation rates proportional to the increased $\text{H}_2/(\text{H}_2 + ^3\text{H}_2)$ gas ratio, demonstrating

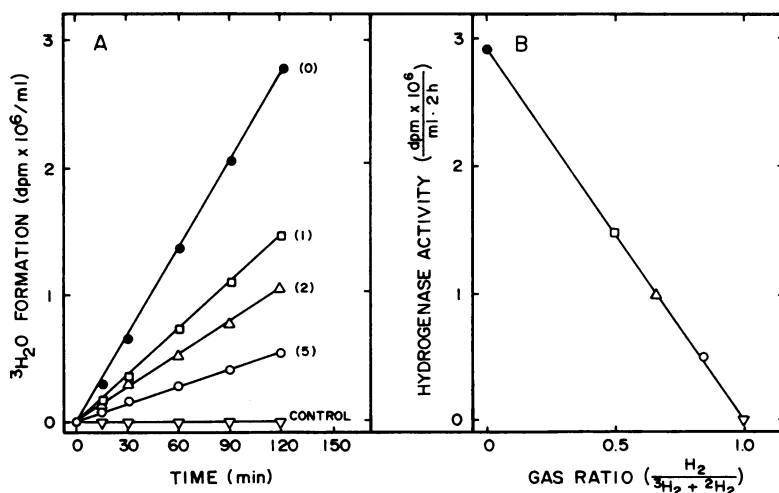

FIG. 5. Dependence of aerobic $^3\text{H}_2\text{O}$ formation kinetics by cell suspensions of strain KMHW on the hydrogen gas ratio. (A) Relation of $^3\text{H}_2\text{O}$ formation with time to the amount of nonlabeled hydrogen (indicated as milliliters of gas). Controls contained $100 \mu\text{M}$ HgCl_2 . (B) Relation of hydrogenase activity to the hydrogen gas ratio. The experimental conditions were same as for Fig. 4, except cell density was constant at $1.1 \mu\text{g}/\text{ml}$.

that preferential consumption of either isotope was not displayed by strain KMHW. The effect of the gas ratio on $^3\text{H}_2$ transformation by *D. vulgaris*, however, was not linear and demonstrated a preference for the H_2 over the $^3\text{H}_2$ isotope (Fig. 6).

The dependence of $^3\text{H}_2$ transformation by cell suspensions of aerobic hydrogen bacteria on oxygen is shown in Fig. 7. The rate and amount of hydrogen transformed was significantly lowered by replacing air in the reaction headspace with N_2 gas. These experiments were also employed to demonstrate complete consumption of $^3\text{H}_2$ in the presence of air because less than 0.1% of the added tritium was detected in the reaction headspace at the end of these extended time courses. Notably, the $^3\text{H}_2$ transformation activities of *A. eutrophus* and strain KMHW were inhibited by 77 and 96% in control tubes that contained 0.05% sodium sulfide. In other experiments with aerobic cell suspensions of *M. luteus*, *P. aeruginosa*, and *P. fluorescens*, hydrogenase activity was not displayed by these species, which do not consume or produce H_2 during growth.

The effect of various inhibitors on hydrogenase activity in an aerobic hydrogen-consuming bacterium are listed in Table 1. The respiratory uncoupling agent, 2,4-dinitrophenol, did not significantly influence the $^3\text{H}_2$ consumption rate. The artificial electron acceptor, methylene blue, did not increase the $^3\text{H}_2$ consumption rate; instead it was lowered, possibly by blocking active centers. Potassium cyanide inhibited $^3\text{H}_2$ consumption, possibly by poisoning hydrogenase (1) or the cellular oxidase system. HgCl_2 , a

potent inhibitor of hydrogenase totally inhibited activity at $50 \mu\text{M}$ concentration and was equivalent to either treatment with 0.5 M NaOH or boiling the cells for 10 min. High proton and salt concentrations also totally inhibited hydrogen consumption by this aerobic bacterium.

Hydrogen transformation by bacteria in extreme environments. This assay was applied to document the existence of aerobic hydrogen-consuming bacteria in extreme environments which had not been previously reported as niches for this microbial metabolic group. Table 2 describes the physicochemical characteristics and the H_2 transformation activities of a thermal spring and an acid spring in Yellowstone National Park. The physicochemical data reported were identical when sampled in August 1978 and July 1980. The presence of high environmental H_2 levels of either thermochemical origin (thermal spring) or biological origin (acid spring) correlated with biological H_2 transformation activity and the presence of aerobic hydrogen-consuming bacteria. Hydrogen consumption activity was not detected in the presence of HgCl_2 .

Figure 8 illustrates the kinetics of $^3\text{H}_2$ transformation in these two environments. Notably, in the 82°C thermal spring waters, the highest biological activity occurred at 50°C and no activity was detected at 90°C . In the acid spring waters, biological $^3\text{H}_2$ transformation activity was not significant when N_2 replaced air in the reaction tube headspace or in control experiments that contained 0.05% Na_2S or $100 \mu\text{M}$ HgCl_2 to inhibit biological activity or aerobic hydrogen-consuming bacteria. The last positive dilution tube of the most-probable-number de-

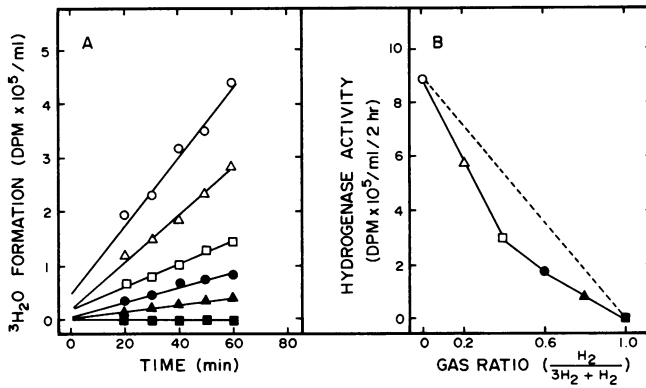

FIG. 6. The effect of diluting ³H₂ in H₂ on (A) the rate of ³H₂O formation and (B) hydrogenase activity of *D. vulgaris* at 37°C. Gas ratios: ■, 0; ▲, 0.2; ●, 0.4; □, 0.6; △, 0.8; ○, 1.0.

terminations from the acid and thermal pool waters were maintained as enrichment cultures and transferred several times in acidic and neutral growth media, respectively. The acidophilic species was isolated and grew at pH 2.5 and was characterized as a gram-negative, obligate acidophile that did not grow above pH 5.5. The culture was deposited in the culture collection of

H. G. Schlegel, University of Gottingen, Gottingen, West Germany. Enrichment cultures of thermophilic aerobic H₂-consuming species were rods that included a long needle-like bacterium, but these cultures were not maintained.

Figure 9 illustrates the relation of water depth to in situ physicochemical parameters at the hypersaline environmental site studied in Great Salt Lake. Temperature, dissolved oxygen, and salinity remained seasonally constant from August 1978 to August 1982 (Paul Sturm, Utah Geological and Mineral Survey, Salt Lake City, personal communication). A pycnocline began

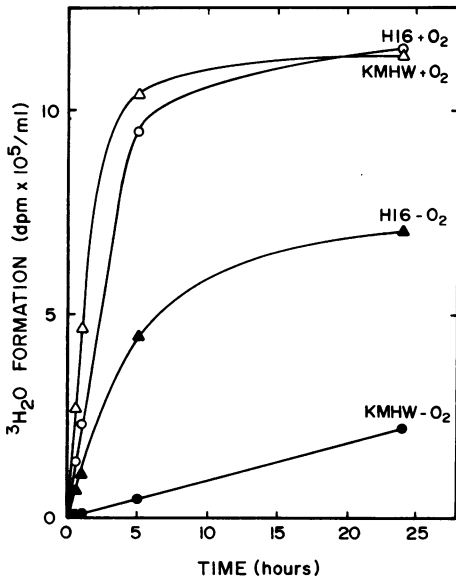

FIG. 7. Dependence of aerobic ³H₂ transformation kinetics on oxygen by cell suspensions of hydrogen bacteria. Experimental conditions: log-phase cells were suspended in 50 mM potassium buffer, pH 7.0, with 50 μg of chloramphenicol per ml and were incubated at 30°C with an air headspace of N₂ in the presence of 0.05% Na₂S and 0.001% resazurin. Symbols: ○, *A. eutrophus* H16 + O₂; △, strain KMHW + O₂; ▲, *A. eutrophus* H16 without O₂; ●, strain KMHW without O₂.

TABLE 1. Influence of effectors on whole cell ³H₂-transformation activity of the aerobic hydrogen bacterium strain KMHW

Effector	Concn or amt	Hydrogenase activity ^a	
		Consumption rates (μmol of ³ H ₂ /min per g of protein)	% Inhibition
None		2,450	0
2,4-Dinitrophenol	10 mM	2,366	4
Methylene blue	0.2 mM	2,114	14
	2.0 mM	1,323	46
Potassium cyanide	1.0 mM	245	90
Formaldehyde	0.4%	906	63
Mercuric chloride	50 mM	<10	100
Sodium hydroxide	0.5 mM	<10	100
Heat	100°C, 10 min	<10	100
Protons	pH 3.0	<10	100
NaCl	22%	<10	100

^a Experimental conditions. Activities were measured with reaction mixtures that contained 10-ml cell suspensions (1.1 μg of protein/ml) in potassium phosphate buffer, pH 7.0, and 1 ml of ³H₂ gas. Activities were calculated from the disintegrations per minute of tritiated water formed per milliliter of suspension after incubation at 30°C for 30-, 60-, and 90-min intervals.

TABLE 2. Relation of physicochemical environmental parameters to the microbial hydrogen transformation of aerobic thermal and acid spring waters^a

Ecosystem	Physicochemistry			Hydrogen consumption activity	
	Temp	H ⁺ activity	Dissolved H ₂ (μl/ml)	Hydrogenase (μl of ³ H ₂ /h)	Cells (hydrogen bacteria per ml)
Washburn Pool B	82	7.0	0.2	5.4	23
Lemonade Pool	40	2.5	0.86	16.25	280

^a Experimental conditions. Surface waters were processed as described in the text. All experiments were incubated under in situ conditions. HgCl₂ (100 μM) was added as the biological control for activity determination.

below a water depth of 7 m and extended to the sediment (~9.5 to 10 m), and O₂ was not detectable below 8 m. The H₂ concentration was as high or higher than the methane concentration in both the anoxic and O₂-containing waters overlying the sediment. Figure 10 illustrates the relation between water depth and microbial hydrogen transformation activities. The number of aerobic hydrogen bacteria and the hydrogenase activity displayed significant increases between 6 and 8 m, which correlated with the depletion of oxygen from these waters.

DISCUSSION

Biological transformation of molecular hydrogen occurs via hydrogenase, which catalyzes the

reaction $H_2 \rightleftharpoons 2H^+ + 2e^-$ (1). This reaction can result in either H₂ consumption or H₂ production. With tritium gas, reversible hydrogenase is catalyzed by the reaction ${}^3H_2 \rightleftharpoons 2{}^3H^+ + 2e^-$; the heavy protons (${}^3H^+$) thus formed exchange with water (aqueous) and generate 3HHO . The environmental concentrations of 3H_2 , H₂, and water greatly influence activity, but since the concentration of water is so high (55.56 mol/liter), exchange of ${}^3H^+$ into water is strongly favored. *C. pasteurianum* displayed 3H_2 transformation activity as a result of the back reaction of its cellular H₂-producing enzymatic machinery. The kinetics of this reaction are proportional to the rate of hydrogen production due to the low 3H_2 concentration relative to the concentrations of H₂ and water. The 3H_2 transformation activity displayed here by aerobic hydrogen bacteria and the anaerobes *D. vulgaris* and *M. barkeri* was the result of hydrogen consumption by cellular hydrogenases, and the rate of transformation was likewise proportional to the rate of hydrogen consumption. However, the data at hand do not allow a distinction to be made between hydrogen-producing or -consuming bacteria by kinetic analysis of hydrogenase-catalyzed 3H_2O generation from 3H_2 . Thus, 3H_2 transformation activity appears to be a measure of hydrogenase activity in living cells, but net hydrogen production or consumption needs to be determined by alternate techniques.

The rate of 3H_2 transformation by the aerobic H₂-consuming bacterium strain KHMW was linear with time, dependent on the H₂/(3H_2 + H₂) ratio and active cell protein concentration. Interestingly, isotopic preferences for H₂ over 3H_2 were not observed for knallgas bacterial strain

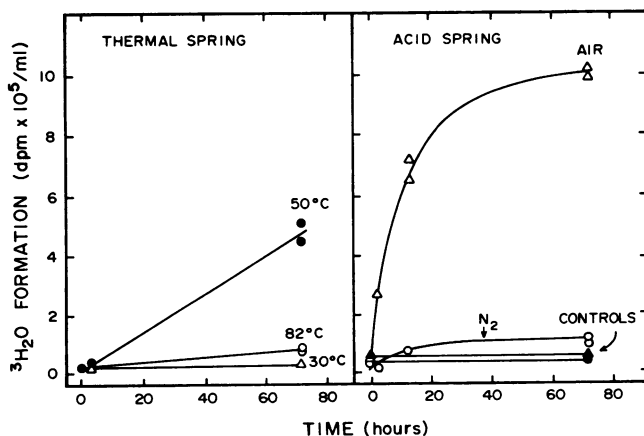

FIG. 8. Dependence of aerobic microbial 3H_2 transformation activity on time in waters from a thermal spring and an acid spring in Yellowstone National Park. Source waters (10 ml) were incubated in six replicate tubes with 3H_2 and air or N₂ as gas headspace; time points were taken before addition of 100 mM HgCl₂. Washburn Pool B waters (thermal spring) were incubated at the temperatures indicated. Lemonade Pool waters (acid spring) were incubated at in situ temperature (40°C) under O₂ or N₂. Controls contained 100 μM HgCl₂ to inhibit hydrogenase activity.

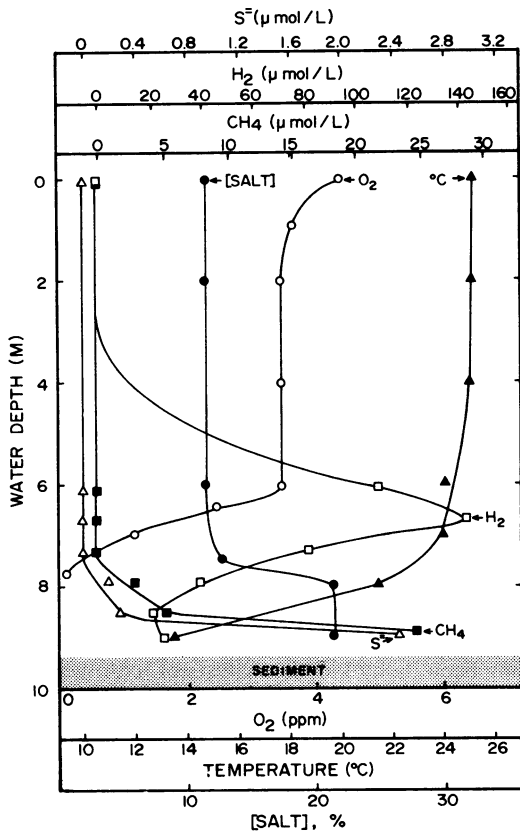

FIG. 9. Relation of water depth to chemical parameters and temperature in the South Arm sampling site in Great Salt Lake, Utah. Salinity and oxygen was measured on 28 July 1980 and the other parameters on 1 August 1982.

KHMW but were for *D. vulgaris* Madison, suggesting that different types of hydrogenases may be found in hydrogen-consuming bacteria. At first glance, the lack of a significantly large discrimination between H_2 and 3H_2 by a hydrogen-consuming bacterium appears enigmatic because of the mass difference between H^+ and $^3H^+$. One speculative explanation is that this may be expected depending on the biochemical mechanism for hydrogen metabolism, which in itself varies greatly in bacteria (1). In addition, the absence of an isotope effect suggests that the isotopically substituted atom is not involved in the rate-determining step (14). Thus, it will be of future importance to examine isotopic discrimination in *M. barkeri* and *C. pasteurianum*. Interestingly, water and not hydrogen is the source of protons for methanogenesis from H_2 - CO_2 (6), whereas glucose is the source of protons and electrons for H_2 formation in *C. pasteurianum* (1).

At this point in time, it can be concluded that

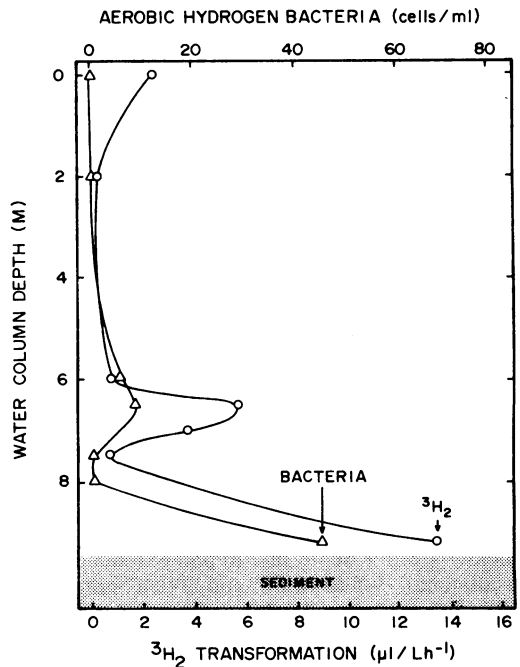

FIG. 10. Relation of aerobic microbial 3H_2 transformation activity and the hydrogen bacteria concentration to Great Salt Lake water depth. The experiments were performed on 28 July 1980.

the 3H_2 transformation activity assay can be used as a practical method for analysis of hydrogenase activity in viable cell samples from the environment or from laboratory culture because of the above and because of the lack of activity displayed by bacterial cultures that do not transform hydrogen. Further detailed studies in a specific environment or a specific bacterial species-metabolic group are required for a detailed understanding of the physiological and ecological significance of microbial hydrogenases. In our lab, we are applying this assay method to experiments aimed at understanding anaerobic hydrogen metabolism by analysis of environmental (both chemical and microbial) parameters of hydrogenase functions in sediment ecosystems and by analysis of altering inter- and intraspecies electron flow in anaerobic bacteria generally considered to either transform H_2 unidirectionally or bidirectionally or to be devoid of hydrogenase. The preliminary results generated appear exciting to biochemical ecologists.

The 3H_2 transformation activity assay was used here to help document the existence of aerobic hydrogen-consuming bacteria in extreme environments. Hydrogen is detected as a dissolved gas in certain thermal volcanic springs (10, 32) as well as in the anoxic and oxygen-

containing water overlying the sediments of hypersaline Great Salt Lake and hyperacidic Lemonade Pool. The specific experimental sites selected in these environments are extremely difficult to study, but nonetheless, hydrogenase activity was repeatedly detected in separate sampling years by the $^3\text{H}_2$ transformation activity assay method. Three other experimental approaches were used to establish the presence of knallgas bacteria in these extreme environments: namely, most-probable-number enumerations of hydrogen-consuming bacteria in the waters; detection of hydrogen in the environment; and net consumption of hydrogen in experimental and end dilution tubes containing $^3\text{H}_2$ diluted in H_2 .

The existence of aerobic thermophilic hydrogen-consuming bacteria in neutral volcanic springs that contain large amounts of geothermal hydrogen (32) was easily predictable because some thermophilic spore-forming species of this metabolic group have been previously described (4). The data here just extend the known diversity of the species and document their niche. However, the discovery of aerobic hydrogen-consuming bacteria and hydrogen partial pressures significantly higher than methane in the overlying sediment waters from Great Salt Lake and Lemonade Pool appears novel at present for both geochemical and microbial reasons. Both salt and protons are known to influence electron flow, as is evidenced by the electrochemistry of the common laboratory pH meter. These two extreme environments differ from neutral, freshwater, or marine ecosystems where hydrogen partial pressure is extremely low in the anoxic sediments or overlying water (11, 19, 25, 27, 29). Hence, extreme environmental concentrations of cations (e.g., H^+ and Na^+) appear to help establish the niche for halophilic or acidophilic bacteria which consume H_2 . The physiological mechanism of knallgas bacterial adaptation to these extreme environments is a challenging problem. For example, the acidophilic species isolated must oxidize H_2 against an unfavorably high external proton concentration. This feature in itself completely inhibited the $^3\text{H}_2$ consumption activity of hydrogenase in the neutralophilic strain KMHW.

The Great Salt Lake sampling site remains a tremendous challenge for future studies because an understanding of why hydrogen is a very significant intermediary product of aerobic and anaerobic metabolism needs clarification. The bacterial $^3\text{H}_2$ transformation activity profile in the hypolimnion of the Great Salt Lake study site parallels that for the microbial $^{14}\text{CH}_4$ oxidation profile in freshwater lakes (19). Aerobic $^3\text{H}_2$ -transformation activity and H_2 -consuming bacteria appear most prolific at the sediment

water interface in Great Salt Lake and in Lake Mendota, Wisconsin (B. Schink and J. G. Zeikus, unpublished data). This finding is novel and suggests that experiments should test whether knallgas bacteria can survive under limiting O_2 or can utilize electron acceptors other than O_2 when H_2 is the electron donor. The detection of maximal H_2 concentration at the pycnocline is another interesting feature that is associated with microbial hydrogenase activity in Great Salt Lake.

The more detailed kinetic data on $^3\text{H}_2$ transformation activity of hydrogen-consuming bacterial cultures supports previous biochemical characterization studies of their hydrogenase (1). The hydrogenases of aerobic bacteria are stable and active when exposed to O_2 in air (20, 23). The hydrogenase activity of aerobic H_2 -consuming bacteria was inhibited by sodium sulfide, whereas hydrogenase activity in the anaerobic species examined was stable to sulfide but inhibited by O_2 . The extent of hydrogenase inhibition by sulfide varied among the aerobic species examined. The $^3\text{H}_2$ -transformation activity was almost totally inhibited in hydrogen bacterium strain KMHW but was only partially inhibited in *A. eutrophus*. *A. eutrophus* has both a membrane-bound and a soluble hydrogenase (21, 22). Also, $^3\text{H}_2$ transformation activity of hydrogen-producing or -consuming anaerobic bacteria was inhibited by CO , a potent inhibitor of reversible hydrogenase (1).

Further studies are required to test the application of this assay procedure for distinguishing between H_2 production or H_2 consumption by anaerobic ecosystems or bacteria in the presence of specific electron flow inhibitors. The assay method may have some merit in analysis of hydrogenase at the natural hydrogen partial pressures because soluble levels of $^3\text{H}_2$ can be used in experiments. The physiological function of bacterial hydrogenases may be compared more accurately by the $^3\text{H}_2$ -transformation assay, because artificial electron carriers, high hydrogen partial pressures, or mixing, can be avoided during characterization of enzyme kinetic features, but the isotopic discrimination of cellular hydrogenase(s) must be well-characterized in the given culture. Thus, it will be of interest to compare the K_m and V_{\max} values for cellular and purified hydrogenase obtained by this method with those obtained via conventional biochemical characterization (1, 13). It will be of special interest to further characterize the physiological ecology of anaerobic H_2 metabolism. In this regard, both sulfate-reducing and methane-forming bacteria compete for available H_2 in freshwater sediments (28) where the in situ rates of both processes are limited by H_2 partial pressure (11, 27).

ACKNOWLEDGMENTS

This research was supported by the College of Agricultural and Life Sciences, University of Wisconsin, and by an educational fellowship from the Deutsche Forschungsgemeinschaft to B.S., by a research grant from Shell Oil Company, and by grant 80EV02161 from the U.S. Department of Energy, Ecological Research Division.

We are indebted to Tom J. Phelps, K. Ingvorsen, Nick Fuex, and Paul Sturm for valuable help in sampling and Steve Goodwin for aid to extensive discussions and calculations. The generous gift of tritium gas by Paul DeLuca, Physical Sciences Lab, University of Wisconsin, is greatly acknowledged.

LITERATURE CITED

- Adams, M. W., L. M. Mortenson, and J. S. Chen. 1981. Hydrogenase. *Biochim. Biophys. Acta* **594**:105-176.
- American Public Health Association. 1969. Standard methods for the examination of water and wastewater including bottom sediments and sludge, p. 604-609. American Public Health Association, Inc., New York.
- Badziong, W., R. K. Thauer, and J. G. Zeikus. 1978. Isolation and characterization of *Desulfovibrio* growing on hydrogen plus sulfate as the sole energy source. *Arch. Microbiol.* **116**:41-49.
- Bowien, B., and H. G. Schlegel. 1981. Physiology and biochemistry of aerobic hydrogen-oxidizing bacteria. *Annu. Rev. Microbiol.* **35**:405-452.
- Conrad, R., and W. Seiler. 1980. Contribution of hydrogen production by biological nitrogen fixation to the global hydrogen budget. *J. Geophys. Res.* **85**:5493-5498.
- Daniels, L., G. Fulton, R. W. Spencer, and W. H. Orme-Johnson. 1980. Origin of hydrogen in methane produced by *Methanobacterium thermoautotrophicum*. *J. Bacteriol.* **141**:694-698.
- Dixon, R. O. D. 1978. Nitrogenase-hydrogenase interrelationships in Rhizobia. *Biochimie* **60**:233-236.
- Eakins, J. D., and W. P. Hutchinson. 1973. The radiological hazard from the conversion of tritium to tritiated water in air by metal catalysts, p. 392-399. *In* A. A. Moghissi and M. W. Carter (ed.), *Tritium*. Messenger Graphics, Phoenix, Arizona.
- Gray, C. T., and H. Gest. 1965. Biological formation of molecular hydrogen. *Science* **148**:186-192.
- Gunter, B. D., and B. C. Musgrave. 1966. Gas chromatographic measurements of hydrothermal emanations at Yellowstone National Park. *Geochim. Cosmochim. Acta* **30**:1175-1189.
- Ingvorsen, K., J. G. Zeikus, and T. D. Brock. 1981. Dynamics of bacterial sulfate reduction in a eutrophic lake. *Appl. Environ. Microbiol.* **42**:1029-1036.
- Jørgensen, B. B. 1980. Mineralization and the bacterial cycling of carbon, nitrogen and sulfur in marine sediments, p. 239-251. *In* D. C. Ellwood, J. N. Helger, M. J. Latham, J. M. Lynch, and J. H. Slater (ed.), *Contemporary microbial ecology*. Academic Press, Inc., London.
- Mackay, K. M., and M. F. A. Dove. 1973. Deuterium and tritium, p. 77-116. *In* J. C. Bailar et al. (ed.), *Comprehensive inorganic chemistry*, vol. 1. Pergamon Press, Inc., Oxford.
- Melander, L., and W. H. Saunders. 1972. Reactions rates of isotopic molecules, p. 2. John Wiley & Sons, New York.
- Nelson D. R., and J. G. Zeikus. 1974. Rapid method for the radioisotopic analysis of gaseous end products of anaerobic metabolism. *Appl. Microbiol.* **28**:258-261.
- Pfennig, N. 1967. Photosynthetic bacteria. *Annu. Rev. Microbiol.* **21**:285-324.
- Pfennig, N., and F. Widdel. 1981. Ecology and physiology of some anaerobic bacteria from the microbial sulfur cycle, p. 167-177. *In* H. Bothe and A. Trebst (ed.), *Biology of inorganic nitrogen and sulfur*. Springer-Verlag, Berlin.
- Postgate, J. R. 1979. The sulphate-reducing bacteria. Cambridge University Press, London.
- Rudd, J. W., R. D. Hamilton, and N. E. R. Campbell. 1974. Measurement of microbial oxidation of methane in lake water. *Limnol. Oceanogr.* **19**:519-524.
- Schink, B., and J. Probst. 1980. Competitive inhibition of the membrane-bound hydrogenase of *Alcaligenes eutrophus* by molecular hydrogen. *Biochem. Biophys. Res. Commun.* **95**:1563-1569.
- Schink, B., and H. G. Schlegel. 1978. Hydrogen metabolism in aerobic hydrogen-oxidizing bacteria. *Biochimie* **60**:297-305.
- Schink, B., and H. G. Schlegel. 1980. The membrane-bound hydrogenase of *Alcaligenes eutrophus*. II. Localization and immunological comparison with other hydrogenase systems. *Antonie van Leeuwenhoek J. Microbiol. Serol.* **46**:1-14.
- Schneider, K., and H. G. Schlegel. 1981. Production of superoxide radicals by soluble hydrogenase of *Alcaligenes eutrophus* H16. *Biochem. J.* **193**:99-107.
- Seiler, W. 1978. The influence of the biosphere on the atmospheric CO and H₂ cycles, p. 773-810. *In* W. E. Krumbein (ed.), *Environmental biogeochemistry and geomicrobiology*. Ann Arbor Science Publishers, Inc., Ann Arbor, Michigan.
- Strayer, R. F., and J. M. Tiedje. 1978. Kinetic parameters of the conversion of methane precursors to methane in a hypereutrophic lake sediment. *Appl. Environ. Microbiol.* **36**:330-340.
- Weimer, P. J., and J. G. Zeikus. 1978. One carbon metabolism in methanogenic bacteria: cellular characterization and growth of *Methanosarcina barkeri*. *Arch. Microbiol.* **119**:49-57.
- Winfrey, M. R., D. R. Nelson, S. C. Kleivickis, and J. G. Zeikus. 1977. Association of hydrogen metabolism with methanogenesis in Lake Mendota sediments. *Appl. Environ. Microbiol.* **33**:312-318.
- Winfrey, M. R., and J. G. Zeikus. 1977. Effect of sulfate on carbon and electron flow during microbial methanogenesis in freshwater sediments. *Appl. Environ. Microbiol.* **33**:275-281.
- Winfrey, M. R., and J. G. Zeikus. 1979. Anaerobic metabolism of immediate methane precursors in Lake Mendota. *Appl. Environ. Microbiol.* **37**:244-253.
- Zeikus, J. G. 1977. The biology of methanogenic bacteria. *Bacteriol. Rev.* **41**:514-541.
- Zeikus, J. G. 1983. Metabolic communication between biodegradative populations in nature, p. 423-462. *In* J. H. Slater, R. Whittenbury, and J. W. T. Wimpenny (ed.), *Microbes in their natural environments*. Symposium for Society of General Microbiology series, vol. 34. Cambridge University Press, Cambridge, England.
- Zeikus, J. G., A. Ben-Bassat, and P. W. Hegge. 1980. Microbiology of methanogenesis in thermal, volcanic environments. *J. Bacteriol.* **143**:432-440.