

Use of Platinum Electrodes for the Electrochemical Detection of Bacteria

JUDD R. WILKINS

National Aeronautics and Space Administration, Langley Research Center, Hampton, Virginia 23665

Received for publication 14 August 1978

Platinum electrodes with surface area ratios of four to one were used to detect and enumerate a variety of gram-positive and gram-negative organisms. Linear relationships were established between inoculum size and detection time. End points for platinum electrodes were similar to those obtained with a platinum-reference electrode combination. Shape of the overall response curves and length of detection times for gram-positive organisms were markedly different than those for the majority of gram-negative species. Platinum electrodes are better than the platinum-reference electrode combination because of cost, ease of handling, and clearer definition of the end point.

Recently, Wilkins et al. (3, 4) described an electrochemical method for detecting bacteria based on the time of hydrogen evolution. The test system consisted of a platinum and reference electrode connected to a strip-chart recorder; hydrogen evolution was measured by an increase in voltage in the negative (cathodic) direction. A linear relationship was established between inoculum size and the time hydrogen was detected. This investigation presents the results of an evaluation of platinum electrodes for detecting and enumerating a variety of bacteria.

MATERIALS AND METHODS

Cultures. The following cultures were obtained from the American Type Culture Collection (Rockville, Md.): *Escherichia coli* 12014, *Enterobacter aerogenes* 13882, *Citrobacter intermedium* 6750, *Citrobacter freundii* 8090, *Serratia marcescens* 13880, *Pseudomonas aeruginosa* 17934, *Klebsiella pneumoniae* 13046, *Alcaligenes faecalis* 8750, *Proteus mirabilis* 12453, *Staphylococcus aureus* 12600, *Staphylococcus epidermidis* 155, *Streptococcus faecalis* 14428, *Streptococcus pyogenes* 12384, and *Sarcina lutea* 381. Cultures were maintained at 5°C on Trypticase soy agar slants (BBL) and transferred monthly.

Inoculum preparation, viable counts, and media. Inocula for the platinum electrode measurements were prepared by making 10-fold dilutions of a 24-h Trypticase soy broth culture (BBL) in sterile 0.05% peptone broth and adding 2 ml of appropriate dilutions to 18 ml of brain heart infusion broth (Difco) or Trypticase soy broth prewarmed to 35°C. Viable counts were made by spreading appropriate dilutions from the 10-fold series on Trypticase soy agar and counting colonies after 24 or 48 h of incubation at 35°C.

Platinum electrode measurements. The experimental setup for detecting test organisms with platinum

electrodes is shown in Fig. 1. It consisted of a test tube (25 by 150 mm) containing two platinum electrodes plus 20 ml of broth and positioned in a 35°C incubator. The electrodes, grade A platinum alloy wire, 24 gauge (0.508 mm) (Engelhard Industry, Carteret, N.J.), were inserted into slits made in a no. 3 rubber stopper and bound with wire to prevent slippage. The electrodes were configured so that 10 and 40 mm were immersed in the broth. The electrodes and rubber stopper were sterilized between tests by flaming in a Bunsen burner. Before the electrodes were connected to the strip-chart recorder (model 194, Honeywell Industrial Division, Fort Washington, Pa.), each channel was set at a zero reference point. The 10- and 40-mm electrodes were connected to the positive and negative terminals, respectively, of the recorder operated at 0.2 or 0.5 V full scale, with a chart speed of 10 min/inch (25.4 mm). The electrodes were allowed to equilibrate for 60 to 80 min before establishing a base line, which was generally offset from the recorder zero reference point by 10 to 20 mV in the positive direction. Responses in the upward direction from the base line were considered positive, and those in the downward direction were considered negative. Millivolt measurements for peak height responses were made from the base line in either the positive or the negative direction. Detection time end points (lag time) were read from the strip-chart trace and recorded as the time between challenge and the initial increase in voltage. Each trace was characterized as to the type of response curve, and the maximum millivolt response was also recorded.

RESULTS

Preliminary studies indicated that the shape of strip-chart response curves was influenced by the length of the platinum electrodes immersed in the broth. When both electrodes were the same length, viz., 40 mm, the response, at the time of an end point, was jagged with oscillations

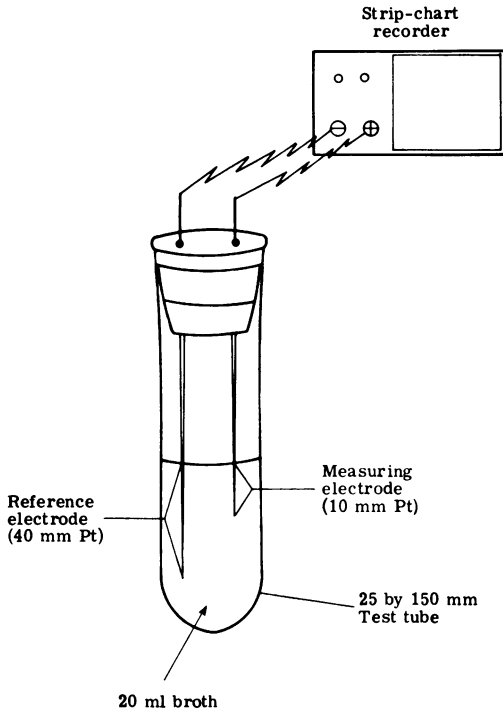

FIG. 1. Experimental setup for detecting bacteria, using platinum electrodes.

in both the positive and negative directions. By decreasing the length of one electrode to 10 mm, while maintaining the length of the other electrode at 40 mm, response curves of the type shown in Fig. 2 were obtained. The 14 test organisms could be placed in two groups depending on the shape of the strip-chart response curve (Fig. 2). In group I, for 80 to 90 min after the end point, there was a steady increase in voltage to levels of 25 to 30 mV followed by a sharp increase in response to peaks of 100 to 250 mV, with a subsequent decline in response. Organisms that displayed a group I response were *E. coli*, *E. aerogenes*, *C. intermedium*, *C. freundii*, *K. pneumoniae*, and *P. mirabilis*. In group II, the response after the initial increase in voltage was constant until peak values of 10 to 50 mV were reached, with no decline in voltage. These response curves, with the exception of those for *S. aureus* and *S. marcescens*, consisted of a series of undulations beginning shortly after the end point. Organisms that displayed a group II response were *S. aureus*, *S. epidermidis*, *S. pyogenes*, *S. faecalis*, *S. lutea*, *A. faecalis*, *P. aeruginosa*, and *S. marcescens*. In 46 cases (19.9%) of 231 tests with 10- and 40-mm electrodes, the responses were in the negative direction. These responses appeared to be random

events and could not be correlated with the organisms, media, electrodes, strip-chart recorder, or inoculum size. When the responses were in the negative direction, the strip-chart patterns were the same as responses in the positive direction for both group I and II organisms.

When inoculum size was plotted against detection time, the relationships were linear for the organisms tested (Fig. 3). Generally, the gram-negative species had similar dose-response curves, with detection times ranging from 2 h for 10^6 cells per ml to 9 h for 10^0 cells per ml. The two exceptions, *P. aeruginosa* and *A. faecalis*, had extended end points, especially at the lower cell concentrations of 10^0 to 10^3 cells per ml. Detection time end points for the gram-positive organisms were considerably longer than for the gram-negative species. In general, for an inoculum of 10^0 cells per ml, detection times ranged from 14 to 24 h with the exception of *S. lutea*, in which the minimum cell concentration detected at 24 h was 10^3 cells per ml. The standard error of the estimate was calculated for each dose-response curve, and the mean values were 0.34 and 0.30 for gram-negative and gram-positive organisms, respectively. Because the standard error of the estimate could be interpreted as a standard deviation, 68% of the responses fell within 0.64 and 0.60 logarithm about the regression line. No differences were noted between the media Trypticase soy broth and brain heart infusion broth in end points, shape of the response curve, and the standard error of the estimate. A summary of the least-squares method of analyzing detection time data is shown in Table 1. The slopes of the gram-negative species were similar with the exceptions of

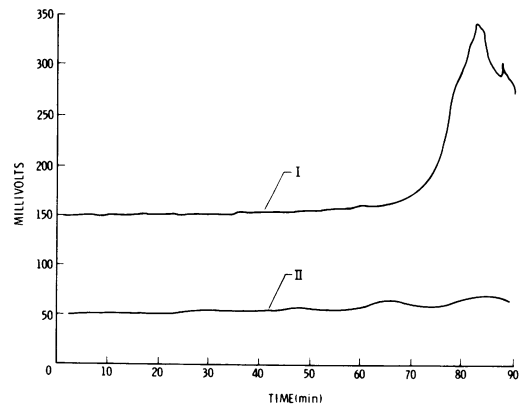

FIG. 2. Shape of strip-chart response curves for gram-negative organisms, group I; except *S. marcescens*, *A. faecalis*, and *P. aeruginosa*, which resembled the response curves for gram-positive organisms, group II.

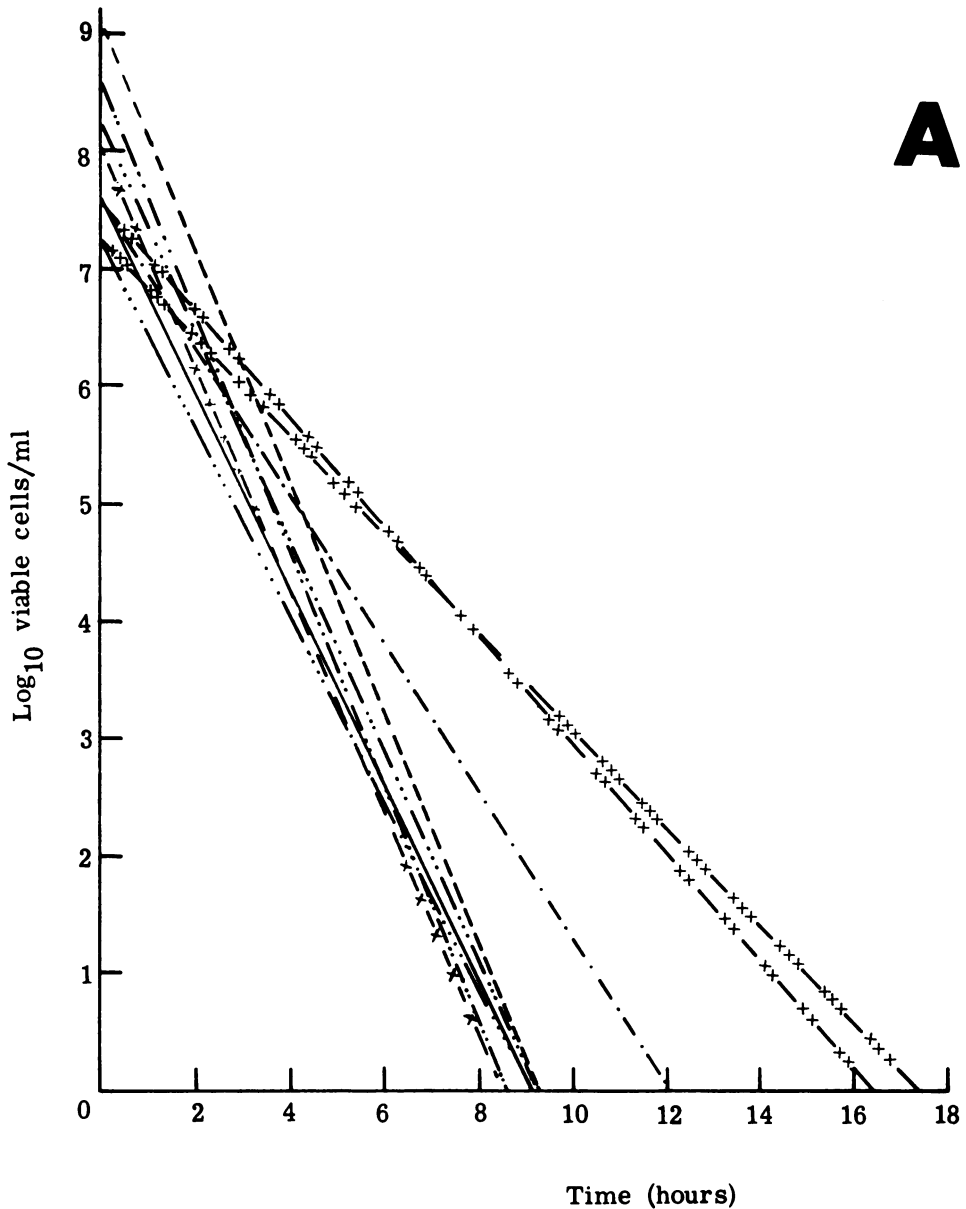

FIG. 3. Relationship between inoculum size and length of detection time for (A) gram-negative organisms: (—) *E. coli*; (---) *E. aerogenes*; (-·-·-) *C. freundii*; (-·-·-) *C. intermedium*; (-·-·-) *S. marcescens*; (-·-·-) *P. mirabilis*; (-x-x-) *K. pneumoniae*; (-x-x-) *P. aeruginosa*; (-x-x-x-) *A. faecalis*. (B) Gram-positive organisms: (—) *S. aureus*; (---) *S. epidermidis*; (-·-·-) *S. faecalis*; (-·-·-) *S. pyogenes*; (-·-·-) *S. lutea*. Lines were fitted by the method of least squares; test medium was Trypticase soy broth.

A. faecalis and *P. aeruginosa*, which resembled the gram-positive organisms. No differences were noted between the two media in slopes, intercepts, and correlation coefficients (*t*-test, α not significant at the 0.05 level).

DISCUSSION

A comparison of platinum electrodes with the platinum-reference electrode combination revealed a number of similarities in detection

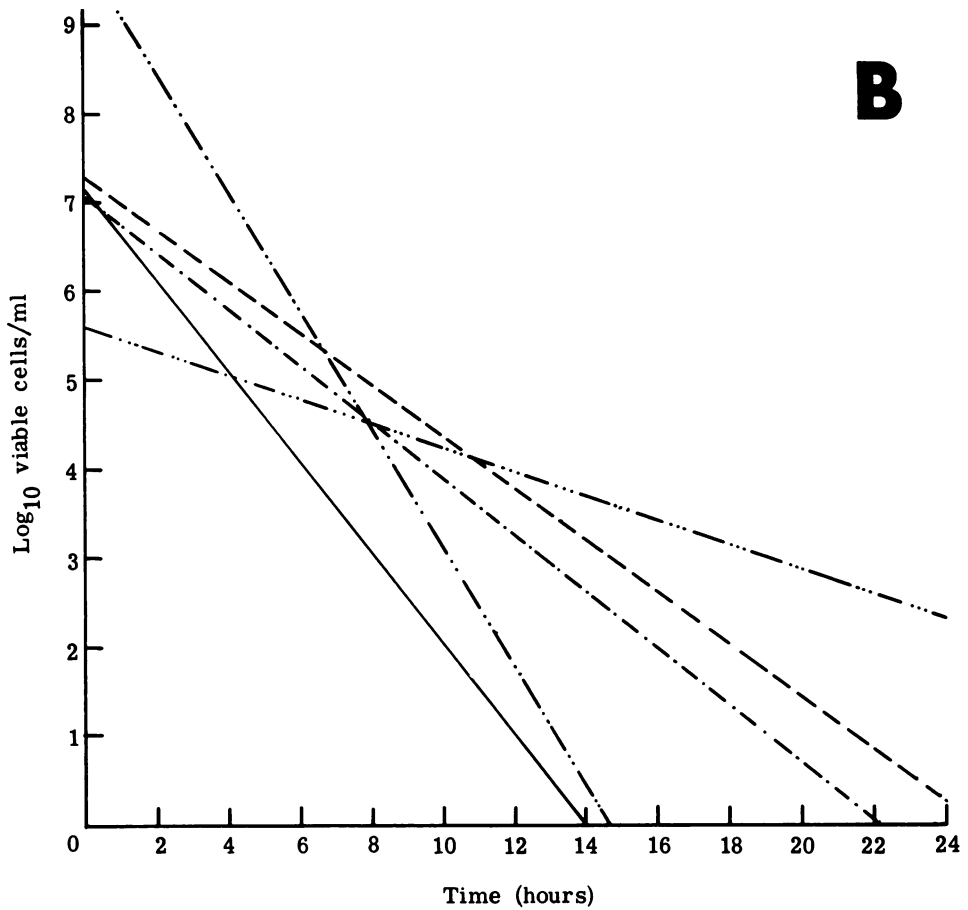

Fig. 3B.

TABLE 1. Summary of analysis of detection time data by method of least squares^a

Organism	Parameters						Mean maximum mV response	
	Slope		Intercept (log ₁₀)		Correlation coefficient		TSB	BHB
	TSB	BHB	TSB	BHB	TSB	BHB		
<i>Escherichia coli</i>	-0.0139	-0.0127	7.6136	7.6889	0.9453	0.9803	234	140
<i>Enterobacter aerogenes</i>	-0.0164	-0.0152	9.1289	8.1679	0.9906	0.9598	66	120
<i>Citrobacter freundii</i>	-0.0105	-0.0106	7.5672	7.6086	0.9958	0.9520	174	100
<i>Citrobacter intermedium</i>	-0.0167	-0.0145	8.5577	7.8612	0.9663	0.9300	187	217
<i>Serratia marcescens</i>	-0.0148	-0.0129	8.2479	7.1992	0.9918	0.9881	20	30
<i>Proteus mirabilis</i>	-0.0132	-0.0162	7.2492	7.9097	0.9876	0.9932	142	118
<i>Klebsiella pneumoniae</i>	-0.0142	-0.0133	7.9916	7.6944	0.9978	0.9801	185	108
<i>Pseudomonas aeruginosa</i>	-0.0075	-0.0085	7.5590	7.3089	0.9875	0.9980	24	15
<i>Alcaligenes faecalis</i>	-0.0068	-0.0062	7.2129	7.7812	0.9352	0.9944	23	14
<i>Staphylococcus aureus</i>	-0.0085	-0.0115	7.1686	8.6634	0.9644	0.9859	28	30
<i>Staphylococcus epidermidis</i>	-0.0051	-0.0057	7.3645	8.0609	0.9922	0.9580	33	24
<i>Streptococcus faecalis</i>	-0.0054	-0.0047	7.1168	8.7069	0.9951	0.9993	66	70
<i>Streptococcus pyogenes</i>	-0.0111	-0.0086	9.8402	8.0219	0.9805	0.9956	12	15
<i>Sarcina lutea</i>	-0.0040	-0.0024	7.3200	5.6280	0.8976	0.9833	21	7.0

^a Based on 10 to 12 data points for an inoculum range of 10⁰ to 10⁶ cells per ml. TSB, Trypticase soy broth; BHB, brain heart infusion broth.

times and strip-chart response patterns. For both test systems, the hydrogen-producing bacteria, i.e., *Escherichia*, *Citrobacter*, *Klebsiella*, etc., had similar response patterns consisting of a lag period followed by a sharp increase in voltage and then a decline period. The magnitude of the responses was greater with the combination electrodes, viz., 400 to 500 mV versus 100 to 200 mV for the platinum electrodes. Detection time end points with platinum electrodes were extended by 2 h when compared with the combination electrodes. This difference was reflected in the slopes of the liner regression lines, but good agreement was shown in the high correlation coefficients for the two systems. When tested with the two systems, the response patterns for gram-positive organisms plus *S. marcescens*, *A. faecalis*, and *P. aeruginosa* consisted of a lag period followed by a gradual increase in response to maximum levels of 50 mV with no marked decline in voltage. Extended detection time end points for this group of organisms were observed with both types of electrodes (1). Another point of similarity with both types of electrodes was noted at the time of an end point when cell concentrations were 10^5 to 10^6 /ml and no marked change in pH had occurred. Although these general similarities were noted and the principle behind the detection of bacteria with platinum electrodes has not been established, it is of interest to review some of the factors associated with this method.

Of particular interest was the observation that platinum electrodes behaved, in general, like the platinum-standard reference electrode combination. This was evident not only in detection times but also in the shapes of the strip-chart response curves and suggests a common mechanism for the two detection systems. Another factor was evident in the relationship between the surface area ratios of the two platinum electrodes and the type of response obtained. When the surface areas were equal, the response patterns oscillated between the positive and negative directions and the results were not reproducible. The fact that the surface area ratios of the two electrodes were different before consistent responses were obtained suggested that a differential in potential was being established between the electrodes. Therefore, one could view the 10-mm electrode as the measuring electrode and the 40-mm length as the reference electrode. This would be analogous to the com-

bination electrodes in which platinum was the measuring electrode and the glass calomel electrode acted as the reference. One important point that has not been resolved, however, is the source of charge needed to produce a response. Although the principle behind the combination electrodes delineates the source of electrons for hydrogen-producing bacteria, it does not account for the responses obtained with non-hydrogen-producing organisms or the results with platinum electrodes. Some possible research approaches were suggested from these studies and include the nature of the strip-chart response curves, the relationship between cell concentration (10^5 to 10^6 /ml) at the time an end point was obtained, and the generation rates of the organisms. Still another possibility could be Mitruka and Bonner's (2) explanation for the electrical impedance method of detecting bacteria: "As nutrients such as carbohydrates are metabolized into products such as lactates and carbonates, large, electrically inert molecules are replaced by a large number of electrically active molecules and ions, thus increasing the electrical conductivity of the medium."

Limited studies indicated that palladium could also be used to detect bacteria and suggest that the noble metals in general are suitable electrode material. Other metals such as nickel, stainless steel, etc., have not been tested. On a comparative basis, platinum electrodes cost considerably less than combination or redox electrodes, and they are easier to handle, maintain, and sterilize. Detection time end points with platinum electrodes were easier to read than the gradual responses observed with the combination electrodes. The inherent simplistic nature of platinum electrodes makes them attractive not only for detecting microorganisms, but also as useful research tools.

LITERATURE CITED

1. Lamb, V. A., H. P. Dalton, and J. R. Wilkins. 1976. Electrochemical method for the early detection of urinary-tract infections. *Am. J. Clin. Pathol.* **66**:91-95.
2. Mitruka, B. M., and M. J. Bonner. 1976. Methods of detection and identification of bacteria. CRC Press, Cleveland.
3. Wilkins, J. R., and E. H. Boykin. 1976. Electrochemical method for early detection and monitoring of coliforms. *Am. Water Works J.* **68**:257-263.
4. Wilkins, J. R., G. E. Stoner, and E. H. Boykin. 1974. Microbial detection method based on sensing molecular hydrogen. *Appl. Microbiol.* **27**:949-952.