

# Functional Properties and Genomics of Glucose Transporters

Feng-Qi Zhao\* and Aileen F. Keating

*Lactation and Mammary Gland Biology Group, Department of Animal Science, University of Vermont, Burlington, VT, USA*

**Abstract:** Glucose is the major energy source for mammalian cells as well as an important substrate for protein and lipid synthesis. Mammalian cells take up glucose from extracellular fluid into the cell through two families of structurally-related glucose transporters. The facilitative glucose transporter family (solute carriers SLC2A, protein symbol GLUT) mediates a bidirectional and energy-independent process of glucose transport in most tissues and cells, while the Na<sup>+</sup>/glucose cotransporter family (solute carriers SLC5A, protein symbol SGLT) mediates an active, Na<sup>+</sup>-linked transport process against an electrochemical gradient. The GLUT family consists of thirteen members (GLUT1-12 and HMIT). Phylogenetically, the members of the GLUT family are split into three classes based on protein similarities. Up to now, at least six members of the SGLT family have been cloned (SGLT1-6). In this review, we report both the genomic structure and function of each transporter as well as intra-species comparative genomic analysis of some of these transporters. The affinity for glucose and transport kinetics of each transporter differs and ranges from 0.2 to 17mM. The ability of each protein to transport alternative substrates also differs and includes substrates such as fructose and galactose. In addition, the tissue distribution pattern varies between species. There are different regulation mechanisms of these transporters. Characterization of transcriptional control of some of the gene promoters has been investigated and alternative promoter usage to generate different protein isoforms has been demonstrated. We also introduce some pathophysiological roles of these transporters in human.

Received on: December 6, 2006 - Revised on: December 8, 2006 - Accepted on: December 17, 2007

**Key Words:** Bioinformatics, comparative genomics, genomic organization, gene promoter, glucose transporters.

## INTRODUCTION

Glucose is a major energy source and is an important substrate for both protein and lipid synthesis in mammalian cells. It provides energy in the form of ATP through glycolysis and the citric acid cycle and reducing power in the form of NADPH through the pentose phosphate shunt. It is also used in the synthesis of glycerol for triglyceride production and provides intermediates for synthesis of non-essential amino acids. In lactating animals, a major portion of blood glucose is used for synthesis of lactose, the major milk carbohydrate, in the mammary gland. The plasma membranes of virtually all mammalian cells possess one or more transport systems to allow glucose movement either into or out of the cells. In mammals, since blood glucose levels are maintained within a narrow range by homeostatic mechanisms, most cells take up glucose from interstitial fluid by a passive, facilitative transport process, driven by the downward glucose concentration gradient across the plasma membrane [1]. This facilitative transport is inhibitable by cytochalasin-B or phloretin. Only in the epithelial cell brush border of the small intestine and the kidney proximal convoluted tubules, glucose is absorbed or reabsorbed against its electrochemical gradient by a secondary active transport mechanism which uses the sodium concentration gradient established by Na<sup>+</sup>/K<sup>+</sup>/ATP pumps. This sodium dependent transport can be inhibited by phlorizin.

The facilitative and sodium-dependent glucose transport processes are mediated by two distinct families of structurally related glucose transporters (Table 1). The passive, facilitative transport process is mediated by the family of facilitative glucose transporters (gene symbol SLC2A, protein symbol GLUT). Thirteen members of this family have been identified, GLUT 1-12 and HMIT, plus four pseudogenes [2]. The sodium-dependent glucose transport process is mediated by the family of Na<sup>+</sup>/glucose cotransporters (gene symbol SLC5A, protein symbol SGLT). Thus far, at least six members of this family have been reported [3], but only SGLT1 and SGLT2 have been well characterized.

## STRUCTURAL CHARACTERISTICS OF GLUT AND SGLT PROTEINS

A genome wide GenBank search indicates that the GLUT1-12 and HMIT may represent all facilitative glucose transporter members in human [4]. These proteins are structurally conserved and related. The hydropathy plot analysis of these proteins indicates that this family of transporters may have a tertiary structure of 12 transmembrane domains (TM) [4]. Sequence comparisons of all 13 family members show that the sequences are more conserved in the putative transmembrane regions and more divergent in the loops between the TM and in the C- and N- terminal regions (Fig. 1A). The most divergent regions are loops 1 and 9 and the two terminal regions. Overall, the sequences among 13 members are 14-63% identical and 30-79% conservative. Sequence alignments of all members also reveal several highly conserved structures, the characteristic sugar trans-

\*Address correspondence to this author at the Lactation and Mammary Gland Biology Group, Department of Animal Science, University of Vermont, 219 Terrill, 570 Main Street, Burlington, VT 05405, USA; Tel: 802-656-0786; Fax: 802-656-8196; E-mail: fzhao@uvm.edu

**Table 1. Summary of the Properties of Facilitative Glucose Transporter and Na<sup>+</sup>/Glucose co-Transporter Family Members**

Protein	Major isoform (aa) <sup>1</sup>	K <sub>m</sub> <sup>2</sup> (mM)	Major sites of expression	Proposed function
<b>Facilitative glucose transporters (GLUT)</b>				
GLUT1	492	3-7	Ubiquitous distribution in tissues and culture cells	Basal glucose uptake; transport across blood tissue barriers
GLUT2	524	17	Liver, islets, kidney, small intestine	High-capacity low-affinity transport
GLUT3	496	1.4	Brain and nerves cells	Neuronal transport
GLUT4	509	6.6	Muscle, fat, heart	Insulin-regulated transport in muscle and fat
GLUT5	501		Intestine, kidney, testis	Transport of fructose
GLUT6	507	? <sup>3</sup>	Spleen, leukocytes, brain	
GLUT7	524	0.3	Small intestine, colon, testis	Transport of fructose
GLUT8	477	2	Testis, blastocyst, brain, muscle, adipocytes	Fuel supply of mature spermatozoa; Insulin-responsive transport in blastocyst
GLUT9	511/540	?	Liver, kidney	
GLUT10	541	0.3	Liver, pancreas	
GLUT11	496	?	Heart, muscle	Muscle-specific; fructose transporter
GLUT12	617	?	Heart, prostate, mammary gland	
HMIT	618/629	?	Brain	H <sup>+</sup> /myo-inositol co-transporter
<b>Na<sup>+</sup>/glucose cotransporters (SGLT)</b>				
SGLT1	664	0.2	Kidney, intestine	Glucose reabsorption in intestine and kidney
SGLT2	672	10	Kidney	Low affinity and high selectivity for glucose
SGLT3	660	2	Small intestine, skeletal muscle	Glucose activated Na <sup>+</sup> channel

<sup>1</sup>aa, amino acids. <sup>2</sup>Net influx for 2-Deoxyglucose or glucose; <sup>3</sup>?=unknown.

porter signatures: PMY in TM4, PESPRY/FLL in loop 6, QQLSGIN in TM7, GRR in loop 8, GPGPIP/TW in TM10, and VPETKG in the C-terminal tail (Fig. 1A). In addition, there are 18 conserved glycine residues, 11 of them are adjacent to at least one other conserved amino acid. Experimentally, the tryptophan in the GPGPIP/TW motif of TM10 (W388 of human GLUT1) has been shown to be critical for GLUT1 binding of ligands cytochalasin B and forskolin and the tryptophan conserved in all GLUTs in TM11 (W412) is essential for GLUT1 transport activity and targeting to the plasma membrane [5, 6]. Exchange of the conserved arginine in loop 2 (R92), two arginines in loop 8 (RR333/334), glutamate in loop 8 (E329), proline in TM10 (P385), glutamate (E393) or arginine in loop 10 (R400) either reduced or suppressed glucose transport activity of GLUT1 or GLUT4 with no or very little effect on cytochalasin B binding while exchange of the conserved glutamate (E146) or arginine (R153) in loop 4, or tyrosine in loop 7 (Y293) markedly reduced glucose transport activity and cytochalasin B binding [7-9]. These data suggest that the conserved amino acids play important roles in substrate binding and/or in the conformational change during the transport process. The presence of a common motif suggests that this family may have originated from a common ancestral gene. Both the amino

and carboxy-terminals of GLUTs are considered to be located in the cytoplasm. The last 24 amino acids at the C-terminus of GLUT1 have been shown to be unnecessary for the transport activity [10].

Based on the phylogenetic analysis of sequence similarity, the GLUT family of sugar transporters are divided into three classes (Fig. 1B) [2]. Class I includes GLUT1-4 which are 48-63% identical in human and have been extensively characterized. Class II is comprised of GLUT5, 7, 9 and 11 which are 36-40% identical. The proteins in this class have transport activity for fructose. Structurally, these transporters do not have the tryptophan residue shown to be important for binding of ligands cytochalasin B and forskolin [5] in the GPGPIP/TW motif of TM10. Class III is composed of GLUT6, GLUT8, GLUT10, GLUT12 and HMIT. Although this class of transporters are only 19-41% identical, they share a structural characteristic of the presence of a larger loop 9 containing a glycosylation site in comparison to a larger extracellular loop 1 containing the glycosylation site in the transporters of other classes. It has been well established that the N- and O-glycosylation of GLUT1 is essential for its transporter activity [11-14]. Interestingly, the glycosylation of GLUT2 has been linked to the dietary effect of insulin secretion [15].

A

Sequence alignment of GLUT1-12 and HMIT proteins. The table shows amino acid sequences for each protein, with positions 20-120, 140-240, 260-360, 380-480, and 500-600. Transmembrane domains (TM1-TM12) are indicated by dashed lines above the sequences. Conserved motifs like 'E P R G' and 'W N V F' are highlighted in bold. The HMIT protein sequence is shown in a lighter font.

(Fig. 1) contd....

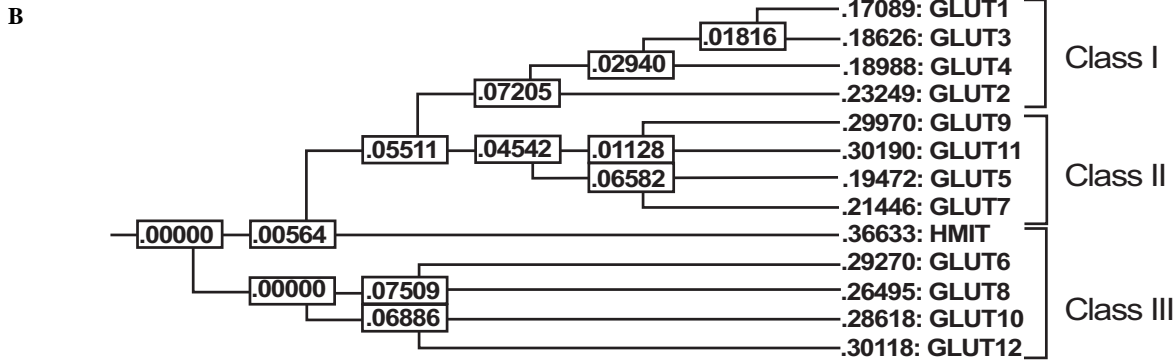

**Fig. (1).** A. Multiple sequence alignment of the deduced amino acid sequence of human facilitative transporters. The GenBank protein identification numbers of these transporters are NP\_006507.1 (GLUT1), NP\_000331.1 (GLUT2), NP\_008862.1 (GLUT3), NP\_001033.1 (GLUT4), NP\_003030.1 (GLUT5), NP\_060055.1 (GLUT6), NP\_997303.1 (GLUT7), NP\_055395.2 (GLUT8), NP\_064425.2 (GLUT9), NP\_110404.1 (GLUT10), NP\_110434.2 (GLUT11), NP\_660159.1 (GLUT12) and NP\_443117.2 (HMIT). The alignment was performed with the CLUSTAL W program with open gap cost = 10 and gap extension cost = 0.2. Residues that are highlighted by black shading background represent absolutely conserved amino acids and the gray shading indicates six or more conserved residues at that position. Positions of presumed membrane-spanning helices (TM) of the GLUT proteins (Joost and Thorens, 2001) are given by the numbered dashed lines at the top of the sequence alignment. In addition, the highly conserved amino acids are shown on the bottom of the sequence alignment. B. Phylogenetic tree of the facilitative glucose transporters drawn from the multiple sequence alignment by CLUSTAL W. The numbers represent tree weights. The three classes of GLUT proteins are indicated.

The members of the SGLT family also share considerable homology among the proteins (21-70% amino acid identity to SGLT1) and contain several conserved sodium:solute symporter family signatures that are characteristics of this family (GenBank accession numbers PS00456, PS00457 and PS50283). The SGLTs are predicted to have 14-15 transmembrane helices [3, 16, 17]. This second structural model is supported by experimental data of glycosylation studies, antibody tagging, mass spectrometry and other methods [3]. The hydrophilic N-terminus is located on the extracellular surface of the plasma membrane. There are several consensus sites for N-linked glycosylation [16, 17], however, glycosylation appears not to be required for SGLT1 activity in contrast to GLUT1 [3].

### CHROMOSOME LOCATION AND GENOMIC ORGANIZATION OF GLUCOSE TRANSPORTERS IN HUMAN

Based on the BLAST search of the GenBank human genome database (Build 36.2), all GLUT genes are single copy genes and distributed in 9 chromosomes in human (Table 2). GLUT1, 5 and 7 are localized in chromosome 1 and GLUT5 and 7 are very closely arranged in a cluster (1p36.22-36.2). Similarly, GLUT6 and 8 are very closely located in chromosome 9 (9q33.3-34). These genes potentially arose from gene duplication. Both GLUT3 and HMIT are located in chromosome 12. GLUT2, 4, 9, 10, 11, and 12 are individually located in chromosome 3, 17, 4, 20, 22 and 6, respectively. The exon numbers of these genes ranges from 5 (GLUT10 and 12) to 13 (GLUT9 and 11). The sizes of these genes are generally small, ranging from only 6-8 kb (GLUT4 and 6) to 65 kb (GLUT12), except for GLUT9 and HMIT (214 and 351 kb respectively). The exon distributions of the GLUT genes are shown in Table 2. Although all GLUT genes are single copy genes, multiple variants which result from alter-

native splicing or promoter use have been observed at least for GLUT 9 and 11. At least three variants have been observed for both GLUT9 [18-19] and GLUT11 [20, 21].

The Na<sup>+</sup>/glucose cotransporters SGLT1 and 2 are also single copy genes and are located on human chromosome 22 and 16 respectively (Table 2). They have 14-15 exons with gene sizes of approximately 67 kb (SGLT1) and 8 kb (SGLT2).

### TISSUE DISTRIBUTION AND FUNCTIONAL PROPERTIES OF GLUCOSE TRANSPORTERS

Using heterologous transport systems, almost all of the GLUT and SGLT proteins have been shown to transport glucose but with different kinetics and efficiencies for glucose and hexose transport. Each isoform has a tissue-specific distribution and more than one isoform may be expressed in the same tissue at either the same or different times. The expression of these genes has been shown to be differentially regulated. The known kinetic properties, major sites of expression and proposed function of each of these transporters in human and rodent tissues are summarized in Table 1. These differences reveal that each transporter isoform plays a specific role in glucose uptake in various tissues and in glucose homeostasis.

#### GLUT1 (SLC2A1)

The GLUT1 isoform is also known as the erythrocyte, brain, or Hep-G2-Type glucose transporter and comprises 3-5% of the erythrocyte total membrane protein. GLUT1 mRNA has been detected in the mouse embryo between the oocyte to the blastocyst stages [22] and in a variety of human and animal tissues, being the most ubiquitously distributed isoform. In particular, it is expressed at high levels in endothelial and epithelial-like barriers of the brain, eye, peripheral nerve, placenta and lactating mammary gland [23, 24]. It

Table 2. Genomic Localization and Organization of Human Glucose Transporters

Gene	Chromosome Location	Exon No.	Gene length (kb)	Exon distribution	
				■ - coding region	■ - untranslated region
GLUT1	1p35-p31.3	10	33		
GLUT2	3q26-1-q26.2	11	31		
GLUT3	12p13.3	10	17		
GLUT4	17p13	11	6		
GLUT5	1p36.2	12	33		
GLUT6	9q34	10	8		
GLUT7	1p36.22	12	23		
GLUT8	9q33.3	10	11		
GLUT9	4p16-p15.3	12-13	214		
GLUT10	20q13.1	5	27		
GLUT11	22q11.2	10-13	28		
GLUT12	6q23.2	5	65		
HMIT	12q12	10	351		
SGLT1	22q12.3	15	67		
SGLT2	16p12-p11	14	8		

The information was obtained by aligning the cDNA sequences of individual GLUT proteins with the human genomic sequence (Build 36.2) using the NCBI BLAST program (<http://www.ncbi.nlm.nih.gov/blast/>). The diagrams of exon distribution are adapted from NCBI Entrez Gene websites (<http://www.ncbi.nlm.nih.gov/entrez/query.fcgi?db=gene>).

has been shown to have a critical role in development of the vertebrate brain [25]. GLUT1 protein also acts in a cooperative manner with other isoforms and this is evident by the interaction between GLUT1 and GLUT4 in the insulin-sensitive tissues, fat and muscle, where the GLUT1 protein is localized to the plasma membrane, and the tissue-specific GLUT 4 is distributed in an intracellular compartment in the basal state. During response to insulin signalling, GLUT4 is translocated to the plasma membrane [26].

The glucose transport activity of GLUT1 has been tested in *Xenopus* oocytes in which the GLUT1 transports glucose with a  $K_m$  of 20-21 mM for 3-O-methylglucose under equilibrium exchange flux conditions [27, 28], 5 mM 2-deoxy-D-glucose [29] and ~3 mM for glucose [30]. The other transport substrates of GLUT1 include galactose, mannose and glucosamine [30].

The deduced protein sequence of GLUT1 is composed of 488 amino acids in fish, 490 in chicken and 492 in human, bovine, rat and mouse with a molecular weight of approximately 54 kDa. It is the most conserved isoform and exhibits approximately 74-98% sequence identity among these species (Fig. 2A). The most divergent region is in the putative loop 1 where the glycosylation site is located. There is a unique proline-rich sequence in this region in bovine GLUT1 [31]. In addition, the C-terminal tail is most variable with the exception of the last 7 amino acids in fish.

### GLUT2 (SLC2A2)

GLUT2 is a low affinity transporter for glucose with a  $K_m$  of ~17 mM, galactose (~92 mM), mannose (~125 mM) and fructose (~76 mM), but is a high affinity transporter for glucosamine ( $K_m$  ~0.8 mM) [30, 32, 33]. Structurally, GLUT2 lacks the QLS motif at helix 7 which is thought to confer substrate specificity on the transporter and which may explain the high affinity for glucosamine [30]. GLUT2 expression occurs mainly in the kidney and intestinal absorptive epithelial cells where it is located in the basolateral membrane. In this location it participates in the release of absorbed or reabsorbed glucose [34, 35]. GLUT2 is also expressed in the liver; pancreas and brain. In hepatocytes, it is involved in the release of glucose synthesized by gluconeogenesis into the blood. In the pancreatic  $\beta$ -cell and hypothalamus, it provides glucose-sensing functions for insulin secretion as GLUT2-deficient mice display impaired glucose-stimulated insulin secretion [36-38]. The GLUT2 amino acid sequences displays 81% identity between the human, mouse and rat.

### GLUT3 (SLC2A3)

GLUT3 is considered to be a neuron-specific glucose transporter since its protein is mainly detected in the brain [39-41]. However, its mRNA is widely distributed in human tissues [40, 42] in contrast to its distribution in rodent and



bovine tissues [24, 43]. It transports glucose with high affinity ( $K_m = 1.4$  mM for 2-deoxy-glucose) and also transports galactose (8.5 mM), mannose, maltose, xylose and dehydroascorbic acid [33, 44].

**GLUT4 (SLC2A4)**

GLUT4 has been widely studied due to its role as the main insulin-sensitive member of this family and thus its role in diabetes. Its expression is highest in the insulin sensitive tissues including brown and white adipose tissue and skeletal and cardiac muscle. It has a  $K_m$  for glucose of approximately 5-6 mM, similar to GLUT1 and can also transport dehydroascorbic acid and glucosamine ( $K_m$  3.9 mM) [30, 45].

GLUT4 is a 509-510 amino acid protein with a molecular weight of approximately 55 kDa in human, bovine, rat and mouse. In these species it is highly conservative with 91-96% sequence identity (Fig. 2B). However, the fish GLUT4 protein shares only 67-68% sequence identity to other species. It has been shown that two sequence motifs in GLUT4, the dileucine motif in the C-terminus and the FQQI motif in the N-terminus (Fig. 2B), are crucial for its localization in an intracellular tubulo-vesicular compartment in a non-insulin stimulated condition [46]. Interestingly, both of these two motifs are not intact in fish. Under insulin stimulation, GLUT4 undergoes a rapid translocation from the intracellular location to the cell surface, resulting in a dramatic increase in cellular glucose transport activity [47]. In bovine muscle, the insulin-induced GLUT4 translocation to the

**A**

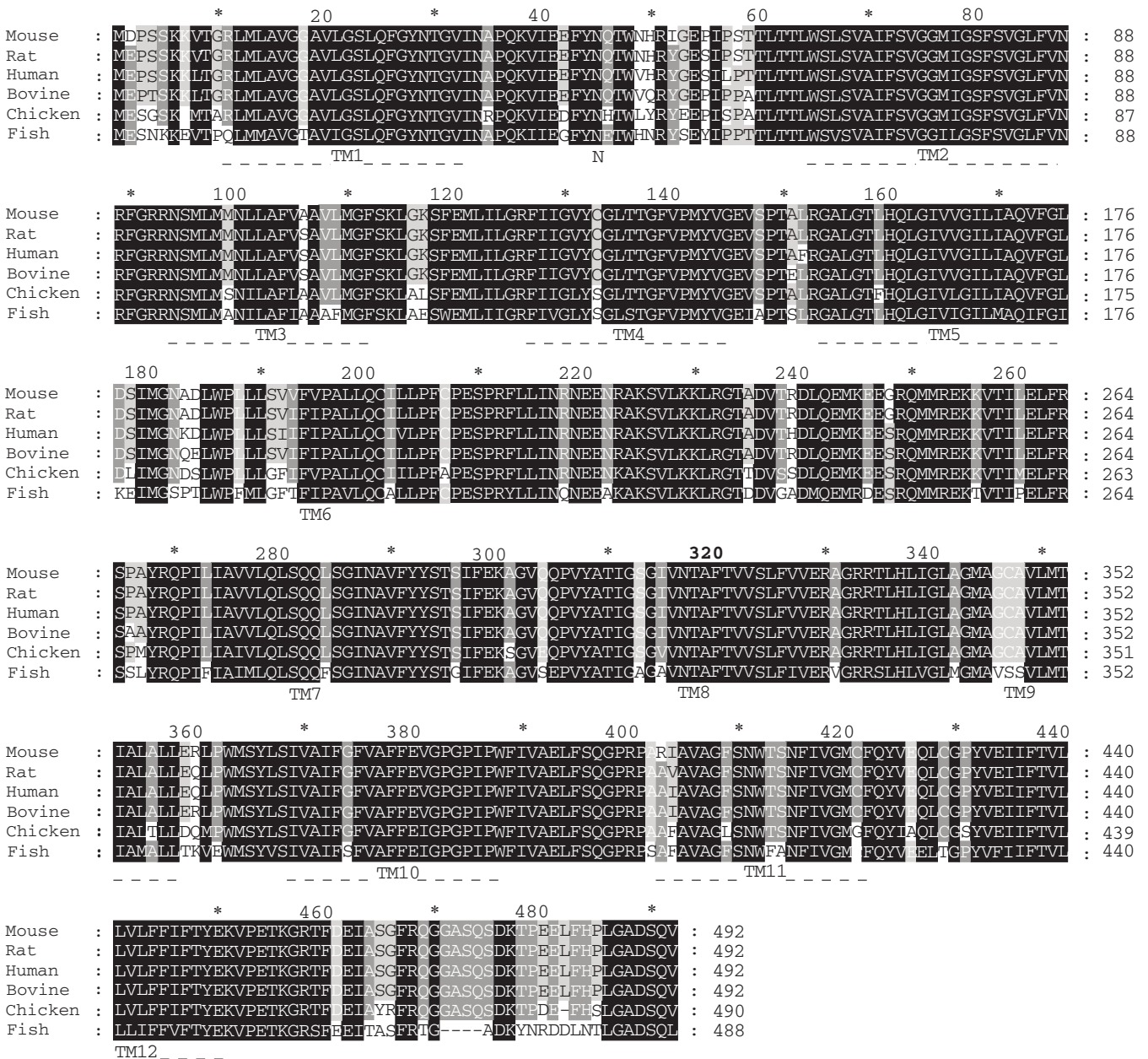

(Fig. 2) contd....

**B**

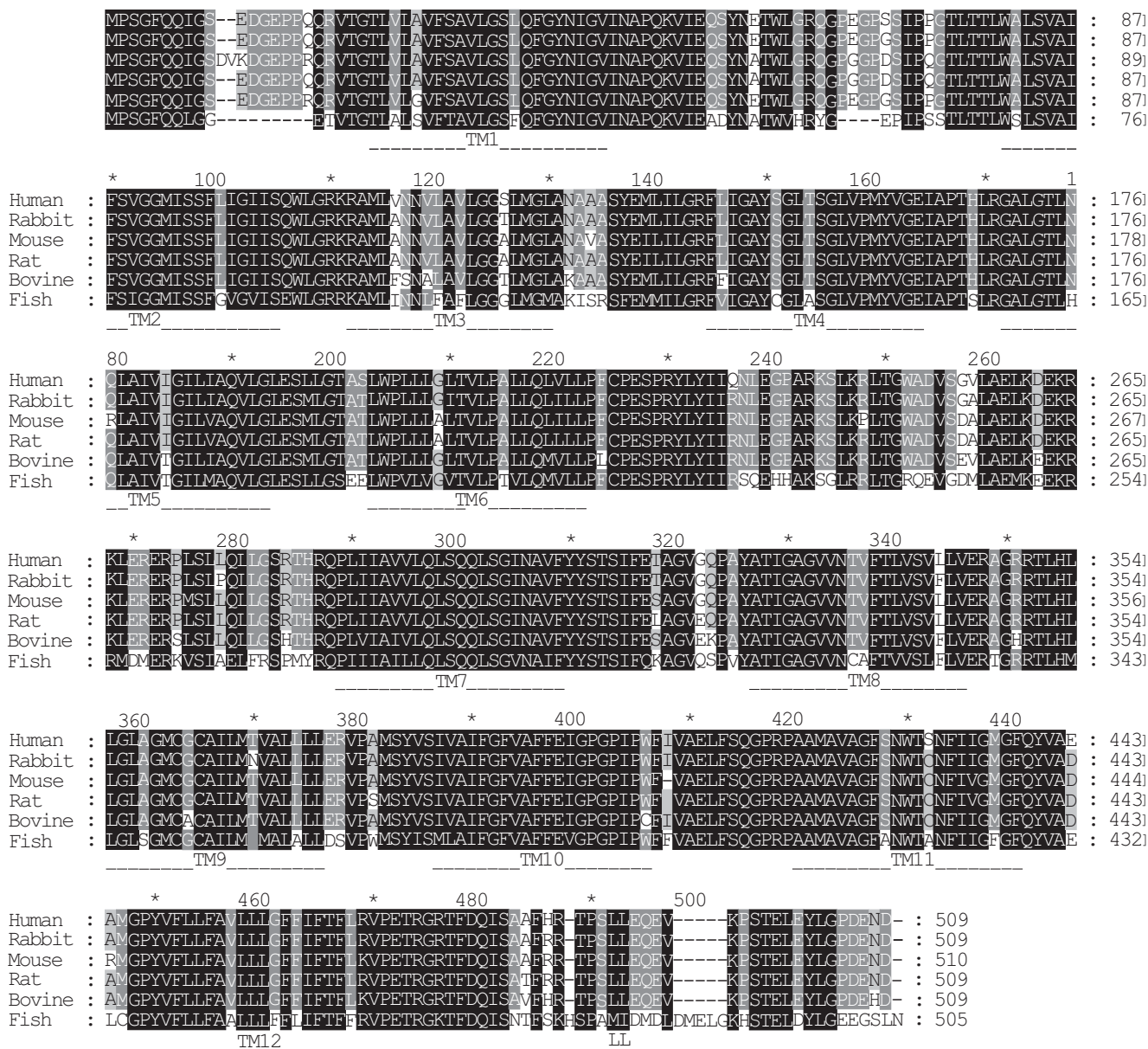

**Fig. (2).** Multiple sequence alignments of the deduced amino acid sequences of human, mouse, rat, rabbit, bovine, chicken and fish GLUT1 (A) and GLUT4 (B). The GenBank protein identification numbers of these transporters are NP\_006507.1 (human GLUT1), NP\_035530.1 (mouse GLUT1), NP\_620182.1 (rat GLUT1), NP\_777027.1 (bovine GLUT1), NP\_990540.1 (chicken GLUT1), ABA39726.1 (fish GLUT1), NP\_001033.1 (human GLUT4), NP\_033230.1 (mouse GLUT4), AAR04439.1 (rabbit GLUT4), NP\_036883.1 (rat GLUT4), NP\_777029.1 (bovine GLUT4), and AAM22227.1 (fish GLUT4). The alignment was performed with the CLUSTAL W program with open gap cost = 10 and gap extension cost = 0.2. Residues that are highlighted by black shading background represent absolutely conserved amino acids and the gray shading indicates four or more conserved residues at that position. Positions of presumed membrane-spanning helices (TM) (Joost and Thorens, 2001) are given by the numbered dashed lines at the bottom of the sequence alignments. In addition, in (B) the N-terminal FQQI and C-terminal dileucine motifs of GLUT4 are indicated.

plasma membrane is significantly lower than in porcine, which may explain the lower insulin sensitivity in adult ruminants compared with monogastric omnivores [48]. It has been speculated that the replacement of Asn<sup>508</sup> in the C-terminus of human and rodent GLUT4 by His<sup>508</sup> in bovine

GLUT4 may contribute to the impaired insulin stimulation of translocation [49].

GLUT4-null mice display retarded growth and decreased longevity, but maintain nearly normal glycaemia in either the

fasting or fed state [50]. These mice exhibit cardiac hypertrophy, severely reduced adipose tissue deposits and impaired insulin tolerance.

#### **GLUT5 (SLC2A5)**

In contrast to GLUT1-4, human and mouse GLUT5 exhibits no transport activity for glucose, but mediates fructose transport with a  $K_m$  of ~6 mM [51, 52]. In human, rat and mouse, GLUT5 is primarily expressed in the jejunal region of the small intestine and at lower levels in kidney, brain and a few other tissues [51-53]. In the small intestine, GLUT5 is localized to both the apical and basolateral membranes of absorptive epithelial cells [54, 55] and mediates fructose absorption from the intestinal lumen. In bovine, GLUT5 mRNA is most abundant in the kidney and liver [24], reflecting the metabolic difference between the ruminant and non-ruminant.

#### **GLUT6 (SLC2A6)**

Human GLUT6 was cloned from leucocytes and is composed of 507 amino acids [56]. Its mRNA is predominantly expressed in the brain, spleen and peripheral leucocytes. In COS-7 cells, the cDNA of human GLUT6 expresses a 46-kDa membrane protein which exhibits reconstitutable glucose transport activity [56]. In rat adipose cells, transiently expressed GLUT6 retains an intracellular compartment location in non-stimulated cells and mutation of the N-terminal dileucine motif leads to cell-surface expression of the protein. However, no translocation of GLUT6 can be stimulated by insulin, phorbol ester or hyperosmolarity [57].

#### **GLUT7 (SLC2A7)**

GLUT7 is the most recently cloned GLUT member. The human GLUT7 was cloned from a human intestinal cDNA library [58] and the encoded protein is comprised of 524 amino acids. It is most closely related to GLUT5 with 53% identity and has a high affinity for both glucose ( $K_m = 0.3$  mM) and fructose, but does not transport galactose, 2-deoxy-D-glucose and xylose [58]. The tissue distribution of GLUT7 mRNA is the small intestine, colon, testis and prostate [58]. In the small intestine, GLUT7 protein is predominantly distributed in the brush-border membrane of enterocytes. The Ile-314 residue in human GLUT7 has been shown to be essential for transport activity for fructose, but not for glucose [59].

#### **GLUT8 (SLC2A8)**

As with GLUT6, GLUT8 is a member of the Class III GLUT family whose members have a putative glycosylation site on loop 9 rather than on loop 1. It share some sequence homology to GLUT 1-4 (~25% identity), but is more closely related to hexose transporters present in plants and bacteria [60]. GLUT8 also differs from other GLUT's at the C-terminal cytoplasmic tail, which is quite short at 20 amino acids in length compared to 42-45 amino acids for GLUT1-5. This may be important for mediating its conformational changes that accompany glucose transport. GLUT8 contains a dileucine motif in the N-terminus which is believed to target the protein to an intracellular compartment since mutation of this motif induced both expression of GLUT8 at the

cell surface and also transport activity in *Xenopus* oocytes with a high-affinity for glucose ( $K_m \sim 2$  mM) [60]. However, induction of GLUT8 translocation by insulin, as observed in GLUT4, has been controversial. The transduction has been observed in blastocytes [61] but not in fat cells [57]. Northern analysis has revealed that expression of this isoform is predominantly in testes and at lower levels in almost all other tissues [60, 62]. It has thus been postulated to play a major role in the provision of glucose to mature spermatozoa. It has been shown that GLUT8 mRNA levels increase dramatically during late pregnancy to early lactation in bovine and mouse mammary gland, indicating a potential role in glucose uptake for milk synthesis in this tissue [62]. GLUT8 knock-out mice were recently reported to display normal embryonic and postnatal development and glucose homeostasis, but mild defects in hippocampal neurogenesis and cardiac function [63].

#### **GLUT9 (SLC2A9)**

The human GLUT9 gene encodes two isoforms through the use of alternative promoters. The major isoform GLUT9 is comprised of 540 amino acids [64] while the GLUT9 DeltaN isoform is comprised of 512 amino acids differing at the N-terminus [18]. In human, GLUT9 is expressed mainly in the kidney and liver, whereas GLUT9DeltaN is detected only in the kidney and placenta [18, 64]. In kidney, GLUT9 is localized to the proximal tubule of epithelial cells. GLUT9 exhibits glucose transport activity as demonstrated by 2-deoxy-D-glucose uptake in *Xenopus* oocytes [18]. At least three GLUT9 isoforms have also been cloned from mouse tissues which are shown to be up-regulated in diabetes [19].

#### **GLUT10 (SLC2A10)**

GLUT10, composed of 541 amino acids in humans, is a transporter protein with a very high affinity for both 2-deoxy-D-glucose ( $K_m \sim 0.3$  mM) and D-galactose [65]. It shares only 18-22% identity with human GLUT1-11, but 35% to GLUT12. Interestingly, GLUT10 does not have the PESPR motif in loop 6 present in all other GLUTs (Fig. 1A) and this may contribute to its high affinity to glucose. GLUT10 mRNA is expressed at highest levels in the liver and pancreas, but is also expressed in the heart, lung, brain, skeletal muscle and placenta [65, 66]. GLUT10 has received special interest because it is located at human chromosomal region 20q12-13.1, which has been linked to a susceptibility loci for Type 2 diabetes. However, polymorphisms of GLUT10 are not associated to Type II diabetes in Caucasian Americans [67], Danish [68] and Taiwanese populations [69], but GLUT10 deficiency has recently been found to be associated with human arterial tortuosity syndrome [70].

#### **GLUT11 (SLC2A11)**

GLUT11 is a member of the class II GLUT family and exhibits highest sequence similarity with the fructose transporter GLUT5 (about 42%) [71, 72]. In human, three isoforms of GLUT11 (GLUT11-A, GLUT11-B, and GLUT11-C) have been cloned, which differ only at their N-terminal sequences [20, 21, 72]. Because the 5' sequences flanking each exon 1 of these three variants exhibit promoter activity, it is believed that these isoforms are generated by alternative promoter use. These three isoforms are expressed in a tissue



specific manner: GLUT11A is present in heart, skeletal muscle and kidney; GLUT11B is present in placenta, adipose tissue, and kidney; and GLUT11C is present in adipose tissue, heart, skeletal muscle and pancreas [20, 21, 72]. However, these isoforms appear to have similar functional properties with transport activity for both fructose and glucose, but not for galactose [21, 71]. Interestingly, SLC2A11 gene is not present in the rat and mouse genome [21].

### GLUT12 (SLC2A12)

GLUT12 falls into the Class III GLUT family and contains a number of similar features to GLUT4 such as dileucine motifs at the both the N- and C- termini in similar locations to the GLUT4 FQQI and LL internalization motifs in human [73]. In *Xenopus laevis* oocytes, GLUT12 has been shown to have a preferential affinity for glucose over other hexoses [74]. In normal human adult tissues, GLUT12 expression appears to be restricted to insulin-sensitive skeletal muscle, heart and fat and is, thus, postulated to be another insulin-responsive glucose transporter [73]. However, GLUT12 mRNA is ubiquitously expressed in the lactating bovine tissues, most abundant in bovine spleen and skeletal muscle [75]. GLUT12 was originally cloned from the human breast cancer cell line, MCF-7 [73], and its expression is found to be stronger in ductal cell carcinoma *in situ* cells than in benign ducts of breast cancer tissues [76], indicating a possible role in glucose uptake in breast cancer tissue.

### HMIT (SLC2A13)

HMIT is a H<sup>+</sup>/myo-inositol co-transporter and exhibits a pH-dependent transport activity specific for myo-inositol in *Xenopus* oocytes (K<sub>m</sub> ~100 mM) [77]. No transport activity for glucose has been detected to date. It is predominantly expressed in the brain [77], where it is present in neuron intracellular vesicles and can be induced to move to the cell surface following cell depolarization, activation of protein kinase C or increased intracellular calcium concentrations [78].

### SGLT1 (SLC5A1)

In 1987, Wright and co-workers used a novel expression cloning strategy to isolate cDNA encoding the sodium-dependent glucose transporter expressed in the small intestinal mucosa [79]. They injected the poly(A)<sup>+</sup>-RNA from the rabbit intestine into *Xenopus laevis* oocytes and measured phlorizin-sensitive  $\alpha$ -methyl-D-glucopyranoside uptake into oocytes. A cDNA clone encoding a protein exhibiting all the properties of the small intestinal brush-border transporter was isolated by this approach and designated SGLT1. The deduced SGLT1 is a 662-amino acid polypeptide with a molecular weight of 73 kDa and shows no sequence homology to GLUT proteins. SGLT1 exhibits a high affinity for D-glucose (K<sub>m</sub> ~0.4) and galactose [80]. It is predominantly expressed in the brush border membrane of mature enterocytes in the small intestine and plays a major role in absorption of dietary D-glucose and D-galactose from the intestinal lumen [81, 82]. However, SGLT1 expression has been observed in many tissues in which glucose is believed to be taken up by the facilitative process, such as the mammary gland and liver [17]. It, thus, may be multifunctional, such as also functioning as a water cotransporter [83].

### SGLT2 (SLC5A2)

SGLT2 is a low-affinity glucose transporter. It transports  $\alpha$ -methyl-D-glucoside with an apparent K<sub>m</sub> of 2 mM, but cannot efficiently transport D-galactose and 3-O-methyl-D-glucose [84, 85]. SGLT2 is predominantly located in the S1 and S2 segments of renal convoluted proximal tubules in human and rat, and is presumed to be mainly responsible for the reabsorption of D-glucose from the glomerular filtrate [84-86]. This assumption is further supported by genetic evidence that homozygous and heterozygous nonsense mutations of SGLT2 are associated with autosomal recessive renal glycosuria in human patients [87, 88].

## ROLES OF GLUCOSE TRANSPORTERS IN DIFFERENT PHYSIOLOGICAL PROCESSES

### Glucose Absorption in the Small Intestine

Glucose availability to the tissues of monogastric species, including human, is mainly dependent on the supply, digestion, and absorption of dietary carbohydrate in their small intestine. Carbohydrate, mostly in the form of starches, is digested by salivary and pancreatic  $\alpha$ -amylases and intestinal brush border carbohydrases to free sugars, mainly D-glucose, D-galactose and D-fructose. The absorption of these free sugars from the small intestine is believed to be a two-step process [82]. The SGLT1 on the apical brush borders of intestinal epithelial cells actively accumulates D-glucose and D-galactose against their concentration gradients by coupling the transport of these sugars with the downward gradient transport of sodium. The sodium gradient is maintained by the active transport of sodium across the basolateral surface of the epithelial cells by the membrane-bound Na<sup>+</sup>/K<sup>+</sup>/ATPase. The absorption of D-fructose is a passive process mediated by the GLUT5. The accumulated sugars in enterocytes are subsequently released into the capillaries *via* the facilitated transporters, GLUT2 and GLUT5, localized on the basolateral surface of the cells. However, there is an increasing evidence showing that GLUT2 may also mediate a diffusive component of intestine glucose absorption in the brush-border membrane [89, 90]. Mutations of SGLT1 have been linked to a major defect in glucose and galactose absorption [91], but both a GLUT2-deficient patient [92] and GLUT2-null mice [93] displayed normal intestinal monosaccharide transport kinetics, suggesting the presence of a membrane traffic-based pathway in intestinal sugar absorption.

In ruminant species, the majority of carbohydrates are fermented into the volatile fatty acids by rumen microorganisms in rumen and negligible amounts of starch enter the small intestine. Concordant with this, SGLT1 expression is much lower in the ruminant small intestine compared to that in monogastric animals [94]. In addition, the highest expression of SGLT1 in bovine is observed in the mucosal tissues of the rumen and omasum, implying a role of glucose absorption by the forestomach in ruminants.

### Glucose Reabsorption in Kidney Proximal Convoluted Tubules

The kidneys play an essential role in maintenance and regulation of glucose homeostasis. In the course of a single

day, renal glomeruli generate about 180 L of filtrate in humans and about 180 g of D-glucose are filtered from plasma by the renal corpuscles. Normally, all of the filtered glucose is reabsorbed into blood by the proximal convoluted tubules. The mechanisms of glucose reabsorption across the tubule are considered to be similar to that in the small intestine, mediated by an active process in the brush-border membrane of the tubular epithelium and a facilitated process in the basolateral membrane. However, SGLT2, rather than SGLT1, plays a dominant role in the active process, supported by genetic evidence that homozygous and heterozygous non-sense mutations of SGLT2 are associated with autosomal recessive renal glycosuria in human patients [87, 88].

### Glucose Sensing and Insulin Secretion

In mammals, blood glucose levels are maintained within a narrow range by homeostatic mechanisms. Traditionally glucose levels are considered to be monitored by pancreatic  $\alpha$  and  $\beta$ -cells which release glucagon or insulin in response to the changes of blood glucose levels and regulate glucose uptake and utilization in peripheral tissues, mainly skeletal muscle and fat tissues. However, recent studies using different animal models with genetic modifications of glucose transport in various tissues have suggested that glucose sensing is not restricted to the pancreatic cells, but also provided by hepatoportal vein, central neurons and glial cells and even tissues such as muscle and adipose [95-98] and that the glucose sensing in these tissues can be modulated by other nutrients, in particular fatty acids [99], hormones and peptides [98]. GLUT2 has been found to play an essential role in glucose sensing in different tissues [37, 95, 100, 101]. GLUT2-null mice are hyperglycemic, hypoinsulinemic, hyperglucagonemic, and glycosuric and die within the first 3 weeks of life [36, 102]. Reexpressing GLUT1 or GLUT2 in beta-cells of GLUT2-null mice results in nearly normal glucose-stimulated insulin secretion and lethality [103] and reexpression of GLUT2 in glial cells restored glucagon secretion following glucoprivation [101]. GLUT2 is the major glucose transporter for the islet  $\beta$ -cells. Since GLUT2 is a high capacity transporter, the intracellular glucose concentration is directly proportional to the extracellular glucose levels. It is thought that increased intracellular glucose results in increase in the ATP/ADP ratio which can close ATP-sensitive potassium channels, depolarize  $\beta$ -cells and lead to insulin secretion [104].

### Glucose Uptake for Milk Synthesis in the Mammary Gland

Glucose is the primary precursor of lactose, the major solid component and osmolarity regulator of milk. Glucose uptake in the mammary gland increases dramatically to meet the requirement of milk synthesis. For example, a bovine producing 40 kg of milk per day requires that the mammary gland takes up about 3 kg of glucose daily and mammary gland uptake can account for as much as 60-85% of the total glucose that enters the blood (for review, see [105]). The increased glucose demand in the mammary gland for lactation is accomplished by increased glucose transporter expression in this tissue from pregnancy to early lactation. Multiple glucose transporter isoforms have been detected in the mammary tissue, including GLUT1, 8, 12 and SGLT1.

The mRNA expression of these transporters increases 5- to 10 fold for GLUT8, 12 and SGLT1 and hundred fold for GLUT1 from late pregnancy to early lactation [62, 105].

## REGULATION OF GLUCOSE TRANSPORTERS

### Hormonal Regulation

GLUT4 is the major insulin-responsive glucose transporter and is largely responsible for insulin-stimulated glucose transport into muscle and adipose tissues [96, 106, 107]. It is sequestered to intracellular vesicles in the absence of insulin and translocated to the plasma membrane upon insulin stimulation, resulting in increased glucose uptake [108]. This increased GLUT4-mediated glucose transport plays a rate-limiting role in glucose utilization in these tissues [109, 110]. GLUT4 proteins are removed from the plasma membrane by endocytosis and recycled back to their intracellular storage compartment when insulin stimulation is withdrawn. The insulin-stimulated GLUT4 translocation is achieved through multiple highly organized membrane trafficking events, orchestrated by insulin receptor signals. Several key molecules linking insulin receptor signals and GLUT4 translocation have been recently identified [108, 111-115]. Emerging evidence supports two independent insulin receptor signaling pathways, one leading to the activation of phosphatidylinositol (PI) 3-kinase/Akt/AS160 [47, 116] and the other to the activation of the Rho family small GTP-binding protein TC10 [117, 118]. Both pathways involve actin remodeling beneath the plasma membrane and around endomembranes [119]. In addition to the regulation of GLUT4 translocation, insulin also increases GLUT4 expression in adipocytes in the presence of and synergistically acts with glucocorticoids [120, 121].

The developmental regulation of the glucose transporters prior to and after the beginning of lactation indicates that their expression and function is likely to be regulated by hormonal changes around the onset of lactation. Indeed, mouse mammary epithelial cells have been shown to increase their intracellular GLUT1 levels approximately 15-fold in response to prolactin and hydrocortisone [122]. The galactopoietic effects of exogenous growth hormone to the lactating cows are associated with dramatically decreased GLUT4 expression in peripheral adipose and muscle tissues, consistent with regulation of nutrient partitioning by this hormone to shift more glucose from these tissues to the mammary gland to support increased milk synthesis [123].

GLUT8 is predominantly expressed in testes and plays a role in glucose supply to mature spermatozoa. The expression of GLUT8 in human testes is seen to be fully suppressed by a high dose of estrogen [124]. In rat, GLUT8 mRNA is present in testes of adult and pubertal rats, but not in prepubertal rats, also suggesting that GLUT8 expression is gonadotropin-dependent [124]. However, the rapid increase of GLUT8 expression in the mammary gland and rise of blood estrogen levels during the onset of lactation indicate that GLUT8 expression is not suppressed by estrogen in the mammary tissue [62].

Thyroid hormones play a key role in regulation of tissue metabolic rate. Their effects on glucose transporter expression in tissues contribute to this regulation. It has been

shown that T3 strongly regulates GLUT1 and GLUT3 mRNA in cerebral cortex of hypothyroid rat neonates [125], increase GLUT2 in liver [126], and increases GLUT4 expression in differentiating rat brown adipocytes [127] and in skeletal muscle [128].

### Transcriptional Regulation

In the rat GLUT1 promoter, a 44-bp GC-rich segment, located at -104 to -61, is necessary for basal transcription of the GLUT1 gene and the Sp1 site located within this segment may be responsible for this activity and for the promoter response to hyperosmolarity [129, 130]. A novel muscle-specific cis element has also been identified at -46/-37 of the GLUT1 promoter [131]. Mutation of this site impairs transcriptional activity of the GLUT1 promoter and its induction by Sp1, cAMP or serum specifically in skeletal or cardiac muscle cells. A C-rich element at -67/-60 (C8 box) was identified to mediate inhibition of the promoter in a proliferation-dependent manner [132]. The tumor suppressor p53 also binds to the GLUT1 promoter and represses GLUT1 transcription in a tissue-specific manner [133]. In addition, two enhancer elements have been identified to be responsive to serum, growth factor, insulin, and oncogenes in the mouse GLUT1 gene, one at -2.7 kb and another in the second intron [134, 135]. A ten nucleotide cis element was also identified in the 3'-untranslated region of the GLUT1 mRNA and plays a role in its stabilization [136].

GLUT2 has highly specific tissue expression. It has been shown that the proximal 338 bp of the murine GLUT2 promoter contain cis-elements which can be bound by islet-specific trans-acting factors required for the islet-specific expression of GLUT2 [137, 138]. In human, 227 bp of the 5' flanking region of the GLUT2 gene contain promoter activity and the region of -132/-87 contains multiple binding sites for hepatocyte nuclear factor 1 (HNF1) and HNF3 and is responsible for tissue specific expression of GLUT2 in hepatocytes [139]. The sterol-regulatory-element-binding protein (SREBP)-1c binds to the -84/-76 region of the GLUT2 promoter and mediates glucose-stimulated GLUT2 gene expression in hepatocytes [140]. Other transcription factors that have been identified which are involved in activation of GLUT2 transcription include the homeodomain protein PDX-1 (binding to a repeat of a TAAT motif) [141], the CCAAT/enhancer binding proteins, C/EBPalpha and C/EBPbeta (binding to -375/-356 and -500/-471 regions in rat) [142], peroxisomal proliferator-activated receptor (PPAR)-gamma and retinoid X receptor (RXR)-alpha (binding to -89/-68 region in rat) [143].

A transgenic study has indicated that the human GLUT4 gene requires 1154 bp of the 5'-flanking region to direct the full extent of tissue-specific and insulin-dependent regulation and 730 bp contain skeletal muscle-specific DNA elements [144]. The regulation of the human GLUT4 promoter requires cooperative function of two distinct regulatory elements, domain 1 and the myocyte enhancer factor 2 (MEF2)-binding domain [145, 146]. These two domains are bound by the GLUT4 enhancer factor (GEF) and MEF2A and MEF2D, respectively, and the protein-protein interactions of these proteins are involved in GLUT4 transcriptional activation [147, 148]. The interactions of MEF2 with MyoD myo-

genic proteins and the thyroid hormone receptor (TRalpha1) have also been shown to be required for full activation of GLUT4 transcription [149]. The human GLUT4 promoter contains a putative sterol response element in the region between bases -109 and -100 and Sp1 binds to a site adjacent to this element to play an additive role in SREBP-1c mediated GLUT4 gene upregulation in adipose tissue [150]. The promoter of GLUT4 gene can be repressed by p53 and the -66/+163 bp region of the promoter region is necessary and sufficient for this repression [133]. The C/EBPalpha mediates a synergistic effect of insulin and dexamethasone on GLUT4 gene expression in foetal brown adipocytes [121]. Additional factors involved in GLUT4 gene transcription in skeletal muscle include Kruppel-like factor KLF15, NF1, Olf-1/Early B cell factor and GEF/HDBP1 [151].

Analysis of the promoter region of mouse GLUT8 gene has identified that 381 bp of 5' flanking sequence is critical for its promoter activity [152]. This region contains a CAAT box and two highly conserved putative binding sites for SRY and NF1. When these sites were deleted, transcriptional activity was reduced by approximately 50%. SRY is a Y-chromosomal gene that triggers development of the male phenotype in mammalian embryos and is necessary for the development of Sertoli cells, Leydig cells and the testis [153, 154]. The putative activation of GLUT8 by SRY may explain the predominant expression of GLUT8 in testes.

The human GLUT10 gene promoter has been recently characterized [155]. Two alternative transcription start sites were identified in different tissues and cells. The basal promoter is located in the -70/-14 region of the 5'-flanking sequence and contains consensus binding sites for Sp and AP2alpha which are required for maximal activation of the basal promoter.

## PATHOPHYSIOLOGICAL ROLES OF GLUCOSE TRANSPORTERS

### Diabetes

Type 2 diabetes (non-insulin dependent diabetes mellitus, NIDDM) is a rapid growing global pandemic. The  $\beta$  cells of the pancreas of Type 2 diabetes patients are unable to secrete sufficient insulin to compensate for insulin resistance and thus result in impaired glucose homeostasis. Aberrant insulin signalling and glucose metabolism in diabetic patients may arise from genetic defects and an altered metabolic milieu. In these patients, the insulin-stimulated glucose disposal mediated by the translocation of GLUT4 in muscle and adipose tissue is diminished, largely contributing to insulin resistance. This defect appears to be a result of reduced IRS (insulin-receptor substrate)-1-associated PI3-kinase activity resulted from intracellular lipid-induced inhibition of IRS-1 tyrosine phosphorylation, impaired phosphorylation of Akt and its substrate AS160 and inefficient coupling of activation of Akt/AS160 signalling with GLUT4 trafficking and glucose transport activity in skeletal muscle [156-159]. GLUT4 expression is also down-regulated in adipocytes, but not in skeletal muscle in insulin-resistant human and rodents [160]. Overexpression of GLUT4 in the adipose tissue of mice lacking GLUT4 selectively in muscle reverses whole body insulin resistance and diabetes [161].

## Cancer

Malignant cells have accelerated metabolism, high glucose requirements, and increased glucose uptake in order to meet their increased energy requirement for rapid growth. Many cancers and cancer cell lines over-express the GLUT family members, in particular GLUT1, which are expressed in the respective tissues of origin under normal conditions and often induce expression of GLUTs which would not be expressed in normal conditions. Overexpression of GLUT1 has been widely seen in many cancer tissues and cells, including carcinoma of pancreas [162, 163], cervix [164], esophagus [165], lung [166], liver [167], thyroid gland [168], ovary [169-171], juvenile hemangiomas [172], stomach [173], prostate [174] and breast [175, 176]. Overexpression of GLUT12 has been observed in breast tumors [76]. GLUT5 has been found to be expressed in malignant breast cells but not in normal breast cells [177-179] and blocking of GLUT5 expression has been shown to reduce the growth of malignant cancerous cells [178].

## CONCLUSION

Multiple glucose transporter proteins are present in mammalian cells and all mammalian tissues express more than one of these transporters in order to efficiently obtain sufficient glucose from the extracellular fluid for cell metabolism. Each glucose transporter has different transport kinetics and regulatory properties and plays specific roles in maintenance of whole body glucose homeostasis. Aberrant expression and regulation of these proteins can lead to or contribute to various pathological conditions, such as diabetes, obesity and cancer. A more thorough understanding of this group of proteins will provide useful information in combating these diseases.

## REFERENCES

- [1] Widdas, W.F. Old and new concepts of the membrane transport for glucose in cells. *Biochim. Biophys. Acta* **1988**, *947*: 385-404.
- [2] Joost, H.G., Bell, G.I., West, J.D., Birnbaum, M.J., Charron, M.J., Chen, Y., Doege, H., James, D.E., Lodish, H.F., Moley, K.H., Moley, J.F., Mueckler, M.; Rogers, S., Schurmann, A., Seino, S., Thorens, B. Nomenclature of the GLUT/SLC2A family of Sugar/Polyol transport facilitators. *Am. J. Physiol. Endocrinol. Metab.* **2002**, *282*: E974-6.
- [3] Wright, E.M., Turk, E.M. The sodium/glucose cotransport family SLC5. *Pflugers Arch.* **2004**, *447*: 510-8.
- [4] Joost H.G., Thorens, B. The extended GLUT-family of sugar/polyol transport facilitators: nomenclature, sequence characteristics, and potential function of its novel members (review). *Mol. Membr. Biol.* **2001**, *18*: 247-56.
- [5] Garcia, J.C., Strube, M., Leingang, K., Keller, K., Mueckler, M.M. Amino acid substitutions at tryptophan 388 and tryptophan 412 of the HepG2 (Glut1) glucose transporter inhibit transport activity and targeting to the plasma membrane in *Xenopus* oocytes. *J. Biol. Chem.* **1992**, *267*: 7770-6.
- [6] Schurmann, A., Keller, K., Monden, I., Brown, F.M., Wandel, S., Shanahan, M.F., Joost, H.G. Glucose transport activity and photolabelling with 3-[125I]iodo-4-azidophenethylamido-7-O-succinyldeacetyl (IAPS)-forskolin of two mutants at tryptophan-388 and -412 of the glucose transporter GLUT1: dissociation of the binding domains of forskolin and glucose. *Biochem. J.* **1993**, *290*: 497-501.
- [7] Mori, H., Hashiramoto, M., Clark, A.E., Yang, J., Muraoka, A., Tamori, Y., Kasuga, M., Holman, G.D. Substitution of tyrosine 293 of GLUT1 locks the transporter into an outward facing conformation. *J. Biol. Chem.* **1994**, *269*: 11578-83.
- [8] Tamori, Y., Hashiramoto, M., Clark, A.E., Mori, H., Muraoka, A., Kadowaki, T., Holman, G.D., Kasuga, M. Substitution at Pro385 of GLUT1 perturbs the glucose transport function by reducing conformational flexibility. *J. Biol. Chem.* **1994**, *269*: 2982-6.
- [9] Schurmann, A., Doege, H., Ohnimus, H., Monser, V., Buchs, A., Joost, H.G. Role of conserved arginine and glutamate residues on the cytosolic surface of glucose transporters for transporter function. *Biochemistry* **1997**, *36*: 12897-902.
- [10] Muraoka, A., Hashiramoto, M., Clark, A.E., Edwards, L.C., Sakura, H., Kadowaki, T., Holman, G.D., Kasuga, M. Analysis of the structural features of the C-terminus of GLUT1 that are required for transport catalytic activity. *Biochem. J.* **1995**, *311*: 699-704.
- [11] Asano, T., Katagiri, H., Takata, K., Lin, J.L., Ishihara, H., Inukai, K., Tsukuda, K., Kikuchi, M., Hirano, H., Yazaki, Y. The role of N-glycosylation of GLUT1 for glucose transport activity. *J. Biol. Chem.* **1991**, *266*: 24632-6.
- [12] Asano, T., Takata, K., Katagiri, H., Ishihara, H., Inukai, K., Anai, M., Hirano, H., Yazaki, Y., Oka, Y. The role of N-glycosylation in the targeting and stability of GLUT1 glucose transporter. *FEBS Lett.* **1993**, *324*: 258-61.
- [13] Samih, N., Hovsepian, S., Aouani, A., Lombardo, D., Fayet, G. Glut-1 translocation in FRTL-5 thyroid cells: role of phosphatidylinositol 3-kinase and N-glycosylation. *Endocrinology* **2000**, *141*: 4146-55.
- [14] Samih, N., Hovsepian, S., Notel, F., Prorok, M., Zattara-Cannoni, H., Mathieu, S., Lombardo, D., Fayet, G., El-Battari, A. The impact of N- and O-glycosylation on the functions of Glut-1 transporter in human thyroid anaplastic cells. *Biochim. Biophys. Acta* **2003**, *1621*: 92-101.
- [15] Ohtsubo, K., Takamatsu, S., Minowa, M.T., Yoshida, A., Takeuchi, M., Marth, J.D. Dietary and genetic control of glucose transporter 2 glycosylation promotes insulin secretion in suppressing diabetes. *Cell* **2005**, *123*: 1307-21.
- [16] Zhao, F.-Q., McFadden, T.B., Wall, E.H., Dong, B., Zheng, Y.C. Cloning and expression of bovine sodium/glucose co transporter SGLT2. *J. Dairy Sci.* **2005**, *88*: 2738-48.
- [17] Zhao, F.-Q., Zheng, Y.C., Wall, E.H., McFadden, T.B. Cloning and expression of bovine sodium/glucose cotransporters. *J. Dairy Sci.* **2005**, *88*: 182-94.
- [18] Augustin, R., Carayannopoulos, M.O., Dowd, L.O., Phay, J.E., Moley, J.F., Moley, K.H. Identification and characterization of human glucose transporter-like protein-9 (GLUT9). *J. Biol. Chem.* **2004**, *279*: 16229-36.
- [19] Keembiyehetty, C., Augustin, R., Carayannopoulos, M.O., Steer, S., Manolescu, A., Cheeseman, C.I., Moley, K.H. Mouse glucose transporter 9 splice variants are expressed in adult liver and kidney and are up-regulated in diabetes. *Mol. Endocrinol.* **2006**, *20*: 686-97.
- [20] Wu, X., Li, W., Sharma, V., Godzik, A., Freeze, H.H. Cloning and characterization of glucose transporter 11, a novel sugar transporter that is alternatively spliced in various tissues. *Mol. Genet. Metab.* **2002**, *76*: 37-45.
- [21] Scheepers, A., Schmidt, S., Manolescu, A., Cheeseman, C.I., Bell, A., Zahn, C., Joost, H.G., Schurmann, A. Characterization of the human SLC2A11 (GLUT11) gene: alternative promoter usage, function, expression, and subcellular distribution of three isoforms, and lack of mouse orthologue. *Mol. Membr. Biol.* **2005**, *22*: 339-51.
- [22] Hogan, A., Heyner, S., Charron, M.J., Copeland, N.G., Gilbert, D.J., Jenkins, N.A., Thorens, B., Schultz, G.A. Glucose transporter gene expression in early mouse embryos. *Development* **1991**, *113*: 363-72.
- [23] Takata, K., Kasahara, T., Kasahara, M., Ezaki, O., Hirano, H. Erythrocyte/HepG2-type glucose transporter is concentrated in cells of blood-tissue barriers. *Biochem. Biophys. Res. Commun.* **1990**, *173*: 67-73.
- [24] Zhao, F.-Q., Glimm, D.R., Kennelly, J.J. Distribution of mammalian facultative glucose transporter messenger RNA in bovine tissues. *Int. J. Biochem.* **1993**, *25*: 1897-903.
- [25] Jensen, P.J., Gitlin, J.D., Carayannopoulos, M.O. GLUT1 deficiency links nutrient availability and apoptosis during embryonic development. *J. Biol. Chem.* **2006**, *281*: 13382-7.
- [26] Marette, A., Richardson, J.M., Ramlal, T., Balon, T.W., Vranic, M., Pessin, J.E., Klip, A. Abundance, localization, and insulin-induced translocation of glucose transporters in red and white muscle. *Am. J. Physiol.* **1992**, *263*: C443-52.
- [27] Keller, K., Strube, M., Mueckler, M. Functional expression of the human HepG2 and rat adipocyte glucose transporters in *Xenopus*

- oocytes. Comparison of kinetic parameters. *J. Biol. Chem.* **1989**, *264*: 18884-9.
- [28] Gould, G.W., Lienhard, G.E. Expression of a functional glucose transporter in *Xenopus* oocytes. *Biochemistry* **1989**, *28*: 9447-52.
- [29] Vera, J.C., Rosen, O.M. Functional expression of mammalian glucose transporters in *Xenopus laevis* oocytes: evidence for cell-dependent insulin sensitivity. *Mol. Cell. Biol.* **1989**, *9*: 4187-95.
- [30] Uldry, M., Ibberson, M., Hosokawa, M., Thorens, B. GLUT2 is a high affinity glucosamine transporter. *FEBS Letts.* **2002**, *524*: 199-203.
- [31] Boado, R.J., Pardridge, W.M. Molecular cloning of the bovine blood-brain barrier glucose transporter cDNA and demonstration of phylogenetic conservation of the 5' untranslated region. *Mol. Cell. Neurosci.* **1990**, *1*: 224-32.
- [32] Johnson, J.H., Newgard, C.B., Milburn, J.L., Lodish, H.F., Thorens, B. The high Km glucose transporter of islets of Langerhans is functionally similar to the low affinity transporter of liver and has an identical primary sequence. *J. Biol. Chem.* **1990**, *265*: 6548-51.
- [33] Colville C.A., Seatter, M.J., Jess, T.J., Gould, G.W., Thomas, H.M. Kinetic analysis of the liver-type (GLUT2) and brain-type (GLUT3) glucose transporters in *Xenopus* oocytes: substrate specificities and effects of transport inhibitors. *Biochem. J.* **1993**, *290*: 701-6.
- [34] Wright E.M., Turk, E.M. The sodium glucose cotransporter family SLC5. *Pflugers Arch.* **2003**, *447*: 813-15.
- [35] Kellett, G.L., Brot-Laroche, E. Apical GLUT2: a major pathway of intestinal sugar absorption. *Diabetes* **2005**, *54*: 3056-62.
- [36] Guillam, M.T., Hummler, E., Schaerer, E., Yeh, J.I., Birnbaum, M.J., Beermann, F., Schmidt, A., Deriaz, N., Thorens, B., Wu, J.Y. Early diabetes and abnormal postnatal pancreatic islet development in mice lacking Glut-2. *Nat. Genet.* **1997**, *17*: 327-30.
- [37] Burcelin, R., Thorens, B. Evidence that extrapancreatic GLUT2-dependent glucose sensors control glucagon secretion. *Diabetes* **2001**, *50*: 1282-9.
- [38] Bady, I., Marty, N., Dallaporta, M., Emery, M., Gyger, J., Tarussio, D., Foretz, M., Thorens, B. Evidence from glut2-null mice that glucose is a critical physiological regulator of feeding. *Diabetes* **2006**, *55*: 988-95.
- [39] Shepherd, P.R., Gould, G.W., Colville, C.A., McCoid, S.C., Gibbs, E.M., Kahn, B.B. Distribution of GLUT3 glucose transporter protein in human tissues. *Biochem. Biophys. Res. Commun.* **1992**, *188*: 149-54.
- [40] Haber, R.S., Weinstein, S.P., O'Boyle, E., Morgello, S. Tissue distribution of the human GLUT3 glucose transporter. *Endocrinology* **1993**, *132*: 2538-43.
- [41] McCall, A.L., Van Bueren, A.M., Moholt-Siebert, M., Cherry, N.J., Woodward, W.R. Immunohistochemical localization of the neuron-specific glucose transporter (GLUT3) to neuropil in adult rat brain. *Brain Res.* **1994**, *659*: 292-7.
- [42] Burant, C.F., Sivitz, W.I., Fukumoto, H., Kayano, T., Nagamatsu, S., Seino, S., Pessin, J.E., Bell, G.I. Mammalian glucose transporters: structure and molecular regulation. *Recent Prog. Horm. Res.* **1991**, *47*: 349-87.
- [43] Yano, H., Seino, Y., Inagaki, N., Hinokio, Y., Yamamoto, T., Yasuda, K., Masuda, K., Someya, Y., Imura, H. Tissue distribution and species difference of the brain type glucose transporter (GLUT3). *Biochem. Biophys. Res. Commun.* **1991**, *174*: 470-7.
- [44] Kayano, T., Fukumoto, H., Eddy, R.L., Fan, Y.S., Byers, M.G., Shows, T.B., Bell, G.I. Evidence for a family of human glucose transporter-like proteins. Sequence and gene localization of a protein expressed in fetal skeletal muscle and other tissues. *J. Biol. Chem.* **1988**, *263*: 15245-8.
- [45] Kasahara, T., Kasahara, M. Characterization of the rat Glut4 glucose transporter expressed in the yeast *Saccharomyces cerevisiae*: comparison with the Glut1 glucose transporter. *Biochim. Biophys. Acta* **1997**, *1324*: 111-9.
- [46] Al-Hasani, H., Kunamneni, R., Dawson, K., Hinck, C.S., Muller-Wieland, D., Cushman, S.W. Roles of the N- and C-termini of GLUT4 in endocytosis. *J. Cell. Sci.* **2002**, *115*: 131-40.
- [47] Gonzalez, E., McGraw, T.E. Insulin signaling diverges into Akt-dependent and -independent signals to regulate the recruitment/docking and the fusion of GLUT4 vesicles to the plasma membrane. *Mol. Biol. Cell.* **2006**, *17*: 4484-93.
- [48] Duhlmeier, R., Hacker, A., Widdel, W., Von Engelhardt W., Sallmann, H.P. Mechanisms of insulin-dependent glucose transport into porcine and bovine skeletal muscle. *Am. J. Physiol. Regul. Integr. Comp. Physiol.* **2005**, *289*: R187-97.
- [49] Abe, H., Morimatsu, M., Nikami, H., Miyashige, T., Saito, M. Molecular cloning and mRNA expression of the bovine insulin-responsive glucose transporter (GLUT4). *J. Anim. Sci.* **1997**, *75*: 182-8.
- [50] Katz, E.B., Stenbit, A.E., Hatton, K., DePinho, R., Charron, M.J. Cardiac and adipose tissue abnormalities but not diabetes in mice deficient in GLUT4. *Nature* **1995**, *377*: 151-5.
- [51] Burant, C.F., Takeda, J., Brot-Laroche, E., Bell, G.I., Davidson, N.O. Fructose transporter in human spermatozoa and small intestine is GLUT5. *J. Biol. Chem.* **1992**, *267*: 14523-6.
- [52] Corpe, C.P., Bovelander, F.J., Munoz, C.M., Hoekstra, J.H., Simpson, I.A., Kwon, O., Levine, M., Burant, C.F. Cloning and functional characterization of the mouse fructose transporter, GLUT5. *Biochim. Biophys. Acta* **2002**, *1576*: 191-7.
- [53] Rand, E.B., Depaoli, A.M., Davidson, N.O., Bell, G.I., Burant, C.F. Sequence, tissue distribution, and functional characterization of the rat fructose transporter GLUT5. *Am. J. Physiol.* **1993**, *264*: G1169-76.
- [54] Davidson, N.O., Hausman, A.M., Ifkovits, C.A., Buse, J.B., Gould, G.W., Burant, C.F., Bell, G.I. Human intestinal glucose transporter expression and localization of GLUT5. *Am. J. Physiol.* **1992**, *262*: C795-800.
- [55] Blakemore, S.J., Aledo, J.C., James, J., Campbell, F.C., Lucocq, J.M., Hundal, H.S. The GLUT5 hexose transporter is also localized to the basolateral membrane of the human jejunum. *Biochem. J.* **1995**, *309*: 7-12. Erratum in: *Biochem. J.* **1995**, *310*: 1055.
- [56] Doege, H., Bocianski, A., Joost, H.G., Schurmann, A. Activity and genomic organization of human glucose transporter 9 (GLUT9), a novel member of the family of sugar-transport facilitators predominantly expressed in brain and leucocytes. *Biochem. J.* **2000**, *350*: 771-6.
- [57] Lisinski, I., Schurmann, A., Joost, H.G., Cushman, S.W., Al-Hasani, H. Targeting of GLUT6 (formerly GLUT9) and GLUT8 in rat adipose cells. *Biochem. J.* **2001**, *358*: 517-22.
- [58] Li, Q., Manolescu, A., Ritzel, M., Yao, S., Slugoski, M., Young, J.D., Chen, X.Z., Cheeseman, C.I. Cloning and functional characterization of the human GLUT7 isoform SLC2A7 from the small intestine. *Am. J. Physiol. Gastrointest. Liver Physiol.* **2004**, *287*: G236-42.
- [59] Manolescu, A., Salas-Burgos, A.M., Fischberg, J., Cheeseman, C.I. Identification of a hydrophobic residue as a key determinant of fructose transport by the facilitative hexose transporter SLC2A7 (GLUT7). *J. Biol. Chem.* **2005**, *280*: 42978-83.
- [60] Ibberson, M., Uldry, M., Thorens, B. GLUTX1, a novel mammalian glucose transporter expressed in the central nervous system and insulin-sensitive tissues. *J. Biol. Chem.* **2000**, *275*: 4607-12.
- [61] Carayannopoulos, M.O., Chi, M.M., Cui, Y., Pingsterhaus, J.M., McKnight, R.A., Mueckler, M., Devaskar, S.U., Moley, K.H. GLUT8 is a glucose transporter responsible for insulin-stimulated glucose uptake in the blastocyst. *Proc. Natl. Acad. Sci. USA* **2000**, *97*: 7313-8.
- [62] Zhao, F.-Q., Miller, P.J., Wall, E.H., Zheng, Y.C., Neville, M.C., McFadden, T.B. Bovine glucose transporter GLUT8: cloning, expression, and developmental regulation in mammary gland. *Biochim. Biophys. Acta* **2004**, *1680*: 103-13.
- [63] Membrez, M., Hummler, E., Beermann, F., Haefliger, J.A., Savioz, R., Pedrazzini, T., Thorens, B. GLUT8 is dispensable for embryonic development but influences hippocampal neurogenesis and heart function. *Mol. Cell. Biol.* **2006**, *26*: 4268-76.
- [64] Phay, J.E., Hussain, H.B., Moley, J.F. Cloning and expression analysis of a novel member of the facilitative glucose transporter family, SLC2A9 (GLUT9). *Genomics* **2000**, *66*: 217-20.
- [65] Dawson, P.A., Mychaleckyj, J.C., Fossey, S.C., Mihic, S.J., Craddock, A.L., Bowden, D.W. Sequence and functional analysis of GLUT10: a glucose transporter in the Type 2 diabetes-linked region of chromosome 20q12-13.1. *Mol. Genet. Metab.* **2001**, *74*: 186-99.
- [66] McVie-Wylie, A.J., Lamson, D.R., Chen, Y.T. Molecular cloning of a novel member of the GLUT family of transporters, SLC2A10 (GLUT10), localized on chromosome 20q13.1: A candidate gene for NIDDM susceptibility. *Genomics* **2001**, *72*: 113-7.
- [67] Bento J.L., Bowden, D.W., Mychaleckyj, J.C., Hirakawa, S., Rich, S.S., Freedman, B.I., Segade, F. Genetic analysis of the GLUT10



- glucose transporter (SLC2A10) polymorphisms in Caucasian American type 2 diabetes. *BMC Med. Genet.* **2005**, *6*: 42.
- [68] Rose, C.S., Andersen, G., Hamid, Y.H., Glumer, C., Drivsholm, T., Borch-Johnsen, K., Jorgensen, T., Pedersen, O., Hansen, T. Studies of relationships between the GLUT10 Ala206Thr polymorphism and impaired insulin secretion. *Diabet. Med.* **2005**, *22*: 946-9.
- [69] Lin, W.H., Chuang, L.M., Chen, C.H., Yeh, J.I., Hsieh, P.S., Cheng, C.H., Chen, Y.T. Association study of genetic polymorphisms of SLC2A10 gene and type 2 diabetes in the Taiwanese population. *Diabetologia* **2006**, *49*: 1214-21.
- [70] Coucke, P.J., Willaert, A., Wessels, M.W., Callewaert, B., Zoppi, N., De Backer, J., Fox, J.E., Mancini, G.M., Kambouris, M., Gardella, R., Facchetti, F., Willems, P.J., Forsyth, R., Dietz, H.C., Barlati, S., Colombi, M., Loeys, B., De Paepe, A. Mutations in the facilitative glucose transporter GLUT10 alter angiogenesis and cause arterial tortuosity syndrome. *Nat. Genet.* **2006**, *38*: 452-7.
- [71] Doege, H., Bocianski, A., Scheepers, A., Axer, H., Eckel, J., Joost, H.G. Characterization of human glucose transporter (GLUT) 11 (encoded by SLC2A11), a novel sugar-transport facilitator specifically expressed in heart and skeletal muscle. *Biochem. J.* **2001**, *359*: 443-9.
- [72] Sasaki, T., Minoshima, S., Shiohama, A., Shintani, A., Shimizu, A., Asakawa, S., Kawasaki, K., Shimizu, N. Molecular cloning of a member of the facilitative glucose transporter gene family GLUT11 (SLC2A11) and identification of transcription variants. *Biochem. Biophys. Res. Commun.* **2001**, *289*: 1218-24.
- [73] Rogers, S., Macheda, M.L., Docherty, S.E., Carty, M.D., Henderson, M.A., Soeller, W.C., Gibbs, E.M., James, D.E., Best, J.D. Identification of a novel glucose transporter-like protein - GLUT12. *Am. J. Physiol. Endocrinol. Metab.* **2002**, *282*: E733-8.
- [74] Rogers, S., Chandler, J.D., Clarke, A.L., Petrou, S., Best, J.D. Glucose transporter GLUT12-functional characterization in *Xenopus laevis* oocytes. *Biochem. Biophys. Res. Comm.* **2003**, *308*: 422-6.
- [75] Miller, P. J., Finucane, K.A., Hughes, M., Zhao, F.-Q. Cloning and expression of bovine glucose transporter GLUT12. *Mamm. Genome* **2005**, *16*: 873-83.
- [76] Rogers, S., Docherty, S.E., Slavina, J.L., Henderson, M.A., Best, J.D. Differential expression of GLUT12 in breast cancer and normal breast tissue. *Cancer Lett.* **2003**, *193*: 225-33.
- [77] Uldry, M., Ibberson, M., Horisberger, J.D., Chatton, J.Y., Riederer, B.M., Thorens, B. Identification of a mammalian H(+)-myo-inositol symporter expressed predominantly in the brain. *EMBO J.* **2001**, *20*: 4467-77.
- [78] Uldry, M., Steiner, P., Zurich, M.G., Beguin, P., Hirling, H., Dolci, W., Thorens, B. Regulated exocytosis of an H(+)-myo-inositol symporter at synapses and growth cones. *EMBO J.* **2004**, *23*: 531-40.
- [79] Hediger, M.A., Coady, M.J., Ikeda, T.S., Wright, E.M. Expression cloning and cDNA sequencing of the Na<sup>+</sup>/glucose co-transporter. *Nature* **1987**, *330*: 379-81.
- [80] Hirayama, B.A., Loo, M.P., Panayotova-Heiermann, M., Loo, D.D., Turk, E., Wright, E.M. Kinetic and specificity differences between rat, human, and rabbit Na<sup>+</sup>-glucose cotransporters (SGLT-1). *Am. J. Physiol.* **1996**, *270*: G919-26.
- [81] Wright, E.M. The intestinal Na<sup>+</sup>/glucose cotransporter. *Ann. Rev. Physiol.* **1993**, *55*: 575-89.
- [82] Wright, E.M., Hirayama, B.A., Loo, D.D.F., Turk, E., Hager, K. Intestinal sugar transport. In: Johnson, LR (ed) Physiology of gastrointestinal tract, 3rd Edn. Raven Press, New York. **1994**, 1751-72.
- [83] Loo, D.D., Zeuthen, T., Chandy, G., Wright, E.M. Cotransport of water by the Na<sup>+</sup>/glucose cotransporter. *Proc. Natl. Acad. Sci. USA* **1996**, *93*: 13367-70.
- [84] Kanai, Y., Lee, W.S., You, G., Brown, D., Hediger, M.A. The human kidney low affinity Na<sup>+</sup>/glucose cotransporter SGLT2. Delineation of the major renal reabsorptive mechanism for D-glucose. *J. Clin. Invest.* **1994**, *93*: 397-404.
- [85] Wright, E.M. Renal Na<sup>+</sup>/glucose cotransporters. *Am. J. Physiol. Renal Physiol.* **2001**, *280*: F10-8.
- [86] Wells, R.G., Pajor, A.M., Kanai, Y., Turk, F., Wright, E.M., Hediger, M.A. Cloning of a human kidney cDNA with similarity to the sodium-glucose transporter. *Am. J. Physiol.* **1992**, *263*: F459-65.
- [87] Van den Heuvel, L.P., Assink, K., Willemsen, M., Monnens, L. Autosomal recessive renal glucosuria attributable to a mutation in the sodium glucose cotransporter (SGLT2). *Hum. Genet.* **2002**, *111*: 544-7.
- [88] Kleta, R., Stuart, C., Gill, F.A., Gahl, W.A. Renal glucosuria due to SGLT2 mutations. *Mol. Genet. Metab.* **2004**, *82*: 56-8.
- [89] Kellett, G.L., Helliwell, P.A. The diffusive component of intestinal glucose absorption is mediated by the glucose-induced recruitment of GLUT2 to the brush-border membrane. *Biochem. J.* **2000**, *350*: 155-62.
- [90] Leturque, A., Brot-Laroche, E., Le Gall, M., Stolarczyk, E., Tobin, V. The role of GLUT2 in dietary sugar handling. *J. Physiol. Biochem.* **2005**, *61*: 529-37.
- [91] Wright, E.M., Martin, M.G., Turk E. Intestinal absorption in health and disease--sugars. *Best Pract. Res. Clin. Gastroenterol.* **2003**, *17*: 943-56.
- [92] Santer, R., Hillebrand, G., Steinmann, B., Schaub, J. Intestinal glucose transport: evidence for a membrane traffic-based pathway in humans. *Gastroenterology* **2003**, *124*: 34-9.
- [93] Stumpel, F., Burcelin, R., Jungermann, K., Thorens, B. Normal kinetics of intestinal glucose absorption in the absence of GLUT2: evidence for a transport pathway requiring glucose phosphorylation and transfer into the endoplasmic reticulum. *Proc. Natl. Acad. Sci. USA.* **2001**, *98*: 11330-5.
- [94] Zhao, F.-Q., Okine, E.K., Cheeseman, C.I., Shirazi-Beechey, S.P., Kennelly, J.J. Glucose transporter gene expression in lactating bovine gastrointestinal tract. *J. Anim. Sci.* **1998**, *76*: 2921-9.
- [95] Thorens B. GLUT2 in pancreatic and extra-pancreatic gluco-detection. *Mol. Memb. Biol.* **2001**, *18*: 265-73.
- [96] Herman, M.A., Kahn, B.B. Glucose transport and sensing in the maintenance of glucose homeostasis and metabolic harmony. *J. Clin. Invest.* **2006**, *116*: 1767-75.
- [97] Levin, B.E. Metabolic sensing neurons and the control of energy homeostasis. *Physiol. Behav.* **2006**, *89*: 486-9.
- [98] Penicaud, L., Leloup, C., Fioramonti, X., Lorsignol, A., Benani, A. Brain glucose sensing: a subtle mechanism. *Curr. Opin. Clin. Nutr. Metab. Care* **2006**, *9*: 458-62.
- [99] Lam, T.K., Pocaí, A., Gutierrez-Juarez, R., Obici, S., Bryan, J., Aguilar-Bryan, L., Schwartz, G.J., Rossetti, L. Hypothalamic sensing of circulating fatty acids is required for glucose homeostasis. *Nat. Med.* **2005**, *11*: 320-7.
- [100] Thorens, B., Guillam, M.T., Beermann, F., Burcelin, R., Jaquet, M. Transgenic reexpression of GLUT1 or GLUT2 in pancreatic beta cells rescues GLUT2-null mice from early death and restores normal glucose-stimulated insulin secretion. *J. Biol. Chem.* **2000**, *275*: 23751-8.
- [101] Marty, N., Dallaporta, M., Foretz, M., Emery, M., Tarussio, D., Bady, I., Binnert, C., Beermann, F., Thorens, B. Regulation of glucagon secretion by glucose transporter type 2 (glut2) and astrocyte-dependent glucose sensors. *J. Clin. Invest.* **2005**, *115*: 3545-53.
- [102] Guillam, M.T., Dupraz, P., Thorens, B. Glucose uptake, utilization, and signaling in GLUT2-null islets. *Diabetes* **2000**, *49*: 1485-91.
- [103] Thorens, B. A gene knockout approach in mice to identify glucose sensors controlling glucose homeostasis. *Pflugers Arch.* **2003**, *445*: 482-90.
- [104] Schuit, F.C., Huypens, P., Heimberg, H., Pipeleers, D.G. Glucose sensing in pancreatic beta-cells: a model for the study of other glucose-regulated cells in gut, pancreas, and hypothalamus. *Diabetes* **2001**, *50*: 1-11.
- [105] Zhao, F.-Q., Keating, A.F. Invited review: expression and regulation of glucose transporters in the bovine mammary gland. *J. Dairy Sci.* **2007**, in press.
- [106] Furtado, L.M., Somwar, R., Sweeney, G., Niu, W., Klip, A. Activation of the glucose transporter GLUT4 by insulin. *Biochem. Cell. Biol.* **2002**, *80*: 569-78.
- [107] Bryant, N.J., Govers, R., James, D.E. Regulated transport of the glucose transporter GLUT4. *Nat. Rev. Mol. Cell. Biol.* **2002**, *3*: 267-77.
- [108] Dugani, C.B., Klip, A. Glucose transporter 4: cycling, compartments and controversies. *EMBO Rep.* **2005**, *6*: 1137-42.
- [109] Zisman, A., Peroni, O.D., Abel, E.D., Michael, M.D., Mauvais-Jarvis, F., Lowell, B.B., Wojtaszewski, J.F., Hirshman, M.F., Virkamaki, A., Goodyear, L.J., Kahn, C.R., Kahn, B.B. Targeted disruption of the glucose transporter 4 selectively in muscle causes insulin resistance and glucose intolerance. *Nat. Med.* **2000**, *6*: 924-8.
- [110] Kim, J.K., Zisman, A., Fillmore, J.J., Peroni, O.D., Kotani, K., Perret, P., Zong, H., Dong, J., Kahn, C.R., Kahn, B.B., Shulman, G.I. Glucose toxicity and the development of diabetes in mice with

- muscle-specific inactivation of GLUT4. *J. Clin. Invest.* **2001**, *108*: 153-60.
- [111] Omata, W., Shibata, H., Li, L., Takata, K., Kojima, I. Actin filaments play a critical role in insulin-induced exocytotic recruitment but not in endocytosis of GLUT4 in isolated rat adipocytes. *Biochem. J.* **2000**, *346*: 321-8.
- [112] Zeigerer, A., McBrayer, M.K., McGraw, T.E. Insulin stimulation of GLUT4 exocytosis, but not its inhibition of endocytosis, is dependent on RabGAP AS160. *Mol. Biol. Cell.* **2004**, *15*: 4406-15.
- [113] Li, L.V., Kandror, K.V. Golgi-localized, gamma-ear-containing, Arf-binding protein adaptors mediate insulin-responsive trafficking of glucose transporter 4 in 3T3-L1 adipocytes. *Mol. Endocrinol.* **2005**, *19*: 2145-53.
- [114] Proctor, K.M., Miller, S.C., Bryant, N.J., Gould, G.W. Syntaxin 16 controls the intracellular sequestration of GLUT4 in 3T3-L1 adipocytes. *Biochem. Biophys. Res. Comm.* **2006**, *347*: 433-8.
- [115] Ramm, G., Larance, M., Guilhaus, M., James, D.E. A role for 14-3-3 in insulin-stimulated GLUT4 translocation through its interaction with the RabGAP AS160. *J. Biol. Chem.* **2006**, *281*: 29174-80.
- [116] Van Dam, E.M., Govers, R., James, D.E. Akt activation is required at a late stage of insulin-induced GLUT4 translocation to the plasma membrane. *Mol. Endocrinol.* **2005**, *19*: 1067-77.
- [117] Chiang, S.H., Baumann, C.A., Kanzaki, M., Thurmond, D.C., Watson, R.T., Neudauer C.L., Macara, I.G., Pessin, J.E., Saltiel, A.R. Insulin-stimulated GLUT4 translocation requires the CAP-dependent activation of TC10. *Nature* **2001**, *410*: 944-8.
- [118] Watson, R.T., Shigematsu, S., Chiang, S.H., Mora, S., Kanzaki, M., Macara, I.G., Saltiel, A.R., Pessin, J.E. Lipid raft microdomain compartmentalization of TC10 is required for insulin signaling and GLUT4 translocation. *J. Cell. Biol.* **2001**, *154*: 829-40.
- [119] Kanzaki, M., Pessin, J.E. Insulin-stimulated GLUT4 translocation in adipocytes is dependent upon cortical actin remodeling. *J. Biol. Chem.* **2001**, *276*: 42436-44.
- [120] Hajdich, E., Hainault, I., Meunier, C., Jardel, C., Hainque, B., Guerre-Millo, M., Lavau, M. Regulation of glucose transporters in cultured rat adipocytes: synergistic effect of insulin and dexamethasone on GLUT4 gene expression through promoter activation. *Endocrinology* **1995**, *136*: 4782-9.
- [121] Hernandez, R., Teruel, T., Lorenzo, M. Insulin and dexamethasone induce GLUT4 gene expression in foetal brown adipocytes: synergistic effect through CCAAT/enhancer-binding protein alpha. *Biochem. J.* **2003**, *372*: 617-24.
- [122] Haney, P.M. Localization of the GLUT1 glucose transporter to brefeldin A-sensitive vesicles of differentiated C173 mouse mammary epithelial cells. *Cell Biol. Int.* **2001**, *25*: 277-88.
- [123] Zhao, F.-Q., Moseley, M.W., Tucker, H.A., Kennelly, J.J. Regulation of glucose transporter gene expression in mammary gland, muscle and fat of lactating cows by administration of bovine growth hormone and bovine growth hormone-releasing factor. *J. Anim. Sci.* **1996**, *74*: 183-9.
- [124] Doege, H., Schurmann, A., Bahrenberg, G., Brauers, A., Joost, H.G. GLUT8, a novel member of the sugar transport facilitator family with glucose transport activity. *J. Biol. Chem.* **2000**, *275*: 16275-80.
- [125] Santalucia, T., Palacin, M., Zorzano, A. T3 strongly regulates GLUT1 and GLUT3 mRNA in cerebral cortex of hypothyroid rat neonates. *Mol. Cell. Endocrinol.* **2006**, *251*: 9-16.
- [126] Weinstein, S.P., O'Boyle, E., Fisher, M., Haber, R.S. Regulation of GLUT2 glucose transporter expression in liver by thyroid hormone: evidence for hormonal regulation of the hepatic glucose transport system. *Endocrinology* **1994**, *135*: 649-54.
- [127] Shimizu, Y., Shimazu, T. Thyroid hormone augments GLUT4 expression and insulin-sensitive glucose transport system in differentiating rat brown adipocytes in culture. *J. Vet. Med. Sci.* **2002**, *64*: 677-81.
- [128] Weinstein, S.P., Watts, J., Haber, R.S. Thyroid hormone increases muscle/fat glucose transporter gene expression in rat skeletal muscle. *Endocrinology* **1991**, *129*: 455-64.
- [129] Hwang, D.Y., Ismail-Beigi, F. Stimulation of GLUT-1 glucose transporter expression in response to hyperosmolarity. *Am. J. Physiol. Cell. Physiol.* **2001**, *281*: C1365-72.
- [130] Hwang, D.Y., Ismail-Beigi, F. Control of GLUT1 promoter activity under basal conditions and in response to hyperosmolarity: role of Sp1. *Am. J. Physiol. Cell. Physiol.* **2006**, *290*: C337-44.
- [131] Sanchez-Feutrie, M., Santalucia, T., Fandos, C., Noe, V., Vinals, F., Brand, N.J., Ciudad, C.J., Palacin, M., Zorzano, A. A novel muscle DNA-binding activity in the GLUT1 promoter. *Cell. Mol. Life Sci.* **2004**, *61*: 709-20.
- [132] Sanchez-Feutrie, M., Vinals, F., Palacin, M., Zorzano, A. Identification of a novel proliferation-dependent C-rich element that mediates inhibition of the rat GLUT1 promoter. *Gene* **2003**, *322*: 47-55.
- [133] Schwartzberg-Bar-Yoseph, F., Armoni, M., Karnieli, E. The tumor suppressor p53 down-regulates glucose transporters GLUT1 and GLUT4 gene expression. *Cancer Res.* **2004**, *64*: 2627-33.
- [134] Murakami, T., Nishiyama, T., Shirotani, T., Shinohara, Y., Kan, M., Ishii, K., Kanai, F., Nakazuru, S., Ebina, Y. Identification of two enhancer elements in the gene encoding the type 1 glucose transporter from the mouse which are responsive to serum, growth factor, and oncogenes. *J. Biol. Chem.* **1992**, *267*: 9300-6.
- [135] Todaka, M., Nishiyama, T., Murakami, T., Saito, S., Ito, K., Kanai, F., Kan, M., Ishii, K., Hayashi, H., Shichiri, M., Ebina, Y. The role of insulin in activation of two enhancers in the mouse GLUT1 gene. *J. Biol. Chem.* **1994**, *269*: 29265-70.
- [136] Boado, R.J., Pardridge, W.M. Ten nucleotide cis element in the 3'-untranslated region of the GLUT1 glucose transporter mRNA increases gene expression via mRNA stabilization. *Brain Res. Mol. Brain Res.* **1998**, *59*: 109-13.
- [137] Bonny, C., Thompson, N., Nicod, P., Waeber, G. Pancreatic-specific expression of the glucose transporter type 2 gene: identification of cis-elements and islet-specific trans-acting factors. *Mol. Endocrinol.* **1995**, *9*: 1413-26.
- [138] Waeber, G., Pedrazzini, T., Bonny, O., Bonny, C., Steinmann, M., Nicod, P., Haefliger, J.A. A 338-bp proximal fragment of the glucose transporter type 2 (GLUT2) promoter drives reporter gene expression in the pancreatic islets of transgenic mice. *Mol. Cell. Endocrinol.* **1995**, *114*: 205-15.
- [139] Cha, J.Y., Kim, H., Kim, K.S., Hur, M.W., Ahn, Y. Identification of transacting factors responsible for the tissue-specific expression of human glucose transporter type 2 isoform gene. Cooperative role of hepatocyte nuclear factors 1alpha and 3beta. *J. Biol. Chem.* **2000**, *275*: 18358-65.
- [140] Im, S.S., Kang, S.Y., Kim, S.Y., Kim, H.I., Kim, J.W., Kim, K.S., Ahn, Y.H. Glucose-stimulated upregulation of GLUT2 gene is mediated by sterol response element-binding protein-1c in the hepatocytes. *Diabetes* **2005**, *54*: 1684-91.
- [141] Waeber, G., Thompson, N., Nicod, P., Bonny, C. Transcriptional activation of the GLUT2 gene by the IPF-1/STF-1/IDX-1 homeobox factor. *Mol. Endocrinol.* **1996**, *10*: 1327-34.
- [142] Kim, J.W., Ahn, Y.H. CCAAT/enhancer binding protein regulates the promoter activity of the rat GLUT2 glucose transporter gene in liver cells. *Biochem. J.* **1998**, *336*: 83-90.
- [143] Kim, H.I., Kim, J.W., Kim, S.H., Cha, J.Y., Kim, K.S., Ahn, Y.H. Identification and functional characterization of the peroxisomal proliferators response element in rat GLUT2 promoter. *Diabetes* **2000**, *49*: 1517-24.
- [144] Olson, A.L., Pessin, J.E. Transcriptional regulation of the human GLUT4 gene promoter in diabetic transgenic mice. *J. Biol. Chem.* **1995**, *270*: 23491-5.
- [145] Thai, M.V., Guruswamy, S., Cao, K.T., Pessin, J.E., Olson, A.L. Myocyte enhancer factor 2 (MEF2)-binding site is required for GLUT4 gene expression in transgenic mice. Regulation of MEF2 DNA binding activity in insulin-deficient diabetes. *J. Biol. Chem.* **1998**, *273*: 14285-92.
- [146] Oshel, K.M., Knight, J.B., Cao, K.T., Thai, M.V., Olson, A.L. Identification of a 30-base pair regulatory element and novel DNA binding protein that regulates the human GLUT4 promoter in transgenic mice. *J. Biol. Chem.* **2000**, *275*: 23666-73.
- [147] Knight, J.B., Eyster, C.A., Griesel, B.A., Olson, A.L. Regulation of the human GLUT4 gene promoter: interaction between a transcriptional activator and myocyte enhancer factor 2A. *Proc. Natl. Acad. Sci. USA.* **2003**, *100*: 14725-30.
- [148] Holmes, B.F., Sparling, D.P., Olson, A.L., Winder, W.W., Dohm, G.L. Regulation of muscle GLUT4 enhancer factor and myocyte enhancer factor 2 by AMP-activated protein kinase. *Am. J. Physiol. Endocrinol. Metab.* **2005**, *289*: E1071-6.
- [149] Santalucia, T., Moreno, H., Palacin, M., Yacoub, M.H., Brand, N.J., Zorzano, A. A novel functional co-operation between MyoD, MEF2 and TRalpha1 is sufficient for the induction of GLUT4 gene transcription. *J. Mol. Biol.* **2001**, *314*: 195-204.
- [150] Im, S.S., Kwon, S.K., Kang, S.Y., Kim, T.H., Kim, H.I., Hur, M.W., Kim, K.S., Ahn, Y.H. Regulation of GLUT4 gene expression by SREBP-1c in adipocytes. *Biochem. J.* **2006**, *399*: 131-9.

- [151] Zorzano, A., Palacin, M., Guma, A. Mechanisms regulating GLUT4 glucose transporter expression and glucose transport in skeletal muscle. *Acta. Physiol. Scand.* **2005**, *183*: 43-58.
- [152] Scheepers, A., Doege, H., Joost, H.G., Schurmann, A. Mouse GLUT8: genomic organization and regulation of expression in 3T3-L1 adipocytes by glucose. *Biochem. Biophys. Res. Comm.* **2001**, *288*: 969-74.
- [153] Lamb, D.J. Genes involved in testicular development and function. *World J. Urol.* **1995**, *13*: 277-84.
- [154] Koopman, P. Sry and Sox9: Mammalian testis determining genes. *Cell. Mol. Life Sci.* **1999**, *55*: 839-56.
- [155] Segade, F., Allred, D.C., Bowden, D.W. Functional characterization of the promoter of the human glucose transporter 10 gene. *Biochim. Biophys. Acta* **2005**, *1730*: 147-58.
- [156] Gosmanov, A.R., Umpierrez, G.E., Karabell, A.H., Cuervo, R., Thomason, D.B. Impaired expression and insulin-stimulated phosphorylation of Akt-2 in muscle of obese patients with atypical diabetes. *Am. J. Physiol. Endocrinol. Metab.* **2004**, *287*: E8-15.
- [157] Karlsson, H.K., Zierath, J.R., Kane, S., Krook, A., Lienhard, G.E., Wallberg-Henriksson, H. Insulin-stimulated phosphorylation of the Akt substrate AS160 is impaired in skeletal muscle of type 2 diabetic subjects. *Diabetes* **2005**, *54*: 1692-7.
- [158] Karlsson, H.K., Ahlsen, M., Zierath, J.R., Wallberg-Henriksson, H., Koistinen, H.A. Insulin signaling and glucose transport in skeletal muscle from first-degree relatives of type 2 diabetic patients. *Diabetes* **2006**, *55*: 1283-8.
- [159] Petersen, K.F., Shulman, G.I. Etiology of insulin resistance. *Am. J. Med.* **2006**, *119*: S10-6.
- [160] Shepherd, P.R., Kahn, B.B. Glucose transporters and insulin action—implications for insulin resistance and diabetes mellitus. *N. Engl. J. Med.* **1999**, *341*: 248-57.
- [161] Carvalho, E., Kotani, K., Peroni, O.D., Kahn, B.B. Adipose-specific overexpression of GLUT4 reverses insulin resistance and diabetes in mice lacking GLUT4 selectively in muscle. *Am. J. Physiol. Endocrinol. Metab.* **2005**, *289*: E551-61.
- [162] Reske, S.N., Grillenberger, K.G., Glatting, G., Port, M., Hildebrandt, M., Gansauge, F., Beger, H.G. Overexpression of glucose transporter 1 and increased FDG uptake in pancreatic carcinoma. *J. Nucl. Med.* **1997**, *38*: 1344-8.
- [163] Higashi, T., Tamaki, N., Torizuka, T., Nakamoto, Y., Sakahara, H., Kimura, T., Honda, T., Inokuma, T., Katsushima, S., Ohshio, G., Imamura, M., Konishi, J. FDG uptake, GLUT-1 glucose transporter and cellularity in human pancreatic tumors. *J. Nucl. Med.* **1998**, *39*: 1727-35.
- [164] Yen, T.C., See, L.C., Lai, C.H., Yah-Huei, C.W., Ng, K.K., Ma, S.Y., Lin, W.J., Chen, J.T., Chen, W.J., Lai, C.R., Hsueh, S. 18F-FDG uptake in squamous cell carcinoma of the cervix is correlated with glucose transporter 1 expression. *J. Nucl. Med.* **2004**, *45*: 22-9.
- [165] Kato, H., Takita, J., Miyazaki, T., Nakajima, M., Fukai, Y., Masuda, N., Fukuchi, M., Manda, R., Ojima, H., Tsukada, K., Kuwano, H., Oriuchi, N., Endo, K. Correlation of 18-F-fluorodeoxyglucose (FDG) accumulation with glucose transporter (Glut-1) expression in esophageal squamous cell carcinoma. *Anticancer Res.* **2003**, *23*: 3263-72.
- [166] Chung, J.K., Lee, Y.J., Kim, S.K., Jeong, J.M., Lee, D.S., Lee, M.C. Comparison of [18F]fluorodeoxyglucose uptake with glucose transporter-1 expression and proliferation rate in human glioma and non-small-cell lung cancer. *Nucl. Med. Comm.* **2004**, *25*: 11-7.
- [167] Roh, M.S., Jeong, J.S., Kim, Y.H., Kim, M.C., Hong, S.H. Diagnostic utility of GLUT1 in the differential diagnosis of liver carcinomas. *Hepatogastroenterology* **2004**, *51*: 1315-8.
- [168] Yasuda, M., Ogane, N., Hayashi, H., Kameda, Y., Miyagi, Y., Iida, T., Mori, Y., Tsukinoki, K., Minematsu, T., Osamura, Y. Glucose transporter-1 expression in the thyroid gland: clinicopathological significance for papillary carcinoma. *Oncol. Rep.* **2005**, *14*: 1499-504.
- [169] Cantuaria, G., Magalhaes, A., Penalver, M., Angioli, R., Braunschweiger, P., Gomez-Marin, O., Kanhoush, R., Gomez-Fernandez, C., Nadji, M. Expression of GLUT-1 glucose transporter in borderline and malignant epithelial tumors of the ovary. *Gynecol. Oncology* **2000**, *79*: 33-7.
- [170] Rudlowski, C., Moser, M., Becker, A.J., Rath, W., Buttner, R., Schroder, W., Schurmann, A. GLUT1 mRNA and protein expression in ovarian borderline tumors and cancer. *Oncology* **2004**, *66*: 404-10.
- [171] Ozcan, A., Deveci, M.S., Oztas, E., Dede, M., Yenen, M.C., Korgun, E.T., Gunhan, O. Prognostic value of GLUT-1 expression in ovarian surface epithelial tumors: a morphometric study. *Anal. Quant. Cytol. Histol.* **2005**, *27*: 181-6.
- [172] North, P.E., Waner, M., Mizeracki, A., Mihm, M.C. Jr. GLUT1: a newly discovered immunohistochemical marker for juvenile hemangiomas. *Hum. Pathol.* **2000**, *31*: 11-22.
- [173] Noguchi, Y., Marat, D., Saito, A., Yoshikawa, T., Doi, C., Fukuzawa, K., Tsuburaya, A., Satoh, S., Ito, T. Expression of facilitative glucose transporters in gastric tumors. *Hepatogastroenterology* **1999**, *46*: 2683-9.
- [174] Effert, P., Beniers, A.J., Tamimi, Y., Handt, S., Jakse, G. Expression of glucose transporter 1 (Glut-1) in cell lines and clinical specimens from human prostate adenocarcinoma. *Anticancer Res.* **2004**, *24*: 3057-63.
- [175] Brown, R.S., Wahl, R.L. Overexpression of Glut-1 glucose transporter in human breast cancer. An immunohistochemical study. *Cancer* **1993**, *72*: 2979-85.
- [176] Brown, R.S., Goodman, T.M., Zasadny, K.R., Greenson, J.K., Wahl, R.L. Expression of hexokinase II and Glut-1 in untreated human breast cancer. *Nucl. Med. Biol.* **2002**, *29*: 443-53.
- [177] Zamora-Leon, S.P., Golde, D.W., Concha, II., Rivas, C.I., Delgado-Lopez, F., Baselga, J., Nualart, F., Vera, J.C. Expression of the fructose transporter GLUT5 in human breast cancer. *Proc. Natl. Acad. Sci. USA.* **1996**, *93*: 1847-52. Erratum in: *Proc. Natl. Acad. Sci. USA.* **1996**, *93*: 15522.
- [178] Chan, K.K., Chan, J.Y.W., Chung, K.K.W., Kwok-Pui, F. Inhibition of cell proliferation in human breast tumor cells by antisense oligonucleotides against facultative glucose transporter 5. *J. Cell. Biol.* **2004**, *93*: 1134-42.
- [179] Godoy, A., Ulloa, V., Rodriguez, F., Reinicke, K., Yanez, A.J., Garcia Mde, L., Medina, R.A., Carrasco, M., Barberis, S., Castro, T., Martinez, F., Koch, X., Vera, J.C., Poblete, M.T., Figueroa, C.D., Peruzzo, B., Perez, F., Nualart, F. Differential subcellular distribution of glucose transporters GLUT1-6 and GLUT9 in human cancer: ultrastructural localization of GLUT1 and GLUT5 in breast tumor tissues. *J. Cell. Physiol.* **2006**, *207*: 614-27.