

Constitutive and Retinoic Acid-Inducible Expression of Cytomegalovirus Immediate-Early Genes in Human Teratocarcinoma Cells

ROBERT LAFEMINA* AND GARY S. HAYWARD

The Virology Laboratories, Department of Pharmacology, Johns Hopkins University School of Medicine, Baltimore, Maryland 21205

Received 9 September 1985/Accepted 28 January 1986

Human teratocarcinoma stem cells are nonpermissive for human cytomegalovirus (HCMV) but become permissive after being induced to differentiate by treatment with retinoic acid. We show that in uninduced teratocarcinoma stem cells, and also in transformed human 293 cells expressing adenovirus E1a gene products, the HCMV immediate-early (IE) 68,000-molecular-weight polypeptide (68K polypeptide) was not expressed, and consequently input viral genomes were not replicated. However, after differentiation of the teratocarcinoma cells, synthesis of the HCMV IE 68K polypeptide was induced, and viral DNA replication occurred. In contrast to our observations for HCMV, simian cytomegalovirus (SCMV) displayed constitutive expression of its analogous IE 94K polypeptide, and the input SCMV genomes were replicated in both uninduced stem cells and 293 cells. Since little, if any, HCMV IE RNA was detectable in human teratocarcinoma or 293 cells after infection under IE conditions, we suggest that a direct transcriptional block to permissivity occurs in these cells. The presence of tandemly repeated sequences which bind nuclear factor I protein in the promoter for the SCMV IE 94K polypeptide gene but not in the promoter for the HCMV IE 68K polypeptide gene may allow the expression of the simian but not of the human IE gene product in transformed cells.

Human cytomegalovirus (HCMV) displays a strict host-cell type and species specificity (27, 29, 38). Efficient replication and release of progeny virus occurs only in diploid human foreskin fibroblast (HF) cells, although other human cell types, including epithelial cells (19, 37) and osteosarcoma cells (R. L. LaFemina and G. S. Hayward, manuscript in preparation), are moderately permissive. Cytomegalovirus (CMV) infection in the presence of cycloheximide results in the synthesis of immediate-early (IE) mRNA only. After removal of the cycloheximide block in the presence of actinomycin D, the predominant HCMV (Towne) IE 68,000-molecular-weight (68K protein) (11, 21, 32) or the counterpart simian CMV (SCMV [Colburn]) IE 94K protein (16, 17) is synthesized. Both gene products are nuclear phosphoproteins, and by analogy with other herpesvirus systems, these CMV IE polypeptides may play a role in regulating the expression of subsequent delayed-early gene products, some of which are involved in viral genome replication.

In addition to viral factors, there are host-cell factors necessary for HCMV gene expression and replication, such that HCMV gene expression and DNA replication may be blocked at several levels in nonpermissive cells. Although the HCMV IE 68K polypeptide is synthesized after infection of rodent fibroblasts, the polypeptide apparently does not function properly, such that delayed-early gene products are not detectable and input HCMV genomes are not replicated (21, 32). The HCMV IE polypeptide has a postulated transcriptional regulatory function, and in rabbit fibroblasts there appears to be a deficiency in the association of specific delayed-early transcripts with polysomes (7). A separate block is observed at an earlier level in transformed cell lines such that input HCMV genomes are found in the infected

cell nucleus, but the IE 68K polypeptide is not synthesized, and consequently the input HCMV genomes are not replicated (LaFemina and Hayward, manuscript in preparation). Thus, an understanding of the required host-cell functions may provide insights into the use of cell culture lines as model systems for CMV latency.

In an effort to counteract the problems associated with the host-cell type and species specificity, previous investigators have turned to animal models to study HCMV latency. Models for murine CMV latency have been described, which appear to require in vitro cellular differentiation for the induction of reactivated murine CMV gene expression and replication (8). Similar experiments are difficult to perform for HCMV, but the importance of cell differentiation led Gonczol et al. (12, 13) to examine the use of human teratocarcinoma cells in culture as a possible model for HCMV latency. They showed that HCMV-infected human teratocarcinoma stem cells do not express viral antigens and that progeny virus is not produced. However, differentiation of these cells by retinoic acid treatment permits expression of viral antigens and release of progeny virus (12, 13). These earlier results were obtained by using immunofluorescence assays with human immune serum for gene expression and by using determinations of progeny virus titers as assays for virus replication. In the present studies, we have used the more biochemical methods of sodium dodecyl sulfate (SDS)-polyacrylamide gel electrophoresis to detect the expression of specific ³⁵S-labeled IE gene products and the restriction enzyme cleavage analysis of ³²P-radiolabeled, newly synthesized DNA for the detection of viral DNA replication (21) in an attempt to localize the block in these cells.

Previous studies from our laboratory demonstrated that both HCMV and SCMV behaved similarly when rodent cell lines were used as nonpermissive hosts. In both cases, IE gene products were synthesized, delayed-early polypeptide

* Corresponding author.

synthesis was minimal, and viral DNA replication was not detectable (16, 21). In the course of the present studies, a distinct contrast was noticed between the expression and replication of HCMV (Towne) and SCMV (Colburn) in transformed human cells. We suggest that this may be related to differences in the upstream regulatory sequences in the IE promoter of these two viruses.

MATERIALS AND METHODS

Cell culture. All cells used in these studies were cultured in Dulbecco modified Eagle medium (GIBCO Laboratories) supplemented with 10% fetal calf serum (Hyclone). 293 cells, which express adenovirus E1a genes (14), were a gift from Gary Ketner of Johns Hopkins University. These cells are only loosely adherent to the plastic tissue culture flask and thus could be subcultured by shaking the flask to remove the cells and dilution (1:10) with fresh media. Seed cultures of the human embryonal carcinoma cell line NTera 2/D1 were a gift from Peter Andrews of the Wistar Institute and were cultured as described previously (1, 2). To maintain the cells in the undifferentiated state, the monolayer was disrupted by shaking with glass beads followed by subculture at low dilution (1:3) in Dulbecco modified Eagle medium–10% fetal calf serum supplemented with glucose (4 mg/ml). Differentiation of these cells was achieved by trypsinization followed by subculture in this same media containing 10^{-6} M retinoic acid (R-2625; Sigma Chemical Co.) for a minimum of 4 days. Secondary cultures of diploid HF cells were maintained as previously described (21).

Detection of newly replicated viral DNA. HCMV (Towne) stock cultures were grown and passaged at a low multiplicity of infection to prevent the production of virus particles containing defective genomes (21, 33). For ^{32}P labeling of newly replicated viral DNA, cell monolayers at 95% confluence were infected at high multiplicities (i.e., 20) for 18 h. At this time, cells were cultured in phosphate-free Dulbecco modified Eagle medium (GIBCO) containing 10% dialyzed fetal calf serum and 100 μCi of $^{32}\text{P}_i$ per ml. At 5 to 7 days after infection, cells were harvested and lysed by treatment with SDS and Sarkosyl as described previously (21). After pronase treatment (1 mg/ml, 12 h, 37°C), infected cell DNA was isolated by standard phenol, chloroform, and ethanol precipitation procedures. The dried DNA pellet was suspended in 10 mM Tris hydrochloride (pH 8.4)–1 mM EDTA and used for restriction endonuclease cleavage analysis. Generally, *SalI* or *XhoI* was used for the analysis of HCMV-infected cell DNA because these enzymes do not cleave the bulk of cell DNA which contains methylated cytosine-guanine (CpG) doublet. Thus, viral DNA fragments could be separated from high-molecular-weight DNA by electrophoresis through 1% agarose gels as described previously (21). Although these gels could be directly dried for autoradiography, lower background signals were obtained when the DNA was transferred to nitrocellulose. Autoradiography of the transferred DNA was achieved by the exposure of Kodak XAR-5 film for 1 to 7 days at 20°C. These conditions were required to detect even minute amounts of HCMV DNA replication; however, SCMV DNA synthesis was abundant in all cell types used in these studies and could be detected over background cell DNA replication even by the use of *HindIII* and *BamHI*.

IE polypeptide detection. Cell monolayers were infected at a high multiplicity in the presence of 50 μg of cycloheximide (Sigma) per ml for 16 h. Cells were carefully washed three times with calcium- and magnesium-free phosphate-buffered

saline and incubated in methionine-free Dulbecco modified Eagle medium (GIBCO) supplemented with 10% dialyzed fetal calf serum and 25 μCi of [^{35}S]methionine per ml for 3 h. Cells were washed again and lysed by the addition of Nonidet P-40 and SDS, and cell extracts containing polypeptides labeled under these IE conditions were processed as described previously (11, 21). SDS-polyacrylamide gel electrophoresis was carried out in 10% polyacrylamide slab gels (11, 21). Radiolabeled polypeptides were visualized by fluorography with Kodak XAR-5 film exposed at -70°C .

RNA dot blot analysis. For the detection of HCMV IE 68K RNA, cell cultures were infected at a high multiplicity in the presence of cycloheximide. RNA was isolated from equivalent cell numbers by the guanidinium-cesium chloride method described by Chirgwin et al. (5). The RNA, which was pelleted through a 1-ml cushion of 5.7 M CsCl in 0.1 M EDTA after centrifugation in a Beckman SW50.1 rotor at 35,000 rpm for 16 h, was dissolved in 10 mM Tris hydrochloride (pH 7.4)–5 mM EDTA–1% SDS and stored in ethanol at -20°C before use. Total infected cell RNA was dissolved in 200 μl of 50% formamide–5% formaldehyde–20 mM MOPS (morpholinepropanesulfonic acid; pH 7.0) and bound to nitrocellulose by filtration through a 96-well dot blot apparatus (Schleicher & Schuell, Inc.). Nitrocellulose filters were washed in $2\times$ SSC ($1\times$ SSC is 0.15 M NaCl plus 0.015 M sodium citrate) and baked at 80°C for 4 h under vacuum. Prehybridization, hybridization, and filter washing were carried out by using the procedures described by Thomas (35). The hybridization probe used was the plasmid pRL42, which contains a *BamHI-HindIII* portion of the HCMV (Towne) *BamHI* J fragment and includes the coding region for the IE 68K polypeptide. After hybridization, the nitrocellulose filters were stained with methylene blue by the procedure of Zinn et al. (39) to confirm that equivalent amounts of RNA were used in these assays.

RESULTS

Undifferentiated human teratocarcinoma stem cells do not replicate input HCMV genomes. To determine whether the block to HCMV progeny virion production in undifferentiated human teratocarcinoma cells occurs before or after DNA replication, permissive HF cells and uninduced or retinoic acid-induced human teratocarcinoma cells (NTera 2/D1) were infected with HCMV (Towne). Newly synthesized DNA in infected and mock-infected cells was labeled with $^{32}\text{P}_i$ for 5 days and then extracted and cleaved with *SalI* for analysis (Fig. 1a). Since we have never observed CpG methylation of HCMV genomes in infected cells, the use of this enzyme (which does not cleave methylated sequences) served to readily separate newly replicated viral DNA from high-molecular-weight radiolabeled cell DNA containing methylated CpG dimers. The results showed that newly synthesized viral DNA restriction fragments were recovered from infected permissive HF cells and from infected retinoic acid-induced human teratocarcinoma cells but that ^{32}P -labeled viral fragments were not detected after infection of uninduced teratocarcinoma stem cells. Therefore, HCMV-infected HF cells and retinoic acid-treated human teratocarcinoma cells replicated the input HCMV DNA, but the untreated human teratocarcinoma stem cells did not. Infection of teratocarcinoma cells for 48 h before induction, followed by washing, trypsinization, and retinoic acid treatment, also resulted in activation of viral DNA synthesis, demonstrating that the block to CMV replication was unlikely to have been caused by a lack of virion penetration (data not shown).

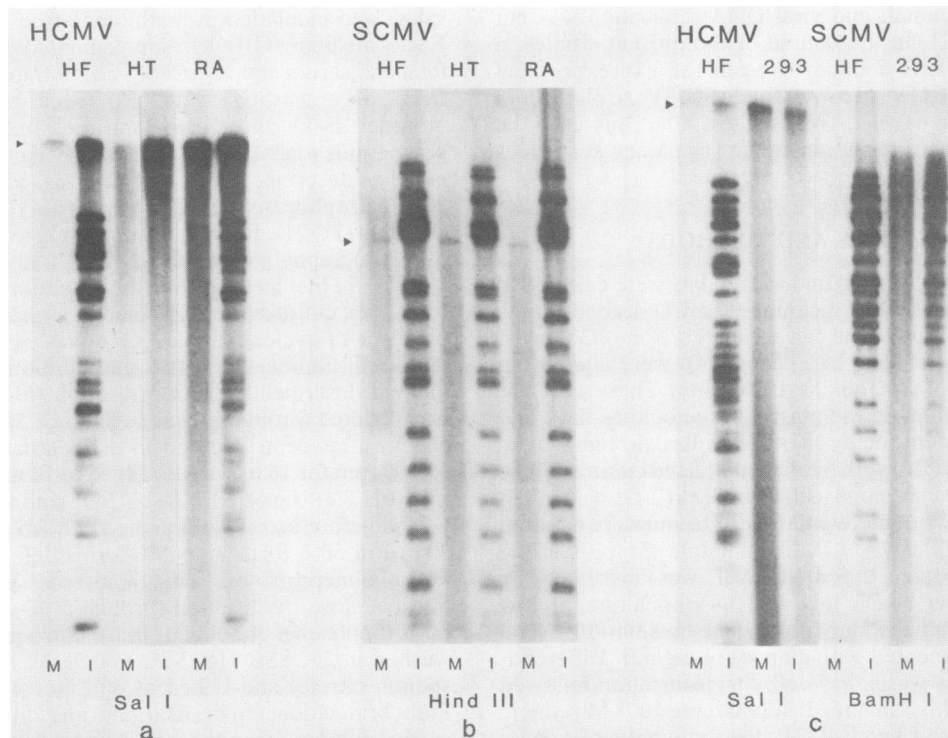

FIG. 1. Comparison of HCMV and SCMV DNA replication in transformed human cell lines. (a) HCMV DNA synthesis does not occur in human teratocarcinoma cells but can be induced after differentiation with retinoic acid. (b) Constitutive synthesis of SCMV (Colburn) DNA occurs in human teratocarcinoma stem cells. (c) SCMV but not HCMV DNA synthesis occurs in transformed human 293 cells which express adenovirus E1a genes. Cellular DNA from mock-infected (lanes M) or virus-infected (lanes I) HF cells (HF lanes), human NTera 2/D1 teratocarcinoma cells (HT lanes) and retinoic acid-induced human teratocarcinoma cells (RA lanes), and 293 cells (293 lanes) was digested with *Sal*I, *Hind*III, or *Bam*HI and subjected to agarose gel electrophoresis for the detection of replicating viral genomes. DNA extracted from HCMV-infected HF and retinoic acid-induced human teratocarcinoma cells but not NTera 2/D1 or 293 cells showed the presence of newly replicated 32 P-labeled HCMV DNA which was detected by direct autoradiography after transfer to nitrocellulose sheets. Newly synthesized SCMV DNA was similarly detected in all cell types. Arrowheads indicate the location of high-molecular-weight cellular and mitochondrial DNA (21). The procedures used for cell culture, retinoic acid induction, HCMV infection, and 32 P labeling of newly synthesized DNA were described in Materials and Methods.

HCMV-infected teratocarcinoma stem cells do not synthesize the IE 68K protein. Some nonpermissive lines, such as murine BALB/c-3T3 cells, express the HCMV IE 68K polypeptide but do not proceed to replicate input viral genomes (21). Since HCMV DNA replication was not detectable in the teratocarcinoma stem cells, we also wished to know whether the IE 68K protein was synthesized in these cells. Permissive HF and teratocarcinoma cells, together with retinoic acid-induced teratocarcinoma cells were each infected with HCMV (Towne) in the presence of cycloheximide for 16 h, followed by cycloheximide reversal in the presence of [35 S]methionine for 3 h (i.e., under IE conditions). Analysis of extracted polypeptides revealed that infection of human teratocarcinoma stem cells did not give any detectable synthesis of the IE 68K polypeptide; however, [35 S]labeled HCMV IE 68K polypeptide was produced in those cells after retinoic acid treatment (Fig. 2a, lanes 4 and 6). These results demonstrate that cell differentiation has a direct effect on HCMV IE 68K polypeptide expression.

Human cells which express adenovirus E1a do not synthesize the HCMV IE 68K polypeptide or replicate the viral DNA. Since the transformed human teratocarcinoma cell line did not synthesize the IE 68K polypeptide, we wanted to examine HCMV IE 68K polypeptide synthesis in other transformed human cell lines. The 293 cell line was chosen because these cells constitutively express adenovirus E1a genes which have a known transcriptional activation effect

on adenovirus early genes and on some cellular genes (15). Interestingly, mouse F9 teratocarcinoma cells appear to express a cellular product which allows human adenovirus E2 gene expression to bypass the requirement for E1a, but this function is lost after differentiation (15). The effect of the E1a gene products on HCMV gene expression and DNA replication in a transformed human cell environment was investigated directly by the infection of 293 cells with HCMV. Infection in the presence of cycloheximide followed by reversal in the presence of [35 S]methionine revealed that, like the teratocarcinoma cells, 293 cells failed to synthesize HCMV IE 68K (Fig. 2b, lane 4). Infection of 293 cells with 32 P-labeled virus resulted in the detection of radiolabeled input viral DNA in the cell nucleus (data not shown), suggesting that for 293 cells the block to permissivity probably does not lie at the level of virion penetration. Unlike the teratocarcinoma cells, prior treatment of 293 cells with retinoic acid did not result in HCMV IE 68K synthesis after infection (data not shown).

Both NTera 2/D1 and 293 cells synthesize the SCMV IE 94K polypeptide and replicate input SCMV genomes. HCMV and SCMV share DNA sequence homology in their respective IE promoter regulatory regions and HF cells are fully permissive hosts for SCMV replication. Thus, we wanted to know whether SCMV IE94K expression and DNA replication occurred in transformed human cells and if cell differentiation was required for expression of the SCMV gene encoding

the IE 94K protein (IE94) in human teratocarcinoma stem cells. Although HCMV DNA replication and IE68 gene expression were inducible by retinoic acid treatment of teratocarcinoma cells, SCMV IE94 expression proved to be constitutive in the uninduced cells (Fig. 3a, lane 4). The

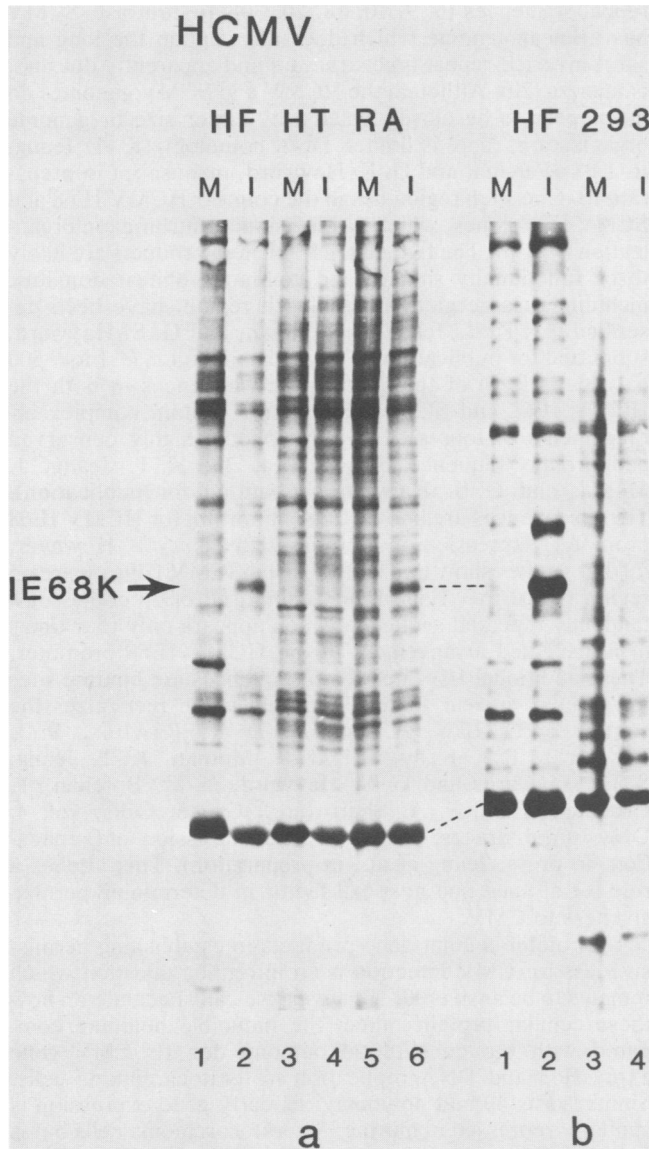

FIG. 2. HCMV IE 68K polypeptide is not synthesized in transformed human cells. (a) Retinoic acid treatment induces the expression of HCMV IE68 in human teratocarcinoma cells. Shown are polypeptides from mock-infected (lane 1) and HCMV-infected (lane 2) HF cells, mock-infected (lane 3) and HCMV-infected (lane 4) human teratocarcinoma cells, and mock-infected (lane 5) and HCMV-infected retinoic acid-induced human teratocarcinoma cells. (b) HCMV IE68K polypeptide is not synthesized in transformed human 293 cells which express adenovirus E1a gene products. Shown are mock-infected (lane 1) and HCMV-infected (lane 2) HF cells and mock-infected (lane 3) and HCMV-infected (lane 4) 293 cells. Polypeptides labeled under IE conditions were analyzed by SDS-polyacrylamide gel electrophoresis. The location of the HCMV IE 68K polypeptide detected in lanes 2 and 6 of panel a and lane 2 of panel b is arrowed. The conditions used for the infection of cultured cells in the presence of cycloheximide followed by reversal in the presence of [³⁵S]methionine are described in Materials and Methods.

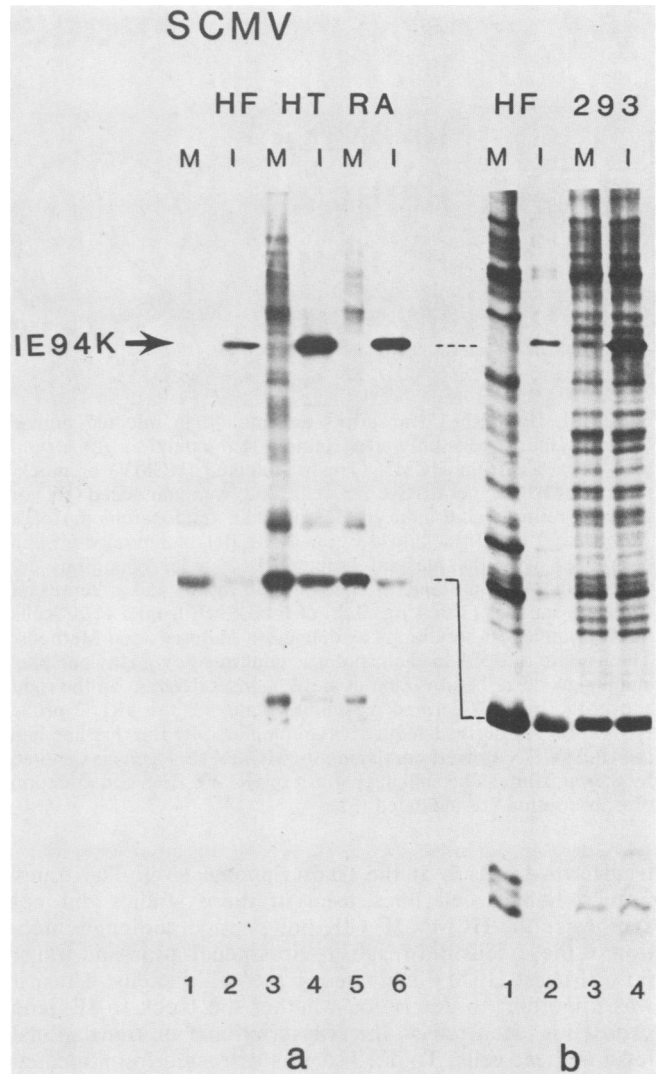

FIG. 3. The SCMV (Colburn) IE 94K polypeptide is constitutively expressed after infection of transformed cells. Human teratocarcinoma stem cells (a) and transformed human 293 cells (b) express SCMV IE94. Arrow denotes the location of the SCMV IE 94K polypeptide detectable in lanes 2, 4, and 6 of panel a and lanes 2 and 4 of panel b after SDS-polyacrylamide gel electrophoresis. Methodology and abbreviations were described in the legend to Fig. 1.

SCMV IE 94K protein was also synthesized after infection of 293 cells (Fig. 3b, lane 4).

The results of DNA replication assays for SCMV infection of permissive HF cells and untreated or retinoic acid-treated teratocarcinoma cells revealed that in all three situations, abundant viral DNA synthesis also occurred (Fig. 1b). As would be expected from the observation that 293 cells did not express HCMV IE68, these cells did not replicate input HCMV genomes (Fig. 1c), and, again, this was not altered by prior treatment with retinoic acid. Input SCMV genomes were also replicated in 293 cells, but to a slightly lower degree than in diploid HF cells (Fig. 1c). Therefore, for SCMV, both IE94 gene expression and viral DNA replication were constitutive even in undifferentiated human teratocarcinoma cells and in transformed human cells which express adenovirus E1a gene products.

The block to HCMV IE 68K polypeptide expression in

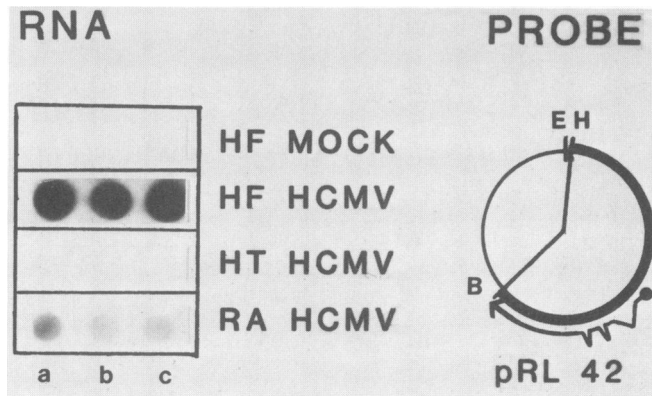

FIG. 4. IE68 RNA transcripts accumulate in infected human teratocarcinoma cells only after retinoic acid induction. RNA samples extracted from HCMV (Towne)-infected (HCMV) or mock-infected (MOCK) permissive HF cells, and from uninduced (HT) or infected retinoic acid-induced (RA) human teratocarcinoma cells were bound to nitrocellulose by an RNA dot blot procedure and hybridized with the plasmid probe pRL42 under conditions described in Materials and Methods. Spots a, b, and c represent triplicate samples (2 to 4 μ g each) of total RNA from 5×10^6 cells infected under IE conditions as defined in Materials and Methods. The amount of RNA in each spot was confirmed by methylene blue staining as described by Zinn et al. (39). Inset diagram on the right shows the pBR322-derived plasmid structure of the pRL42 probe DNA. pBR322-derived sequences are depicted by the thin line and the HCMV DNA insert containing the HCMV IE68 gene is denoted by the thick line. The splicing pattern of HCMV IE68 and direction of transcription are indicated (31).

transformed cells is at the transcriptional level. The transformed human cell lines used in these studies did not synthesize the HCMV IE 68K polypeptide, although infection of these cells did result in virus penetration and transport of input HCMV genomes to the cell nucleus. Thus, it was important to determine whether the block to IE gene expression occurred at the transcriptional or translational level in these cells. Total RNA was extracted from infected cells and hybridized with pRL42, a plasmid probe which contains the coding sequences for the HCMV IE 68K polypeptide. The results of these RNA dot blot hybridization experiments (Fig. 4) demonstrate that little, if any, HCMV IE68 mRNA was detectable in the teratocarcinoma stem cells which did not synthesize the IE 68K polypeptide. In contrast, positive hybridization to the pRL42 probe was observed with RNA samples from infected HF cells and also retinoic acid-induced human teratocarcinoma cells. We conclude that stable mRNA fails to accumulate in the teratocarcinoma stem cells before differentiation but does so after retinoic acid treatment, suggesting that the block to HCMV IE68 expression in these transformed human cells occurs at the RNA level. Similarly, infection of 293 cells did not result in IE68 RNA expression detectable by hybridization with the pRL42 probe (data not shown).

DISCUSSION

In this study, we have confirmed the observation of Gonczol et al. that human teratocarcinoma stem cells can be infected by HCMV but do not produce progeny virions (12, 13). We have localized the block in these nonpermissive human cells as occurring before IE polypeptide synthesis and suggest that it occurs at the level of IE RNA transcription. Furthermore, we have observed that SCMV IE gene

expression and DNA replication occur in these same transformed human cells.

Although there are obvious biological similarities between HCMV and SCMV, they exhibit major differences at the genome level. The HCMV DNA molecule is organized into long and short unique segments, each bounded by inverted-repeat sequences (6, 9, 10, 18, 20, 30). In contrast, SCMV has a linear genome which does not contain the long and short inverted-repeat type structure and apparently does not isomerize (20). Although the HCMV and SCMV genomes do not appear to be closely related by either size or genome organization, there is limited DNA homology (K. T. Jeang, R. L. LaFemina, and G. S. Hayward, manuscript in preparation). One such region lies in the colinear HCMV IE68 and SCMV IE94 genes, which display similar intron-exon organization (Fig. 5). The two major IE protein products are likely to be functionally similar, and common colinear domains, including a large glutamic acid-rich region, have been described (31; K. T. Jeang, T. Leitman, and G. S. Hayward, submitted for publication). The proximal region (-1 to -500 base pairs [bp]) of the 5' upstream sequences in both the HCMV IE68 and SCMV IE94 genes contain complex arrangements of four sets of homologous, highly conserved palindromic sequence elements (4, 36; K. T. Jeang, J. Mosca, and G. S. Hayward, submitted for publication). These sequences are known to be important for HCMV IE68 promoter expression in permissive cells (34). However, further studies show that a more distal SCMV IE94 upstream region (-600 to -1,300 bp) is composed of 23 copies of a tandemly repeated sequence which appears only four times in a dispersed arrangement in the HCMV IE68 promoter. These additional IE94 upstream sequences are binding sites for cellular nuclear factor 1 protein which recognizes the sequence TTGGN₆GCAA (25; D. R. Rawlins, P. J. Rosenfeld, T. J. Kelly, Jr., G. R. Milman, K.-T. Jeang, S. D. Hayward, and G. S. Hayward, *in* M. Botchan, T. Grodzicker, and P. A. Sharp (ed.), *Cancer Cells*, vol. 4. DNA tumor viruses: control of gene expression and replication, in press; Jeang et al., in preparation). This implies a role for at least one host-cell factor in determining permissiveness to CMV.

The role of cellular gene products in establishing permissiveness for CMV infection is an intriguing question which remains to be answered. However, we can speculate on how these cellular proteins affect the inducible outcome compared with the constitutive outcome for IE CMV gene expression and DNA replication in teratocarcinoma cells. Simian virus 40 and polyomavirus early gene expression is similarly repressed in murine F9 teratocarcinoma cells but is induced after retinoic acid treatment (28). Undifferentiated F9 cells express protein(s) that substitute for adenovirus E1a protein (15), and others have suggested that these cellular proteins, or E1a itself, play a role in the negative regulation of simian virus 40 and polyomavirus enhancer elements (3). Furthermore, the HCMV IE68 and SCMV IE94 promoters contain strong enhancer-like sequences (4, 36) and, as we have shown above, the HCMV IE68 mRNA and polypeptide are not detectable in virus-infected 293 cells (Fig. 3a). Since the major difference between the IE68 and IE94 promoter-regulatory sequences is the presence of the additional repeated elements in the SCMV IE94 promoter, we suggest that it may be this feature which allows this IE94 promoter to escape repression by E1a in 293 cells. However, whether adenovirus E1a or cellular E1a-like genes expressed in human teratocarcinoma cells and other transformed cells directly affect HCMV gene expression remains to be deter-

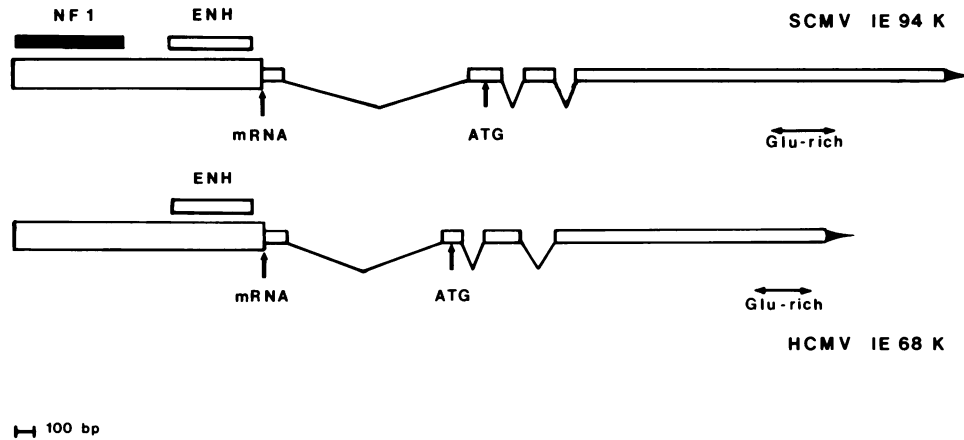

FIG. 5. Comparative organization of the HCMV IE68 gene and the SCMV IE94 gene. Thick open box represents the upstream promoter regions from -1300 to -1 bp. The locations of the mRNA start site and the first methionine codon (ATG) are indicated by arrows. The relative positions of the exons, introns, and the colinear glutamic-acid rich domains (HCMV, 23 of 46 Glu residues; SCMV 36 of 78 Glu residues) are indicated. The closed box above the SCMV promoter (-1300 to -600 bp) shows the location of 23 tandemly repeated binding sites (consensus TTGGN₆GCCAA) for cellular nuclear factor 1 (Rawlins et al., K.-T. Jeang, D. Rawlins, P. Rosenfeld, J. Shero and G. S. Hayward, manuscript in preparation). The open boxes above both the SCMV promoter (-500 to -50 bp) and the HCMV promoter (-500 to -50 bp) show the location of multiple copies of several highly conserved *cis*-acting repeated sequences which contain "enhancer" activity (4, 35). The organization of the HCMV gene is derived from other studies (31, 34, 36) and our unpublished observations. Details of the organization of the SCMV IE94 gene and its comparison to the HCMV IE68 gene will be published elsewhere (K. T. Jeang, et al., submitted for publication).

mined. A potential role for cellular oncogenes such as *c-myc* or *c-fos* in negative gene regulation of HCMV might also be suggested by the observation that altered expression of these oncogenes occurs as an early event in retinoic acid-induced cell differentiation (for example see references 23 and 26). In addition, *c-myc* and *E1a* display homologous protein domains (24) and have been placed in the same transformation complementation group (22). These hypotheses are being tested further by gene transfer and cotransfection studies.

Based on our RNA dot blot hybridization studies, we favor a direct block at the transcriptional rather than the posttranscriptional level to explain the lack of HCMV IE 68K polypeptide synthesis in these two transformed human cell lines. This is reinforced by the observation that the IE68 and IE94 genes possess essentially identical intron-exon structures and splicing signals and differ only in the distal (600-bp) promoter region. Our hypothesis that the upstream tandemly repeated regulatory sequences present in the SCMV promoter region are the major factor in determining SCMV permissiveness in these cell lines can be tested by promoter fusion studies and transfection of these chimeric genes into transformed human cells.

ACKNOWLEDGMENTS

These studies were supported by Public Health Service grants 5R01 CA22130 and 5U01 CA37314 awarded to G.S.H. from the National Institutes of Health.

We thank Peter Andrews, Eva Gonczol, and Stanley Plotkin for their gift of the NTera 2/D1 human teratocarcinoma cell line and also for their interest and advice. We thank Nancy Standish and Judy DiStefano for preparation of this manuscript and also Pamela Wright for technical assistance.

LITERATURE CITED

- Andrews, P. W. 1984. Retinoic acid induces neuronal differentiation of a cloned human embryonal carcinoma cell line *in vitro*. *Dev. Biol.* **103**:285-293.
- Andrews, P. W., I. Damjanov, D. Sunar, G. Banting, C. Carlin, N. Pracopoli, and I. Fogh. 1984. Pluripotent embryonal carcinoma clones derived from the human teratocarcinoma cell line TERA-2. *Lab. Invest.* **50**:147-162.
- Borelli, E., R. Hen, and P. Chambon. 1984. Adenovirus-2 *E1a* products repress enhancer-induced stimulation of transcription. *Nature (London)* **312**:608-612.
- Boshart, M., F. Weber, G. Jahn, K. Dorsch-Hasler, B. Fleckenstein, and W. Schaffner. 1985. A very strong enhancer is located upstream of an immediate-early gene of human cytomegalovirus. *Cell* **41**:521-530.
- Chirgwin, J. M., A. E. Przybyla, R. J. MacDonald, and W. J. Rutter. 1979. Isolation of biologically active ribonucleic acid from sources enriched in ribonuclease. *Biochemistry* **18**:5294-5299.
- DeMarchi, J. M. 1981. Human cytomegalovirus DNA: Restriction enzyme cleavage maps and map locations for immediate-early, early and late RNAs. *Virology* **114**:23-35.
- DeMarchi, J. M. 1983. Nature of the block in the expression of some early virus genes in cells abortively infected with human cytomegalovirus. *Virology* **129**:287-297.
- Dutko, F., and M. Oldstone. 1981. Cytomegalovirus causes a latent infection in undifferentiated cells and is activated by induction of cell differentiation. *J. Exp. Med.* **154**:1636-1651.
- Fleckenstein, B., I. Muller, and J. Collins. 1982. Cloning of the complete human cytomegalovirus genome in cosmids. *Gene* **18**:39-46.
- Geelen, J. L. M. C., C. Walig, P. Wertheim, and J. van der Noordaa. 1978. Human cytomegalovirus DNA. I. Molecular weight and infectivity. *J. Virol.* **26**:813-816.
- Gibson, W. 1981. Immediate-early proteins of human cytomegalovirus strains AD169, Davis and Towne differ in electrophoretic mobility. *Virology* **112**:350-354.
- Gonczol, E., P. W. Andrews, and S. A. Plotkin. 1984. Cytomegalovirus replicates in differentiated but not in undifferentiated human embryonal carcinoma cells. *Science* **224**:159-161.
- Gonczol, E., P. W. Andrews, and S. A. Plotkin. 1985. Cytomegalovirus infection of human teratocarcinoma cells. *J. Gen. Virol.* **66**:509-515.
- Graham, F. L., J. Smiley, W. C. Russell, and R. Nairn. 1977. Characteristics of a human cell line transformed by DNA from human adenovirus 5. *J. Gen. Virol.* **36**:59-72.
- Imperiale, M. J., H.-T. Kao, L. T. Feldman, J. R. Nevins, and S. Strickland. 1984. Common control of the heat shock gene and early adenovirus genes: evidence for a cellular *E1a*-like activity.

- Mol. Cell. Biol. 4:867-874.
16. Jeang, K. T., G. Chin, and G. S. Hayward. 1982. Characterization of cytomegalovirus immediate-early genes. I. Nonpermissive rodent cells overproduce the IE94K protein from CMV (Colburn). *Virology* 121:393-403.
 17. Jeang, K.-T., and W. Gibson. 1980. A cycloheximide-enhanced protein in cytomegalovirus-infected cells. *Virology* 107:362-374.
 18. Kilpatrick, B. A., and E. S. Huang. 1977. Human cytomegalovirus genome: partial denaturation map and organization of genome sequences. *J. Virol.* 24:261-276.
 19. Knowles, W. A. 1976. *In vitro* cultivation of human cytomegalovirus in thyroid epithelial cells. *Arch. Virol.* 50: 119-124.
 20. LaFemina, R., and G. S. Hayward. 1980. Structural organization of the DNA molecules from human cytomegalovirus. ICN-UCLA Symp. Mol. Cell. Biol. 18:39-55.
 21. LaFemina, R. L., and G. S. Hayward. 1983. Replicative forms of human cytomegalovirus DNA with joined termini are found in permissively infected human cells but not in non-permissive Balb/C-3T3 mouse cells. *J. Gen. Virol.* 64:373-389.
 22. Land, H., L. F. Parada, and R. A. Weinberg. 1983. Tumorigenic conversion of primary embryo fibroblasts requires at least two cooperating oncogenes. *Nature (London)* 304:596-602.
 23. Muller, R., T. Curran, D. Muller, and L. Guilbert. 1985. Induction of *c-fos* during myelomonocyte differentiation and macrophage proliferation. *Nature (London)* 314:546-548.
 24. Ralston, R., and M. D. Bishop. 1985. The protein products of the *myc* and *myl* oncogenes and adenovirus EIa are structurally related. *Nature (London)* 306:803-806.
 25. Rawlins, D. R., P. J. Rosenfeld, R. Wides, M. D. Challberg, and T. J. Kelly, Jr. 1984. Structure and function of the adenovirus origin of replication. *Cell* 37:309-319.
 26. Reitsma, P. H., P. G. Rothberg, S. M. Astrin, J. Trial, Bar-Shavit, A. Hall, S. L. Teitelbaum, and A. J. Kahn. 1983. Regulation of *myc* gene expression in HL-60 leukemic cells by a vitamin D metabolite. *Nature (London)* 306:492-494.
 27. Rowe, W. P., J. W. Hartley, S. W. Waterman, H. C. Turner, and R. J. Huebner. 1956. Cytopathogenic agent resembling human salivary gland virus recovered from tissue culture of human adenoids. *Proc. Soc. Exp. Biol. Med.* 92:418-424.
 28. Segal, S., and G. Khoury. 1979. Differentiation as a requirement for simian virus 40 gene expression in F-9 embryonal carcinoma cells. *Proc. Natl. Acad. Sci. USA* 76:5611-5615.
 29. Smith, M. G. 1956. Propagation in tissue culture of a cytopathogenic virus from human salivary gland virus (SGV) disease. *Proc. Soc. Exp. Biol. Med.* 92:424-430.
 30. Spector, D. H., L. Hock, and J. C. Tamashiro. 1982. Cleavage maps for human cytomegalovirus DNA strain AD169 for restriction endonucleases *EcoRI*, *BglIII*, and *HindIII*. *J. Virol.* 42:558-582.
 31. Stenberg, R. M., D. R. Thomsen, and M. F. Stinski. 1984. Structural analysis of the major immediate early gene of human cytomegalovirus. *J. Virol.* 49:190-199.
 32. Stinski, M. F. 1978. Sequence of protein synthesis in cells infected by human cytomegalovirus: Early and late virus-induced polypeptides. *J. Virol.* 26:686-701.
 33. Stinski, M. F., E. S. Mocarski, and D. R. Thomsen. 1979. DNA of human cytomegalovirus: size, heterogeneity and defectiveness resulting from serial undiluted passage. *J. Virol.* 31: 231-239.
 34. Stinski, M. F., and T. J. Roehr. 1985. Activation of the major immediate early gene of human cytomegalovirus by *cis*-acting elements in the promoter-regulatory sequence and by virus-specific *trans*-acting components. *J. Virol.* 55:431-441.
 35. Thomas, P. S. 1980. Hybridization of denatured RNA and small DNA fragments transferred to nitrocellulose. *Proc. Natl. Acad. Sci. USA* 77:5201-5205.
 36. Thomsen, D. R., R. M. Stenberg, W. F. Goins, and M. F. Stinski. 1984. Promoter-regulatory region of the major immediate-early gene of human cytomegalovirus. *Proc. Natl. Acad. Sci. USA* 81:659-663.
 37. Vonka, V. A., E. Anisemova, and M. Macek. 1976. Replication of cytomegalovirus in human epithelial diploid cell line. *Arch. Virol.* 52:283-296.
 38. Weller, T. H., J. C. Macauley, J. M. Craig, and P. Wirth. 1957. Isolation of intranuclear inclusion producing agents from infants with illnesses resembling cytomegalic inclusion disease. *Proc. Soc. Exp. Biol. Med.* 94:4-12.
 39. Zinn, K., D. D. Maio, and T. Maniatis. 1983. Identification of two distinct regulatory regions adjacent to the human β -interferon gene. *Cell* 34:845-879.