

Generation of Glucocorticoid-Responsive Moloney Murine Leukemia Virus by Insertion of Regulatory Sequences from Murine Mammary Tumor Virus into the Long Terminal Repeat

JOAN OVERHAUSER AND HUNG FAN*

Department of Molecular Biology and Biochemistry, University of California, Irvine, California 92717

Received 28 September 1984/Accepted 13 December 1984

The glucocorticoid-regulatory sequences from the murine mammary tumor virus long terminal repeat (MMTV LTR) were introduced into the LTR of Moloney murine leukemia virus (M-MuLV) by recombinant DNA techniques. The site of insertion was in the M-MuLV LTR U3 region at -150 base pairs with respect to the RNA cap site. Infectious M-MuLVs carrying the altered LTRs (Mo+MMTV M-MuLVs) were recovered by transfection of proviral clones into NIH-3T3 cells. The Mo+MMTV M-MuLVs were hormonally responsive in that infection was 3 logs more efficient when performed in the presence of dexamethasone, irrespective of the orientation of the inserted MMTV sequences. However, even in the presence of hormone, the Mo+MMTV M-MuLVs were less infectious than wild-type M-MuLV. In contrast to the large effect on infectivity, dexamethasone induced virus-specific RNA levels in chronically Mo+MMTV M-MuLV-infected cells only two- to fourfold. Fusion plasmids between the altered LTRs and the bacterial chloramphenicol acetyltransferase gene allowed the investigation of LTR promoter strength by the transient chloramphenicol acetyltransferase expression assay. The chloramphenicol acetyltransferase assays indicated that the insertion of MMTV sequences into the M-MuLV LTR reduced promoter activity in the absence of glucocorticoids but that promoter activity could be induced two- to fivefold by dexamethasone. The Mo+MMTV M-MuLVs were also tested for the possibility that viral DNA synthesis or integration during initial infection was enhanced by dexamethasone. However, no significant difference was detected between cultures infected in the presence or absence of hormone. The insertion of MMTV sequences into an M-MuLV LTR deleted of its enhancer sequences did not yield infectious virus or active promoters, even in the presence of dexamethasone.

Retroviruses are very useful model systems for studying the regulation of eucaryotic gene expression. The integrated viral DNA forms of these viruses (proviruses) contain long terminal repetitions (LTRs). The LTRs contain the signals for viral transcription, including promoter and enhancer elements (16, 18, 42); these elements are located in the U3 region of the LTR which is encoded by the 3' end of virion RNA. Murine mammary tumor virus (MMTV) is unique among retroviruses in that MMTV transcription is inducible by glucocorticoid hormones such as dexamethasone (32-34). As such, it has become an important system for studying glucocorticoid regulation. The sequences involved in induction have been localized and extensively mapped to the U3 region of the MMTV LTR by deletion analysis (15, 22). In addition, the U3 region of the MMTV LTR binds a glucocorticoid hormone-receptor complex in domains which overlap with the hormone-responsive sequences (28, 30, 36). In gene fusion experiments, MMTV LTR DNA fragments have conferred hormone responsiveness to heterologous genes (4, 15, 19, 22).

In the experiments reported here, MMTV hormone response sequences were inserted into the LTR of a different retrovirus, Moloney murine leukemia virus (M-MuLV). The M-MuLV LTR is well characterized and contains strong enhancer and promoter elements (16, 18, 42). The goal of these experiments was to generate a chimeric LTR which was hormonally responsive. This could be assayed in gene fusions between the chimeric LTRs and an assayable gene such as bacterial chloramphenicol acetyltransferase (CAT). Moreover, it was theoretically possible to generate an infec-

tious M-MuLV containing the chimeric LTR. Such an infectious M-MuLV would provide valuable information in addition to the LTR fusion plasmids. The infection of this M-MuLV would introduce the chimeric LTRs into normal cellular chromatin as a result of the viral infection. The physical structure of chimeric LTRs in infected cells would thus closely resemble that of normal cell hormone-responsive elements.

Here we report the initial construction and characterization of infectious M-MuLVs carrying chimeric LTRs and also LTR-CAT fusion plasmids. The insertion of MMTV sequences into the M-MuLV LTR yielded hormone-responsive LTRs as well as M-MuLVs which were hormone responsive for infectivity.

MATERIALS AND METHODS

Cell culture. Mouse NIH-3T3 cells (40) and rat XC cells (35) were grown as monolayer cultures in Dulbecco modified Eagle medium supplemented with 10% calf serum. Transfected cultures were grown in the same medium, with and without the addition of 1 μ M (final concentration) dexamethasone.

Recombinant DNA cloning. Starting plasmids for the recombinant DNA construction included (i) p63-2, a pBR322 plasmid containing an integrated M-MuLV provirus originally cloned in lambda phage (1, 6, 8); (ii) pMLV C/R/B, a pBR322 subclone of unintegrated M-MuLV DNA containing the LTR (20); (iii) pMTVdhfr, a plasmid containing the MMTV LTR promoter fused to the dihydrofolate reductase gene (19) (kindly provided by Gordon Ringold); and (iv) pM1CAT, an expression plasmid containing the M-MuLV

* Corresponding author.

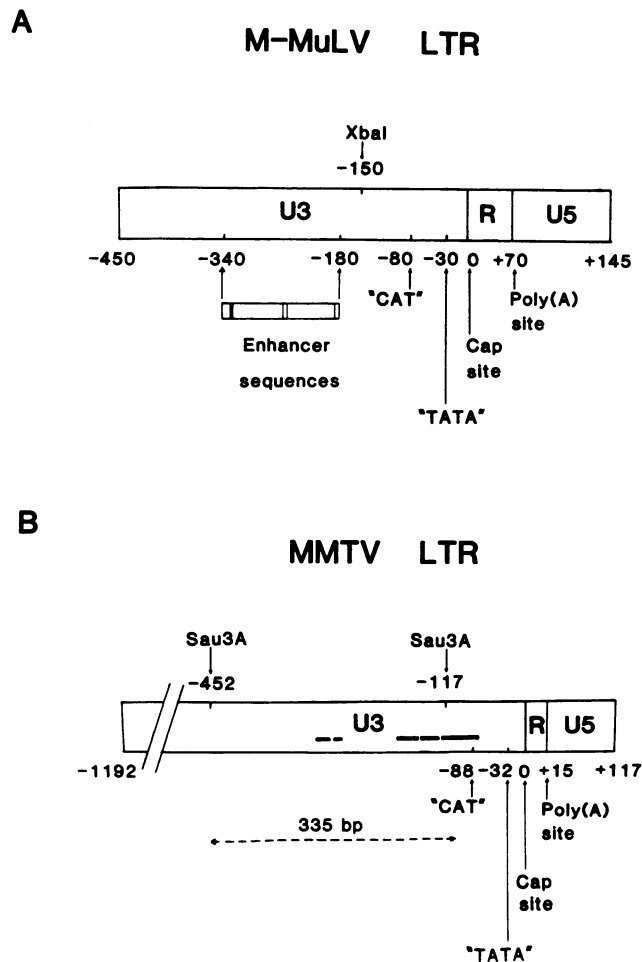

FIG. 1. Organization of M-MuLV and MMTV LTRs. (A) The wild-type LTR from a circular permuted M-MuLV proviral DNA pM-MuLV-1a (2, 42) is shown. The sequences important in proviral transcription are diagrammed. U3 contains the enhancer sequences as well as the CAT and TATA sequences involved in promoter activity. Directly 3' to the tandemly repeated enhancer sequences is located the *Xba*I site used for the insertion constructions. The cap site and the polyadenylate site define the 5' and 3' borders of the R region. (B) The LTR from a cloned MMTV provirus is shown (7). The location of the CAT and TATA sequences involved in MMTV transcription are indicated. The heavy black lines in the U3 region indicate the DNA binding regions of the hormone-receptor complex (28). The location of the 335-bp *Sau*3A fragment used for the construction of all of the chimeric LTRs is indicated. The cap site and polyadenylate site which define the R region of the MMTV LTR are also shown.

LTR linked to the bacterial CAT gene (Mo-CAT in a previous publication [20]).

In general, molecular cloning procedures were performed according to standard protocols (23).

The MMTV sequences used for all of the insertions were the 335-base-pair (bp) *Sau*3A fragment from the MMTV LTR. This fragment was isolated from pMTVdhfr DNA by preparative gel electrophoresis and blunt-end ligated with kinased *Xba*I or *Cla*I linkers (Bethesda Research Laboratories). After ligation, the DNA was phenol extracted and redigested with *Xba*I or *Cla*I, and the *Sau*3A fragment containing *Xba*I or *Cla*I cohesive ends was repurified by preparative gel electrophoresis. The fragment was then inserted into *Xba*I- or *Cla*I-digested plasmids which had

been treated with bacterial alkaline phosphatase according to standard procedures. Bacterial transformants containing the desired sequences were identified by colony hybridization (12) with a nick-translated MMTV *Sau*3A fragment probe, and insert orientation was determined by restriction mapping of DNA from miniplasmid preps (3).

DNA transfections. DNA transfections with proviral DNA organizations were performed essentially as described by Graham and van der Eb (11). Briefly, 1 μ g of plasmid DNA was mixed with 5 μ g of carrier calf thymus DNA in 0.2 ml of HEPES (*N*-2-hydroxyethylpiperazine-*N'*-2-ethanesulfonic acid)-buffered saline, and a precipitate was formed by the addition of 5 μ l of 2.5 M calcium chloride. After a 20-min incubation at room temperature, the precipitate was added to a 5-cm tissue culture dish containing 5×10^5 NIH-3T3 cells (which had been prewashed with phosphate-buffered saline at 37°C) in 4-ml growth medium containing 10 μ M chloroquine. After a 4-h incubation at 37°C, the medium was replaced with medium lacking chloroquine and incubation was continued overnight. The chloroquine was added to increase the efficiency of DNA uptake, so the transfected cells were not treated with glycerol or dimethyl sulfoxide. The next day, cells were transferred 1:5 in duplicate. After 3 to 4 h, the medium was removed and replaced with 2 ml of 20 μ g/ml Polybrene (Aldrich Chemical Co.). After 1 h of incubation, the Polybrene was removed and replaced with 4 ml of growth medium either with or without 1 μ M dexamethasone. The cells were allowed to grow to confluency. One culture was then assayed for infectious virus (see below), and the other culture was serially transferred as before.

For transient expression assays, cells were transfected with LTR-CAT plasmid DNAs as described above, except that 25 μ g of plasmid DNA without carrier was added to each 10-cm culture dish containing 10^6 NIH-3T3 cells. At 48 h after transfection, cells were assayed for bacterial CAT enzyme activity as previously described (10). Briefly, cells were harvested by scraping with a rubber policeman, and portions of clarified cell sonicates were incubated with [14 C]chloramphenicol and acetyl-CoA. Conversion of radioactive chloramphenicol to the acetylated form was monitored by ascending chromatography on Baker silica gel 1B plates in chloroform-methanol.

Virus assays. Virus stocks were 24-h tissue culture supernatants of infected cells which had been clarified by low-speed centrifugation (1,200 \times *g*; 10 min). Infectious M-MuLV titers were determined by endpoint infection on NIH-3T3 cells with the UV-XC syncytial assay (35). Virus particle concentrations were determined by harvesting virus by high-speed centrifugation and assaying for reverse transcriptase activity. An exogenous reverse transcriptase assay with polyribadenylate:oligodeoxythymidylate template primer was used (9).

Virus-specific RNA hybridization. Cytoplasmic RNA from subconfluent cultures was prepared as described previously (17). RNA dot-blot analysis was performed as previously described (39), except that RNA samples were applied to nitrocellulose sheets which had been presoaked in 20 \times SSC (1 \times SSC is 0.15 M NaCl plus 0.015 sodium citrate) but not dried. After the application of RNA, nitrocellulose sheets were baked for 2 h at 80°C in a vacuum oven and then hybridized with nick-translated probe (31) as described by Thomas (39).

Cell fractionation and DNA extraction. Cells were fractionated into nuclear and cytoplasmic fractions after disruption with 0.6% Nonidet P-40 as described previously (17). The nuclei from one half-confluent 10-cm tissue culture dish of

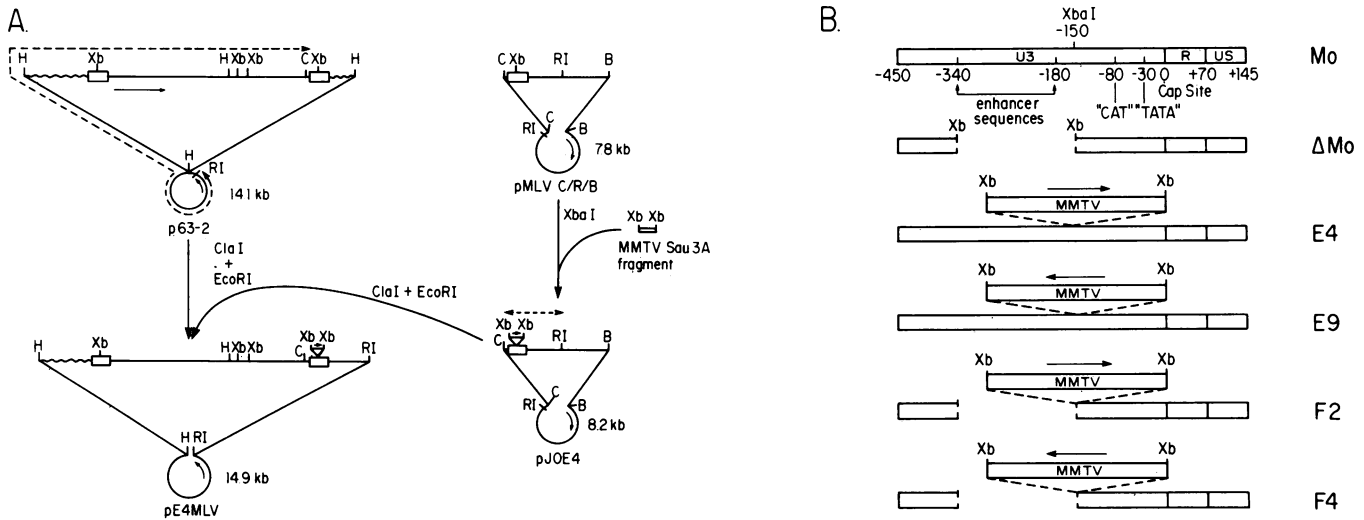

FIG. 2. Construction of M-MuLV clones containing MMTV sequences in the 3' LTR. (A) The construction of one of the M-MuLV MMTV chimeric plasmids is shown. The starting plasmids p63-2 and pMLV C/R/B have been previously described (20). pMLV C/R/B was digested with *Xba*I and treated with bacterial alkaline phosphatase. The linearized plasmid was then ligated with the MMTV *Sau*3A fragment containing *Xba*I linkers. The resulting plasmid, pJOE4, containing the MMTV fragment inserted in the positive orientation was isolated. pJOE4 and p63-2 were digested with *Eco*RI and *Cla*I. The fragments indicated with the hatched lines were isolated and ligated together, resulting in the isolation of pE4MLV. pE4MLV contains the MMTV fragment inserted into the 3' LTR. Wavy lines in the insert represent mouse cellular DNA, and the straight lines represent viral DNA. The boxes represent the wild-type LTR. Restriction endonuclease abbreviations were as follows: H, *Hind*III; Xb, *Xba*I; C, *Cla*I; RI, *Eco*RI; and B, *Bam*HI. (B) The structure of the 3' LTRs from plasmids with proviral organizations similar to pE4MLV are shown. Δ Mo contains a deletion extending from positions -335 to -150. The construction of this deleted LTR has been previously described (20). E4 and E9 are LTR structures containing the MMTV fragment inserted into the wild-type LTR in the positive and negative orientation, respectively. F2 and F4 are LTR structures containing the MMTV fragment inserted into the Δ Mo-deleted LTR in the positive and negative orientations, respectively. In all cases, the site of the insertion was at the *Xba*I site in the U3 region of the M-MuLV LTR.

cells were suspended in 0.45 ml of Tris-buffered saline lacking calcium and magnesium and lysed by the addition of sodium dodecyl sulfate (SDS) to 1%. High-molecular-weight chromosomal DNA was separated from low-molecular-weight (unintegrated viral) DNA as described by Hirt (14). DNA was extracted from the cytoplasmic, nuclear Hirt supernatant, and nuclear Hirt pellet fractions by phenol-chloroform extraction and ethanol precipitation. The DNA was further incubated with pancreatic ribonuclease (50 μ g/ml; 1 h at 37°C) followed by phenol-chloroform extraction and ethanol precipitation. The extracted DNA was suspended and stored in 0.01 M Tris (pH 8.0)–1 mM EDTA.

DNA transfer and hybridization. Southern blot transfer hybridization of agarose gels was performed as previously described (37). The baked filters were prehybridized for 2 to 6 h at 68°C in prehybridization buffer consisting of 5 \times SSC, 10 \times Denhardt solution, 0.05 M phosphate buffer (pH 6.5), 1% glycine, and 100 μ g of denatured salmon sperm DNA per ml. Hybridization was performed for 12 to 18 h at 68°C in hybridization buffer containing 5 \times SSC, 5 \times Denhardt solution, 0.04 M phosphate buffer (pH 6.5), 0.2% SDS, 100 μ g of denatured salmon sperm DNA per ml, and 10⁶ cpm of denatured nick-translated probe per ml. After hybridization, filters were washed once in 2 \times SSC–1% SDS (1/2 h at room temperature with agitation) and once in 0.1 \times SSC–1% SDS (2 h at 65°C with agitation) before drying and autoradiography at -70°C with an intensifying screen.

RESULTS

Construction of M-MuLV LTR clones containing MMTV sequences. As the first step in these experiments, glucocorticoid-regulatory sequences from the MMTV LTR were

inserted into an LTR subclone of M-MuLV DNA. The MMTV fragment chosen was a *Sau*3A fragment (-452 to -117 bp with respect to the cap site) from the MMTV LTR (Fig. 1B). This fragment contains sequences necessary for glucocorticoid regulation of the MMTV promoter (15, 22), and it has been shown to confer a glucocorticoid response to a heterologous promoter in gene fusion experiments (4). In addition, the *Sau*3A fragment contains most of the MMTV LTR binding sites for the glucocorticoid receptor (Fig. 1B) (28, 36).

The M-MuLV LTR subclone used as a cloning vehicle was pMLV C/R/B (Fig. 2A [20]). pMLV C/R/B is a subclone of unintegrated M-MuLV viral DNA containing one copy of the M-MuLV LTR (Fig. 1A) and extending from the *Cla*I site at 7.7 kb at the 3' end of the viral genome through the *Bam*HI site at 3.2 kilobases (kb) at the 5' end of the viral map. In addition, the *Xho*I site at 1.6 kb on the proviral map was converted to an *Eco*RI site. The MMTV *Sau*3A fragment was inserted via *Xba*I linkers into the unique *Xba*I site of pMLV C/R/B located at -150 bp in the LTR with respect to the cap site (Fig. 1A). The *Xba*I site lies between the M-MuLV promoter and the enhancer sequences. We previously showed that polyomavirus sequences (250 bp) could be inserted at the *Xba*I site without the loss of LTR function (20; B. R. Davis, E. Linney, and H. Fan, submitted for publication). Insertions were also made in an analogous fashion into a deleted M-MuLV LTR, Δ Mo (20). This LTR contained a deletion encompassing the M-MuLV enhancer sequences and is inactive (20). Insertions into the Δ Mo LTR were made to determine whether the MMTV *Sau*3a fragment could functionally substitute for deleted M-MuLV enhancer sequences. The names and organizations of the chimeric LTRs are shown in Fig. 2B.

TABLE 1. Virus production after DNA transfection by M-MuLV containing altered 3' LTRs^a

DNA	Results of transfection with:				
	DEX	TR.1	TR.2	TR.3	TR.4
p63-2	-	++++	C	C	C
	+	++++	C	C	C
pΔMoMLV	-	-	+	++++	C
	+	-	+	++++	C
pE4MLV	-	+	++++	C	C
	+	+++	++++	C	C
pE9MLV	-	++	++++	C	C
	+	+++	++++	C	C
pF2MLV	-	-	+	++++	C
	+	-	++	++++	C
pF4MLV	-	-	+++	C	C
	+	+	+++	C	C

^a DNAs containing various LTRs (Fig. 2B) were transfected onto NIH-3T3 cells by the calcium phosphate method. After transfection, the cells were continuously grown either in the presence or absence of 1 μM dexamethasone (DEX). The cells were transferred (1:5) in duplicate 1 day after transfection and scored for the production of virus by the UV-XC assay upon reaching confluency (transfer 1 [TR.1]). The duplicate plate was continually passaged (1:5) and scored for the production of virus after each transfer. The data shown represent an average of four separate transfection experiments with two different sets of plasmid DNA. The number of XC plaques observed are as follows: -, 0 XC plaques; -/+, 1 to 10 XC plaques; +, 10 to 50 XC plaques; ++, 50 to 100 XC plaques; +++, 100 to 500 XC plaques; +++++, plate covered with isolated XC plaques; and C, plate confluent with XC syncytia.

Construction and transfection of M-MuLV proviral DNA containing altered 3' LTRs. The construction of an M-MuLV proviral DNA containing a chimeric 3' LTR is briefly diagrammed in Fig. 2A. Ligation of the *Clal* to *EcoRI* fragment from the chimeric pMLV C/R/B derivative into a plasmid containing a complete integrated M-MuLV provirus (p63-2) resulted in the desired organization. For example, the E4 chimeric LTR (containing the MMTV fragment inserted into the wild-type M-MuLV LTR in the positive orientation) gave rise to the proviral derivative pE4MLV.

Proviral DNA transfection involves the spread of infectious virus from the initially transfected cell to neighboring cells (5). The MMTV insertions in the chimeric LTRs of Fig. 2B were in the U3 region; secondarily infected cells would be infected by virus containing the chimeric sequences in the U3 region of the RNA. This would result in secondarily infected cells (the majority in a transfected culture) containing M-MuLV proviruses with chimeric LTRs at both the 5' and 3' ends.

Transfections of various proviral plasmids into mouse NIH-3T3 cells are summarized in Table 1. The initially transfected cultures were serially transferred, and duplicate cultures at each transfer were assayed for the production of M-MuLV by the UV-XC assay. Each transfection was performed in the presence and absence of 1 μM dexamethasone. For comparison, transfection with a plasmid containing a wild-type M-MuLV provirus (p63-2) as well as a plasmid containing a 3' ΔMo LTR was also performed. Transfection of pE4MLV and pE9MLV DNAs (MMTV insertions into the wild-type M-MuLV LTR) showed XC plaques on the first transfer, although at a somewhat lower efficiency than what was observed with transfection by p63-2 DNA. However, considerably more XC plaques were observed for pE4MLV and pE9MLV when the transfections were performed in the presence of dexamethasone, suggesting that the resulting viruses were hormonally responsive. Transfection with pF2MLV and pF4MLV DNAs (MMTV

insertions into the ΔMo LTR) also showed XC plaques, although at a much reduced efficiency. Transfection with pΔMoMLV DNA gave no XC plaques on the first cell transfer, which was consistent with the inactivity of the ΔMo LTR. However, infectious virus was eventually recovered in subsequent transfers. The eventual infection of the pΔMoMLV-transfected cultures suggested that replication-competent M-MuLV might arise at a low frequency by DNA-DNA recombination to give a wild-type M-MuLV provirus during transfection.

To test the nature of the viruses in the transfected cultures, cytoplasmic RNA was extracted from cultures which had been passaged until they were uniformly XC positive. RNA dot-blot analysis with nick-translated M-MuLV and MMTV DNA probes is shown in Fig. 3. All of the transfected cell cultures contained approximately the same amount of M-MuLV-specific RNA as was measured by the M-MuLV-specific probe. Hybridization with the MMTV-specific probe, however, yielded some unexpected results. Although p63-2-transfected cells showed no MMTV sequences as expected, neither did cells transfected with pF2MLV or pF4MLV, even when transfected and grown in the presence of dexamethasone. This suggested that the latter cultures were infected only with a recombinant M-MuLV lacking MMTV sequences. Cells from the pE4MLV and pE9MLV transfections did indeed contain MMTV sequences. However, although the two cultures contained the same amount of M-MuLV-specific RNA as measured by the M-MuLV DNA probe, the pE9MLV-transfected culture contained four- to eightfold more MMTV-specific RNA than did the pE4MLV-transfected culture. This indicated that at least the pE4MLV-transfected culture contained a mixture of M-MuLV containing MMTV as well as M-MuLV lacking MMTV sequences.

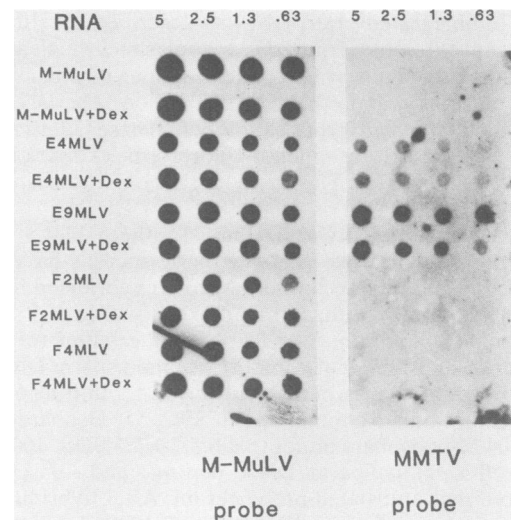

FIG. 3. RNA dot-blot analysis of RNA from cells transfected with the 3' LTR plasmids. NIH-3T3 cells were transfected with the various chimeric plasmids either in the presence or absence of 1 μM dexamethasone. After the cells were uniformly XC positive, total cytoplasmic RNA was isolated from subconfluent plates and dotted onto nitrocellulose. Duplicate filters were made. One filter was hybridized with a nick-translated pMLV C/R/B probe, and the other filter was hybridized with the nick-translated pUCMMTV plasmid. pUCMMTV is a pUC12 derivative containing the MMTV fragment inserted into the unique *XbaI* site of pUC12.

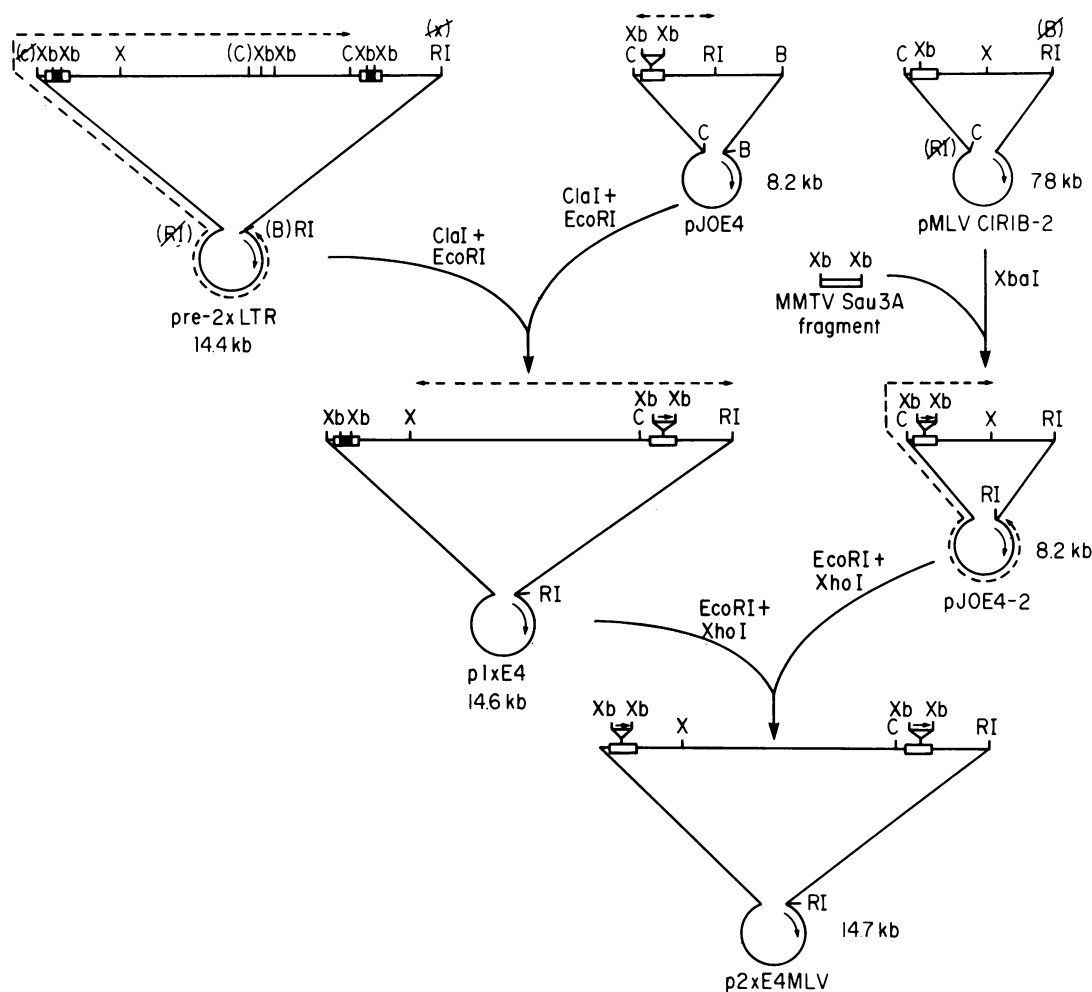

FIG. 4. Construction of M-MuLV plasmids containing 5' and 3' chimeric LTRs. The construction of one recombinant plasmid containing alterations in both the 5' and 3' LTRs is shown. The plasmid pJOE4 has been described in a previous figure. pMLV C/R/B-2 and pre-2XLTR are described in the text. pMLV C/R/B-2 was digested with *Xba*I and treated with bacterial alkaline phosphatase. The linearized plasmid was ligated in the presence of the MMTV *Sau*3A fragment containing the *Xba*I linkers. The transformants were screened for orientation, resulting in the isolation of pJOE4-2. pre-2XLTR and pJOE4 were digested with *Cla*I and *Eco*RI. The fragments indicated by hatched lines were isolated and ligated together, resulting in the plasmid p1XE4 which contains the chimeric LTR at the 3' end. p1XE4 and pJOE4-2 were digested with *Eco*RI and *Xho*I. The appropriate fragments were then isolated and ligated together, resulting in the plasmid p2xE4MLV. This plasmid contains MMTV sequences in the positive orientation in both LTRs. Plasmids containing the E9, Δ Mo, and F4 LTR structures were constructed in the same manner. The boxes in the insert sequences represent the location of the LTR sequences. The darkened areas within the LTRs represent the polyoma and immunoglobulin sequences present in the pre-2XLTR. Restriction endonuclease abbreviations were as follows: H, *Hind*III; Xb, *Xba*I; X, *Xho*I; C, *Cla*I; RI, *Eco*RI; and B, *Bam*HI. The restriction sites in parentheses represent a restriction site that is not cleaved due to methylation. A restriction site that is in parentheses with a slash through it represents a restriction site that has been deleted.

The transfection results indicated that M-MuLVs containing the MMTV fragment inserted into the wild-type LTR in either orientation were viable, although perhaps with lowered growth potential. The complete absence of MMTV sequences in cultures transfected with pF2MLV and pF4MLV suggested that the MMTV fragment could not functionally replace the M-MuLV enhancer sequences, even in the presence of dexamethasone.

Construction and transfection of M-MuLV proviral organizations containing 5' and 3' chimeric LTRs. The results of Fig. 3 indicated that the appearance of recombinant M-MuLV lacking chimeric LTRs during transfection was a serious concern. The recombinant M-MuLV was probably wild-type M-MuLV resulting from recombination between two transfecting DNA molecules, yielding an M-MuLV

provirus with wild-type LTRs at both ends (indicated by Southern blot analysis of transfected cultures; data not shown). To circumvent this problem, plasmids containing M-MuLV proviral organizations with chimeric LTRs at both 5' and 3' sides were constructed. The scheme for the construction of these plasmids is shown in Fig. 4.

Two intermediate plasmids facilitated the construction of plasmids with two chimeric LTRs. One plasmid, pMLV C/R/B-2, was a derivative of pMLV C/R/B which contained a unique *Eco*RI site at the former *Bam*HI site of pMLV C/R/B as well as the original M-MuLV *Xho*I site. The other plasmid, pre-2XLTR, was obtained from a series of constructions which resulted in an M-MuLV proviral organization complete with 5' and 3' LTRs. Important features of pre-2XLTR were unique sites for *Xho*I, *Eco*RI, and *Cla*I. (There

TABLE 2. Specific infectivity of M-MuLV proviral organizations containing 5' and 3' chimeric LTRs^a

DNA	Virus titer (PFU/μg) of DNA in:	
	-DEX	+DEX
p63-2	5 × 10 ⁵	10 ⁶
p2XΔMoMLV	0	0
p2XE4MLV	0	6 × 10 ²
p2XE9MLV	2	10 ³
p2XF4MLV	0	0

^a DNA transfections onto NIH-3T3 cells with 0.001, 0.01, 0.1, and 1 μg of various M-MuLV plasmid DNAs were performed. The cells were continuously grown either in the presence (+DEX) or absence (-DEX) of 1 μM dexamethasone. The cells were transferred 1:5 1 day after transfection (before the spread of infectious virus) and scored for virus production by the UV-XC assay method after reaching confluency. The values indicated represent calculated XC PFU per microgram of transfecting DNA.

were actually two *Cla*I sites within the M-MuLV sequences corresponding to 5.0 and 7.7 kb on the proviral map; however, plasmid grown in *Escherichia coli* contains methylation at the *Cla*I 5.0-kb site. Thus, the *Cla*I 7.7-kb site was functionally a unique site.) In addition, both LTRs were marked by the insertion of 250 bp of polyomavirus sequences in the 5' LTR and 340 bp of mouse immunoglobulin enhancing sequences in the 3' LTR. This allowed the easy verification of various LTR substitutions. In Fig. 4, the region containing the altered sequences was transferred from pJOE4 (pMLV C/R/B containing the E4 chimeric LTR) into pMLV C/R/B-2 and subsequently into pre-2XLTR. The appropriate regions of these two plasmids were then combined to yield the final plasmid containing E4 LTRs at both ends (p2XE4MLV). Similar constructions were performed for the E9, F4, and ΔMo LTRs.

Plasmid DNAs containing the proviral organizations with both 5' and 3' altered LTRs were transfected into NIH-3T3 cells in the presence and absence of dexamethasone, and cells were passaged 1:5 after 1 day. At confluency, one plate from each transfection was assayed for the presence of virus by UV-XC overlay followed by the counting of XC plaques. Results from a typical experiment are shown in Table 2. In the absence of dexamethasone, only transfections with p63-2 (containing wild-type M-MuLV provirus) showed high levels of XC plaques. p2XE9MLV consistently showed a few plaques in various experiments, whereas p2XE4MLV only occasionally showed plaques. However, the presence of dexamethasone in the transfected cultures resulted in a dramatic increase in XC plaques for both p2XE9MLV and p2XE4MLV (ca. 500-fold). The transfection of p63-2 DNA also showed a slight (twofold) increase of XC plaques in the presence of dexamethasone. However, no plaques were ever detected in transfections with p2XF4MLV or p2XΔMoMLV in either the presence or absence of dexamethasone.

The transfected cultures described in Table 2 were serially transferred for several passages, and duplicate plates from each transfer were assayed for XC plaques. This was done to allow for the detection of poorly infectious virus which might not have been detected by the XC assay of the first transfer. The results are shown in Table 3. No XC plaques were detected in cells transfected with either p2XF4MLV or p2XΔMoMLV, even after four transfers. This was consistent with the previously reported lack of promoter activity of the ΔMo LTR (20) as well as the RNA analysis of pF4MLV-transfected cells in which only the 3' LTR was chimeric (Fig. 3). This result confirmed the necessity of generating these

plasmids to avoid recombination to replication-competent M-MuLV.

The serial transfer of a p2XE4MLV-transfected culture in the absence of dexamethasone eventually yielded a culture confluent with XC plaques, even though the first transfers of the culture rarely showed any plaques (Table 3). Similarly, p2XE9MLV-transfected cultures also eventually became confluent with XC plaques when passaged in the absence of dexamethasone. The virus in these cultures most likely contained the desired chimeric LTRs, since no wild-type LTRs were present for recombination. This was confirmed by Southern blot analysis of infected cell DNA (see below). Tissue culture supernatants from the cultures serially transferred in the absence of dexamethasone were also used as the source for infectious virus in experiments described below. The viruses are referred to as Mo+MMTV⁺ M-MuLV (from DNA transfections with plasmids containing the E4 type LTR) and Mo+MMTV⁻ M-MuLV (containing the E9 type LTR).

Infectivity of chimeric viruses. The DNA transfection experiments suggested that the Mo+MMTV M-MuLVs had greater infectivity in the presence of dexamethasone. This was directly tested by performing infectivity titrations for Mo+MMTV⁺ M-MuLV and Mo+MMTV⁻ M-MuLV on NIH-3T3 cells in the presence and absence of dexamethasone (Table 4). The titration of the same viral stocks showed titers that were 3 logs higher in the presence of dexamethasone; wild-type M-MuLV showed only a sixfold higher titer. This confirmed that the chimeric viruses were hormone responsive. However, even in the presence of dexamethasone, the Mo+MMTV M-MuLV virus stocks showed 500-fold lower titers than did wild-type M-MuLV stocks. One possible explanation was that the Mo+MMTV M-MuLV stocks contained fewer virus particles than did the wild-type M-MuLV stocks. Therefore, the amount of virus particles present in the virus stocks was measured by reverse transcriptase assay (Table 4). The Mo+MMTV M-MuLV virus stocks contained four- to fivefold less virus particles than did the wild-type M-MuLV stock. Therefore, even in the presence of dexamethasone, the specific infectivities of the Mo+MMTV M-MuLVs were 100-fold lower than the specific infectivity of wild-type M-MuLV. This indicated that even when assayed in favorable conditions, the Mo+MMTV M-MuLVs were less infectious than wild-type M-MuLV.

Dexamethasone induction of infected cells. The virus infection studies demonstrated that the Mo+MMTV M-MuLVs were hormone responsive for infection, and it seemed likely

TABLE 3. Virus production after DNA transfection with M-MuLV DNA containing 5' and 3' chimeric LTRs^a

DNA	Results of transfection with:				
	DEX	TR.1	TR.2	TR.3	TR.4
p63-2	-	++++	C	C	C
	+	++++	C	C	C
p2XΔMoMLV	-	-	-	-	-
	+	-	-	-	-
p2XE4MLV	-	-	++	++++	C
	+	+++	++++	C	C
p2XE9MLV	-	-/+	+++	C	C
	+	+++	++++	C	C
p2XF4MLV	-	-	-	-	-
	+	-	-	-	-

^a Analysis of virus production was performed as described in footnote a, Table 1, except the transfected plasmids had altered 5' and 3' LTRs.

TABLE 4. Infectivity of Mo+MMTV M-MuLV^a

Virus	Virus titer (PFU/ml) in:		No. of virus particles ^b	Adjusted virus titer (PFU/ml) ^c		+DEX/-DEX ^d
	-DEX	+DEX		-DEX	+DEX	
M-MuLV	1.4×10^6	8.3×10^6	1.0	1.4×10^6	8.3×10^6	5.9
Mo+MMTV ⁺ M-MuLV	1.2×10^1	1.4×10^4	0.24	5.0×10^1	5.8×10^4	1.16×10^3
Mo+MMTV ⁻ M-MuLV	6.0×10^0	1.2×10^4	0.20	3.0×10^1	6.0×10^4	2.0×10^3

^a The virus titer was determined by making various dilutions of a 24-h clarified supernatant from productively infected cells grown in the absence of dexamethasone and infecting NIH-3T3 cells which had been pretreated for 1 h with 20 μ g of Polybrene per ml with 1 ml of diluted viral supernatant. After 1 h of incubation, 8 ml of growth medium (either with or without 1 μ M dexamethasone) was added. The cells were scored for virus production by the UV-XC assay method after 4 days.

^b The number of virus particles present in the viral supernatant was determined by reverse transcriptase activity of the same viral supernatant. Reverse transcriptase activity was normalized to the M-MuLV viral stock. Reverse transcriptase activity for M-MuLV normally ranged from 1×10^6 to 2×10^6 cpm of pelleted viral supernatant per ml.

^c The virus titer was adjusted by dividing the virus titer by the normalized virus particle number.

^d This number was obtained by dividing the adjusted virus titer obtained in the absence of dexamethasone (-DEX) by the adjusted virus titer obtained in the presence of dexamethasone (+DEX).

that this was the result of hormone-responsive proviral transcription. This was tested by measuring virus-specific RNA levels in infected cells. NIH-3T3 cells were infected with Mo+MMTV M-MuLVs in the absence of dexamethasone and passaged until confluent. Duplicate cultures were then grown in the presence or absence of dexamethasone for 48 h, and then cytoplasmic RNA was prepared. Dot-blot analysis of the cytoplasmic RNAs is shown in Fig. 5. Wild-type and Mo+MMTV M-MuLV-infected cells contained similar levels of M-MuLV-specific RNA, although Mo+MMTV⁺ M-MuLV-infected cells generally showed slightly lower levels of viral RNA. Dexamethasone treatment of wild-type M-MuLV-infected cells did not affect the viral RNA level. In contrast, treatment of Mo+MMTV M-MuLV-infected cells with dexamethasone increased the virus-specific RNA levels two- to fourfold, which was consistent with the hormone responsiveness of these viruses. However, the two- to fourfold increase in virus-specific RNA after dexamethasone treatment was in marked contrast to the 3-log difference in viral infectivity described above. When virus released in 24 h into growth medium from cultures grown in the presence and absence of dexamethasone was quantified by reverse transcriptase activity, two- to threefold increase was seen in culture supernatants from the induced plates, which was consistent with the increase observed for the virus-specific RNA levels.

Transient expression assays for LTR promoter activity. One possible explanation for the discrepancy in the magnitude of the dexamethasone effect between the cellular RNA measurements (Fig. 5) and infectivity measurements (Table 4) could be the fact that steady-state RNA levels were measured in Fig. 5. If virus-specific RNA in the infected cells turned over slowly, it is possible that the virus-specific RNA could have accumulated over several cell generations. As a result, even if hormone treatment had a large effect on the viral transcription rate, it might result in only a small increase in the steady-state virus-specific RNA level at 24 h. Therefore, experiments were performed to measure the transcriptional promoter activity of the chimeric LTRs more directly.

Promoter activity of the LTRs was measured by generating DNA fusions between the LTR promoter sequences and the bacterial CAT gene, followed by the transfection and assay for the transient expression of CAT enzyme (10). The organization of the LTR-CAT plasmids is shown in Fig. 6. The generation of CAT plasmid containing the wild-type M-MuLV promoter (pM1CAT) as well as the Δ Mo LTR (p Δ MoCAT) has been described previously (10). CAT plas-

mids containing LTRs equivalent to the E4, E9, F2, and F4 chimeric LTRs were generated by recloning the MMTV *Sau3A* fragment (via *Xba*I linkers) into pM1CAT and p Δ MoCAT. Two additional CAT constructs were also generated in which the MMTV *Sau3A* fragment was introduced in either orientation (via *Cla*I linkers) into pM1CAT at the *Cla*I site (pG1CAT and pG2CAT). The *Cla*I site is located 140 bp to the 5' side of the M-MuLV LTR; in this construction the M-MuLV LTR was not disrupted by the MMTV sequences.

The LTR-CAT plasmids were transfected into NIH-3T3 cells, and cell extracts were measured for CAT enzyme activity after 48 h. Duplicate cultures were induced with dexamethasone at the time of transfection and also measured for CAT activity (Fig. 7 and Table 5). In the absence of dexamethasone, extracts from the pE4CAT- and pE9CAT-transfected cells showed considerably less activity (ca. 10-fold less) than did wild-type pM1CAT, although the basal activity detected was significant. In the presence of dexamethasone, CAT activity increased two- to fourfold from the

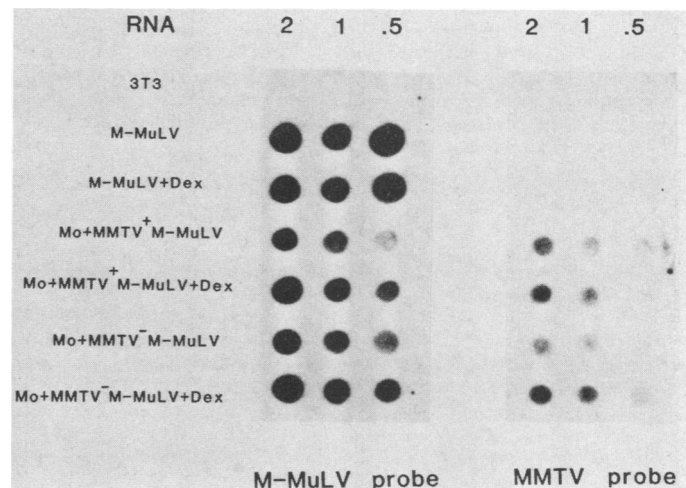

FIG. 5. Dexamethasone induction of viral RNA from Mo+MMTV M-MuLV-infected cells. NIH-3T3 cells transfected with p63-2, 2XE4M-MuLV, and 2XE9M-MuLV (which were confluent XC positive and grown in the absence of dexamethasone) were passaged 1:5. To duplicate the plates, 1 μ M dexamethasone was added, and total cytoplasmic RNA was harvested 48 h later. Blotting and hybridization were performed in the same manner as described in the legend to Fig. 2.

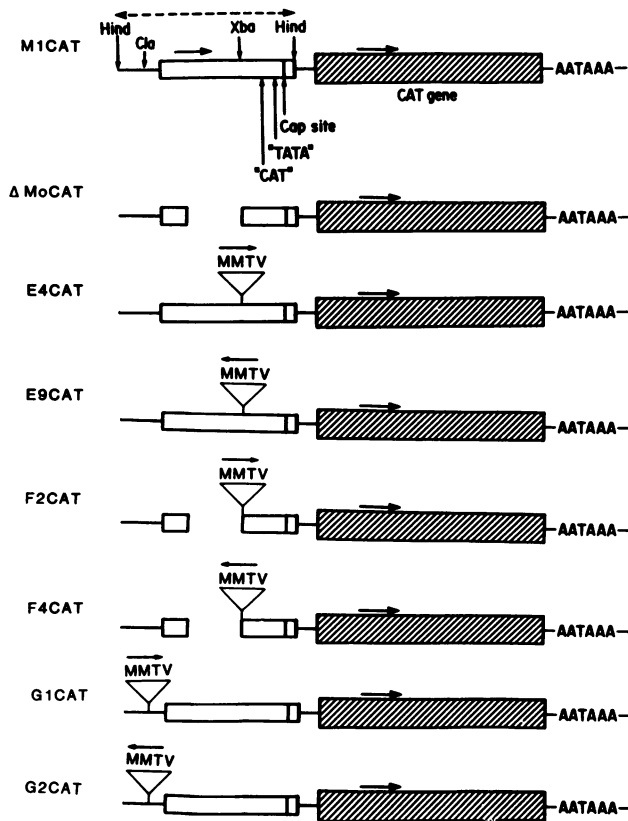

FIG. 6. Construction of LTR-CAT plasmids. The construction of the initial LTR-CAT plasmids pM1CAT and pΔMoCAT have been previously described (20). pM1CAT contains the *Eco*RI-to-*Sma*I M-MuLV fragment from pMLV C/R/B which had been inserted into pUCCATpA2 (20) via blunt-end ligation and *Hind*III linkers. pUCCATpA2 is a pUC12 derivative containing the CAT gene that is lacking its own promoter (21). The M-MuLV fragment contains the M-MuLV enhancer sequences and the promoter sequences. The *Sma*I site is located at +30 in the U5 region. To construct the various LTR-CAT plasmids, either pM1CAT or pΔMoCAT were digested with *Xba*I, treated with bacterial alkaline phosphatase, and then ligated with the MMTV fragment. Orientation of the inserted fragment was then determined. The *Cla*I site constructions were performed in the same manner. The name and structure of the various LTR-CAT constructs are diagrammed.

TABLE 5. Transient expression analysis of the LTR-CAT plasmids^a

Plasmid	% Acetylation		Fold induction with dexamethasone
	-DEX	+DEX	
pM1CAT	48.4	46.1	0.95
pE4CAT	3.2	8.1	2.53
pE9CAT	5.1	14.2	2.78
pG1CAT	2.6	8.9	3.42
pG2CAT	13.6	68.4	5.03
pΔMoCAT	0.23	0.28	1.22
pM1CAT	25.9	27.3	1.07
pF2CAT	0.24	0.23	0.96
pF4CAT	0.24	0.26	1.08

^a The appropriate spots (Fig. 7) were cut from the silica gel, the amount of radioactivity was determined, and the percent acetylation was calculated. -DEX, cells grown in the absence of dexamethasone; +DEX, cells grown in the presence of dexamethasone.

pE4CAT- and pE9CAT-transfected cells, although little hormone induction was observed from the pM1CAT-transfected cells. These results suggested that transcription from the promoters in the E4 and E9 LTRs was induced ca. threefold by dexamethasone, which was consistent with the steady-state RNA measurements. Thus, the discrepancy between the magnitudes of induction observed by cytoplasmic RNA analysis versus virus titration did not appear to result from an underestimate of transcriptional induction by steady-state RNA analysis.

The insertion of the MMTV fragment at the *Cla*I site outside of the M-MuLV LTR also reduced promoter activity, although not quite to the same extent for pG2CAT as did insertion within the M-MuLV LTR. Moreover, the MMTV fragment in this location also conferred hormone responsiveness, and the magnitude of induction was also three- to fivefold. Thus, the MMTV fragment could confer hormone responsiveness to the M-MuLV LTR when located at a different position than the *Xba*I site within the M-MuLV LTR.

The F2 and F4 CAT plasmids showed no activity when transfected either in the presence or absence of dexamethasone. This supported the viral DNA transfection experiments in which no virus could be obtained from p2XF4MLV DNA. This further suggested that the MMTV *Sau*3A frag-

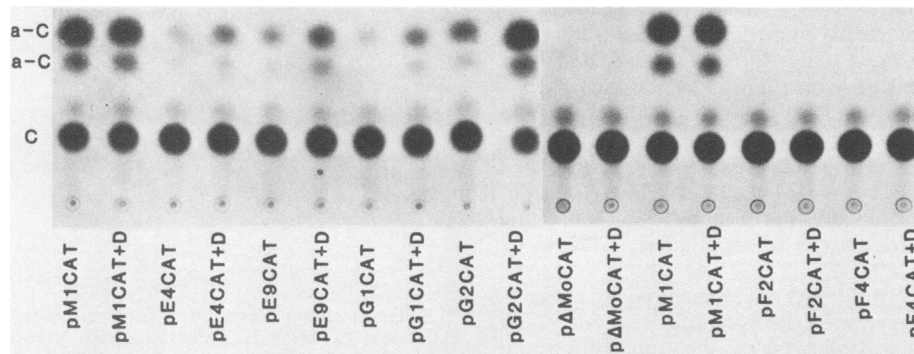

FIG. 7. Transient expression analysis of the LTR-CAT plasmids. NIH-3T3 cells were transfected with the various plasmids in either the presence or absence of dexamethasone. Cells were harvested 48 h later and analyzed for CAT activity. An autoradiogram of typical silica gel plates after thin-layer chromatography is shown. The location of the starting substrate [¹⁴C]chloramphenicol (C) is shown. The two acetylated forms of chloramphenicol (a-C) are also indicated. The D after the plasmid name represents samples in which the cells were transfected and grown in the presence of dexamethasone.

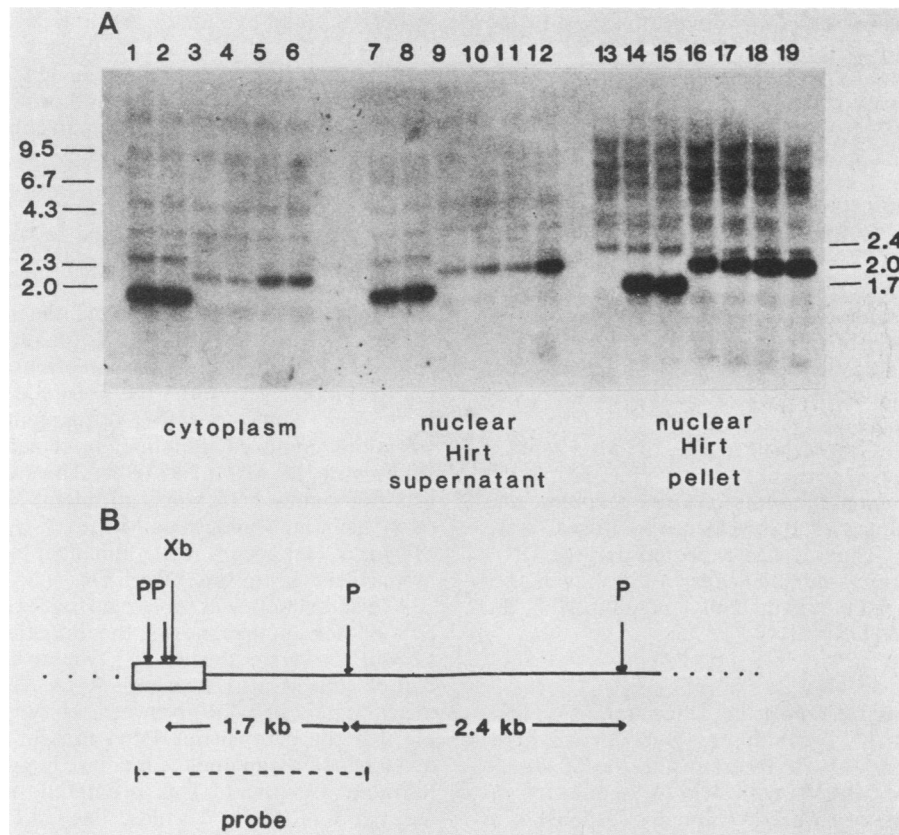

FIG. 8. Analysis of viral DNA replication and integration. (A) DNA was isolated from the cytoplasmic fraction (lanes 1 to 6), the nuclear Hirt supernatant (lanes 7 to 12), and the nuclear Hirt pellet (lanes 14 to 19) from cells 24 h postinfection. One-tenth of each DNA sample was digested with *PvuII* and subjected to electrophoresis on a 0.8% agarose minigel for 3 h at 50 V. The gels were blotted onto nitrocellulose and hybridized with an M-MuLV-specific probe (Fig. 8B) as described in the text. The location of *HindIII*-digested lambda DNA fragments are shown. The size of the M-MuLV-specific bands are indicated at the right of the autoradiogram. The DNA samples in lanes 1 to 19 were isolated from the following cells: cells infected with M-MuLV (lanes 1, 7, and 14); cells infected with M-MuLV in the presence of dexamethasone (lanes 2, 8, and 15); cells infected with Mo+MMTV⁺ M-MuLV (lanes 3, 8, and 16); cells infected with Mo+MMTV⁺ M-MuLV in the presence of dexamethasone (lanes 4, 9, and 17); cells infected with Mo+MMTV⁻ M-MuLV (lanes 5, 10, and 18); cells infected with Mo+MMTV⁻ M-MuLV in the presence of dexamethasone (lanes 6, 11, and 19); and uninfected NIH-3T3 cells (lane 13). (B) The location of the M-MuLV-specific probe used for the hybridization in Fig. 8A is shown. The 5' region of M-MuLV is shown with the box representing the LTR sequences. The location of the *PvuII* (P) and *XbaI* (Xb) sites are indicated. The dashed line represents the sequences present in the nick-translated fragment used for the Southern blot analysis. The sizes of the expected M-MuLV *PvuII*-digested fragments are indicated.

ment is not able to functionally substitute for the M-MuLV enhancer sequences (deleted from these LTRs) either in the presence or absence of dexamethasone.

Synthesis and integration of viral DNA. Another possible explanation for the large magnitude of dexamethasone induction observed in the viral infection experiments was that dexamethasone also enhanced synthesis or integration of viral DNA (or both) during the initial infection by Mo+MMTV M-MuLVs. To test this hypothesis, NIH-3T3 cells were infected in the presence and absence of dexamethasone with equivalent amounts (as measured by reverse transcriptase activity) of wild-type, Mo+MMTV⁺, or Mo+MMTV⁻ M-MuLV at low multiplicity. Twenty-four hours after infection, cells were fractionated into cytoplasm and nuclei. Cytoplasmic and nuclear DNA was extracted, and nuclear low-molecular-weight DNA was separated from nuclear high-molecular-weight DNA by the Hirt extraction procedure (14). Unintegrated viral DNA would be expected to be found in cytoplasmic and nuclear Hirt supernatant DNA, and integrated proviral DNA would be expected to be found in the nuclear Hirt pellet DNA. Thus, by analyzing the

amount of viral DNA in each of these fractions, any differences in either the viral DNA synthesis rate or integration after hormone treatment could be detected. The DNA samples from the cytoplasmic fraction, the nuclear Hirt supernatant, and the nuclear Hirt pellet were digested with *PvuII* (Fig. 8A). The minigels were used to allow analysis from a relatively small number of infected cells (less than one infected 10-cm tissue culture dish). The nick-translated probe used was specific for the 5' end of the M-MuLV provirus (Fig. 8B) and would detect a 1.7-kb fragment from wild-type M-MuLV provirus and a 2.0-kb fragment from Mo+MMTV M-MuLV proviruses. Dexamethasone did not affect the relative amounts of virus-specific DNA in the various cell fractions for cells infected with either M-MuLV or Mo+MMTV⁺ M-MuLV, although cells infected with wild-type M-MuLV showed more viral DNA in all fractions than did Mo+MMTV M-MuLV-infected cells (Fig. 8A). Mo+MMTV⁻ M-MuLV showed a slight increase in the level of unintegrated DNA in the nuclear Hirt supernatant DNA sample with the addition of dexamethasone. However, this result was variable and never showed greater than a

twofold increase. This increase was never observed in the cytoplasmic fraction or the nuclear Hirt pellet fraction.

These results indicated that dexamethasone never greatly affected the relative rates of viral DNA synthesis or integration in Mo+MMTV M-MuLV-infected cells.

One possible artifact in the experiment of Fig. 8 could have been if unintegrated viral DNA were trapped in the nuclear Hirt pellet DNA. If this amount of putative contaminant were large, it could mask the proviral DNA which was actually integrated. However, further analysis of the nuclear Hirt pellet DNA with a restriction enzyme which distinguishes between integrated and unintegrated viral DNA indicated this possible artifact was not a major concern.

Figure 8 also indicated that wild-type M-MuLV-infected cells showed more viral DNA synthesized in all fractions as mentioned above. This was consistent with the higher specific infectivity of wild-type M-MuLV than the Mo+MMTV M-MuLVs, even in the presence of dexamethasone. It should be noted that equal amounts of virus particles, and not equal infectious units of the respective viruses, were used in the infections. Thus, it was expected that the DNA samples from the wild-type-infected cells would show higher levels of viral DNA than would cells infected with the Mo+MMTV M-MuLV DNAs.

DISCUSSION

In these experiments we report the generation of replication-competent M-MuLVs containing glucocorticoid response sequences from MMTV inserted into the M-MuLV LTR. Mo+MMTV M-MuLVs with MMTV sequences inserted in either orientation were hormonally responsive in that infection in the presence of dexamethasone was 3 logs more efficient than in the absence of hormone. Steady-state RNA measurements in infected cells as well as transient assays of LTR-CAT gene fusions both confirmed hormone responsiveness of the Mo+MMTV LTRs. However, the magnitude of induction observed was considerably less than the increase in infectivity (only two- to fourfold). Induction levels from 2- to 20-fold were seen by others when an MMTV LTR fragment was inserted in front of a heterologous gene (4, 15, 19, 22).

The generation of the Mo+MMTV M-MuLVs involved constructions of proviral organizations containing the altered LTRs. The first set of plasmids contained proviral organizations with MMTV sequences inserted only into the 3' LTR, which should have been sufficient in theory. However, RNA analysis indicated the appearance of M-MuLV lacking MMTV sequences, perhaps wild-type M-MuLV generated through DNA recombination during transfection. As a result, additional cloning steps were used to generate proviral DNA organizations containing MMTV sequences inserted into both 5' and 3' LTRs. The use of these clones in DNA transfections gave the desired results; Mo+MMTV M-MuLVs free of recombinant wild-type M-MuLV.

We previously reported the generation of M-MuLVs with LTRs containing altered U3 regions by using proviral organizations with only 3'-altered LTRs (20). In those experiments, recombinant wild-type M-MuLV lacking the altered LTRs were not detected. However, in the previous experiments, the altered LTRs were functionally as active as the wild-type M-MuLV LTR, and the resultant viruses were not severely reduced in growth potential. As a result, recombinant wild-type M-MuLV occurring at low frequency during transfection did not outgrow the altered M-MuLV. In contrast, the Mo+MMTV M-MuLVs described here were seriously reduced in infectivity, so that recombinant wild-type

M-MuLV could eventually predominate the infection. This may be a point of general applicability.

It has been proposed that the glucocorticoid response elements of MMTV function as hormone-responsive transcriptional enhancers, since they can confer hormone responsiveness to heterologous promoters in an orientation-independent fashion (4). Indeed, both Mo+MMTV⁺ and Mo+MMTV⁻ M-MuLVs were hormone responsive, which is consistent with this hypothesis. In addition, this hormone responsiveness could be conferred upon the M-MuLV promoter from various distances as determined by the LTR-CAT plasmid results. However, the insertion of MMTV sequences into the Δ Mo LTR (deleted of the M-MuLV enhancers) resulted in neither infectious virus nor detectable LTR promoter activity in the presence or absence of dexamethasone. Thus, the MMTV fragment used in these constructions could not functionally replace the M-MuLV enhancers in the M-MuLV LTR. The failure of substitution was not simply a technical problem, since we have previously generated infectious M-MuLV by the substitution of M-MuLV enhancers with enhancer sequences from polyomavirus (10) in the Δ Mo LTR.

A discrepancy was observed between the dramatic effect of dexamethasone on the infectivity of Mo+MMTV M-MuLVs versus the modest two- to fourfold induction in cytoplasmic M-MuLV-specific RNA. This led to more direct measurement of LTR promoter activities since it was possible that the cytoplasmic RNA measurements (steady-state levels) underestimated the increase in promoter activity after hormone treatment. This prompted the construction and assay of LTR-CAT plasmids. The CAT measurements indicated glucocorticoid induction of two- to fivefold for the Mo+MMTV LTRs, which was similar to the increase seen in cytoplasmic RNA measurements. Thus, the discrepancy was probably not due to an underestimate of the induction of Mo+MMTV LTR promoter activity.

One potential explanation for the relatively low hormone inducibility of the Mo+MMTV could have been the fact that only the 340-bp MMTV *Sau3A* fragment was inserted into the LTR, and the addition of other MMTV sequences may have increased the effect. However, a plasmid carrying the entire U3 region of the MMTV LTR (including all of the hormone response sequences and the promoter) fused to the bacterial CAT gene showed the same level of glucocorticoid induction (fourfold) as did the Mo+MMTV LTR-CAT plasmids (data not shown).

Another possible explanation for the discrepancy was that the inserted MMTV sequences might have conferred hormone responsiveness for viral DNA synthesis or integration upon the M-MuLV LTR. This would be plausible, since the LTR structure is critical for both of these events. However, direct measurements of viral DNA synthesis and integration for the Mo+MMTV M-MuLVs showed no change in the presence or absence of dexamethasone. Thus, the MMTV sequences may have conferred responsiveness at a step after DNA synthesis and integration. The discrepancy between infectivity and promoter responsiveness to dexamethasone is still under investigation.

The insertion of MMTV sequences into the wild-type M-MuLV LTR decreased LTR activity although at the same time conferring hormone responsiveness. The reduction was evident from the 5-fold decrease in virus production from infected cells as well as a 10-fold reduction in promoter activity in the LTR-CAT assays. One explanation could be that the lowered activity simply resulted from the insertion of 335 bp of DNA into the LTR. However, we have inserted

other DNA fragments of similar size into the *Xba*I site of the M-MuLV LTR without observing a decrease in promoter activity (unpublished data). In addition, two LTR-CAT plasmids containing MMTV sequences inserted outside of the M-MuLV LTR (pG1CAT and pG2CAT; Fig. 6) also showed a reduction in basal activity as well as hormone responsiveness. These results suggest that the MMTV regulatory sequences exerted a negative effect on the M-MuLV LTR in the LTR-CAT constructions described here. However, in work reported by others (4), the same MMTV fragment used in these experiments did not reduce the level of promoter activity when linked to the herpesvirus thymidine kinase gene. In addition, induction by the MMTV regulatory sequences has been associated with the positive binding of glucocorticoid receptor molecules. Thus, the basis of the apparent negative regulatory effect observed here is unclear. Also, an orientation effect on this reduction in activity was observed. When the MMTV fragment was placed into the *Xba*I site or the *Cla*I site in the LTR-CAT plasmids, the plasmids containing the MMTV orientation in the positive orientation consistently showed a greater reduction in activity as compared with the plasmids containing the MMTV fragment in the negative orientation. The significance of this observation is not known.

The pathogenicity of the Mo+MMTV M-MuLVs is of considerable interest. Both of the parental viruses cause slowly occurring neoplasms in mice: M-MuLV causes thymic lymphomas (24, 25), and MMTV causes mammary adenocarcinomas (13, 26). Recent results indicate that site-specific integration is an important step for carcinogenesis by both viruses: integrations into the *int-1* and *int-2* loci have been correlated with MMTV tumors (27, 29); integration into the *pim-1*, *pim-2* (6, 41), and *c-myc* (38) loci have been correlated with M-MuLV tumors. Site-specific integration and transcriptional activation of adjacent cellular sequences in retroviral tumors is generally related to the LTRs. Thus, it will be interesting to see what disease if any the chimeric LTRs of the Mo+MMTV M-MuLVs dictate. These viruses have been inoculated into neonatal NIH Swiss mice, but no disease has been observed yet after 4 months.

ACKNOWLEDGMENTS

We thank Euphemia Chao and Hilary Chute for their excellent technical assistance.

This work was supported by grants CA32454 and CA32455 from the National Cancer Institute.

LITERATURE CITED

- Bacheler, L., and H. Fan. 1981. Isolation of recombinant DNA clones carrying complete integrated proviruses of Moloney murine leukemia virus. *J. Virol.* 37:181-190.
- Berns, A. J. M., M. H. T. Lai, R. A. Bosselman, M. A. McKennett, L. T. Bacheler, H. Fan, E. C. Robanus Maandag, H. v. d. Putten, and I. M. Verma. 1980. Molecular cloning of unintegrated and a portion of integrated Moloney murine leukemia viral DNA in bacteriophage lambda. *J. Virol.* 36:254-263.
- Birnboim, H. C., and J. Doly. 1979. A rapid alkaline extraction procedure for screening recombinant plasmid DNA. *Nucleic Acids Res.* 7:1513-1523.
- Chandler, V. L., B. A. Maler, and K. R. Yamamoto. 1983. DNA sequences bound specifically by glucocorticoid receptor in vitro render a promoter responsive in vivo. *Cell* 33:489-499.
- Cooper, G. M., and S. Okenquist. 1978. Mechanism of transfection of chicken embryo fibroblasts by Rous sarcoma virus DNA. *J. Virol.* 28:45-52.
- Cuyppers, H. T., G. Selten, W. Quint, M. Zijlstra, E. R. Maandag, W. Boelens, P. van Wezenbeek, C. Melief, and A. Berns. 1984. Murine leukemia virus-induced T-cell lymphomagenesis: integration of proviruses in a distinct chromosomal region. *Cell* 37:141-150.
- Donehower, L. A., A. L. Huang, and G. L. Hagar. 1981. Regulatory and coding potential of the mouse mammary tumor virus long terminal redundancy. *J. Virol.* 37:226-238.
- Fan, H., H. Chute, E. Chao, and M. Feuerman. 1983. Construction and characterization of Moloney murine leukemia virus mutants unable to synthesize glycosylated gag polyprotein. *Proc. Natl. Acad. Sci. U.S.A.* 80:5965-5969.
- Fan, H., R. Jaenisch, and P. MacIsaac. 1978. Low-multiplicity infection of Moloney murine leukemia virus in mouse cells: effect on number of viral DNA copies and virus production in producer cells. *J. Virol.* 28:802-809.
- Gorman, C. M., L. F. Moffat, and B. H. Howard. 1982. Recombinant genomes which express chloramphenicol acetyltransferase in mammalian cells. *Mol. Cell. Biol.* 2:1044-1051.
- Graham, F. L., and A. J. van der Eb. 1973. A new technique for the assay of infectivity of human adenovirus 5 DNA. *Virology* 52:456-467.
- Grunstein, M., and J. Wallis. 1979. Colony hybridization. *Methods Enzymol.* 68:379-389.
- Hilgers, J., and P. Bentvelzen. 1978. Interaction between viral and genetic factors in murine mammary cancer. *Adv. Cancer Res.* 26:143-195.
- Hirt, B. 1967. Selective extraction of polyoma DNA from infected mouse cell cultures. *J. Mol. Biol.* 26:365-369.
- Hynes, N., A. J. J. Ooyen, N. Kennedy, P. Herrlich, H. Ponta, and B. Groner. 1983. Subfragments of the large terminal repeat cause glucocorticoid-responsive expression of mouse mammary tumor virus and of an adjacent gene. *Proc. Natl. Acad. Sci. U.S.A.* 80:3637-3641.
- Jolly, D. J., A. C. Esty, S. Subramani, T. Friedmann, and I. M. Verma. 1983. Elements in the long terminal repeat of murine retroviruses enhance stable transformation by thymidine kinase gene. *Nucleic Acids Res.* 11:1855-1877.
- Jones, N., and T. Shenk. 1979. Isolation of adenovirus type 5 host range deletion mutants defective for transformation of rat embryo cells. *Cell* 17:683-689.
- Laimins, L. A., G. Khoury, C. Gorman, B. Howard, and P. Gruss. 1982. Host-specific activation of transcription by tandem repeats from simian virus 40 and Moloney murine sarcoma virus. *Proc. Natl. Acad. Sci. U.S.A.* 79:6453-6457.
- Lee, F., R. Mulligan, P. Berg, and G. Ringold. 1981. Glucocorticoids regulate expression of dihydrofolate reductase cDNA in mouse mammary tumour virus chimaeric plasmids. *Nature (London)* 294:228-232.
- Linney, E., B. Davis, J. Overhauser, E. Chao, and H. Fan. 1984. Non-function of a Moloney murine leukaemia virus regulatory sequence in F9 embryonal carcinoma cells. *Nature (London)* 308:470-472.
- Linney, E., and S. Donerly. 1983. DNA Fragments from F9 PyEC mutants increase expression of heterologous genes in transfected F9 cells. *Cell* 35:693-699.
- Majors, J., and H. E. Varmus. 1983. A small region of the mouse mammary tumor virus long terminal repeat confers glucocorticoid hormone regulation on a linked heterologous gene. *Proc. Natl. Acad. Sci. U.S.A.* 80:5866-5870.
- Maniatis, T., E. F. Fritsch, and J. Sambrook. 1982. Molecular cloning. A laboratory manual. Cold Spring Harbor Laboratory, Cold Spring Harbor, N.Y.
- Moloney, J. B. 1960. Biological studies on a lymphoid-leukemia virus extracted from sarcoma 37. I. Origin and introductory investigations. *J. Natl. Cancer Inst.* 24:933-951.
- Moloney, J. B. 1960. Properties of a leukemia virus. *Natl. Cancer Inst. Monogr.* 4:7-38.
- Nandi, S., and C. M. McGrath. 1973. Mammary neoplasia in mice. *Adv. Cancer Res.* 17:353-414.
- Nusse, R., and H. E. Varmus. 1982. Many tumors induced by the mouse mammary tumor virus contain a provirus integrated in the same region of the host genome. *Cell* 31:99-109.
- Payvar, F., D. DeFranco, G. L. Firestone, B. Edgar, O. Wrange, S. Okret, J.-A. Gustafsson, and K. R. Yamamoto. 1983. Sequence-specific binding of glucocorticoid receptor to MTV

- DNA at sites within and upstream of the transcribed region. *Cell* **35**:381-392.
29. **Peters, G., S. Brookes, R. Smith, and C. Dickson.** 1983. Tumorigenesis by mouse mammary tumor virus: evidence for a common region for provirus integration in mammary tumors. *Cell* **33**:369-377.
 30. **Pfahl, M., D. McGinnis, M. Hendricks, B. Groner, and N. E. Hynes.** 1983. Correlation of glucocorticoid receptor binding sites on MMTV proviral DNA with hormone inducible transcription. *Science* **222**:1341-1343.
 31. **Rigby, P. W. J., M. Dieckman, C. Rhodes, and P. Berg.** 1977. Labeling deoxyribonucleic acid to high specific activity in vitro by nick translation with DNA polymerase I. *J. Mol. Biol.* **113**:237-251.
 32. **Ringold, G., E. Y. Lasfargues, M. J. Bishop, and H. E. Varmus.** 1975. Production of mouse mammary tumor virus by cultured cells in the absence or presence of hormones: assay by molecular hybridization. *Virology* **65**:135-147.
 33. **Ringold, G. M., K. R. Yamamoto, J. M. Bishop, and H. E. Varmus.** 1977. Glucocorticoid-stimulated accumulation of mouse mammary tumor virus RNA: increased rate of synthesis of viral RNA. *Proc. Natl. Acad. Sci. U.S.A.* **74**:2879-2883.
 34. **Ringold, G. M., K. R. Yamamoto, G. M. Tomkins, J. M. Bishop, and H. E. Varmus.** 1975. Dexamethasone-mediated induction of mouse mammary tumor virus RNA: a system for studying glucocorticoid action. *Cell* **6**:299-305.
 35. **Rowe, W. P., W. E. Pugh, and J. W. Hartley.** 1970. Plaque assay techniques for murine leukemia viruses. *Virology* **42**:1136-1139.
 36. **Scheidereit, C., S. Geisse, H. M. Westphal, and M. Beato.** 1983. The glucocorticoid receptor binds to defined nucleotide sequences near the promoter of mouse mammary tumor virus. *Nature (London)* **304**:749-752.
 37. **Southern, E. M.** 1975. Detection of specific sequences among DNA fragments separated by gel electrophoresis. *J. Mol. Biol.* **38**:503-517.
 38. **Steffen, D.** 1984. Proviruses are adjacent to c-myc in some murine leukemia virus-induced lymphomas. *Proc. Natl. Acad. Sci. U.S.A.* **81**:2097-2101.
 39. **Thomas, P. S.** 1980. Hybridization of denatured RNA and small DNA fragments transferred to nitrocellulose. *Proc. Natl. Acad. Sci. U.S.A.* **77**:5201-5205.
 40. **Todaro, G. J., and H. Green.** 1963. Quantitative studies of the growth of mouse embryo cells in culture and their development into established lines. *J. Cell. Biol.* **17**:299-313.
 41. **Tsichlis, P. N., P. G. Strauss, and C. A. Kozak.** 1984. Cellular DNA region involved in induction of thymic lymphomas (*Mlvi-2*) maps to mouse chromosome 15. *Mol. Cell. Biol.* **4**:997-1000.
 42. **Van Beveren, C., E. Rands, S. K. Chattopadhyay, D. R. Lowy, and I. M. Verma.** 1982. Long terminal repeat of murine retroviral DNAs: sequence analysis, host-proviral junctions, and preintegration site. *J. Virol.* **41**:542-556.