

First Countrywide Survey of Acquired Metallo- β -Lactamases in Gram-Negative Pathogens in Italy[∇]

Gian Maria Rossolini,^{1*} Francesco Luzzaro,² Roberta Migliavacca,³ Claudia Mugnaioli,¹ Beatrice Pini,² Filomena De Luca,¹ Mariagrazia Perilli,⁴ Simona Pollini,¹ Melissa Spalla,⁵ Gianfranco Amicosante,⁴ Antonio Toniolo,² and Laura Pagani³

Dipartimento di Biologia Molecolare, Laboratorio di Fisiologia e Biotecnologie dei Microrganismi, Università di Siena, I-53100 Siena,¹ Laboratorio di Microbiologia Ospedale di Circolo, Università dell'Insubria, I-21100 Varese,² Dipartimento di Scienze Morfologiche, Eidologiche e Cliniche, Sezione di Microbiologia, Università di Pavia, I-27100 Pavia,³ Dipartimento di Scienze e Tecnologie Biomediche, Università di L'Aquila, I-67100 L'Aquila,⁴ and Servizio Analisi Microbiologiche, Fondazione I.R.C.C.S. S. Matteo, I-27100 Pavia,⁵ Italy

Received 29 May 2008/Returned for modification 3 July 2008/Accepted 10 September 2008

Metallo- β -lactamases (MBLs) can confer resistance to most β -lactams, including carbapenems. Their emergence in gram-negative pathogens is a matter of major concern. Italy was the first European country to report the presence of acquired MBLs in gram-negative pathogens and is one of the countries where MBL producers have been detected repeatedly. Here, we present the results of the first Italian nationwide survey of acquired MBLs in gram-negative pathogens. Of 14,812 consecutive nonreplicate clinical isolates (12,245 *Enterobacteriaceae* isolates and 2,567 gram-negative nonfermenters) screened for reduced carbapenem susceptibility during a 4-month period (September to December 2004), 30 isolates (28 *Pseudomonas aeruginosa* isolates, 1 *Pseudomonas putida* isolate, and 1 *Enterobacter cloacae* isolate) carried acquired MBL determinants. MBL producers were detected in 10 of 12 cities, with a predominance of VIM-type enzymes over IMP-type enzymes (4:1). Although having an overall low prevalence (1.3%) and significant geographical differences, MBL-producing *P. aeruginosa* strains appeared to be widespread in Italy, with a notable diversity of clones, enzymes, and integrons carrying MBL gene cassettes.

β -Lactamase production is the major mechanism of resistance to β -lactam antibiotics in gram-negative pathogens. Carbapenemases, including the metallo- β -lactamases (MBLs) and the class A and class D serine carbapenemases, are emerging β -lactamases of major importance due to their ability to confer resistance to carbapenems in major gram-negative pathogens (27).

The acquired MBLs, in particular, are resistance determinants of remarkable clinical concern due to their very broad substrate spectra (including expanded-spectrum cephalosporins and carbapenems) and nonsusceptibility to therapeutic serine- β -lactamase inhibitors (5, 27, 30). Acquired MBL genes are usually clustered with other resistance determinants on mobile DNA elements, and their presence is a virtually constant marker for multidrug resistance (27, 30). The first identified acquired MBL, the IMP-1 enzyme, was discovered in the late 1980s in Japan, in multidrug-resistant (MDR) isolates of *Pseudomonas aeruginosa* (39). Thenceforth, enzymes of the IMP type or of five additional types of acquired MBLs (VIM, SPM, GIM, SIM, and AIM) have been detected worldwide in clinical isolates of gram-negative nonfermenters (GNNFs) showing complex MDR phenotypes and sometimes causing large nosocomial disease outbreaks (27, 30, 40). The IMP- and VIM-type MBLs are currently the most widespread and have also been detected in several enterobacterial species (30).

Although the number of reports on acquired MBLs has steadily increased during the past decade, most reports deal only with sporadic isolates or small outbreaks in individual institutions, while data from larger-scale epidemiological surveys are considerably more limited (5). Italy was the first European country (and the second country after Japan) to report the emergence of acquired MBLs (7, 20), as well as one of the countries where MBL-producing strains have repeatedly been detected (6, 8, 21–23, 33, 36) and even caused relatively large outbreaks of infection (18, 25).

In this work, we report the results of the first Italian nationwide survey of acquired MBLs among GNNFs and *Enterobacteriaceae*.

MATERIALS AND METHODS

Study design. Fourteen clinical microbiology laboratories from 12 Italian cities located across the national territory participated in the study (Fig. 1). In each laboratory, from September to December 2004, all consecutive nonreplicate isolates of *Enterobacteriaceae* and GNNFs were screened for reduced susceptibility to imipenem. Since the impact of MBL production on carbapenem susceptibility in different species can be variable and no specific guidelines on carbapenem MIC breakpoints for the screening of MBL producers are available (5), we adopted the following imipenem MIC breakpoints to indicate MBL production (based on data in the literature and on personal experience): *P. aeruginosa*, *Proteus* spp., *Morganella morganii*, and *Providencia* spp., >4 $\mu\text{g/ml}$; *Acinetobacter* spp. and other GNNFs other than *P. aeruginosa*, >2 $\mu\text{g/ml}$; and *Enterobacteriaceae* other than *Proteus* spp., *M. morganii*, and *Providencia* spp., >1 $\mu\text{g/ml}$. All isolates fitting these criteria were collected and subjected to confirmatory imipenem MIC testing. If an imipenem MIC higher than the screening breakpoint was confirmed, the isolate was subjected to a phenotypic analysis of MBL production and to the molecular characterization of MBL determinants. Confirmed MBL-producing isolates were further investigated for susceptibility to anti-gram-negative pathogen agents, genotypic relatedness, and the integron

* Corresponding author. Mailing address: Dipartimento di Biologia Molecolare, Sezione di Microbiologia, Università di Siena, Policlinico Santa Maria alle Scotte, I-53100 Siena, Italy. Phone: 39-0577-233455. Fax: 39-0577-233870. E-mail: rossolini@unisi.it.

[∇] Published ahead of print on 22 September 2008.

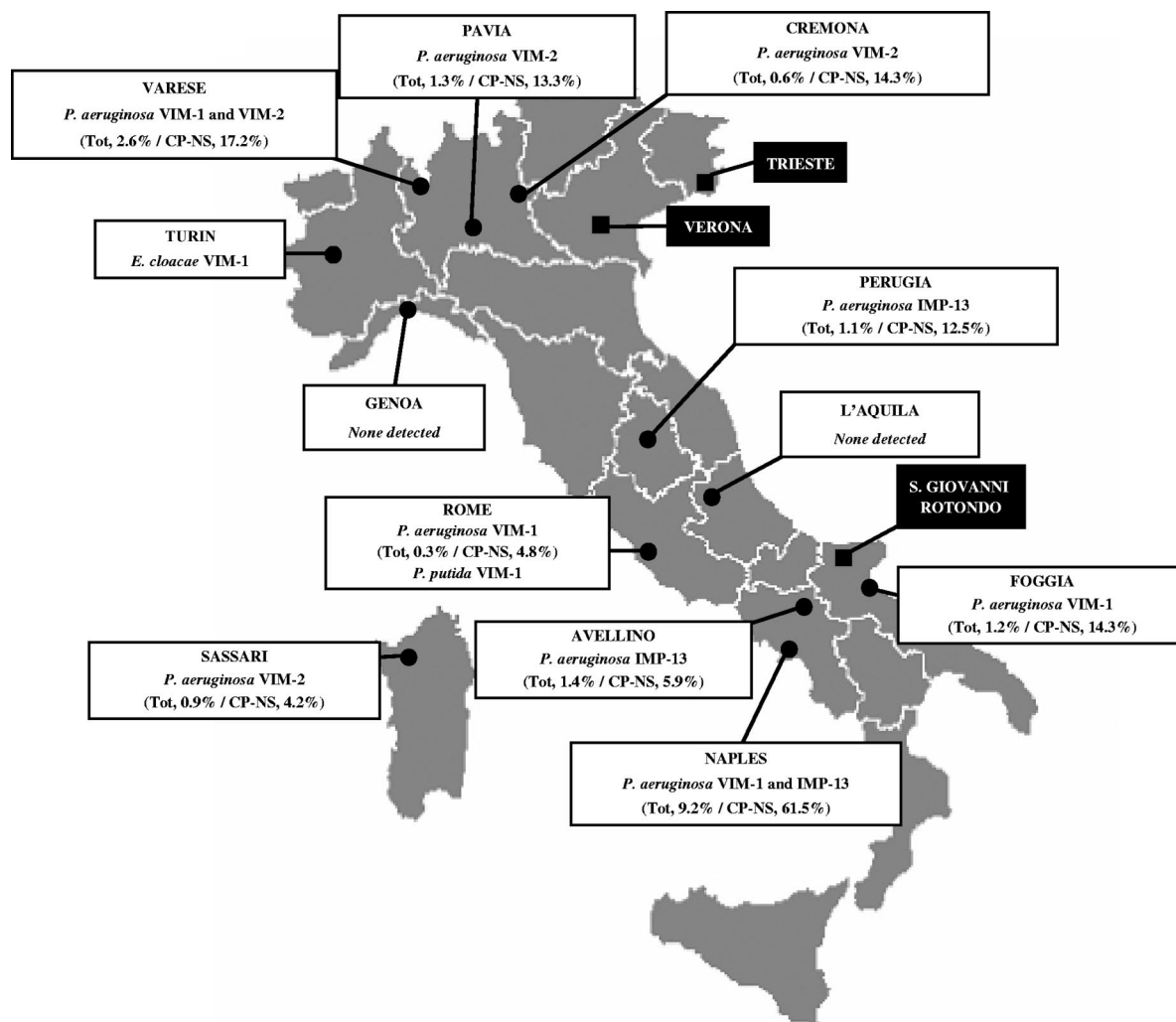

FIG. 1. Locations of the clinical microbiology laboratories participating in the survey (3 laboratories, whose data were pooled, were in Turin, while the remaining 11 were in the other cities) and distribution of the MBL-producing isolates. For each city, the MBL-producing species and enzyme types are indicated. For *P. aeruginosa*, the percentages of MBL producers among the total number of isolates (tot) and the total number of carbapenem-nonsusceptible isolates (CP-NS) are also shown in parentheses. The locations of Verona, where the VIM-1-producing *P. aeruginosa* index strain VR-143/97 was first detected (20), and Trieste and San Giovanni Rotondo, where two major outbreaks of infection with MBL-producing *P. aeruginosa* have been reported previously (18, 25), are also shown.

context of the MBL determinant. Due to their intrinsic resistance to carbapenems mediated by resident MBL production, isolates of *Stenotrophomonas maltophilia*, *Elizabethkingia meningoseptica*, and *Chryseobacterium indologenes* were not considered eligible for inclusion in the study.

Bacterial identification and antibiotic susceptibility testing. In all laboratories collecting isolates, identification to the species level and antimicrobial susceptibility testing were carried out with the Phoenix automated microbiology system (Becton Dickinson Diagnostic Systems, Sparks, MD). Confirmatory imipenem MIC testing of collected isolates and susceptibility testing of MBL producers were carried out by Etest (AB Biodisk, Solna, Sweden). Results of susceptibility testing were interpreted as recommended by the CLSI (4).

Phenotypic analysis of MBL production. Reference spectrophotometric assays for the detection of MBL activity were carried out as described previously (20). Positivity was demonstrated when an imipenem-hydrolyzing specific activity of ≥ 5 nmol/min/mg of protein was detectable in crude cell extracts and the activity was inhibited by at least 80% after the incubation of the extracts for 20 min in the presence of 5 mM EDTA at 20°C. All GNNF isolates were also tested for MBL production with the MBL Etest (AB Biodisk) using Mueller-Hinton agar plates (Oxoid) as recommended by the manufacturer (AB Biodisk). All *P. aeruginosa* isolates were also tested for MBL production with the EPI microdilution test as described previously (24). The test measures imipenem MICs in the presence or

absence of a mixture of EDTA plus 1,10-phenanthroline. Isolates are considered positive for MBL production when the imipenem MICs are decreased by at least fourfold in the presence of the chelator mixture (24). *P. aeruginosa* ATCC 27853 and *P. aeruginosa* 32SM (an imipenem-resistant clinical isolate from our collection that lacks OprD and constitutively produces the AmpC enzyme but does not produce any MBL enzyme) were used as negative controls. *P. aeruginosa* 101/1477 (producing IMP-1) (19) and *P. aeruginosa* VR-143/97 (producing VIM-1) (20) were used as positive controls.

Molecular analysis of MBL determinants and integrons. The presence of *bla*_{IMP}-like and *bla*_{VIM}-like MBL genes was investigated by a colony blot assay using random-primed ³²P-labeled DNA probes as described previously (23). Probes consisted of mixtures (1:1 molar ratio) of PCR-generated amplicons containing either the *bla*_{VIM-1} and *bla*_{VIM-2} or the *bla*_{IMP-2} and *bla*_{IMP-12} genes for the detection of *bla*_{VIM} or *bla*_{IMP} alleles, respectively. The nature of MBL genes was preliminarily determined by the direct sequencing of PCR amplification products obtained using primers VIM-DIA/f (5'-CAGATTGCCGATGGT GTTTGG) and VIM-DIA/r (5'-AGGTGGGCCATTCAGCCAGA) or IMP-DIA/f (5'-GGAATAGAGTGGCTTAATTCTC) and IMP-DIA/r (5'-GTGATG CGTCYCCAAYTTCACT), designed based on conserved regions of *bla*_{VIM} and *bla*_{IMP} genes as described previously (8). Nucleotide sequences of complete MBL genes were determined from both strands of PCR products generated with

TABLE 1. MBL production in nonreplicate clinical isolates of gram-negative isolates included in the survey

Species of isolate surveyed (n = 14,812)	No. (%) of isolates collected ^a	Range of imipenem MICs ($\mu\text{g/ml}$) ^b	No. of collected isolates positive for MBL production by:		
			MBL production reference assay ^c	MBL Etest ^d	EPI test ^e
<i>Enterobacteriaceae</i>					
<i>P. mirabilis</i> (n = 990)	9 (0.9)	8	0	NA	NA
<i>E. cloacae</i> (n = 614)	2 (0.3)	4–8	1	NA	NA
<i>E. aerogenes</i> (n = 248)	1 (0.4)	16	0	NA	NA
<i>K. pneumoniae</i> (n = 1,214)	1 (0.1)	2	0	NA	NA
Other species (n = 9,179)	0	NA ^f	NA	NA	NA
Total (n = 12,245)	13 (0.1)	NA	1	NA	NA
<i>GNNFs</i>					
<i>P. aeruginosa</i> (n = 2,103)	222 (10.6)	8–>256	28	29 ^g	28 ^h
<i>P. putida</i> (n = 60)	2 (3.3)	16–32	1	1 ⁱ	NA
<i>A. baumannii</i> (n = 237)	21 (8.9)	4–64	0	4	NA
<i>B. cepacia</i> complex (n = 50)	2 (4.0)	8–32	0	0	NA
Other species (n = 117)	0	NA	NA	NA	NA
Total (n = 2,567)	247 (9.6)	NA	29	34	NA

^a Isolates were collected from among the surveyed isolates on the basis of imipenem MICs higher than the tentative breakpoints set for the various species.

^b Imipenem MICs for the collected isolates.

^c In positive isolates, imipenem-hydrolyzing activity in crude extracts was ≥ 40 nmol/min/mg of protein.

^d Carried out on the collected GNNFs.

^e Carried out on the collected *P. aeruginosa* isolates.

^f NA, not applicable.

^g Including 27 isolates positive in the reference assay.

^h Corresponding to the 28 isolates positive in the reference assay.

ⁱ Corresponding to the isolate positive in the reference assay.

primers corresponding to regions outside the coding sequences. The structures of the variable regions of class 1 integrons containing MBL gene cassettes were determined by a PCR mapping and sequencing strategy as described previously (32).

Analysis of genomic relatedness of *P. aeruginosa* isolates. *P. aeruginosa* isolates producing MBLs were investigated for genomic relatedness by macrorestriction profiling of genomic DNA after the digestion of DNA with SpeI and fragment separation by pulsed-field gel electrophoresis as described previously (11). Scanned gel pictures were interpreted using the Fingerprinting II version 3.0 software (Bio-Rad Laboratories, Segrate, Italy) and the Dice coefficient analysis. The unweighted-pair group method with arithmetic averages was applied, and the bandwidth tolerance was set at 1.2%. Clonal relatedness was inferred as recommended by Tenover et al. (35). *P. aeruginosa* VR-143/97 (20), *P. aeruginosa* TS-832347 (17), and *P. aeruginosa* AV65 (25) were included for comparison as representatives of MBL-producing *P. aeruginosa* clones involved in previously reported disease outbreaks in Italy.

Nucleotide sequence accession numbers. The nucleotide sequences of the variable regions of In75, In88, and In89, determined in this work, have been submitted to the GenBank/EMBL database and assigned accession numbers FJ172675 (In75), FJ172674 (In88), and FJ172676 (In89).

RESULTS

Prevalence and sources of MBL-producing gram-negative bacteria. During the study period (September to December 2004), a total of 14,812 nonreplicate isolates of eligible gram-negative bacteria (12,245 *Enterobacteriaceae* isolates and 2,567 GNNFs) were handled by the participating laboratories. Overall, imipenem MICs for 13 of 12,245 enterobacteria (0.1%) and 247 of 2,567 GNNFs (9.6%) were higher than the screening breakpoints indicating MBL production. The 13 enterobacterial isolates included 9 *Proteus mirabilis* and 2 *Enterobacter cloacae* isolates, 1 *Enterobacter aerogenes* isolate, and 1 *Klebsiella pneumoniae* isolate. The 247 GNNFs included 222 *P.*

aeruginosa, 21 *Acinetobacter baumannii*, 2 *Burkholderia cepacia*, and 2 *Pseudomonas putida* isolates (Table 1).

The reference spectrophotometric assay detected the production of MBL activity in 30 (11.5%) of the 260 isolates collected, including 28 *P. aeruginosa* isolates, 1 *P. putida* isolate, and 1 *E. cloacae* isolate. The production of EDTA-resistant carbapenemase activity was never detected. The MBL Etest was positive for 29 *P. aeruginosa* isolates (including 27 of those positive in the spectrophotometric assay), 4 *A. baumannii* isolates, and 1 *P. putida* isolate (corresponding to that found to be positive in the spectrophotometric assay). The EPI test was positive for the 28 *P. aeruginosa* isolates determined to be positive by the spectrophotometric assay (Table 1).

MBL-producing isolates were detected in 10 of the 12 cities. MBL-producing *P. aeruginosa* isolates were detected in nine cities, with remarkably variable prevalences (either overall or among carbapenem-resistant isolates) (Fig. 1).

Isolates carrying MBL determinants were most frequently obtained from urine (47%). The remainder of these isolates were obtained from blood samples (17%), lower respiratory tract specimens (13%), pus samples (10%), surgical wound specimens (10%), and vascular catheter specimens (3%). Most patients (47%) providing the samples were hospitalized in intensive care units (Table 2).

Nature and distribution of the acquired MBL determinants. Colony blot hybridization confirmed the presence of known MBL determinants in each of the 30 isolates positive in the spectrophotometric assay, while no *bla*_{IMP} or *bla*_{VIM} genes were detected in any of the remaining 230 isolates.

The sequencing of the MBL determinants revealed the pres-

TABLE 2. Epidemiological data, MBL determinants, clonal lineages, and resistance phenotypes for the MBL₂-producing isolates

Isolate ^a	Specimen	Ward ^b	Enzyme	Clone	Integron ^b	MIC ^c (μg/ml) of:												
						PIP	TZP	CAZ	FEP	ATM	IMP	MEM	COL	AMK	GEN	CIP	LEV	
TO-16X-51	Urine	ICU	VIM-1	NA ^d	NA	>128	>128	>128	128	8	4	2	0.25	24	2	>32	>32	>32
RM-11X-11	Urine	ICU	VIM-1	NA	NA	>128	>128	>128	>128	8	>32	>32	0.25	1	>32	>32	0.25	
FG-17X-14	Sputum	ICU	VIM-1	A ₁	In70 ^e	>128	>128	>128	>128	6	>32	>32	1	8	>32	>32	>32	
NA-14X-21	Urine	ICU	VIM-1	A ₂	In70	>128	>128	>128	>128	8	>32	>32	2	24	>32	>32	>32	
NA-14X-26	Urine	ICU	VIM-1	A ₂	NA	>128	>128	>128	>128	8	>32	>32	2	32	>32	>32	>32	
NA-14X-32	Urine	ICU	VIM-1	A ₂	NA	>128	>128	>128	>128	6	>32	>32	2	24	>32	>32	>32	
NA-14X-34	Urine	ICU	VIM-1	A ₃	In70	>128	>128	>128	>128	6	>32	>32	2	24	>32	>32	>32	
FG-17X-08	Sputum	ICU	VIM-1	A ₃	NA	>128	>128	>128	>128	64	>32	>32	0.5	16	>32	>32	>32	
VA-06X-69	Urine	Nephrology	VIM-1	D	In110 ^f	>128	>128	>128	>128	4	>32	>32	1	8	>32	>32	>32	
VA-06X-63	Blood	Nephrology	VIM-1	D ₁	NA	>128	>128	>128	>128	4	>32	>32	1	8	>32	>32	>32	
VA-06X-16	Wound	Geriatrics	VIM-1	D ₂	In110	>128	>128	>128	>128	4	>32	>32	1	8	>32	>32	>32	
VA-06X-17	specimen Wound	Pneumology	VIM-1	D ₂	In110	>128	>128	>128	>128	6	>32	>32	1	8	>32	>32	>32	
VA-06X-65	specimen Sputum	Pneumology	VIM-1	D ₃	In110	>128	>128	>128	>128	0.25	>32	>32	0.5	8	>32	>32	>32	
VA-06X-47	Urine	Nephrology	VIM-1	D ₄	In110	>128	>128	>128	>128	4	>32	>32	1	8	>32	>32	>32	
VA-06X-29	Pus	Otology	VIM-1	E	In80 ^g	>128	>128	>128	>128	8	>32	>32	2	>128	>32	>32	>32	
RM-11X-09	Wound	ICU	VIM-1	F	In75 ^h	>128	>128	>128	>128	16	>32	>32	1	8	>32	>32	>32	
NA-14X-13	specimen Blood	ICU	VIM-1	G	In105 ^e	>128	>128	>128	>128	8	>32	>32	2	128	>32	>32	>32	
SS-09X-45	Urine	Nephrology	VIM-2	B ₁	NA ^g	>128	>128	>128	>128	6	>32	>32	2	128	>32	>32	>32	
VA-06X-20	Urine	Orthopedics	VIM-2	B ₂	NA	64	64	64	64	8	>32	>32	1	>128	>32	>32	>32	
VA-06X-28	Blood	Geriatrics	VIM-2	B ₂	NA	64	64	64	64	8	>32	>32	1	>128	>32	>32	>32	
VA-06X-38	Wound	Geriatrics	VIM-2	B ₂	In59 ^g	32	48	48	48	4	>32	>32	1	>128	>32	>32	>32	
CR-04X-14	specimen Blood	ICU	VIM-2	B ₃	NA	>128	>128	>128	>128	8	>32	>32	2	>128	>32	>32	>32	
PV-05X-02	Wound	Medicine	VIM-2	B ₃	In59	48	32	32	32	8	>32	8	1	>128	>32	>32	>32	
PV-05X-07	specimen Vascular catheter	Pneumology	VIM-2	B ₃	NA	48	32	32	48	8	>32	8	1	>128	>32	>32	>32	
AV-13X-28	specimen Urine	ICU	IMP-13	C ₁	In88 ^g	24	16	>128	>128	8	16	8	2	8	>32	>32	>32	
NA-14X-02	Urine	Urology	IMP-13	C ₂	In89 ^g	24	16	>128	>128	16	>32	>32	0.5	16	>32	>32	>32	
NA-14X-10	Blood	ICU	IMP-13	C ₂	NA	16	16	>128	>128	16	>32	>32	0.5	16	>32	>32	>32	
NA-14X-11	Urine	Urology	IMP-13	C ₂	NA	16	16	>128	>128	16	>32	>32	0.5	16	>32	>32	>32	
NA-14X-12	Urine	Urology	IMP-13	C ₂	NA	16	16	>128	>128	16	>32	>32	0.5	16	>32	>32	>32	
PG-12X-03	Sputum	ICU	IMP-13	C ₃	InPSG ^g	16	16	>128	>128	16	>32	>32	0.5	>128	>32	>32	>32	

^a The first two letters of the name indicate the city of origin (Fig. 1), as follows: TO, Turin; RM, Rome; FG, Foggia; NA, Naples; VA, Varese; SS, Sassari; CR, Cremona; PV, Pavia; AV, Avellino; and PG, Perugia. The first two isolates listed, TO-16X-51 and RM-11X-11, were *E. cloacae* and *P. putida*, respectively; all other isolates listed were *P. aeruginosa*.

^b The structures of the variable regions of class 1 integrons carrying MBL gene cassettes in *P. aeruginosa* isolates representative of different clonal lineages and variants thereof were determined.

^c Abbreviations for antimicrobial agents: PIP, piperacillin; TZP, piperacillin-tazobactam; CAZ, ceftazidime; FEP, ceftipime; ATM, aztreonam; IMP, imipenem; MEM, meropenem; COL, colistin; AMK, amikacin; GEN, gentamicin; CIP, ciprofloxacin; and LEV, levofloxacin.

^d NA, not applicable.

^e Integron detected previously in Italy or France (11, 12, 21, 25, 28, 31).

^f New integron detected in this work.

^g Amplification of the *bla*_{VIM-2}-containing integron was unsuccessful with this isolate.

^h Ward in which the patient providing the sample was hospitalized. ICU, intensive care unit.

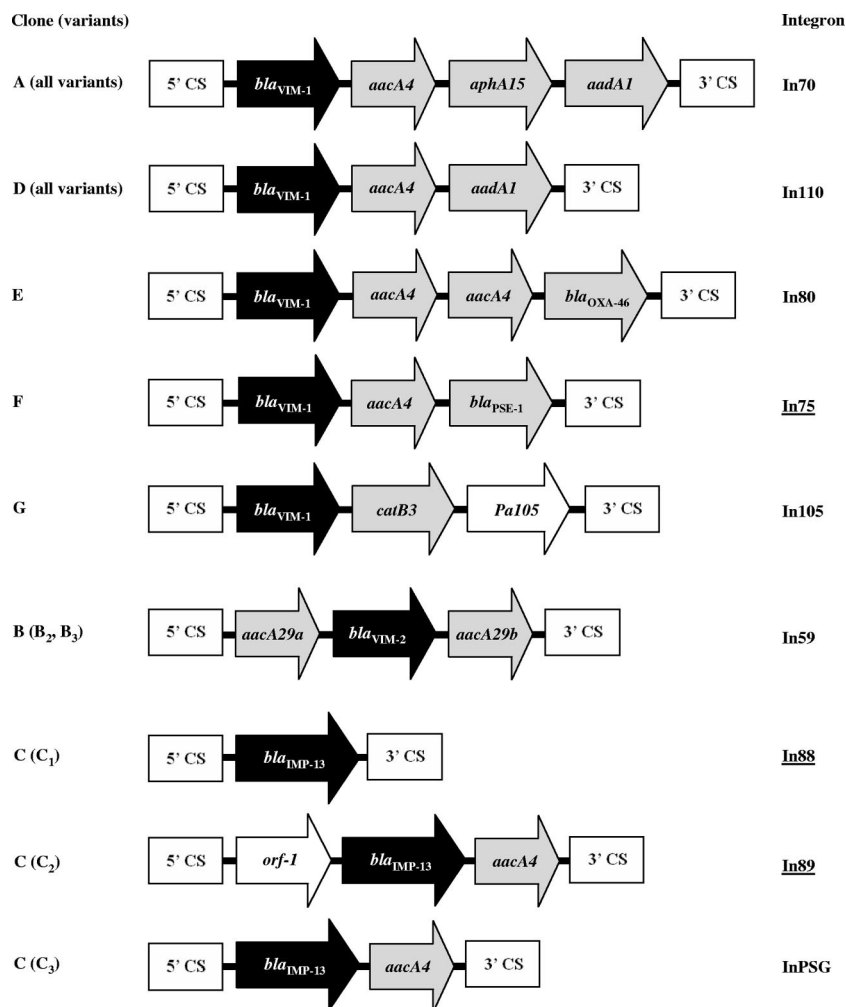

FIG. 2. Structures of the variable regions of class 1 integrons carrying MBL gene cassettes in different clones and variants of MBL-producing *P. aeruginosa*. The gene cassettes are indicated by arrows (those representing cassettes carrying MBL genes are black; those representing cassettes carrying other known resistance genes are gray). 5' conserved segments (5' CS) and 3' conserved segments (3' CS) flanking the cassette arrays are also indicated. Underlined integrons are those first detected in this study.

ence of *bla*_{IMP-13} in 6 *P. aeruginosa* isolates from three centers, that of *bla*_{VIM-2} in 7 *P. aeruginosa* isolates from four centers, and that of *bla*_{VIM-1} in 15 *P. aeruginosa* isolates from four centers, as well as in the single *P. putida* and *E. cloacae* isolates (Fig. 1; Table 2).

Clonal diversity of MBL-producing *P. aeruginosa* isolates.

The clonal diversity of the 28 MBL-producing *P. aeruginosa* isolates was investigated by pulsed-field gel electrophoresis macrorestriction profiling after the digestion of DNA with SpeI. Overall, clonal relatedness among isolates producing different MBL types or variants was not apparent (Table 2).

The VIM-1-producing isolates appeared to belong in five clonal lineages, of which one (clone A) included six isolates from two different cities, while the others included isolates detected in single centers (Table 2). Interestingly, the isolates of clone A were clonally related to the serotype O11 ST227 VIM-1-producing index strain originally detected in Verona and subsequently involved in a large disease outbreak occurring in Trieste (11, 17, 20) (data not shown).

All isolates producing VIM-2 appeared to be related to one

another (clone B), and they were also clonally related to the VIM-2-producing *P. aeruginosa* strain involved in the outbreak in Trieste (17) (data not shown).

Finally, all isolates producing IMP-13 appeared to be related to one another (clone C), and they were also clonally related to the IMP-13-producing *P. aeruginosa* strain previously involved in a large nosocomial disease outbreak that occurred in San Giovanni Rotondo (25) (data not shown).

Integron context of the MBL-encoding gene cassettes. The structures of the variable regions of class 1 integrons carrying the *bla*_{VIM} or *bla*_{IMP} gene cassettes in several *P. aeruginosa* isolates representative of different clonal lineages and variants were determined.

Different integron structures were found in different clones and also in different variants of the IMP-13-producing clone. On the other hand, a conserved integron structure was shared by variants of each VIM-1-producing clone and by variants of the VIM-2-producing clone (Table 2; Fig. 2).

Several of these integrons (In59, In70, In80, In110, In105, and InPSG) have already been identified in MBL-producing

isolates from Italy or France and have been described previously (11, 12, 21, 25, 28, 31), while the structures of three of them were original (Fig. 2).

Susceptibility of MBL-positive isolates to clinically relevant drugs. MBL-positive *P. aeruginosa* isolates were always characterized by an MDR phenotype including resistance to carbapenems, cephalosporins, fluoroquinolones, and gentamicin. Some remained susceptible to amikacin (50%), aztreonam (75%), and piperacillin-tazobactam (39%), while all were susceptible to colistin. In contrast, the MBL-producing *P. putida* isolate showed a resistance phenotype limited to β -lactams (except aztreonam), whereas aminoglycosides and fluoroquinolones retained activity against this strain. Finally, the VIM-1-producing *E. cloacae* isolate showed high-level resistance to penicillins, cephalosporins, and fluoroquinolones, while it showed intermediate susceptibility to amikacin and was susceptible to aztreonam and gentamicin. Carbapenem MICs for this isolate also remained in the range indicating susceptibility, although they were close to the breakpoint (Table 2).

DISCUSSION

The emergence of acquired MBLs among gram-negative pathogens including GNNFs and enterobacteria is an increasing problem worldwide (27, 30). However, the epidemiology of these resistance determinants remains largely unknown (5). This study reports the results of the first countrywide survey of the prevalence of acquired MBLs among gram-negative pathogens in Italy, one of the first countries where the problem has been detected (7, 20). Results revealed the widespread presence of these resistance determinants in *P. aeruginosa*, while they appeared to be very uncommon in enterobacteria and virtually absent in *Acinetobacter* spp. The overall MBL prevalence in *P. aeruginosa* was relatively low (1.3%), being similar to those reported in earlier large-scale surveys in Japan (1.3 to 1.9%) (15, 16) but somewhat higher than that reported previously in Greece (0.8%) (10) and much higher than that reported in a contemporary survey from Spain (0.1%) (13). Although in most cities, the prevalence was close to the average national value, in a single center (Naples), it was approximately eightfold higher (Fig. 1). Similar high prevalences of MBL producers in the Calgary Health Region of Canada (26) and also in the University Hospital of Thessaly in Greece (29) have recently been reported, suggesting that in some settings the epidemiological impact of MBLs can be consistently greater than that reported in general.

Concerning the very low prevalence of acquired MBLs in *Enterobacteriaceae* observed in this survey, it seems very unlikely to have resulted from a low sensitivity of the criteria adopted for screening. In fact, the screening breakpoints were overall consistent with the most recent recommendations issued by the CLSI in order to suspect carbapenemase production in *Enterobacteriaceae* (4).

Molecular analysis revealed three types of MBL genes circulating in Italy, namely, *bla*_{VIM-1}, *bla*_{VIM-2}, and *bla*_{IMP-13}. These correspond to the ones most frequently reported in Italy (1, 3, 6, 20, 22, 33) and also those reported to be involved in large outbreaks (17, 25). *bla*_{VIM}-type determinants were overall more prevalent and widespread than *bla*_{IMP}-type ones. For

MBL-producing *P. aeruginosa*, a notable diversity was also observed at the clonal and integron levels, suggesting that both clonal expansion and horizontal gene transfer phenomena are playing a role in the dissemination of MBL-producing *P. aeruginosa* in our setting. The multiclonal diffusion of the VIM-1 MBL determinant in *P. aeruginosa* and the presence of this determinant in other species also may reflect an overall higher propensity of the VIM-1 MBL determinant for horizontal spread.

The MBL Etest, which is broadly used for the screening of MBL producers, was able to correctly categorize most MBL-producing *P. aeruginosa* isolates and the single MBL-producing *P. putida* isolate. However, it yielded false-positive results for two *P. aeruginosa* and four *A. baumannii* isolates. It also yielded two false-negative results, those for two IMP-13-producing *P. aeruginosa* isolates, as reported previously (25).

In conclusion, despite an overall low prevalence of acquired MBLs, MBL production was found to be a widespread resistance mechanism in *P. aeruginosa* strains circulating in Italy, involving multiple clones and enzyme types. Although at the time of the survey, acquired MBLs were found to be exceedingly uncommon in *Enterobacteriaceae*, they have recently shown a remarkable dissemination in different enterobacterial species and *Acinetobacter* in Greece (9, 37, 38), and outbreaks of infection with MBL-producing strains of *K. pneumoniae* and other *Enterobacteriaceae* have also started to be reported in Spain (34), France (2, 14), and Italy (1, 3). Altogether, these findings underscore that resistance mediated by MBL production can rapidly evolve and may become a major problem in the near future, and they emphasize the need for the continuous surveillance of these emerging resistance determinants.

ACKNOWLEDGMENTS

The excellent contribution of many colleagues is gratefully acknowledged: L. Andrini (Ospedale Mauriziano, Turin); G. Bruno (Ospedale di L'Aquila, L'Aquila); P. Buonopane (A. O. San Giuseppe Moscati, Avellino); M. Casini Lemmi (Ospedale Galliera, Genoa); G. Cherchi (Ospedale Santissima Annunziata, Sassari); A. Di Taranto (Ospedali Riuniti, Foggia); L. Ferrari (Ospedale di Cremona, Cremona); G. Fucile (Centro Traumatologico Ortopedico, Turin); E. Giacobone (IRCCS San Matteo, Pavia); A. Lavitola (Università Federico II, Naples); A. Mencacci (Università di Perugia, Perugia); B. Pini (Ospedale di Circolo, Varese); M. Tronci, (Ospedale San Camillo, Rome); and G. Viberti (Ospedale San Luigi Gonzaga, Orbassano).

This work was partially supported by a research grant from Becton Dickinson Europe and by a grant from the FP6 European research framework (LSHM-CT2005-018705) to G.M.R.

REFERENCES

- Aschbacher, R., M. Doumith, D. M. Livermore, C. Larcher, and N. Woodford. 2008. Linkage of acquired quinolone resistance (*qnrS1*) and metallo- β -lactamase (*bla*_{VIM-1}) genes in multiple species of *Enterobacteriaceae* from Bolzano, Italy. *J. Antimicrob. Chemother.* **61**:515–523.
- Biendo, M., B. Canarelli, D. Thomas, F. Rousseau, F. Hamdad, C. Adjide, G. Laurans, and F. Eb. 2008. Successive emergence of extended-spectrum β -lactamase-producing and carbapenemase-producing *Enterobacter aerogenes* isolates in a university hospital. *J. Clin. Microbiol.* **46**:1037–1044.
- Cagnacci, S., L. Gualco, S. Roveta, S. Mannelli, L. Borgianni, J. D. Docquier, F. Dodi, M. Centanaro, E. Debbia, A. Marchese, and G. M. Rossolini. 2008. Bloodstream infections caused by multidrug-resistant *Klebsiella pneumoniae* producing the carbapenem-hydrolyzing VIM-1 metallo- β -lactamase: first Italian outbreak. *J. Antimicrob. Chemother.* **61**:296–300.
- Clinical and Laboratory Standards Institute. 2008. Performance standards for antimicrobial susceptibility testing: 18th informational supplement. Clinical and Laboratory Standards Institute, Wayne, PA.
- Cornaglia, G., M. Akova, G. Amicosante, R. Canton, R. Cauda, J. D. Docquier, M. Edelstein, J. M. Frere, M. Fuzi, M. Galleni, H. Giamarellou, M.

- Gniadkowski, R. Koncan, B. Libisch, F. Luzzaro, V. Miriagou, F. Navarro, P. Nordmann, L. Pagani, L. Peixe, L. Poirel, M. Souli, E. Tacconelli, A. Vatoopoulos, and G. M. Rossolini. 2007. Metallo- β -lactamases as emerging resistance determinants in Gram-negative pathogens: open issues. *Int. J. Antimicrob. Agents* **29**:380–388.
6. Cornaglia, G., A. Mazzariol, L. Lauretti, G. M. Rossolini, and R. Fontana. 2000. Hospital outbreak of carbapenem-resistant *Pseudomonas aeruginosa* producing VIM-1, a novel transferable metallo- β -lactamase. *Clin. Infect. Dis.* **31**:1119–1125.
 7. Cornaglia, G., M. L. Riccio, A. Mazzariol, L. Lauretti, R. Fontana, and G. M. Rossolini. 1999. Appearance of IMP-1 metallo- β -lactamase in Europe. *Lancet* **353**:899–900.
 8. Docquier, J. D., M. L. Riccio, C. Mugnaioli, F. Luzzaro, A. Endimiani, A. Toniolo, G. Amicosante, and G. M. Rossolini. 2003. IMP-12, a new plasmid-encoded metallo- β -lactamase from a *Pseudomonas putida* clinical isolate. *Antimicrob. Agents Chemother.* **47**:1522–1528.
 9. Galani, L., M. Souli, E. Koratzanis, G. Koratzanis, Z. Chrysouli, and H. Giamarellou. 2007. Emerging bacterial pathogens: *Escherichia coli*, *Enterobacter aerogenes* and *Proteus mirabilis* clinical isolates harbouring the same transferable plasmid coding for metallo- β -lactamase VIM-1 in Greece. *J. Antimicrob. Chemother.* **59**:578–579.
 10. Giakkoupi, P., G. Petrikos, L. S. Tzouveleki, S. Tsonas, N. J. Legakis, and A. C. Vatoopoulos. 2003. Spread of integron-associated VIM-type metallo- β -lactamase genes among imipenem-nonsusceptible *Pseudomonas aeruginosa* strains in Greek hospitals. *J. Clin. Microbiol.* **41**:822–825.
 11. Giske, C. G., B. Libisch, C. Colinson, E. Scoulica, L. Pagani, M. Fuzi, G. Kronvall, and G. M. Rossolini. 2006. Establishing clonal relationships between VIM-1-like metallo- β -lactamase-producing *Pseudomonas aeruginosa* strains from four European countries by multilocus sequence typing. *J. Clin. Microbiol.* **44**:4309–4315.
 12. Giuliani, F., J. D. Docquier, M. L. Riccio, L. Pagani, and G. M. Rossolini. 2005. OXA-46, a new class D β -lactamase of narrow substrate specificity encoded by a bla_{VIM-1} -containing integron from a *Pseudomonas aeruginosa* clinical isolate. *Antimicrob. Agents Chemother.* **49**:1973–1980.
 13. Gutierrez, O., C. Juan, E. Cercenado, F. Navarro, E. Bouza, P. Coll, J. L. Perez, and A. Oliver. 2007. Molecular epidemiology and mechanisms of carbapenem resistance in *Pseudomonas aeruginosa* isolates from Spanish hospitals. *Antimicrob. Agents Chemother.* **51**:4329–4335.
 14. Kassir-Chikhani, N., D. Decre, V. Gautier, B. Burghoffer, F. Saliba, D. Mathieu, D. Samuel, D. Castaing, J. C. Petit, E. Dussaix, and G. Arlet. 2006. First outbreak of multidrug-resistant *Klebsiella pneumoniae* carrying bla_{VIM-1} and bla_{SHV-5} in a French university hospital. *J. Antimicrob. Chemother.* **57**:142–145.
 15. Kimura, S., J. Alba, K. Shiroto, R. Sano, Y. Niki, S. Maesaki, K. Akizawa, M. Kaku, Y. Watanuki, Y. Ishii, and K. Yamaguchi. 2005. Clonal diversity of metallo- β -lactamase-possessing *Pseudomonas aeruginosa* in geographically diverse regions of Japan. *J. Clin. Microbiol.* **43**:458–461.
 16. Kurokawa, H., T. Yagi, N. Shibata, K. Shibayama, and Y. Arakawa. 1999. Worldwide proliferation of carbapenem-resistant gram-negative bacteria. *Lancet* **354**:955.
 17. Lagatolla, C., E. Edalucci, L. Dolzani, M. L. Riccio, F. De Luca, E. Medessi, G. M. Rossolini, and E. A. Tonin. 2006. Molecular evolution of metallo- β -lactamase-producing *Pseudomonas aeruginosa* in a nosocomial setting of high-level endemicity. *J. Clin. Microbiol.* **44**:2348–2353.
 18. Lagatolla, C., E. A. Tonin, C. Monti-Bragadin, L. Dolzani, F. Gombac, C. Bearzi, E. Edalucci, F. Gionchetti, and G. M. Rossolini. 2004. Endemic carbapenem-resistant *Pseudomonas aeruginosa* with acquired metallo- β -lactamase determinants in European hospital. *Emerg. Infect. Dis.* **10**:535–538.
 19. Laraki, N., M. Galleni, I. Thamm, M. L. Riccio, G. Amicosante, J. M. Frere, and G. M. Rossolini. 1999. Structure of In31, a bla_{IMP} -containing *Pseudomonas aeruginosa* integron phylogenically related to In5, which carries an unusual array of gene cassettes. *Antimicrob. Agents Chemother.* **43**:890–901.
 20. Lauretti, L., M. L. Riccio, A. Mazzariol, G. Cornaglia, G. Amicosante, R. Fontana, and G. M. Rossolini. 1999. Cloning and characterization of bla_{VIM} , a new integron-borne metallo- β -lactamase gene from a *Pseudomonas aeruginosa* clinical isolate. *Antimicrob. Agents Chemother.* **43**:1584–1590.
 21. Lombardi, G., F. Luzzaro, J. D. Docquier, M. L. Riccio, M. Perilli, A. Coli, G. Amicosante, G. M. Rossolini, and A. Toniolo. 2002. Nosocomial infections caused by multidrug-resistant isolates of *Pseudomonas putida* producing VIM-1 metallo- β -lactamase. *J. Clin. Microbiol.* **40**:4051–4055.
 22. Luzzaro, F., J. D. Docquier, C. Colinson, A. Endimiani, G. Lombardi, G. Amicosante, G. M. Rossolini, and A. Toniolo. 2004. Emergence in *Klebsiella pneumoniae* and *Enterobacter cloacae* clinical isolates of the VIM-4 metallo- β -lactamase encoded by a conjugative plasmid. *Antimicrob. Agents Chemother.* **48**:648–650.
 23. Luzzaro, F., A. Endimiani, J. D. Docquier, C. Mugnaioli, M. Bonsignori, G. Amicosante, G. M. Rossolini, and A. Toniolo. 2004. Prevalence and characterization of metallo- β -lactamases in clinical isolates of *Pseudomonas aeruginosa*. *Diagn. Microbiol. Infect. Dis.* **48**:131–135.
 24. Migliavacca, R., J. D. Docquier, C. Mugnaioli, G. Amicosante, R. Daturi, K. Lee, G. M. Rossolini, and L. Pagani. 2002. Simple microdilution test for detection of metallo- β -lactamase production in *Pseudomonas aeruginosa*. *J. Clin. Microbiol.* **40**:4388–4390.
 25. Pagani, L., C. Colinson, R. Migliavacca, M. Labonia, J. D. Docquier, E. Nucleo, M. Spalla, B. M. Li, and G. M. Rossolini. 2005. Nosocomial outbreak caused by multidrug-resistant *Pseudomonas aeruginosa* producing IMP-13 metallo- β -lactamase. *J. Clin. Microbiol.* **43**:3824–3828.
 26. Pitout, J. D., B. L. Chow, D. B. Gregson, K. B. Laupland, S. Elsayed, and D. L. Church. 2007. Molecular epidemiology of metallo- β -lactamase-producing *Pseudomonas aeruginosa* in the Calgary Health Region: emergence of VIM-2-producing isolates. *J. Clin. Microbiol.* **45**:294–298.
 27. Poirel, L., J. D. Pitout, and P. Nordmann. 2007. Carbapenemases: molecular diversity and clinical consequences. *Future Microbiol.* **2**:501–512.
 28. Poirel, L., T. Lambert, S. Turkoglu, E. Ronco, J. Gaillard, and P. Nordmann. 2001. Characterization of class 1 integrons from *Pseudomonas aeruginosa* that contain the bla_{VIM-2} carbapenem-hydrolyzing β -lactamase gene and of two novel aminoglycoside resistance gene cassettes. *Antimicrob. Agents Chemother.* **45**:546–552.
 29. Pournaras, S., M. Maniati, E. Petinaki, L. S. Tzouveleki, A. Tsakris, N. J. Legakis, and A. N. Maniatis. 2003. Hospital outbreak of multiple clones of *Pseudomonas aeruginosa* carrying the unrelated metallo- β -lactamase gene variants bla_{VIM-2} and bla_{VIM-4} . *J. Antimicrob. Chemother.* **51**:1409–1414.
 30. Queenan, A. M., and K. Bush. 2007. Carbapenemases: the versatile β -lactamases. *Clin. Microbiol. Rev.* **20**:440–458.
 31. Riccio, M. L., L. Pallecchi, R. Fontana, and G. M. Rossolini. 2001. In70 of plasmid pAX22, a bla_{VIM-1} -containing integron carrying a new aminoglycoside phosphotransferase gene cassette. *Antimicrob. Agents Chemother.* **45**:1249–1253.
 32. Riccio, M. L., N. Franceschini, L. Boschi, B. Caravelli, G. Cornaglia, R. Fontana, G. Amicosante, and G. M. Rossolini. 2000. Characterization of the metallo- β -lactamase determinant of *Acinetobacter baumannii* AC-54/97 reveals the existence of bla_{IMP} allelic variants carried by gene cassettes of different phylogeny. *Antimicrob. Agents Chemother.* **44**:1229–1235.
 33. Rossolini, G. M., M. L. Riccio, G. Cornaglia, L. Pagani, C. Lagatolla, L. Selan, and R. Fontana. 2000. Carbapenem-resistant *Pseudomonas aeruginosa* with acquired bla_{VIM} metallo- β -lactamase determinants, Italy. *Emerg. Infect. Dis.* **6**:312–313.
 34. Tato, M., T. M. Coque, P. Ruiz-Garbajosa, V. Pintado, J. Cobo, H. S. Sader, R. N. Jones, F. Baquero, and R. Canton. 2007. Complex clonal and plasmid epidemiology in the first outbreak of *Enterobacteriaceae* infection involving VIM-1 metallo- β -lactamase in Spain: toward endemicity? *Clin. Infect. Dis.* **45**:1171–1178.
 35. Tenover, F. C., R. D. Arbeit, R. V. Goering, P. A. Mickelsen, B. E. Murray, D. H. Persing, and B. Swaminathan. 1995. Interpreting chromosomal DNA restriction patterns produced by pulsed-field gel electrophoresis: criteria for bacterial strain typing. *J. Clin. Microbiol.* **33**:2233–2239.
 36. Toleman, M. A., D. Biedenbach, D. M. Bennett, R. N. Jones, and T. R. Walsh. 2005. Italian metallo- β -lactamases: a national problem? Report from the SENTRY Antimicrobial Surveillance Programme. *J. Antimicrob. Chemother.* **55**:61–70.
 37. Tsakris, A., A. Ikonomidis, S. Pournaras, L. S. Tzouveleki, D. Sofianou, N. J. Legakis, and A. N. Maniatis. 2006. VIM-1 metallo- β -lactamase in *Acinetobacter baumannii*. *Emerg. Infect. Dis.* **12**:981–983.
 38. Vatoopoulos, A. 24 January 2008, posting date. High rates of metallo- β -lactamase-producing *Klebsiella pneumoniae* in Greece—a review of the current evidence. *Euro Surveill.* **13**:pii=8023. <http://www.eurosurveillance.org/ViewArticle.aspx?ArticleId=8023>.
 39. Watanabe, M., S. Iyobe, M. Inoue, and S. Mitsuhashi. 1991. Transferable imipenem resistance in *Pseudomonas aeruginosa*. *Antimicrob. Agents Chemother.* **35**:147–151.
 40. Yong, D., J. M. Bell, B. Ritchie, R. Pratt, M. A. Toleman, and T. R. Walsh. 2007. A novel sub-group metallo- β -lactamase (MBL), AIM-1, emerges in *Pseudomonas aeruginosa* (PSA) from Australia. *Abstr. 47th Intersci. Conf. Antimicrob. Agents Chemother. abstr. C1-593*.