

Review

Psoriatic arthritis: from pathogenesis to therapyOliver FitzGerald¹ and Robert Winchester²¹Department of Rheumatology, St Vincent's University Hospital, Elm Park, Dublin, 4, Ireland²Department of Medicine, Division of Rheumatology, Columbia University, New York, NY 10032, USACorresponding author: Oliver FitzGerald, oliver.fitzgerald@ucd.ie

Published: 12 February 2009

This article is online at <http://arthritis-research.com/content/11/1/214>

© 2009 BioMed Central Ltd

Arthritis Research & Therapy 2009, **11**:214 (doi:10.1186/ar2580)**Abstract**

Psoriatic arthritis is a multigenic autoimmune disease that involves synovial tissue, enthesal sites and skin, and that may result in significant joint damage. Although there are no diagnostic tests for psoriatic arthritis, research has identified consistent features that help to distinguish the condition from other common rheumatic diseases. Comparison of HLA-B and HLA-C regions in psoriatic arthritis with those in psoriasis without joint involvement demonstrates significant differences, such that psoriatic arthritis cannot be viewed simply as a subset of genetically homogeneous psoriasis. T-cell receptor phenotypic studies have failed to identify antigen-driven clones, and an alternative hypothesis for CD8 stimulation involving innate immune signals is proposed. Finally, imaging studies have highlighted enthesal involvement in psoriatic arthritis, and it is possible that enthesal-derived antigens may trigger an immune response that is critically involved in disease pathogenesis.

Introduction

There has been considerable progress in advancing our understanding and treatment of psoriatic arthritis (PsA), but major challenges and paradoxes remain, and in some instances these have become more clearly defined. It is our objective to review, concisely and critically, some of these topics and provide an interpretive framework.

Evidence is increasing that PsA is an autoimmune disease in which the CD8⁺ T cell plays a central role. This review highlights evidence supporting the following: autoimmune features of the disease, including the genetic susceptibility associated with class I human leukocyte antigen (HLA) genes in the major histocompatibility complex (MHC); the finding of a predominance of clonally expanded CD8⁺ T cells in the synovial tissue and fluid [1]; the independence from participation of CD4⁺ T cells, as indicated by the development of PsA in the setting of advanced AIDS; the interesting observation of PsA developing for the first time after syngeneic bone marrow transplantation from a psoriasis donor

[2]; and the response to therapeutic agents directed at activated T cells (for example, DAB389IL-2 or alefacept), as well as to effector pathways resulting from T-cell activation. Autoantibodies are not detectable in PsA, distinguishing this and the other class I associated diseases, such as ankylosing spondylitis, from the autoimmune diseases associated with class II MHC alleles, in which autoantibodies presumably engendered through CD4⁺ T-cell help are conspicuous. As is the case with all autoimmune diseases, the nature of the peptide that drives the T-cell response remains unknown, and some of the reasons for the difficulty of this identification in PsA are mentioned.

In this review considerable stress is placed on important insights resulting from the application of newer imaging modalities. These modalities greatly expand the clinical spectrum in PsA, and they assist in advancing the conceptual framework of this disease and point to tissues and cell types that might express driving autoantigens.

Genetic susceptibility

Compared with most other rheumatic diseases, heredity plays a particularly strong role in the development of PsA. About 15% of the relatives of an index patient with PsA will also have PsA, and an additional 30% to 45% will have psoriasis. Accordingly, the presence of either psoriasis or PsA in a family member of a patient suspected of having PsA provides support for the diagnosis. Identification of the genes responsible for this high degree of familial aggregation remains an ongoing process but, among the identified genes, the HLA genes in the MHC are of primary importance in the development of PsA. The patterns of inheritance of psoriasis and PsA are those of a genetically complex multigenic disease, and may range from those that simulate a dominant mode of inheritance to families in which the illness appears to have a recessive mode (Figure 1).

DIP = distal interphalangeal; HLA = human leukocyte antigen; IL = interleukin; MHC = major histocompatibility complex; MRI = magnetic resonance imaging; NK = natural killer; OPG = osteoprotegerin; PsA = psoriatic arthritis; RA = rheumatoid arthritis; RANK = receptor activator of nuclear factor- κ B; TCR = T-cell receptor; TNF = tumour necrosis factor; US = ultrasound.

Figure 1

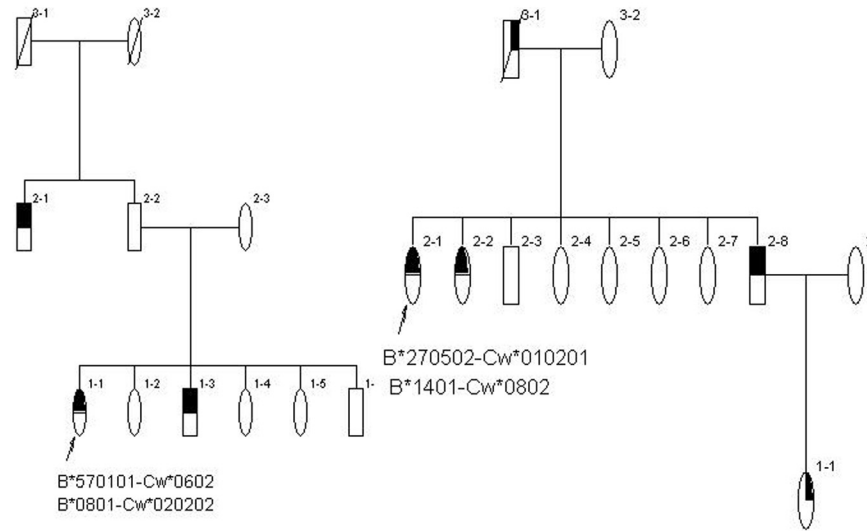

Inheritance of psoriatic arthritis. Two families are shown in which psoriatic arthritis (half-filled shapes) appears to exhibit a different pattern of inheritance. In the first it appears that the disease is inherited as a simple dominant, although the absence of disease in the parents is not consistent with this. In the second, there is an interplay between the psoriasis phenotype (quarter-filled shapes) in the parent and child in the third generation, and the instances of psoriatic arthritis in the second.

It is increasingly being recognized that the genetic features of PsA differ according to whether the case series is ascertained in a rheumatology clinic, reflecting presentation as a musculoskeletal disorder, or whether it is ascertained in a dermatology unit, where psoriasis patients with more severe skin disease are first identified and then a subset with musculoskeletal features is delineated after a decade or more of skin disease [3].

In contrast to most other autoimmune diseases in which susceptibility is specified by HLA-DR or other class II MHC genes, in PsA it is the class I genes, notably alleles at the HLA-B and HLA-C loci, that are involved. These include the HLA-C allele *Cw*0602*, which is the major determinant of susceptibility to psoriasis, and the HLA-B alleles *B*27* and *B*39*, and possibly some additional alleles [3,4]. Ho and coworkers [5], in a careful immunogenetic study, re-emphasized that *HLA-DRB1*04* alleles encoding the shared epitope, and strongly associated with susceptibility to rheumatoid arthritis (RA), were not associated with PsA. Furthermore, they showed that *HLA-Cw*06* and *HLA-DRB1*07* were indeed associated with patients with PsA having type I (onset before age 40 years) but not type II psoriasis (onset after age 40 years). This report shows that patients with PsA who have type I psoriasis have a genetic background different from those with type II psoriasis and in turn from RA.

Ongoing analyses indicate that these several MHC alleles operate independently in specifying the disease phenotype of PsA. This suggests that there could be two genetic pathways to PsA [3,4]. One is through the function of the HLA-B alleles

*B*27* and *B*39*, and another is through the function of haplotypes containing the HLA-C allele *Cw*0602* (*Psors1*). Evidence is emerging that these two forms of PsA that share the psoriasis phenotype are subtly different. It appears that the *Cw*0602* alleles confer a phenotype with more severe skin disease and, on average, a long interval (≥ 10 years) between the appearance of psoriasis and the development of the musculoskeletal features of PsA. In those with *B*27* or *B*39*, the musculoskeletal component appears more synchronously with the cutaneous component, and PsA is more likely than in the presence of *Cw*0602*. The complex relationship between these two different genetic substrates in terms of developing PsA is illustrated in Figure 2.

This emerging genetic information has the potential to be integrated into the challenge of validating the PsA diagnostic criteria. These genetic advances, if applied to series of cases, should also identify the misclassification as PsA of patients with psoriasis who simply also have fibromyalgia, osteoarthritis or a repetitive motion injury.

In view of the high degree of familial aggregation and the overall heritability of PsA, it is unlikely that the HLA genes account for more than a portion of the genetic susceptibility. There are likely to be non-MHC genes that specify important aspects of the development of PsA.

Immunopathogenesis

The presence of susceptibility genes in an individual defines the first preclinical stage of the development of PsA. The T-cell

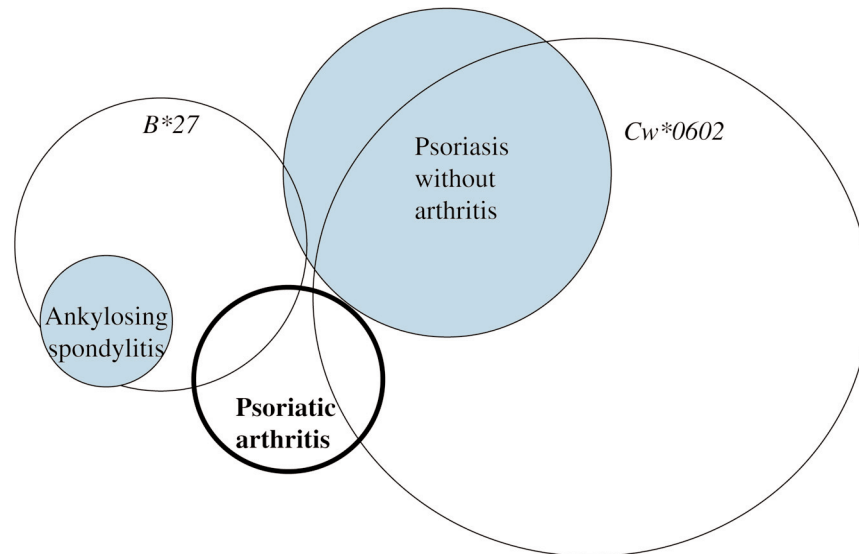
Figure 2

Representation of the complex relationship between HLA susceptibility and psoriatic arthritis. The areas on the diagram are not exactly drawn to scale. The right side of the diagram depicts the presence of the *Cw*0602* allele in healthy people, its strong association with cutaneous psoriasis susceptibility, and the fact that approximately 40% of those with psoriasis lack *Cw*0602*. The left side depicts the almost complete association of *B*27* with ankylosing spondylitis. Psoriatic arthritis, which includes psoriasis plus the musculoskeletal phenotype, is shown as the thick rimmed circle. Both *Cw*0602* and *B*27* alleles contribute independently to psoriatic arthritis susceptibility. HLA, human leukocyte antigen.

repertoire that is developed on the individual's self-peptides and self-MHC is poised for autoreactivity, but remains quiescent until triggered. Once triggered the immune process results in the development of the two main features of PsA: the inflammatory infiltrate of T cells and accessory cells into the entheses and synovium, and the response of the synovial and enthesal tissues to the products and consequences of the inflammatory infiltrate. These alterations are summarized in this section of the review.

Some insight into the immune and pathogenetic events that underlie PsA came from an unexpected source. During the early stages of the HIV pandemic the *de novo* appearance of PsA and of reactive arthritis in those with advanced loss of CD4⁺ T cells was an experiment of nature that distinguished these two spondyloarthritis disorders from most other rheumatic diseases such as RA and systemic lupus erythematosus, which were ameliorated by the loss of CD4⁺ T cells. This occurrence directed attention to the possibility that the pathogenesis of PsA differed substantively from that of RA and systemic lupus erythematosus. It emphasized that, in the pathogenesis of PsA, one had to consider the role of CD8⁺ T cells activated by the innate immune system, as well as elevated cytokines and triggering by persisting microbes.

Biology of MHC class I molecules and the roles they may play in PsA

The function of MHC molecules is to bind and present small soluble peptides to T cells. The T-cell receptor (TCR)

inspects the complex of peptide and MHC, and if the fit is sufficiently good this results in triggering of the TCR. The biological roles played by class I molecules, such as are encoded by *HLA-B* and *HLA-C* alleles involved in PsA susceptibility, differ greatly from those of class II molecules. Class I molecules function in the immunosurveillance for intracellular infection, typically by a virus, by presenting peptides derived from cytoplasmic proteins to the TCR of CD8⁺ lineage T cells. Usually, the presence of a virally infected cell results in it being killed by the CD8⁺ T cell.

Because the entire repertoire of T cells is selected in the thymus on self peptides presented by the various self MHC molecules of the person, the repertoire is latently self-reactive. One explanation for the association of the HLA alleles *B*27* and *B*39*, and *Cw*0602* with PsA susceptibility is that the molecules encoded by these alleles recognize self-peptides derived from proteins found in enthesal and synovial sites. T-cell clones specific for these self-peptides would be inappropriately activated, perhaps by dendritic cells, and the activated state perpetuated by the continual supply of self-peptides. This is the classic explanation of an autoimmune disease as a consequence of driver clones, and one would expect to recognize one or a few immunodominant TCR sequences in the inflammatory infiltrate. Another explanation that could be relevant to disease immunopathogenesis in the approximately 15% of PsA patients who have *HLA-B*27* is the nature of the *HLA-B*27* molecule itself, as initially suggested by the development of an arthrocutaneous

syndrome in rats transgenic for multiple copies of *HLA-B*27* [6]. However, the large majority of PsA patients lack *HLA-B*27*, and the development of PsA in association with other HLA alleles is not accounted for by this mechanism.

The question of whether the disease has the characteristics of a single peptide-driven T-cell response was addressed in detailed studies of the nature of the population of T cells found in the inflammatory joint fluid and in the synovium. Lymphocyte phenotypic subpopulations can be readily isolated from the joint fluid by fluorescence activated cell sorting techniques. By isolating the RNA from the lymphocyte subpopulations and determining the sequence of the T cell receptors, the composition of the T cell repertoire can thus be enumerated. The objective of these studies was to define the extent to which the synovial infiltrate consists of one or a few dominant expanded clones, suggesting antigen drive, or conversely a large number of unrelated T cells that are not clonally expanded.

The results of these analyses of the character of the infiltrating T cells in PsA joint fluids and tissues [7,8] revealed two features. The first is the presence of large expansions of CD8⁺ T-cell clones implicating the adaptive immune response in the disease. However, these expanded clones lacked obvious common structural motifs that would imply the presence of an antigen drive by one or a few peptide autoantigens. This implies that there is some set of specific events that triggers the adaptive immune response of clonal expansion, but that this trigger is broader than usually anticipated in the study of T-cell responses [9]. The finding of different T-cell clones in different joints and at different times is not consistent with a simple driver clone hypothesis, and it suggests that a more intricate explanation is likely to account for the puzzling combination of high expansion of a few clones but the presence of a succession of different dominant clones in time and space. The second feature was the additional presence of a background of nonclonally expanded polyclonal T cells, presumably reflecting the attraction of the T cells by chemokines. Only this latter polyclonal population is markedly reduced by methotrexate therapy [8].

Co-stimulation of CD8⁺ T-cell clones by stress-induced ligands

What could account for this clonal activation? Viruses use various strategies to prevent their identification by the MHC class I surveillance mechanism, and principal among these is inhibition of class I MHC expression, which results in lowering of surface class I MHC molecules on the surface of the infected cell. To cope with this ancient viral strategy, higher organisms have responded with the development of a lineage of lymphocytes, the natural killer (NK) cells, which are specialists in recognizing the absence of a normal amount of MHC class I ('missing self'). There are several kinds of NK receptors, found on NK cells and also on memory effector CD8⁺ T cells that are specialists in this recognition.

Additional NK receptors on memory effector CD8⁺ T cells, along with those that recognize missing self, respond to molecules induced by inflammatory cues or cellular stress. These molecules replace the co-stimulatory molecule CD28 expressed on naïve T cells. We hypothesize that an overbalance of stimulatory signals and triggering of the CD8⁺ T cells through NK receptor engagement is responsible for triggering these T-cell clones. Triggering of NK cells by killer immunoglobulin receptors, a subset of NK receptors, has been proposed to be a feature of PsA [10]. Similarly, triggering of memory effector cells produced in the response to pathogens by Toll-like receptor ligands induces their activation. Through this combination of innate immune signals, a T-cell clone with relatively low affinity for a target can be driven to respond to self-peptide.

Epidemiological studies support the potential role of infection and trauma in the period before the development of PsA in those with psoriasis [11]. Among 98 PsA patients and 163 control individuals, a number of environmental exposures occurred that were associated with the onset of arthritis in patients with psoriasis. These included rubella vaccination and injury sufficient to require a medical consultation [11]. We consider one hypothetical explanation for the events in the T-cell repertoire in PsA is that an array of T cells with TCRs that have low specificity for peptides expressed in the entheses or the synovium are differentiated to memory effector status and have their NK receptors engaged by these innate ligands. The ongoing inflammation and stress induced by infection or trauma compensate for the diminished TCR affinity for self-peptides and the clones are triggered to expand and continue to mediate synovial tissue injury.

Synovial tissue

The clinical criterion of tender and swollen joints reflecting underlying synovitis is not specific for PsA, and at the bedside it is often not distinguishable from the synovitis of RA. This has two consequences. The first of these is that in the clinic it may be difficult to determine the extent and nature of joint involvement - a difficulty that is being resolved by advances in imaging technology, as discussed below. Second, the important question to address is whether the synovial tissue in PsA exhibits any differentiating immunological features that would provide further insight into disease pathogenesis.

Synovial tissue in PsA is characterized by a sublining infiltrate with T cells and B cells, vascular proliferation and a relatively thin lining layer of proliferating intimal synoviocytes. Indeed, studies would suggest that the synovitis in PsA can be distinguished from RA, with quantitative differences in the features of the tissue, although there are no unique pathological hallmarks in either disease [12]. A recent study compared synovial immunohistological features in spondyloarthritis, including PsA, with those of RA [13]. Spondyloarthritis tissue exhibited greater vascularity ($P < 0.001$) and neutrophil

($P=0.010$) and CD163⁺ macrophage counts ($P<0.05$), whereas lining layer thickness and the number of CD83⁺ dendritic cells were greater in RA ($P<0.05$). In RA, 44% of samples exhibited positive staining for intracellular citrullinated proteins and 46% for MHC human cartilage gp39 peptide complexes, whereas no staining for these markers was observed in spondyloarthropathy samples (both $P=0.001$). The authors concluded that the synovial histopathology of PsA resembles that of other spondyloarthropathy subtypes and, like spondyloarthropathy, can be differentiated from RA on the basis of these synovial features, suggesting that peripheral synovitis in PsA belongs to the spondyloarthropathy concept. This difference is consistent with the genetic difference between RA and PsA emphasized in the studies conducted by Ho and coworkers [5]

Synovial tissue in PsA is also characterized by expression of pro-inflammatory cytokines, including IL-1, interferon- γ , tumour necrosis factor (TNF)- α , IL-6, IL-12, IL-15, IL-17 and IL-18 [14-16]. Lymphoid aggregates are described and, as in RA, occur in association with peripheral lymph node addressin-positive high endothelial venules and with the expression of the chemokines CXCL13 (C-X-C chemokine ligand 13) and CCL21 (C-C chemokine ligand 21) [17]. In keeping with the prominent vascular changes described both on arthroscopy and on immunohistology, promoters of angiogenesis are also upregulated, with expression of vascular endothelial growth factor, its receptors Flt-1 and KDR, and of angiopoietin-1 and -2 [18].

Finally, Ritchlin and colleagues [19] showed that PsA peripheral blood mononuclear cells readily formed osteoclasts *in vitro*. In further immunohistochemical analysis of subchondral bone and synovium, receptor activator of nuclear factor- κ B (RANK)-positive perivascular mononuclear cells and osteoclasts were seen. RANK ligand expression was dramatically upregulated in the synovial lining layer, whereas osteoprotegerin (OPG) immunostaining was restricted to the endothelium. Although bone erosions are not a striking feature in all patients with PsA, a model for understanding the pathogenesis of aggressive bone erosions in PsA was proposed in which osteoclasts, derived from TNF- α -activated peripheral blood mononuclear cells, migrate to the inflamed synovium and subchondral bone, where they are exposed to unopposed RANK ligand and TNF- α , leading to osteoclastogenesis at the erosion front. These findings have been confirmed by others [20]. However, the expression of RANK ligand and OPG was not different between patients with nonpsoriatic spondyloarthropathy, those with psoriatic spondyloarthropathy and those with RA; was not related to the degree of systemic or local inflammation; and was not significantly modulated by highly effective treatment with TNF- α blockers. Thus, differences in the synovial expression of RANK ligand, OPG and RANK cannot alone explain the radiological features observed in PsA.

Taken together, the above data confirm a histological pattern of joint inflammation similar to that in other spondyloarthropathies but sharing cytokine, chemokine and osteoclast promoting pathways found in chronic arthropathies. Despite extensive analysis, specific diagnostic features have not emerged though reproducible quantitative differences, in particular related to vascularity and perhaps to neutrophil infiltration, have been shown in several controlled studies. The presence of common cytokine pathways certainly explains the utility of several biologic therapies, such as TNF blockers, in a number of chronic arthropathies. Differential responses do occur, however, from which we may further clarify the relative importance of certain pathways. For example, targeting B cells in RA has proven efficacy, whereas several reports have suggested that PsA patients may not respond. Likewise, efalizumab - a humanized anti-CD11a monoclonal antibody - is licensed for treatment of psoriasis but appears to be ineffective in joint disease and may indeed trigger joint features [21].

The answer to the question 'What is PsA and how is it diagnosed?' remains of great importance. In the absence of complete knowledge of the pathogenic mechanism, a definitive laboratory test remains a distant goal. Accordingly, there has been a considerable emphasis on the development of syndromic criteria used for diagnosis and classification. The recently developed CASPAR (CIASsification criteria for Psoriatic ARthritis) criteria have largely been accepted by those working in the area [22]. It will be important to validate these criteria by determining whether they identify a genetically and pathogenetically distinctive group of individuals who may be expected to have a similar response to therapies.

Imaging

The detailed changes within the tissues and the underlying pathogenic mechanisms that they signify are not readily appreciated at the bedside, except in terms of their ultimate consequences of painful, tender swollen and stiff joints. However, imaging techniques, particularly those involving the newer modalities of magnetic resonance imaging (MRI) and ultrasound (US) provide a much more detailed characterization of the tissue abnormalities.

The classic radiological features of PsA include new bone formation at enthesal sites; bone resorption or osteolysis; sacroiliitis, which is often asymmetrical; and the hallmark pencil-in-cup type deformity, which results from a combination of new bone formation and osteolysis. These features sometimes have diagnostic utility but none are specific, and more often the radiological features in PsA are either minimal or nonspecific. For example, erosions do occur in PsA but less frequently than in RA, and the rate of development of new erosions is much slower. In one study of early PsA, 47% of patients had developed erosive disease at 2 years but the number of erosions only increased from a mean of 1.2 (\pm 2.9) to a mean of 3 (\pm 5.2) [23]. Although this increase was

significant ($P=0.002$), the number of new erosions is fewer than are described in RA [24]. In contrast, new bone formation is not a feature of RA.

Despite these differences from RA, clinical trials in PsA have used instruments developed for RA (usually the Sharp score or a modification thereof) when assessing radiological progression [25,26]. Taken together with the fact that joint involvement in PsA is frequently oligoarticular and asymmetrical, the use of such instruments to assess radiological progression of PsA may not be appropriate. A radiological scoring system developed for PsA that would reflect differences both in joint distribution and radiological features would be a welcome addition. Significant changes between active treatment and placebo have been demonstrated in clinical trials using these instruments borrowed from RA, affording some utility to their application to PsA, although the changes were less impressive than in RA.

Plain radiography certainly suggests that mechanisms of joint damage in PsA differ from those in RA, with the combination of new bone formation and erosions. Preliminary studies have examined whether these differences might be reflected in levels of soluble markers of bone turnover. In a study of 62 patients (27 PsA and 35 RA), bone alkaline phosphatase measurements, reflecting new bone formation, were significantly higher in PsA than in RA (mean T score: 1.42 versus 0.29; $P<0.05$) [27]. These preliminary results emphasize the importance of further studies aimed at improving our understanding of the mechanisms of joint damage in PsA.

The application of both US and MRI techniques to PsA has also improved our understanding of disease mechanisms. A recent study comparing US, MRI and plain radiography has shown that both US and MRI are more sensitive for visualization of inflammatory and destructive changes in fingers and toes of patients with PsA [28]. US has highlighted tendon and ligament involvement to an extent not appreciated clinically. In a comparative study, 56% of enthesal sites were abnormal on US as compared with 22% detected clinically [29]. Examination of dactylitic digits using US has demonstrated that both synovitis and tenosynovitis contribute to disease features [30].

The use of MRI in PsA has emphasized the importance of enthesitis with bone marrow oedema occurring at enthesal sites [31]. Indeed, as a result of these observations, it has been proposed that involvement of the enthesis is the primary event in PsA, with synovial involvement occurring in a non-specific manner [32]. Although this proposal has provoked debate and is controversial, it has helped to focus research on the enthesis and surrounding structures. It certainly could be that disease is triggered after perturbation of the enthesis and consequent exposure of enthesal-derived antigens to a genetically primed immune system.

Enthesal changes have also been demonstrated in distal interphalangeal (DIP) joints in PsA. Tan and coworkers [33] compared the MRI and histological findings of the DIP joint in 10 patients with PsA, 10 with osteoarthritis and 10 normal control individuals. In PsA, the dorsal capsular enthesis was the epicentre of an inflammatory reaction. This extended to involve the soft tissues adjacent to the nail in eight out of 10 PsA patients, but only in four of 10 cases with osteoarthritis and in none of the normal fingers. The DIP joint capsule was intimately linked with the nail complex on histology, with the dorsal, volar and lateral aspects of the nail bed being ensheathed in fibres extending from the entheses. This study suggests that the nail is as much an integral part of the enthesis organ as it is of the skin, which has implications for enhanced understanding of the disease. In a further study of 13 PsA dactylitic digits, synovitis and soft tissue oedema were the most frequent abnormalities, being present in 69% of tender dactylitic digits, but bone oedema and flexor tenosynovitis were also frequently seen [34].

Taken together, MRI studies in PsA have demonstrated considerable capsular, enthesal and bony changes in PsA that are quite different from those observed in RA [28]. These imaging studies should be useful clinically in supporting a diagnosis of PsA in an individual who presents only with synovitis and psoriasis, and ultimately in clinical trials as an index of response.

Current disease paradigm

The current paradigm of PsA places the lymphocyte, and in particular the CD8⁺ T cell, at the root of the pathogenic scheme. We accept this as a paradigm, and it is supported by many observations, but it should be kept in mind that this is not yet an established fact. The most likely implication of the HLA associations is that the susceptible person's T-cell repertoire contains CD8⁺ T cells that can recognize peptides derived from proteins in a still unknown triggering or target cell, which we will arbitrarily designate a fibrocartilage cell. These peptides are bound in the context of the MHC molecules that confer susceptibility, which are expressed on the surface of these triggering cells. The possible mechanisms that lead to activation of this cell have been discussed, but once activated the CD8⁺ T cells differentiate to memory effector phenotype and acquire the ability to injure target cells and release cytokines (for example, interferon- γ), reprogramming gene expression of nearby cells and, importantly, activating macrophages and vascular endothelium.

In considering the pathogenesis of PsA, the following findings - referred to above - must be considered.

- Although there are strong heritability factors, PsA is genetically not simply a subset of psoriasis. Additional HLA and probably other genes contribute to disease expression.
- Tissue involvement in PsA includes synovium and skin, but MRI and US studies have highlighted the involvement

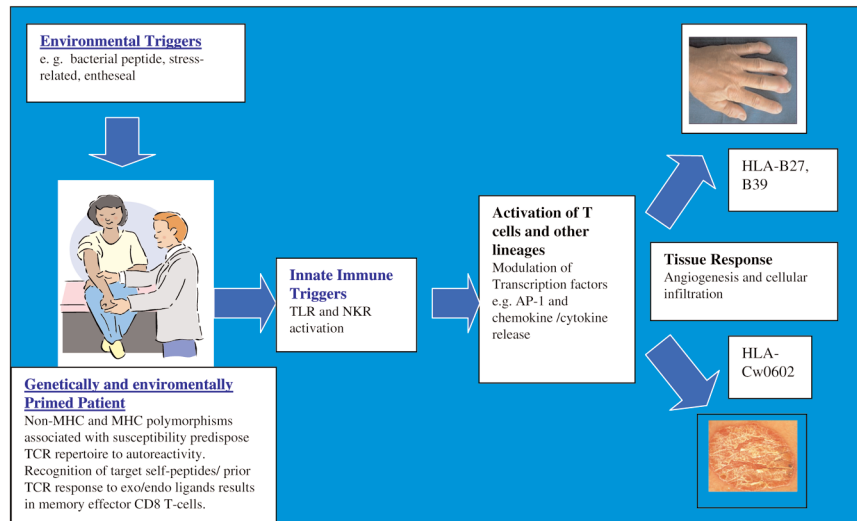
Figure 3

Immunopathogenesis of psoriatic arthritis. A proposed model for psoriatic arthritis immunopathogenesis is illustrated in which a genetically primed individual is exposed to a bacterial, stress, or enthesal-related peptide. This in turn activates the innate immune response, resulting in CD8 infiltration and chemokine/cytokine release. The process is amplified with angiogenesis and cellular infiltration of involved tissues. HLA and other genes expressed may determine the exact pattern of tissue involvement. HLA, human leukocyte antigen; MHC, major histocompatibility complex; NKR, natural killer cell receptor; TCR, T-cell receptor; TLR, Toll-like receptor.

of the enthesis as well as the joint capsule and tenosynovial tissues.

- Angiogenesis, endothelial activation and neutrophil infiltration are prominent features in PsA synovial tissue.
- In keeping with a class I HLA association, CD8⁺ T cells predominate in synovial fluid with clonal expansion identified. Antigen-driven T cells responses have proven difficult to demonstrate.
- A striking feature in the tissue and joint fluid is the extreme clonal expansion that persists even during treatment with methotrexate. Paradoxically, however, there is no evidence to indicate that one or a few structurally or cognitively related T-cell clones drive the process, as is the case for most autoimmune diseases. Rather, it appears that a succession of different clones sequentially dominate the repertoire of infiltrating T cells.
- Evidence is emerging that innate immune responses may be triggered in PsA, with signalling through the Toll-like receptors or NK receptors on memory effector T cells. Indeed, there is evidence of nonclonally specific infiltration or local expansion in the tissues and joint fluids. However, it remains to be explained why only certain clones are expanded in an inflammatory site.

In a summary illustration of the pathogenesis of PsA (Figure 3), the key elements are the operation of environmental triggers on a genetically and environmentally primed host. Both non-MHC and MHC polymorphisms associated with susceptibility predispose the TCR repertoire to autoreactivity and recognition of target self-peptides that are likely

to be expressed in target tissues. Additionally, prior response to exogenous ligands encoded by pathogens results in memory effector CD8⁺ T cells. Furthermore, prior episodes of inflammation may similarly result in memory effector CD8⁺ T cells that recognize stress-related self-antigens. The threshold for triggering these memory effector T cells by cross-reacting structures expressed or present in additional encounters with pathogens or stress activates the CD8⁺ memory-effector T cells and initiates pathways of inflammation mediated by the expression of transcription factors such as nuclear factor- κ B and activator protein-1. This results in the tissue response of PsA that is also manifest histopathologically and by imaging techniques.

Therapy

In view of the still emerging picture of the details of these biological events that are responsible for PsA, it is somewhat premature to envision the ideal properties of drugs for use in this disease. However, some more peripheral questions appear to be answered in the negative, for instance a drug that depletes CD4⁺ T cells is unlikely to be effective in established PsA. Similarly, it would not be anticipated that a B-cell-depleting agent such as rituximab would be efficacious. There is also some question about the role that tolerance-inducing agents would have, because the fundamental T-cell alteration does not appear to be due to one or a few autoimmune driver T-cell clones that could readily be eliminated. Conversely, in view of the role played by T-cell activation, proliferation and differentiation, and cytokine release by T cells and macrophages, there is growing support

for agents that interfere with cytokine pathways, T-cell responsiveness and macrophage effects. Anti-TNF- α inhibition is an example of this approach applied to macrophages. Agents may be effective at the level of blocking naïve T-cell activation, for example with agents such as abatacept, or even more likely by blocking the response of NK and CD8⁺ effector T cells to innate immune danger signals.

Nonspecific

Methotrexate is the prototype of an effective nonspecific agent. Some insight into the role of methotrexate in PsA was provided by the TCR repertoire studies, in which clinical response was accompanied by a significant depletion of the polyclonal nonclonally expanded component of the T-cell infiltrate, whereas the monoclonal expansions persisted, perhaps accounting for the clinical rebound often seen after stopping the drug. This suggested that the effect of methotrexate in PsA was immunomodulatory, probably by diminishing chemokine production [35], but certainly not tolerance induction.

Specific

The most significant advance in terms of therapy in PsA and indeed in psoriasis is the development of anti-TNF- α inhibition. These agents have been remarkably successful in controlling all aspects of disease. Not all patients respond, but some experience significant adverse effects and for most patients treatment must be continued long term in order to maintain the therapeutic effect. Having demonstrated clinical efficacy, the pharmaceutical companies are no longer supporting clinical trials in PsA of these existing anti-TNF- α products, even though there are major unanswered questions with regard to optimal usage. For example, we do not know whether anti-TNF- α products work best in conjunction with methotrexate, and neither do we know whether early introduction of an anti-TNF- α product is more likely to result in long-lasting and possibly drug-free remission. Finally, the recent and unexpected reports of psoriasis developing for the first time in patients on anti-TNF- α therapy are intriguing [36,37]. Although the clinical psoriasis phenotype is often not plaque but the more distinctive pustular form, the pathogenesis of this response is currently obscure, but it further emphasizes the heterogeneity of PsA and the involvement of innate immune mechanisms.

Other specific therapies are showing promising initial responses. These include anti-IL-23 and abatacept (cytotoxic T-lymphocyte antigen 4-immunoglobulin), a naïve T-cell costimulatory blocker that has been licensed for use in RA. Improved understanding of pathogenic mechanism in PsA will undoubtedly serve to open up additional therapeutic opportunities.

Conclusions

Current evidence suggests that PsA occurs in a genetically primed individual in whom stress or enthesal-derived antigens may perturb the immune response, resulting in

angiogenesis, T-cell infiltration and cytokine release. Further detailed analysis testing this hypothesis is required.

Competing interests

The authors declare that they have no competing interests.

References

1. Costello P, Bresnihan B, O'Farrelly C, FitzGerald O: **Predominance of CD8+ T lymphocytes in psoriatic arthritis.** *J Rheumatol* 1999, **26**:1117-1124.
2. Snowden JA, Heaton DC: **Development of psoriasis after syngeneic bone marrow transplant from psoriatic donor: further evidence for adoptive autoimmunity.** *Br J Dermatol* 1997, **137**:130-132.
3. Winchester R, Minevich G, Kane D, Bresnihan B, Greenberg D, FitzGerald O: **Heterogeneity of the psoriasis phenotype revealed by HLA class I haplotype associations in psoriatic arthritis and psoriasis.** *Clin Immunol* 2008, **127**(Suppl 1):S88-S89.
4. Winchester R: **Genetics of psoriasis and psoriatic arthritis.** In *Psoriatic and Reactive Arthritis - A Companion to Rheumatology*. Edited by Ritchlin CT, FitzGerald O. Amsterdam, The Netherlands: Elsevier; 2007.
5. Ho PY, Barton A, Worthington J, Plant D, Griffiths CE, Young HS, Bradburn P, Thomson W, Silman AJ, Bruce IN: **Investigating the role of the HLA-Cw*06 and HLA-DRB1 genes in susceptibility to psoriatic arthritis: comparison with psoriasis and undifferentiated inflammatory arthritis.** *Ann Rheum Dis* 2008, **67**:677-682.
6. Hammer RE, Maika SD, Richardson JA, Tang JP, Taurog JD: **Spontaneous inflammatory disease in transgenic rats expressing HLA-B27 and human beta 2m: an animal model of HLA-B27-associated human disorders.** *Cell* 1990, **63**:1099-1112.
7. Costello PJ, Winchester RJ, Curran SA, Peterson KS, Kane DJ, Bresnihan B, FitzGerald OM: **Psoriatic arthritis joint fluids are characterized by CD8 and CD4 T cell clonal expansions that appear antigen driven.** *J Immunol* 2001, **166**:2878-2886.
8. Curran SA, FitzGerald OM, Costello PJ, Selby JM, Kane DJ, Bresnihan B, Winchester R: **Nucleotide sequencing of psoriatic arthritis tissue before and during methotrexate administration reveals a complex inflammatory T cell infiltrate with very few clones exhibiting features that suggest they drive the inflammatory process by recognizing autoantigens.** *J Immunol* 2004, **172**:1935-1944.
9. Turner SJ, Doherty PC, McCluskey J, Rossjohn J: **Structural determinants of T-cell receptor bias in immunity.** *Nat Rev* 2006, **6**:883-894.
10. Nelson GW, Martin MP, Gladman D, Wade J, Townsdales J, Carrington M: **Cutting edge: heterozygote advantage in autoimmune disease: hierarchy of protection/susceptibility conferred by HLA and killer Ig-like receptor combinations in psoriatic arthritis.** *J Immunol* 2004, **173**:4273-4276.
11. Pattison E, Harrison BJ, Griffiths CE, Silman AJ, Bruce IN: **Environmental risk factors for the development of psoriatic arthritis: results from a case-control study.** *Ann Rheum Dis* 2008, **67**:672-676.
12. Veale D, Yanni G, Rogers S, Barnes L, Bresnihan B, FitzGerald O: **Reduced synovial membrane macrophage numbers, ELAM-1 expression, and lining layer hyperplasia in psoriatic arthritis as compared with rheumatoid arthritis.** *Arthritis Rheum* 1993, **36**:893-900.
13. Kruithof E, Baeten D, De Rycke L, Vandooren B, Foell D, Roth J, Canete JD, Boots AM, Veys EM, De Keyser F: **Synovial histopathology of psoriatic arthritis, both oligo- and polyarticular, resembles spondyloarthritis more than it does rheumatoid arthritis.** *Arthritis Res Ther* 2005, **7**:R569-R580.
14. Danning CL, Illei GG, Hitchon C, Greer MR, Boumpas DT, McInnes IB: **Macrophage-derived cytokine and nuclear factor kappaB p65 expression in synovial membrane and skin of patients with psoriatic arthritis.** *Arthritis Rheum* 2000, **43**:1244-1256.
15. Pene J, Chevalier S, Preisser L, Venereau E, Guilleux MH, Ghannam S, Moles JP, Danger Y, Ravon E, Lesaux S, Yssel H, Gascan H: **Chronically inflamed human tissues are infiltrated**

- by highly differentiated Th17 lymphocytes. *J Immunol* 2008, **180**:7423-7430.
16. van Kuijk AW, Reinders-Blankert P, Smeets TJ, Dijkmans BA, Tak PP: **Detailed analysis of the cell infiltrate and the expression of mediators of synovial inflammation and joint destruction in the synovium of patients with psoriatic arthritis: implications for treatment.** *Ann Rheum Dis* 2006, **65**:1551-1557.
 17. Canete JD, Santiago B, Cantaert T, Sanmarti R, Palacin A, Celis R, Graell E, Gil-Torregrosa B, Baeten D, Pablos JL: **Ectopic lymphoid neogenesis in psoriatic arthritis.** *Ann Rheum Dis* 2007, **66**:720-726.
 18. Fearon U, Grosios K, Fraser A, Reece R, Emery P, Jones PF, Veale DJ: **Angiopoietins, growth factors, and vascular morphology in early arthritis.** *J Rheumatol* 2003, **30**:260-268.
 19. Ritchlin CT, Haas-Smith SA, Li P, Hicks DG, Schwarz EM: **Mechanisms of TNF-alpha- and RANKL-mediated osteoclastogenesis and bone resorption in psoriatic arthritis.** *J Clin Invest* 2003, **111**:821-831.
 20. Vandooren B, Cantaert T, Noordenbos T, Tak PP, Baeten D: **The abundant synovial expression of the RANK/RANKL/osteoprotegerin system in peripheral spondylarthritis is partially disconnected from inflammation.** *Arthritis Rheum* 2008, **58**:718-729.
 21. Viguier M, Richette P, Aubin F, Beylot-Barry M, Lahfa M, Bedane C, Delesalle F, Richard-Lallemand MA, Delaporte E, Dubertret L, Bardin T, Bachelez H: **Onset of psoriatic arthritis in patients treated with efalizumab for moderate to severe psoriasis.** *Arthritis Rheum* 2008, **58**:1796-1802.
 22. Taylor W, Gladman D, Helliwell P, Marchesoni A, Mease P, Mielants H: **Classification criteria for psoriatic arthritis: development of new criteria from a large international study.** *Arthritis Rheum* 2006, **54**:2665-2673.
 23. Kane D, Stafford L, Bresnihan B, FitzGerald O: **A prospective, clinical and radiological study of early psoriatic arthritis: an early synovitis clinic experience.** *Rheumatology (Oxford)* 2003, **42**:1460-1468.
 24. Welsing PM, van Gestel AM, Swinkels HL, Kiemeny LA, van Riel PL: **The relationship between disease activity, joint destruction, and functional capacity over the course of rheumatoid arthritis.** *Arthritis Rheum* 2001, **44**:2009-2017.
 25. Gladman DD, Mease PJ, Ritchlin CT, Choy EH, Sharp JT, Ory PA, Perdok RJ, Sasso EH: **Adalimumab for long-term treatment of psoriatic arthritis: forty-eight week data from the adalimumab effectiveness in psoriatic arthritis trial.** *Arthritis Rheum* 2007, **56**:476-488.
 26. Mease PJ, Kivitz AJ, Burch FX, Siegel EL, Cohen SB, Ory P, Salonen D, Rubenstein J, Sharp JT, Tsuji W: **Etanercept treatment of psoriatic arthritis: safety, efficacy, and effect on disease progression.** *Arthritis Rheum* 2004, **50**:2264-2272.
 27. Ng CT, Gibbs A, Murray BF, Brady JJ, Bresnihan B, Veale DJ, McKenna MJ, FitzGerald O: **Bone biomarkers and bone density measurements in patients with inflammatory arthritis prior to and following anti-TNF therapy.** *Ann Rheum Dis* 2008, **67**(Suppl II):525.
 28. Wiell C, Szkudlarek M, Hasselquist M, Moller JM, Vestergaard A, Norregaard J, Terslev L, Ostergaard M: **Ultrasonography, magnetic resonance imaging, radiography, and clinical assessment of inflammatory and destructive changes in fingers and toes of patients with psoriatic arthritis.** *Arthritis Res Ther* 2007, **9**:R119.
 29. Balint PV, Kane D, Wilson H, McInnes IB, Sturrock RD: **Ultrasonography of enthesal insertions in the lower limb in spondyloarthropathy.** *Ann Rheum Dis* 2002, **61**:905-910.
 30. Kane D, Greaney T, Bresnihan B, Gibney R, FitzGerald O: **Ultrasonography in the diagnosis and management of psoriatic dactylitis.** *J Rheumatol* 1999, **26**:1746-1751.
 31. McGonagle D, Gibbon W, O'Connor P, Green M, Pease C, Emery P: **Characteristic magnetic resonance imaging enthesal changes of knee synovitis in spondylarthropathy.** *Arthritis Rheum* 1998, **41**:694-700.
 32. McGonagle D, Conaghan PG, Emery P: **Psoriatic arthritis: a unified concept twenty years on.** *Arthritis Rheum* 1999, **42**:1080-1086.
 33. Tan AL, Benjamin M, Toumi H, Grainger AJ, Tanner SF, Emery P, McGonagle D: **The relationship between the extensor tendon entheses and the nail in distal interphalangeal joint disease in psoriatic arthritis: a high-resolution MRI and histological study.** *Rheumatology (Oxford)* 2007, **46**:253-256.
 34. Healy PJ, Groves C, Chandramohan M, Helliwell PS: **MRI changes in psoriatic dactylitis: extent of pathology, relationship to tenderness and correlation with clinical indices.** *Rheumatology (Oxford)* 2008, **47**:92-95.
 35. Chan ES, Cronstein BN: **Molecular action of methotrexate in inflammatory diseases.** *Arthritis Res* 2002, **4**:266-273.
 36. Kary S, Worm M, Audring H, Huscher D, Renelt M, Sorensen H, Stander E, Maass U, Lee H, Sterry W, Burmester GR: **New onset or exacerbation of psoriatic skin lesions in patients with definite rheumatoid arthritis receiving tumour necrosis factor alpha antagonists.** *Ann Rheum Dis* 2006, **65**:405-407.
 37. Sfikakis PP, Iliopoulos A, Elezoglou A, Kittas C, Stratigos A: **Psoriasis induced by anti-tumor necrosis factor therapy: a paradoxical adverse reaction.** *Arthritis Rheum* 2005, **52**:2513-2518.