

## Both GA2, GM2, and GD2 synthases and GM1b, GD1a, and GT1b synthases are single enzymes in Golgi vesicles from rat liver

(glycosphingolipid/ganglioside/biosynthesis/*N*-acetylgalactosaminyltransferase/sialyltransferase)

GOTTFRIED POHLENTZ, DIETER KLEIN, GÜNTER SCHWARZMANN, DORIS SCHMITZ, AND KONRAD SANDHOFF\*

\*Institut für Organische Chemie und Biochemie der Universität Bonn, Gerhard-Domagk-Strasse 1, D-5300 Bonn 1, Federal Republic of Germany

Communicated by Saul Roseman, March 30, 1988

**ABSTRACT** Competition experiments using lactosylceramide, ganglioside GM3 and ganglioside GD3 as substrates, as well as mutual inhibitors for ganglioside *N*-acetylgalactosaminyltransferase, in Golgi vesicles derived from rat liver suggested that *N*-acetylgalactosamine transfer to these three respective compounds, leading to gangliosides GA2, GM2, and GD2, respectively, is catalyzed by one enzyme. Analogous studies with gangliosides GA1, GM1, and GD1b as glycolipid acceptors in sialyltransferase assays indicated GM1b, GD1a, and GT1b synthases to be identical. These results are incorporated into a model for ganglioside biosynthesis and its regulation.

Gangliosides are a group of complex sialic acid-containing glycosphingolipids. First found in brain (1–4), they are now known to be ubiquitous in plasma membranes of all mammalian cells so far studied (5–10). Ganglioside biosynthesis occurs in the Golgi apparatus starting with glucosylceramide by sequential addition of galactose, *N*-acetylgalactosamine (GalNAc), and sialic acid to the growing oligosaccharide chain (for review, see ref. 11). These reactions are catalyzed by specific glycosyltransferases, many of which were studied and partially characterized in rat liver Golgi apparatus (12–21). Most major mammalian gangliosides derive from the a or b series (22). However, recently ganglioside biosynthesis through asialogangliosides was shown in homogenates of rat bone marrow cells (23) and in Golgi vesicles from rat liver (24). In the biosynthesis of all ganglioside series, glycosyltransferases that catalyze analogous reactions are needed; for example, GA2, GM2, and GD2 synthase [for enzyme nomenclature see Table 1; ganglioside nomenclature is adapted from Svennerholm (25)] all transfer GalNAc in  $\beta 1 \rightarrow 4$  linkage to galactose. Some of those enzymes (i.e., GM2 and GD2 synthase, GM1 and GD1b synthase, GD1a and GT1b synthase) were already suspected to be identical (26, 27). In our study the identity of GA2, GM2, and GD2 synthase and the identity of GM1b, GD1a, and GT1b synthase are proven by kinetic and competition experiments.

### MATERIALS AND METHODS

**Materials.** Uridine 5' diphospho-*N*-acetyl-D-[1-<sup>14</sup>C]galactosamine (UDP[<sup>14</sup>C]GalNAc, 2.22 GBq/mmol) and cytidine 5' monophospho-*N*-acetyl[4,5,6,7,8,9-<sup>14</sup>C]neuraminic acid (CMP[<sup>14</sup>C]NeuAc, 10.77 GBq/mmol) were purchased from Amersham and used after dilution with respective nonradioactive nucleotide sugars obtained from Sigma. Sephadex G-25 superfine and DEAE-Sephacel were from Pharmacia. Cytidine 5' diphosphocholine, Triton X-100, Triton CF-54, and bovine serum albumin were from Sigma. Pre-coated silica gel 60 thin-layer plates were from Merck, scintillation cocktail Pico Fluor 30 was from Packard, sodium

Table 1. Glycosphingolipid glycosyltransferase nomenclature

Transferase	Acceptor	EC no.	Name used in this paper
GalNAc-transferase	LacCer	2.4.1.-	GA2 synthase
	GM3	2.4.1.92	GM2 synthase
	GD3	2.4.1.-	GD2 synthase
Sialyltransferase	GM3	2.4.99.8	GD3 synthase
	GA1	2.4.99.-	GM1b synthase
	GM1	2.4.99.2	GD1a synthase
	GD1b	2.4.99.-	GT1b synthase

cadodylate and 2,5-diphenyloxazol were from Fluka, and x-ray film XAR-5 came from Eastman-Kodak. Male rats of the Wistar strain (300–350 g) were procured from Hagemann (Extetal, F.R.G.). All other reagents and solvents used were of analytical-grade quality.

**Preparation of Golgi Vesicles.** Golgi-rich vesicles were isolated from rat liver, essentially by the method of Sandberg *et al.* (28) as described in detail (29, 30). Enrichments of Golgi-specific enzymes (glycosyltransferases) were 50- to 80-fold. Contamination with other cellular membranes (plasma membrane, lysosomes, endoplasmic reticulum) was <5% (29).

**Assays of Glycosyltransferases.** (i) *N*-Acetylgalactosaminyltransferase (GalNAc-transferase) (GA2, GM2, and GD2 synthase). In a total volume of 50  $\mu$ l, assay solutions contained glycolipid acceptor [Gal $\beta 1 \rightarrow 4$ Glc $\beta 1 \rightarrow 1$ Cer (LacCer), GM3, GD3] to 200  $\mu$ M, 0.15% (wt/vol) Triton X-100, 64 mM sodium cacodylate/hydrochloric acid buffer (pH 7.35), 10 mM cytidine 5' diphosphocholine, 20 mM MnCl<sub>2</sub>, 200  $\mu$ M UDP[<sup>14</sup>C]GalNAc (25,000–45,000 cpm/nmol), and 50  $\mu$ g of Golgi protein. Incubation was for 15 min at 37°C. (ii) *N*-Acetylneuraminyltransferase (sialyltransferase) (GM1b, GD1a, and GT1b synthase or GD3 synthase). In a total volume of 50  $\mu$ l, assay solutions contained glycolipid acceptor (GA1, GM1, GD1b, or GM3) to 200  $\mu$ M, 0.3% (wt/vol) Triton CF-54, 150 mM sodium cacodylate/hydrochloric acid buffer (pH 6.6), 10 mM MgCl<sub>2</sub>, 10 mM 2-mercaptoethanol, 1 mM CMP[<sup>14</sup>C]NeuAc (5000–9000 cpm/nmol), and 50  $\mu$ g of Golgi protein. Incubation was for 15 min at 37°C.

Assays and product separation were executed as before (29). Separation of GM2 and GD2 was achieved on DEAE-Sephacel as described for GM1 and GD1a (31). Radioactivity of the products was determined in a liquid scintillation counter.

Rates of all reactions described here were linear with time, at least to 30 min, and linear with protein concentration to 75–

Abbreviations: GalNAc, *N*-acetylgalactosamine; LacCer, Gal $\beta 1 \rightarrow 4$ Glc $\beta 1 \rightarrow 1$ Cer; GalNAc-transferase, *N*-acetylgalactosaminyltransferase; CMP[<sup>14</sup>C]NeuAc, cytidine 5' monophospho-*N*-acetyl[4,5,6,7,8,9-<sup>14</sup>C]neuraminic acid; UDP[<sup>14</sup>C]GalNAc, uridine 5' diphospho-*N*-acetylgalactosamine. In Svennerholm nomenclature (25) for gangliosides, G = ganglioside, M = monosialo, D = disialo, T = trisialo, and arabic numerals indicate sequence of migration in thin-layer chromatograms.

\*To whom reprint requests should be addressed.

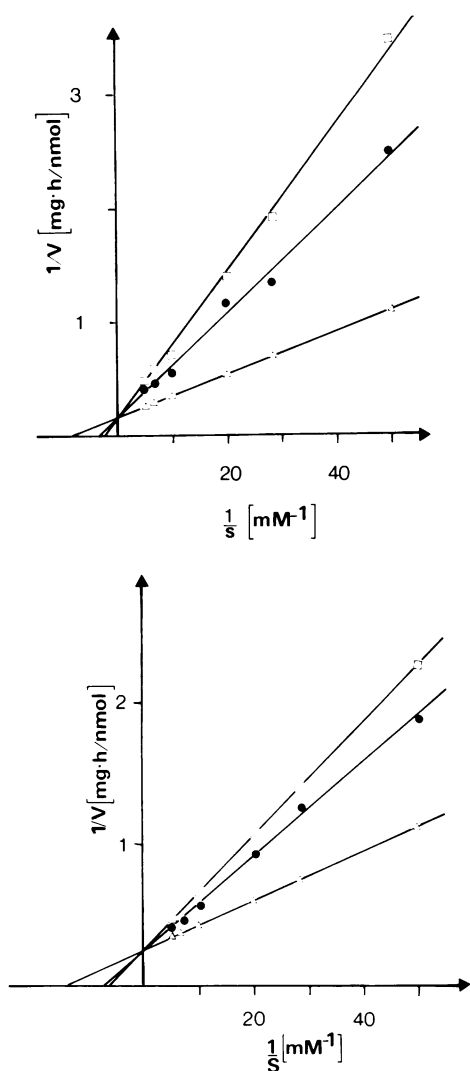

FIG. 1. Substrate dependency of GM2 (*Upper*) and GD2 (*Lower*) synthesis with and without the respective inhibitors GD3 and GM3. Under the described conditions GM3 (*Upper*) and GD3 (*Lower*) in various concentrations were incubated with UDP[<sup>14</sup>C]GalNAc and Golgi protein in the presence of 0 ( $\Delta$ ), 100 ( $\bullet$ ), and 150 ( $\square$ )  $\mu$ M inhibitor [GD3 (*Upper*) and GM3 (*Lower*)]. Separation and measurement of the products were as described. Figures show Lineweaver-Burk plots of the data.

100  $\mu$ g per assay depending on the Golgi preparation. Decrease of nucleotide sugar concentration during the 15-min incubation period was at most 1% and 6% for GalNAc-transferases and sialyltransferases, respectively. All experiments were done at least in duplicate, and mean values are presented in the figures and tables. Unless otherwise stated, SDs were <5%.  $K_m$  values presented are apparent  $K_m$  values determined in detergent-containing assays. Product identification was as described previously (24, 32).

## RESULTS

**GA2, GM2, and GD2 Synthase.** To prove that GM2 synthase and GD2 synthase are identical, competition experiments with GM3 as substrate and GD3 as inhibitor and vice versa were done. Fig. 1 clearly shows competitive inhibition of GM2 synthesis by GD3 and of GD2 synthesis by GM3.  $V_{max}$  values deviate <3% from each other at any inhibitor concentration (Table 2). If GM3 and GD3 were converted to GM2 and GD2, respectively, by the same enzyme, the

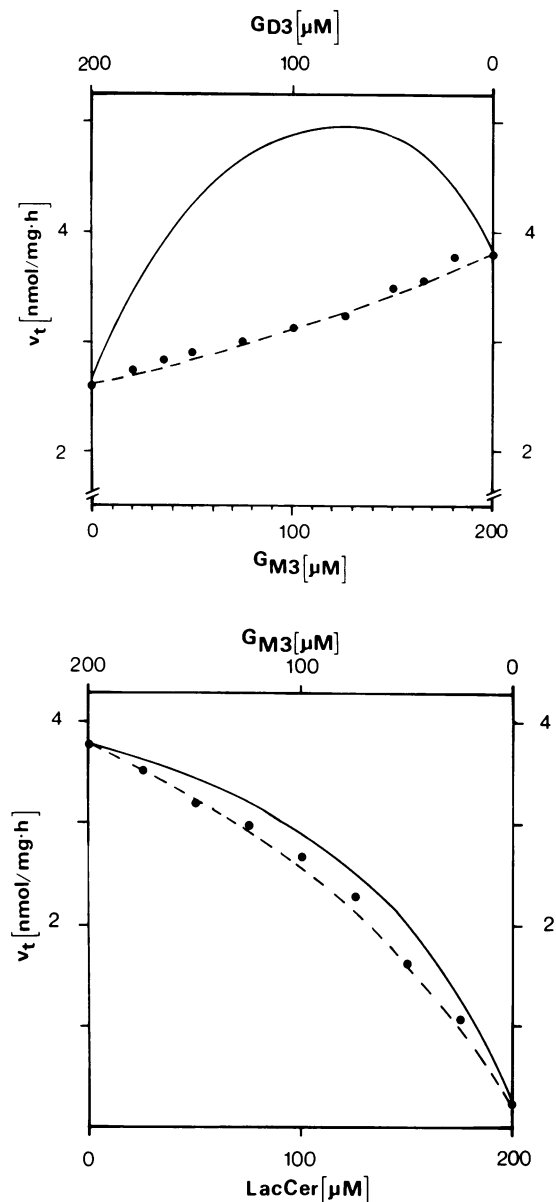

FIG. 2. Competition between GM3 and GD3 (*Upper*) and between LacCer and GM3 (*Lower*) in the GalNAc-transferase assay. As described, GM3 and GD3 (*Upper*) and LacCer and GM3 (*Lower*) were used as acceptors for GalNAc-transferase in various partial concentrations, keeping total substrate at 200  $\mu$ M. Total reaction velocities as experimentally determined ( $\bullet$ ) or as calculated for the different models elucidated in *Results* are plotted versus the partial substrate concentrations. Kinetic constants used are those described in *Results*. —,  $v_t$  calculated from Eq. 2 (two different enzymes); ---,  $v_t$  calculated from Eq. 3 (one enzyme).

inhibitor constant ( $K_i$ ) of either substrate would equal its  $K_m$  value.  $K_i$  can be calculated to

$$K_i = \frac{C_i}{\frac{K_{mi}}{K_m} - 1}, \quad [1]$$

where  $C_i$  is the inhibitor concentration and  $K_{mi}$  and  $K_m$  are the  $K_m$  values with and without inhibitor, respectively (33). Table 2 shows the  $K_m$  and  $K_i$  values for GM3 and GD3 from the above experiments. Deviations of the calculated inhibitor constants from the  $K_m$  values (<7% for GM3 and <3% for GD3) were in the range of accuracy of measurement—data suggesting that GM2 and GD2 synthesis is catalyzed by the same enzyme.

Table 2.  $V_{\max}$ ,  $K_m$ ,  $K_{mi}$ , and  $K_i$  values for GM2 and GD2 synthesis from the experiments of Fig. 1

$C_i, \mu\text{M}$	GM2 synthesis			GD2 synthesis		
	$V_{\max}^*$ , nmol per (mg·hr)	$K_m$ and $K_{mi}^*$ for GM3, $\mu\text{M}$	$K_i$ for GD3, $\mu\text{M}$	$V_{\max}^*$ , nmol per (mg·hr)	$K_m$ and $K_{mi}^*$ for GD3, $\mu\text{M}$	$K_i^\dagger$ for GM3, $\mu\text{M}$
0	6.2	117	—	3.9	68	—
100	6.3	289	68	3.9	130	109
150	6.3	385	66	3.8	152	120

$K_m$  and  $K_{mi}$ ,  $K_m$  values without and with inhibitor, respectively;  $K_i$ , inhibitor constant.  $C_i$ , inhibitor concentration—GD3 and GM3 were used as inhibitor for GM2 synthesis and GD2 synthesis, respectively.

\* $V_{\max}$ ,  $K_m$ , and  $K_{mi}$  values were calculated from Fig. 1 by linear regression. The correlation constants ( $c$ ) were  $1.000 > c > 0.996$ .

† $K_i$  values were calculated from Eq. 1.

For a final proof, both substrates GM3 and GD3 were used in the GalNAc-transferase assay at the same time at various partial concentrations, keeping total substrate concentration at 200  $\mu\text{M}$ . For two independent enzymes, each recognizing only one of two substrates a and b, total reaction velocity  $v_t$  can be calculated as the sum of two partial velocities  $v_a$  and  $v_b$ , given by their respective Michaelis equations:

$$v_t = v_a + v_b = \frac{V_a}{1 + \frac{K_a}{a}} + \frac{V_b}{1 + \frac{K_b}{b}} \quad [2]$$

If both substrates are glycosylated by the same enzyme and each substrate acts as competitive inhibitor of the other ( $K_m = K_i$ ), total velocity is given by the following equation (33):

$$v_t' = v_a' + v_b' = \frac{V_a}{1 + \frac{K_a}{a} \left(1 + \frac{b}{K_b}\right)} + \frac{V_b}{1 + \frac{K_b}{b} \left(1 + \frac{a}{K_a}\right)} \quad [3]$$

The total reaction velocities calculated from Eqs. 2 and 3 with  $K_m$  and  $V_{\max}$  values determined simultaneously with the same Golgi preparation (GM3,  $K_m = 110 \mu\text{M}$  and  $V_{\max} = 5.9 \text{ nmol/mg·hr}$ ; GD3,  $K_m = 71 \mu\text{M}$  and  $V_{\max} = 3.5 \text{ nmol/mg·hr}$ ) are shown in Fig. 2 Upper. The measured  $v_t$  values clearly fit those calculated for one enzyme. From such data we conclude that GM2 and GD2 are synthesized by the same active site of one enzyme from their respective precursors.

When an analogous experiment was done with LacCer and GM3 as glycolipid acceptors for GA2 and GM2 synthesis, respectively, a similar result was obtained (Fig. 2 Lower). Although the  $v_t$  plots calculated from Eqs. 1 and 2 do not

differ widely (due to great differences in  $K_m$  and  $V_{\max}$  for both substrates; LacCer,  $K_m = 437 \mu\text{M}$  and  $V_{\max} = 0.7 \text{ nmol/mg·hr}$ ; GM3,  $K_m = 109 \mu\text{M}$  and  $V_{\max} = 5.8 \text{ nmol/mg·hr}$ ) the experimentally determined  $v_t$  values follow those calculated for one active site.

The above results show that GA2, GM2, and GD2 synthesis is catalyzed by the same GalNAc-transferase.

**GM1b, GD1a, and GT1b Synthase.** To show competition of GM1 and GD1b, GM1 in various concentrations was incubated with and without 50  $\mu\text{M}$  GD1b with CMP[ $^{14}\text{C}$ ]NeuAc and Golgi protein as described. Reaction products were separated by TLC. GD1a was scraped from the plates, and its radioactivity was determined. The resulting Lineweaver-Burk plots of GD1a synthesis (Fig. 3 Left) clearly indicate competition between GM1 and GD1b. When both acceptors were used in sialyltransferase assay in various partial concentrations, keeping the total substrate concentration at 150  $\mu\text{M}$ , the measured  $v_t$  values clung to the curve calculated for one enzyme (Fig. 4 Left). These results indicate that GD1a and GT1b are synthesized by the same enzyme.

Similar experiments were done for GM1b and GD1a synthesis with their respective glycolipid acceptors GA1 and GM1. To show competitive inhibition Golgi vesicles were incubated with CMP[ $^{14}\text{C}$ ]NeuAc and various GM1 concentrations with and without 100  $\mu\text{M}$  GA1 as described. Again GD1a was determined as described above. Fig. 3 Right strongly indicates competition between GA1 and GM1.

The result of a competition experiment in which the partial concentrations of GA1 and GM1 were varied while the total concentration was kept at 150  $\mu\text{M}$  is shown in Fig. 4 Right. Again, the experimentally determined  $v_t$  values fit those calculated from Eq. 3 (one enzyme). The above results strongly suggest that GM1b, GD1a, and GT1b are synthesized by the same sialyltransferase.

**GD3 Synthase and GD1a Synthase.** The competition experiment in which the partial concentrations of two substrates were varied, keeping the total substrate concentration con-

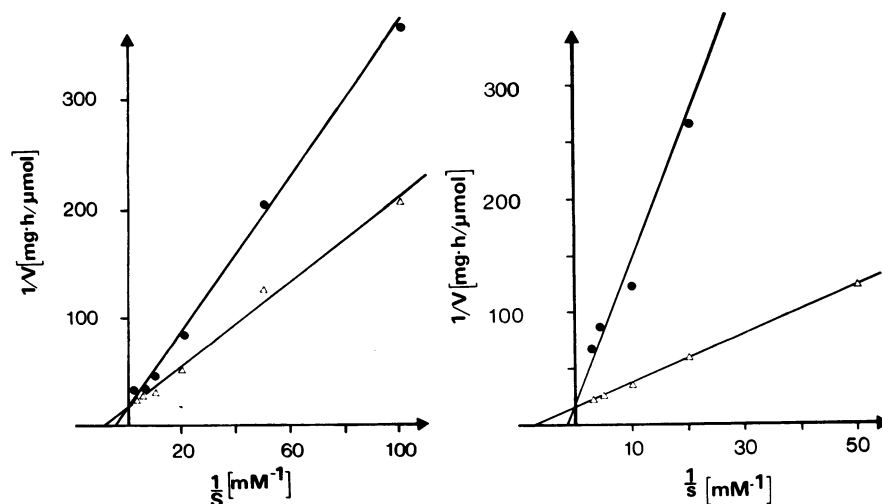

FIG. 3. Effect of GD1b (Left) and of GA1 (Right) on GD1a synthesis at various GM1 concentrations. Under the described conditions for sialyltransferase Golgi vesicles were incubated with 1 mM CMP[ $^{14}\text{C}$ ]NeuAc and the indicated amounts of GM1 with (●) and without (Δ) inhibitor [50  $\mu\text{M}$  GD1b (Left) and 100  $\mu\text{M}$  GA1 (Right)]. GD1a synthesis was determined as described. The Lineweaver-Burk plots obtained are shown.

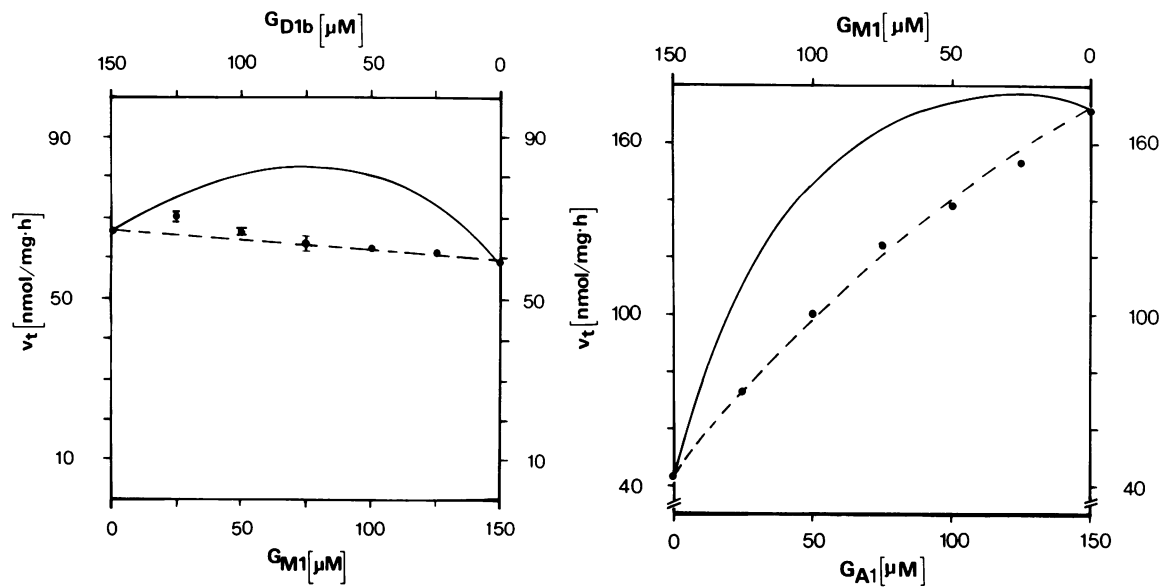

FIG. 4. Competition between GM1 and GD1b (*Left*) and between GA1 and GM1 (*Right*) in the sialyltransferase assay. As described, GM1 and GD1b (*Left*) and GA1 and GM1 (*Right*) were acceptors for sialyltransferase in various partial concentrations, keeping total substrate at 150  $\mu\text{M}$ . Kinetic constants were determined in parallel experiments with the Golgi preparation used in the respective competition experiments: GM1,  $K_m = 290 \mu\text{M}$  and  $V_{max} = 172 \text{ nmol/mg}\cdot\text{hr}$ ; GD1b,  $K_m = 111 \mu\text{M}$  and  $V_{max} = 116 \text{ nmol/mg}\cdot\text{hr}$  (*Left*). GA1,  $K_m = 59 \mu\text{M}$  and  $V_{max} = 241 \text{ nmol/mg}\cdot\text{hr}$ ; GM1,  $K_m = 97 \mu\text{M}$  and  $V_{max} = 68 \text{ nmol/mg}\cdot\text{hr}$  (*Right*). Total reaction velocities as experimentally determined or as calculated for the different models elucidated in *Results* are plotted versus the partial substrate concentrations. For explanation of symbols, see Fig. 2 legend.

stant, was used four times to prove enzyme identity. To show that this type of experiment also works to demonstrate the diversity of two enzymes, competition of GM3 and GM1 in sialyltransferase assay was studied. GM3 and GM1 act as glycolipid acceptors in GD3 and GD1a synthesis catalyzed by sialyltransferases supposed to be separate enzymes. As Fig. 5 shows, the experimentally determined  $v_t$  values, indeed, correspond to those calculated from Eq. 2—i.e., for two separate enzymes.

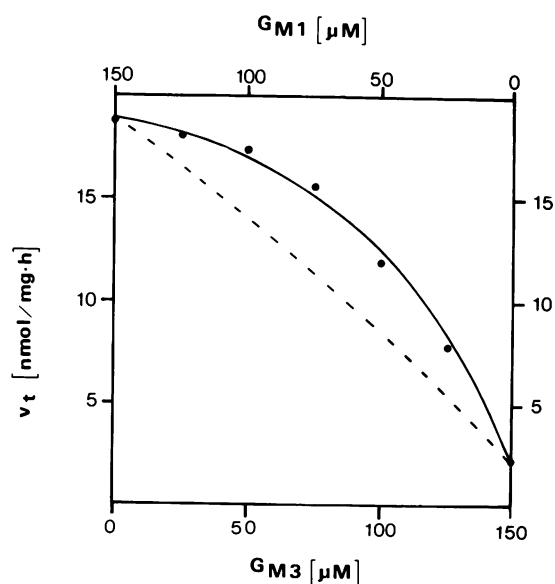

FIG. 5. Competition between GM3 and GM1 in the sialyltransferase assay. As described, GM3 and GM1 were acceptors for sialyltransferase in various partial concentrations, keeping total substrate at 150  $\mu\text{M}$ . In parallel experiments  $K_m$  and  $V_{max}$  values were determined with the same Golgi preparation by varying GM3 and GM1 concentrations, respectively (GM3,  $K_m = 130 \mu\text{M}$  and  $V_{max} = 4.1 \text{ nmol/mg}\cdot\text{hr}$ ; GM1,  $K_m = 93 \mu\text{M}$  and  $V_{max} = 31 \text{ nmol/mg}\cdot\text{hr}$ ). Total reaction velocities as experimentally determined or as calculated for the different models elucidated in *Results* are plotted versus the partial substrate concentrations. For explanation of symbols, see Fig. 2 legend.

## DISCUSSION

Biosynthesis of gangliosides has been investigated in a variety of microsomal or Golgi preparations from several tissues. The glycosyltransferases involved were studied for optimal assay conditions (detergent, pH, metal ions, etc.), kinetic properties ( $K_m$ ,  $V_{max}$ ), and orientation in the Golgi membrane (12–21, 24, 26, 29, 30). The identity of GM2 and GD2 synthase, GM1 and GD1b synthase, and GD1a and GT1b synthase was already assumed earlier (26, 27). In the present study we demonstrate that GA2, GM2, and GD2 and GM1b, GD1a, and GT1b are synthesized by the same GalNAc-transferase and sialyltransferase, respectively. Moreover, a negative proof for GD3 and GD1a synthesis is given, showing that the method used also allows distinction between two separate enzymes.

Data for GA2 and GM2 synthesis (Fig. 2 *Lower*), obtained from assay systems using LacCer and GM3 as acceptors, are not as compelling as those from all other competition experiments. This phenomenon, which has already been discussed previously (24), is probably due to the poor availability of LacCer to GalNAc-transferase in detergent-containing assays ( $K_m$  extremely high and  $V_{max}$  extremely low). This fact may also explain the observation of Yanagisawa *et al.* (34)—namely, that LacCer was not accepted by a partially purified UDP GalNAc, GM3 GalNAc-transferase, under their incubation conditions.

Our results lead to a suggested model of ganglioside biosynthesis and its regulation. The decision regarding which series a certain ganglioside molecule is directed toward (asialo, a, b, or c series) seems to be made by the sialyltransferases I–III (Fig. 6). Starting with LacCer, GM3, or GD3 (and possibly with GT3) biosynthesis of asialo-, a-, and b-series (and possibly c-series) gangliosides is catalyzed by the same set of enzymes (Fig. 6). GalNAc-transferase, galactosyltransferase II, sialyltransferase IV, and sialyltransferase V seem to recognize the carbohydrate “backbones” of their respective acceptors. The presence of one or two sialic acid residues bound to the inner galactose influences the kinetic properties of these glycosyltransferases (i.e., alters  $K_m$  and  $V_{max}$  values).

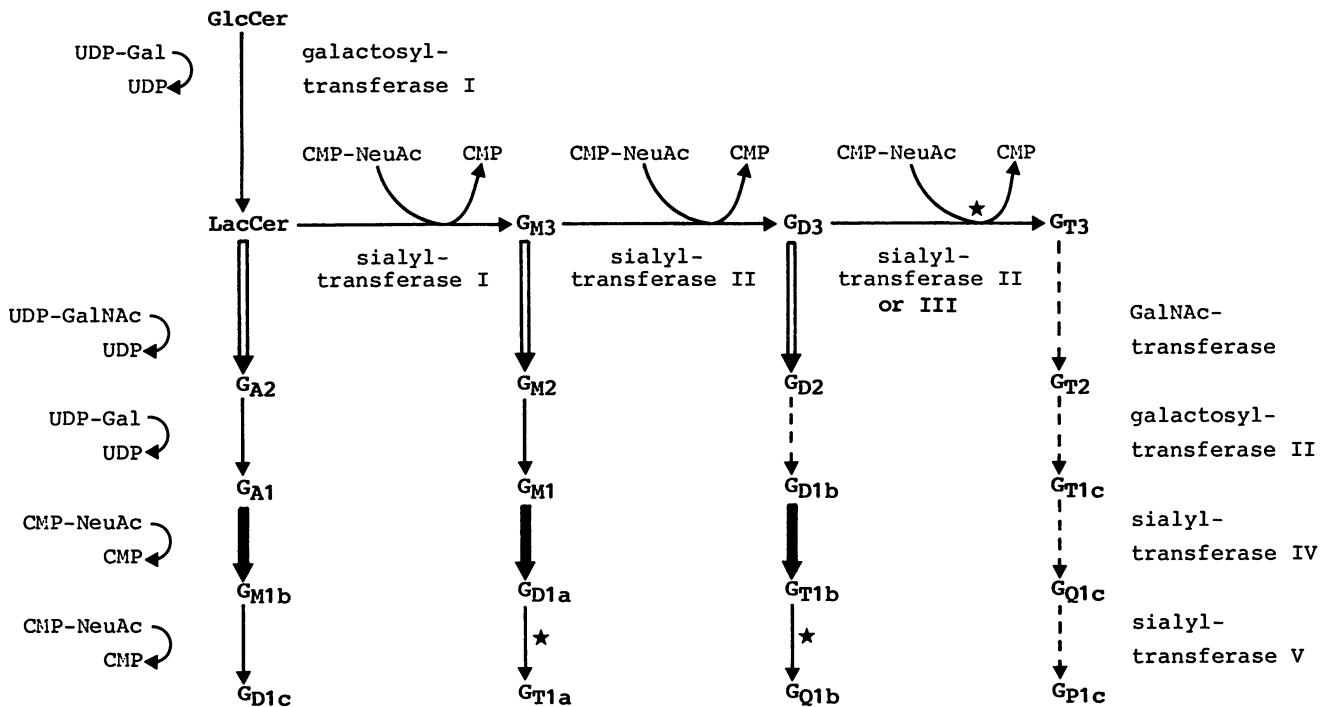

FIG. 6. Proposed model for ganglioside biosynthesis. In this model successive transfer of GalNAc, galactose, and sialic acid to LacCer, GM3, and GD3 (and possibly GT3) leading to the asialo, a, and b series (and possibly c series) gangliosides is catalyzed by the same set of glycosyltransferases. ----->, Reactions demonstrated in rat liver Golgi; reactions not yet demonstrated in rat liver Golgi; ==>, reactions catalyzed by one and the same GalNAc-transferase; ==>, reactions catalyzed by one and the same sialyltransferase. \*, Unpublished results (G.P.) from our laboratory. Cer, ceramide; GlcCer, glucosylceramide; UDP-Gal, uridine 5'-diphosphogalactose; CMP-NeuAc, cytidine 5' monophospho-N-acetylneuraminic acid; UDP-GalNAc, uridine 5' diphospho-N-acetylgalactosamine.

From this consideration we think the main regulation of ganglioside biosynthesis (either on a genetic or protein level) occurs in the sequence LacCer → GM3 → GD3 → GT3. This idea throws light on the results of Yusuf *et al.* (22), who looked for a feed-back inhibition in ganglioside biosynthesis by studying the effect of end-product gangliosides (such as GD1a, GT1b, and GQ1b) on GD3 and GM2 synthesis. GQ1b, the end-product of the b series, inhibited GD3 synthase (the starting enzyme of the b series) but had no inhibitory effect on GM2 synthesis. Unfortunately, they investigated the effect of end-product gangliosides on GM2 synthase and not on GM3 synthase (sialyltransferase I; Fig. 6), which, according to our model, is the starting enzyme of the a series. Thus, no specific inhibition by, for example, GD1a could be found. Further studies are much needed, however, to test specific aspects of this suggested model of ganglioside biosynthesis.

This work was financially supported by the Fonds der Chemischen Industrie and by Deutsche Forschungsgemeinschaft.

- Klenk, E. (1942) *Hoppe-Seyler's Z. Physiol. Chem.* **273**, 76–86.
- Lowden, J. A. & Wolfe, L. S. (1964) *Can. J. Biochem.* **42**, 1587–1594.
- Derry, D. M. & Wolfe, L. S. (1967) *Science* **158**, 1450–1452.
- Hamberger, A. & Svennerholm, L. (1971) *J. Neurochem.* **18**, 1821–1829.
- Ledeen, R., Salsman, K. & Cabrera, M. (1968) *Biochemistry* **7**, 2287–2295.
- Puro, K., Maury, P. & Huttunen, J. K. (1969) *Biochim. Biophys. Acta* **187**, 230–235.
- Wherret, J. R. (1973) *Biochim. Biophys. Acta* **187**, 63–73.
- Keenan, T. W. & Doak, R. L. (1973) *FEBS Lett.* **37**, 124–128.
- Wiegandt, H. (1973) *Hoppe-Seyler's Z. Physiol. Chem.* **354**, 1049–1056.
- Fishman, P. H., Max, S. R., Tallman, J. F., Brady, R. O., MacLaren, N. K. & Cornblath, M. (1975) *Science* **187**, 68–70.
- Schachter, H. & Roseman, S. (1980) in *The Biochemistry of Glycoproteins & Proteoglycans*, ed. Lennarz, W. J. (Plenum, New York), pp. 85–160.
- Keenan, T. W., Morré, D. J. & Basu, S. (1974) *J. Biol. Chem.* **249**, 310–315.
- Wilkinson, F. E., Morré, D. J. & Keenan, T. W. (1976) *J. Lipid Res.* **17**, 146–153.
- Richardson, C.-L., Keenan, T. W. & Morré, D. J. (1977) *Biochim. Biophys. Acta* **488**, 88–96.
- Eppler, C. M., Morré, D. J. & Keenan, T. W. (1980) *Biochim. Biophys. Acta* **619**, 318–331.
- Senn, H. J., Cooper, C., Warnke, P. C., Wagner, M. & Decker, K. (1981) *Eur. J. Biochem.* **120**, 59–67.
- Senn, H.-J., Wagner, M. & Decker, K. (1983) *Eur. J. Biochem.* **135**, 231–236.
- Kaplan, F. & Hechtman, P. (1983) *J. Biol. Chem.* **258**, 770–776.
- Busam, K. & Decker, K. (1986) *Eur. J. Biochem.* **160**, 23–30.
- Klein, D., Pohlentz, G., Schwarzmann, G. & Sandhoff, K. (1987) *Eur. J. Biochem.* **167**, 417–424.
- Basu, M., De, T., Das, K. K., Kyle, J. W., Chon, H.-C., Schaeper, R. J. & Basu, S. (1987) *Methods Enzymol.* **138**, 575–607.
- Yusuf, H. K. M., Schwarzmann, G., Pohlentz, G. & Sandhoff, K. (1987) *Biol. Chem. Hoppe-Seyler* **368**, 455–462.
- Taki, T., Kamada, R. & Matsumoto, M. (1982) *J. Biochem.* **91**, 665–674.
- Pohlentz, G., Klein, D., Schwarzmann, G., Schmitz, D. & Sandhoff, K. (1988) *Biol. Chem. Hoppe-Seyler* **369**, 55–63.
- Svennerholm, L. (1963) *J. Neurochem.* **10**, 613–623.
- Cumar, F. A., Tallmann, J. F. & Brady, R. O. (1972) *J. Biol. Chem.* **247**, 2322–2327.
- Pacuszka, T., Duffard, R. O., Nishimura, R. N., Brady, R. O. & Fishman, P. H. (1978) *J. Biol. Chem.* **253**, 5839–5846.
- Sandberg, P.-O., Marzella, L. & Glaumann, H. (1980) *Exp. Cell Res.* **130**, 393–400.
- Yusuf, H. K. M., Pohlentz, G., Schwarzmann, G. & Sandhoff, K. (1983) *Eur. J. Biochem.* **134**, 47–54.
- Yusuf, H. K. M., Pohlentz, G. & Sandhoff, K. (1983) *Proc. Natl. Acad. Sci. USA* **80**, 7075–7079.
- Scheel, G., Acevedo, E., Conzelmann, E., Nehr Korn, H. & Sandhoff, K. (1982) *Eur. J. Biochem.* **127**, 245–253.
- Sonderfeld, S., Conzelmann, E., Schwarzmann, G., Burg, J., Hinrichs, U. & Sandhoff, K. (1985) *Eur. J. Biochem.* **149**, 247–255.
- Dixon, M. & Webb, E. C. (1979) *Enzymes* (Longman, London), p. 334.
- Yanagisawa, K., Taniguchi, N. & Makita, A. (1987) *Biochim. Biophys. Acta* **919**, 213–220.