

A plant manganese superoxide dismutase is efficiently imported and correctly processed by yeast mitochondria

(complementation analyses/*Escherichia coli*/evolutionary conservation/*Nicotiana plumbaginifolia*)

CHRIS BOWLER, THIERRY ALLIOTTE*, MARC VAN DEN BULCKE, GUY BAUW, J. VANDEKERCKHOVE, M. VAN MONTAGU, AND D. INZÉ

Laboratorium voor Genetica, Rijksuniversiteit Gent, B-9000 Gent, Belgium

Contributed by M. Van Montagu, January 3, 1989

ABSTRACT In the plant *Nicotiana plumbaginifolia*, manganese superoxide dismutase (MnSOD) is synthesized in the cytoplasm as a preprotein and is subsequently translocated to the mitochondrial matrix with corresponding cleavage of an NH₂-terminal leader sequence. To determine whether the plant enzyme could replace the endogenous SOD activities of *Escherichia coli* and yeast, constructions have been made in appropriate vectors for expression of the preprotein and the mature MnSOD. These were introduced into SOD-deficient strains for complementation studies. In *E. coli*, both forms of the protein were shown to be active and able to complement SOD deficiency to different degrees. Expression of the preprotein in a yeast strain lacking a mitochondrial MnSOD resulted in a restoration of wild-type growth, only possible if the plant protein was being targeted to the mitochondria. Subsequent studies revealed that the protein was processed and that the leader sequence was cleaved at the identical position as recognized by the mitochondrial peptidase of plants. The components mediating mitochondrial import thus appear to be highly conserved between plants and yeast.

A by-product of aerobic metabolism is the generation of reduced oxygen species, which can be very toxic to an organism. In particular, hydroxyl radicals (OH[•]), generated from superoxide radicals (O₂^{•-}) and hydrogen peroxide (H₂O₂), are thought to be largely responsible for oxygen toxicity *in vivo* (1, 2). Superoxide dismutases (SODs; EC 1.15.1.1), catalyzing the dismutation of superoxide radicals to oxygen and H₂O₂, are important in providing protection against such oxidative stress. Three classes of SOD have been defined, as based on their metal cofactor: the copper/zinc, the manganese, and the iron forms (for review, see ref. 3). Prokaryotes possess the manganese form (MnSOD) and/or the iron form (FeSOD). Eukaryotes generally contain a MnSOD in the mitochondria and a copper/zinc-containing enzyme (Cu/ZnSOD) in the cytosol. The Fe- and MnSODs are very similar in their primary, secondary, and tertiary structure (see, for example, ref. 4), whereas the Cu/ZnSOD is unrelated.

We have recently isolated a full-length cDNA clone from *Nicotiana plumbaginifolia* encoding a MnSOD (5). This was obtained by first microsequencing the protein directly from two-dimensional gels of separated proteins from *N. plumbaginifolia* cell suspension cultures (6). From the deduced NH₂-terminal sequence an oligonucleotide probe was designed for screening a corresponding cDNA library. Analysis of the cDNA clone isolated revealed that the protein is synthesized as a precursor with a 24-amino acid transit peptide at its NH₂ terminus. Subsequent studies demon-

strated that this encodes a leader sequence for targeting the protein to the mitochondria.

Constructions designed to express both the preprotein and the mature protein were introduced into a SOD-deficient strain of *Escherichia coli* for complementation analyses. The *E. coli* mutant contains insertions in both MnSOD and FeSOD genes and lacks any detectable SOD activity (7). It is characterized by a hypersensitivity to oxidative stress (e.g., treatment with paraquat, oxygen, or H₂O₂). We have also studied complementation of a yeast mutant lacking a mitochondrial MnSOD (8), which relied on targeting the plant protein to the yeast mitochondria. The results reveal the ability of the plant MnSOD to replace the endogenous *E. coli* and yeast enzymes and, in addition, give a clear demonstration that a plant mitochondrial protein is imported and processed by plant and yeast mitochondria in a very similar manner.

MATERIALS AND METHODS

Strains and Vectors. SOD-deficient strains of *E. coli* and *Saccharomyces cerevisiae* used in this study have been described (7, 8).

Multiple-copy vectors for the expression of foreign genes under control of phage λ promoters were used for complementation experiments in *E. coli*. For expression of the preprotein, the MnSOD cDNA was isolated as a *Hpa* I/*Bam*HI fragment from pSOD1 (see Fig. 1a) and inserted into *Sma* I/*Bam*HI-digested pLK57 vector (9). We presumed that a fortuitous AGGA sequence present in the 5' untranslated sequence, 12 bases upstream from the MnSOD initiation codon (see Fig. 1b), would act as a Shine-Dalgarno sequence. This plasmid was designated pLKSODpp. A construction for expression of the mature protein was made as follows: pSOD1 was cut at the unique *Sac* II site and blunt-ended with T4 DNA polymerase. After the addition of octameric *Bgl* II linkers, the MnSOD sequence was cloned as a *Bgl* II/*Bam*HI fragment in the correct orientation into the *Bam*HI site of pLK63 (9). The resulting plasmid, pLKSODm, contains a translational fusion with four additional amino acids present at the NH₂ terminus of the mature protein (see Fig. 1b). Transcription termination signals were supplied by the phage fd terminator in both cases.

A plasmid designed to express the MnSOD preprotein in yeast under the control of the cytochrome *c* oxidase (*CYC1*) promoter was made by inserting a 915-base-pair (bp) *Hinc*II fragment from pSOD1 (see Fig. 1a) into the *Bam*HI site (blunt-ended with the DNA polymerase I Klenow fragment) of the yeast expression vector pEX2 (10). The resulting plasmid with the MnSOD open reading frame in the correct orientation was designated pYSODpp (see Fig. 4a). The

The publication costs of this article were defrayed in part by page charge payment. This article must therefore be hereby marked "advertisement" in accordance with 18 U.S.C. §1734 solely to indicate this fact.

Abbreviation: SOD, superoxide dismutase.

*Present address: L'Air Liquide S.A., 75, Quai d'Orsay, F-75321 Paris Cedex 07, France.

MnSOD sequence was flanked at the 3' end by the *CYC1* terminator.

Cell Growth Analysis. After the introduction of pLKSODm and pLKSODpp into the *E. coli sodAsodB* double mutant, complementation was assayed by studying growth in minimal medium, resistance to 100 μ M paraquat, and resistance to 3 mM H_2O_2 as described (7).

Plasmids pEX2 and pYSODpp were introduced into the MnSOD-deficient yeast strain (*sod1*) by lithium acetate transformation (11). Transformants were selected by using the plasmid-encoded *URA3* gene. Complementation experiments were based on growth in YPE medium (8) (1% yeast extract/2% Bacto-peptone/3% ethanol). In all cases, cell densities were measured at 600 nm.

Strains were cured of plasmid DNA by growing for several cycles under nonselective conditions. The absence of plasmid was confirmed by an inability to grow on uracil-deficient medium.

Protein Extraction and SOD Activity Assays. Cell lysates from *E. coli* and yeast were obtained by osmotic shock (12) and by disruption with glass beads (8), respectively. Total protein extracts from plant material were obtained as described (5). Protein concentrations were measured by the protein-dye binding assay (13) with a kit supplied by Bio-Rad.

Samples were separated on nondenaturing 10% polyacrylamide gels and the SOD activity was visualized on these gels by the *in situ* staining technique of Beauchamp and Fridovich (14). Inhibitor studies were performed directly on gels to distinguish between Cu/ZnSOD and MnSOD isozymes (data not shown) as described (5).

Protein Purification and NH₂-Terminal Sequencing. Total yeast proteins from the MnSOD-deficient strain carrying pYSODpp were enriched for MnSOD activity by heat treatment as described for human MnSOD (15). These were separated by NaDodSO₄/PAGE (16) and electroblotted to poly(4-vinyl-*N*-methylpyridinium iodide)-coated glass-fiber sheets (6). After visualization with fluorescamine (diluted 1:1000 in acetone), the band corresponding to the MnSOD protein was cut out and analyzed by gas-phase amino acid sequencing (Applied Biosystems).

RESULTS

Complementation of a SOD-Deficient *E. coli* Mutant by Expression of the Plant MnSOD. The *N. plumbaginifolia* MnSOD cDNA clone, called pSOD1, was originally obtained as a 996-bp cDNA inserted into the *Pst* I site of the plasmid pUC18 (5). The physical map of this cDNA is shown in Fig. 1a. For expression in *E. coli*, sequences encoding the preprotein and the mature protein were cloned into vectors designed for expression of foreign genes under control of phage λ promoters (9) (Fig. 1). Both constructions were introduced into an *E. coli* strain bearing insertionally inactivated *sodA* (MnSOD) and *sodB* (FeSOD) genes (7). As a result of SOD deficiency, the mutant is unable to grow in minimal medium and is hypersensitive to the superoxide-generating herbicide paraquat and to H_2O_2 . The absence of a *cI* repressor within this strain was expected to result in constitutive expression of the plant MnSOD from the phage promoters.

The results presented in Fig. 2, based on analysis of growth in minimal medium, resistance to 100 μ M paraquat, and

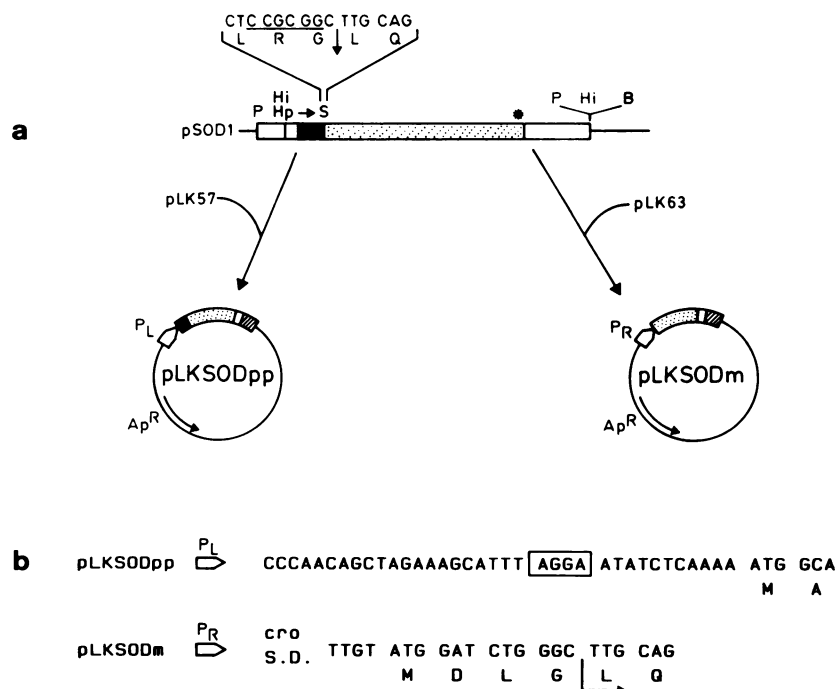

FIG. 1. Construction of vectors for expressing plant MnSOD in *E. coli*. (a) Physical map of MnSOD cDNA (pSOD1) isolated from *N. plumbaginifolia* and construction of plasmids for preprotein and mature protein expression. The cDNA insert of pSOD1 is shown, with untranslated sequences denoted by open boxes, transit peptide-encoding sequence by a solid box, and mature protein-encoding sequence by a stippled box (stop codon shown as asterisk). The sequence around the proteolytic processing site (denoted by an arrow) is given and the *Sac* II site is underlined. Final constructions for expression of the MnSOD preprotein (pLKSODpp) and mature protein (pLKSODm) are shown. Open arrows represent phage λ promoters (P_L and P_R). Hatched box represents phage λ terminators. B, *Bam*HI; Hi, *Hinc*II; Hp, *Hpa* I; P, *Pst* I; S, *Sac* II; Ap^R, ampicillin-resistance gene. (b) Sequences around the ATG initiation codons of pLKSODpp and pLKSODm. Sequence shown in pLKSODpp is derived from the MnSOD cDNA. The AGGA, presumably acting as a Shine-Dalgarno sequence, is boxed. The sequences shown for pLKSODm were generated during the cloning procedure. Ribosome-binding site is supplied by the *cro* Shine-Dalgarno sequence (*cro* S.D.). The four additional amino acids present at the NH₂ terminus of the mature protein are indicated. Amino acids are designated by the single-letter code.

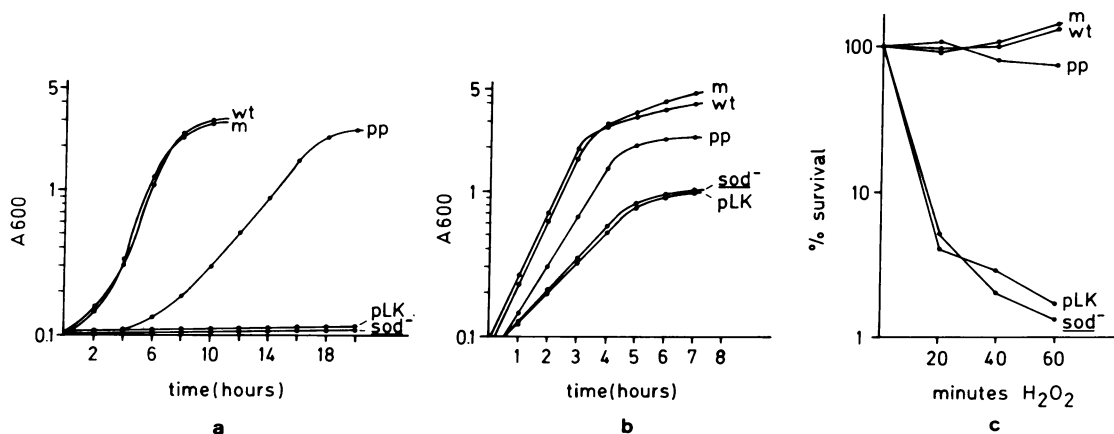

FIG. 2. Complementation analysis of *sodAsodB* *E. coli* mutant. (a) Aerobic growth in minimal medium. (b) Aerobic growth in rich medium containing 100 μ M paraquat. (c) Percentage survival of bacteria incubated in 3 mM H₂O₂ for 20, 40, and 60 min. Cell densities were measured at 600 nm. *sod*⁻, *sodAsodB* *E. coli* mutant; pp, *sodAsodB* containing plasmid pLKSODpp; m, *sodAsodB* containing plasmid pLKSODm; pLK, *sodAsodB* containing plasmid pLK57; wt, isogenic wild-type strain.

resistance to 3 mM H₂O₂ demonstrate that both the preprotein and the mature protein are able to complement the mutant phenotype. Under these conditions, the mature protein can apparently function as efficiently as the endogenous *E. coli* SODs, whereas the preprotein only complements with a lower efficiency (up to 70%). To rule out the possibility that the differences in complementation efficiency were due to slight differences in expression from the P_L and P_R promoters, the MnSOD cDNA sequences were also cloned into vectors with expression systems based on the *lac* promoter. Identical results were obtained from these (data not shown), confirming that the MnSOD sequences alone were determining the level of complementation. Although it has been reported that overexpression of human MnSOD in *E. coli* is optimal in the presence of exogenous Mn²⁺ (15), we found no difference between the complementation levels in the presence or absence of Mn²⁺ (data not shown).

Functional expression of the preprotein and the mature MnSOD was confirmed by assaying cell lysates obtained by osmotic shock on SOD activity gels (Fig. 3) (14). The native *E. coli* isozymes exist as homo- or heterodimers and thus give rise to three differentially migrating forms of the enzyme (17) (Fig. 3, lane wt). The mature form of the plant MnSOD migrates slightly faster than the bacterial heterodimer (lane m), whereas the MnSOD preprotein shows a surprisingly low electrophoretic mobility (lane pp), which could be due either to the high number of basic residues within the transit peptide (see Fig. 6) or to a multimeric subunit composition. The nature of this peculiarity was not further investigated.

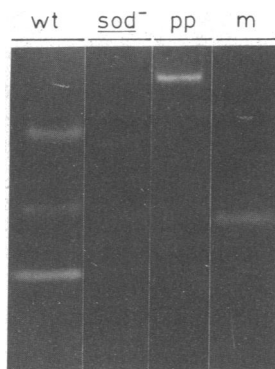

FIG. 3. SOD activity in *E. coli*. Samples contained 50 μ g of protein. The three bands in lane wt are *E. coli* dimeric MnSOD (upper band), dimeric FeSOD (lower band), and heterodimeric Mn/FeSOD (intermediate band). Abbreviations are the same as in Fig. 2.

Mitochondrial Targeting Can Be Demonstrated by Complementing a Yeast MnSOD-Deficient Mutant. *S. cerevisiae* possesses Cu/Zn and Mn isozymes of SOD, which are both nuclear encoded. The Cu/ZnSOD, is found in the cytosol and the MnSOD is located within the mitochondrial matrix (18, 19). A mutant bearing a disrupted MnSOD gene (*sod1*) has been isolated and is characterized by an inability to utilize nonfermentable carbon sources such as ethanol. This highlights the indispensable role of mitochondrial SOD for a eukaryote during aerobiosis—i.e., when oxygen-requiring mitochondrial activity is high. Although a cytosolic Cu/ZnSOD remains functional in this mutant, compartmentalization evidently precludes it from replacing the MnSOD. Thus, the prerequisites for successful complementation were that the MnSOD transit peptide could function in yeast to direct the protein into yeast mitochondria and that the imported protein could be active there. Since complementation would be assayed by following growth on ethanol, we chose to use an expression system with an ethanol-inducible cytochrome oxidase 1 (*CYC1*) promoter. The MnSOD preprotein sequence was cloned in a transcriptional fusion with the yeast *CYC1* promoter as described in *Materials and Methods*, and the final construction (pYSODpp) is shown in Fig. 4a. The introduction of plasmid pYSODpp into the MnSOD-deficient mutant restored the ability to grow on ethanol (Fig. 4b), and, moreover, growth was equivalent to wild type. This result is highly suggestive of efficient targeting.

Cell lysates from the complemented mutant were tested for SOD activity on nondenaturing polyacrylamide gels, which showed that the plant MnSOD activity migrated similarly to the endogenous MnSOD activity in the wild-type yeast (Fig. 4c). Both the yeast and the plant MnSOD migrate as one major band, each with lower mobility than the two yeast Cu/ZnSOD complexes. Importantly, the MnSOD activity in protein extracts from *N. plumbaginifolia* also migrates to the same position, an observation that hints at similar processing and subunit composition of the protein in plants and yeast. Curing the strain of the pYSODpp vector by successive cycles of growth on nonselective medium resulted in loss of the wild-type phenotype (Fig. 4b) and a loss of MnSOD activity in cell lysates (Fig. 4c).

These physiological assays for enzyme compartmentalization together with the observed mobility differences on polyacrylamide gels between the preprotein expressed in *E. coli* (Fig. 3, lane pp) and yeast [Fig. 4, lane *sod1*(pYSODpp)] strongly suggest that the MnSOD preprotein is efficiently imported into yeast mitochondria and processed into the mature form.

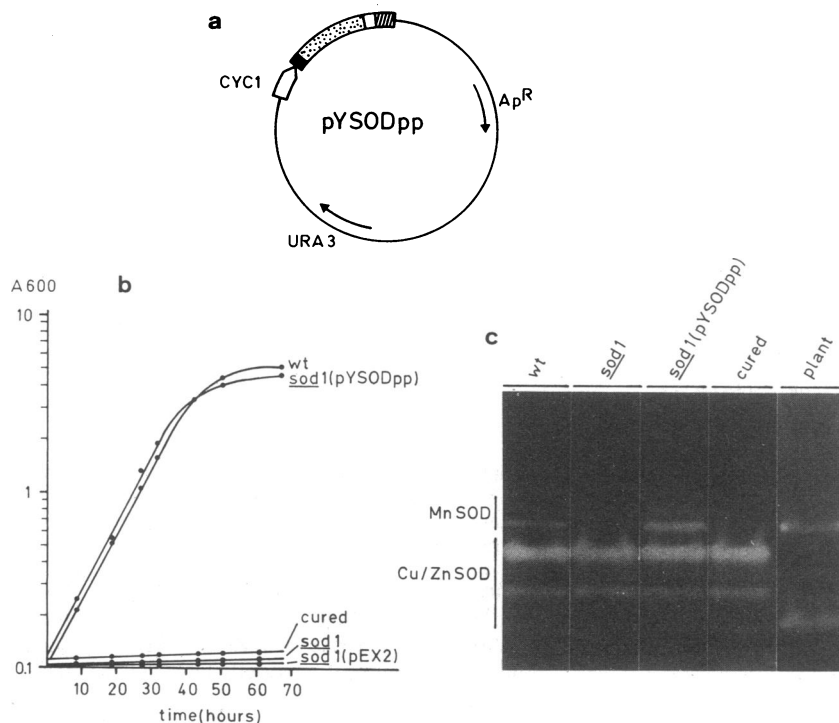

FIG. 4. Complementation of a MnSOD-deficient yeast strain with a construction designed for expressing the *N. plumbaginifolia* MnSOD preprotein. (a) Final construction with the plant MnSOD preprotein flanked at the 5' end by the ethanol-inducible cytochrome *c* oxidase (*CYC1*) promoter (open arrow) and at the 3' end by the *CYC1* terminator (hatched box). The plant MnSOD is denoted as in Fig. 1. *Ap^R*, ampicillin-resistance gene; *URA3*, selection for uracil prototrophy in yeast. (b) Growth of yeast strains in YPE. (c) SOD activity gels. Yeast samples contain 50 μ g of protein. Plant sample contains 200 μ g of total protein. MnSOD and Cu/ZnSOD isozymes are indicated. *sod1*, MnSOD-deficient mutant; *sod1(pYSODpp)*, *sod1* bearing plasmid pYSODpp; *sod1(pEX2)*, *sod1* carrying plasmid pEX2; cured, *sod1(pYSODpp)* cured of plasmid by successive cycles of growth on nonselective medium; wt, isogenic wild-type strain.

Partial Purification and NH₂-Terminal Sequencing of the Processed Plant MnSOD from Yeast. From the analysis of the NH₂-terminal sequence of the mature MnSOD protein in *N. plumbaginifolia* and its corresponding cDNA, the precise position of mitochondrial processing in the plant could be assigned (5). A determination of the NH₂ terminus of the plant MnSOD as processed by the yeast machinery would thus permit a comparison of the specificity of the mitochondrial processing peptidase in each organism. For this, the protein was partially purified from total protein extracts derived from the MnSOD-deficient yeast mutant bearing plasmid pYSODpp. A substantial enrichment in the MnSOD was obtained by heating the sample to 60°C for 1 hr. The majority of proteins were precipitated by this treatment, while the MnSOD remained soluble and active (Fig. 5). Samples enriched for MnSOD were subsequently separated by NaDodSO₄/PAGE and electroblotted to polybase-coated glass-fiber sheets. The band corresponding to the MnSOD protein was cut out and analyzed by gas-phase sequencing (6). The amino acid sequence deduced from the HPLC traces shows the NH₂-terminal sequence of the mature MnSOD to be exactly the same as is found in the plant (Fig. 6) and, importantly, no ambiguity at the processing site could be detected. Thus, the yeast peptidase appears to cleave at this position both efficiently and specifically.

DISCUSSION

The complementation experiments presented here were designed to determine the extent to which a plant MnSOD could replace the SOD activities normally found in *E. coli* and yeast. In addition, this has allowed a comparison of mitochondrial import between plants and yeast.

The demonstrated ability of the plant MnSOD to complement the SOD-deficient *E. coli* mutant is not unexpected

since a structurally distinct Cu/ZnSOD from human can also partially complement this mutant (20). The plant MnSOD is able to complement the mutant to different degrees, depending on whether it is expressed as the preprotein or mature protein. The apparent abundance of preprotein enzyme activity in cell-free extracts contrasts with the low level (up to 70%) of complementation. This presumably indicates that the enzyme has a lower specific activity *in vivo* because of its

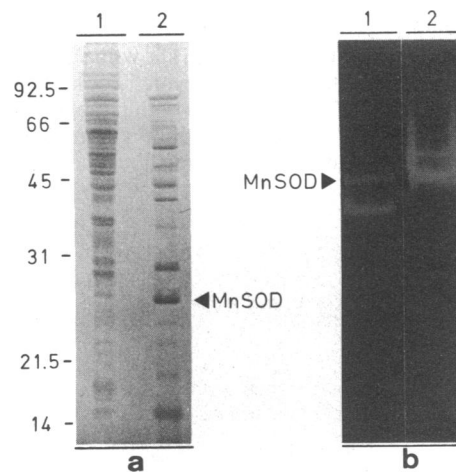

FIG. 5. Plant MnSOD produced in yeast. (a) Denaturing NaDodSO₄/15% polyacrylamide gel run according to Laemmli (16) and stained with Coomassie blue. Molecular size markers are shown in kDa; lane 1, total protein extract from *sod1* carrying pYSODpp grown in YPE; lane 2, heat-enriched protein extract. (b) Nondenaturing 10% polyacrylamide gel stained for SOD activity, showing retention of MnSOD activity after heat treatment. Lanes 1 and 2 are as in a. The position of MnSOD in both gels is indicated.

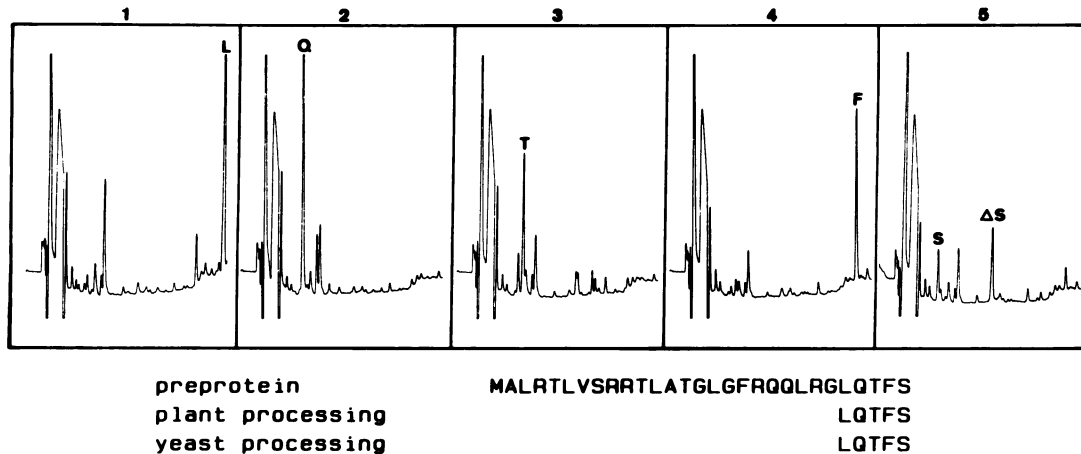

FIG. 6. NH₂-terminal amino acid sequence analysis of *N. plumbaginifolia* MnSOD as processed in the yeast *sod1* mutant. HPLC traces of the first five cycles are shown and the positions of the phenylthiohydantoin (PTH)-derivatized amino acids are indicated by the one-letter notation. Δ S denotes a dehydration product of PTH-serine observed in combination with PTH-serine in current automated gas-phase sequencing technology. The first 29 amino acids of the preprotein are shown below and the NH₂ terminus of the plant MnSOD after processing in plants and yeast is given.

NH₂-terminal extension. When this is removed, the enzyme can function as efficiently as the wild-type enzymes to protect against the oxidative stress caused by aerobic growth in minimal medium or the presence of paraquat or H₂O₂.

The transit peptide of the plant MnSOD possesses all the characteristics thought to be important for mitochondrial matrix-directing leader sequences (21). It is characterized by a lack of acidic residues and by five arginines dispersed among uncharged residues and the hydroxylated amino acids serine and threonine (Fig. 6). Our result showing the ability of the plant preprotein to completely restore the wild-type phenotype in the MnSOD-deficient mutant indicates that the yeast mitochondrial machinery can import and process the plant protein very efficiently. Analysis of the NH₂-terminal sequence of the processed enzyme showed unequivocally that the position of cleavage was identical to that used in *N. plumbaginifolia*. Moreover, no ambiguities could be detected at the processing site, indicating that, at least in this case, the specificity of the mitochondrial processing peptidase is highly conserved between plants and yeast.

Taken collectively, our results provide compelling evidence for the hypothesis that the mechanism of mitochondrial import that exists in yeast is also found in plants. The converse, however, remains to be proven. It is possible that the presence of chloroplasts within plant cells necessitates an additional level of discrimination not required for correct sorting of proteins in simpler eukaryotes. Transit peptides that guide proteins to the chloroplast share somewhat similar properties with those of mitochondria-destined proteins (see refs. 22 and 23), and, indeed, a chloroplast presequence can target reporter proteins to yeast mitochondria at a low efficiency (24). The experiments reported here demonstrate that it is possible to understand the mitochondrial protein translocation system operating in plants by making analogies with yeast systems. With this approach, any additional control mechanisms governing chloroplast and mitochondrial protein targeting in plants should then be revealed.

C.B. and T.A. contributed equally to this work and should each be considered as first authors. We thank Dr. A. Caplan, Dr. P. Dhaese, Dr. R. Contreras, and J. Demolder for interest and advice. We also thank Dr. Touati, Dr. van Loon, and Dr. Ernst for providing the *sodAsodB E. coli* mutant, the *sod1* yeast mutant, and the vector pEX2, respectively. The help of M. De Cock, K. Spruyt, S. Van Gijsegem, and V. Vermaercke in preparing the manuscript is greatly appreciated. This work was supported by grants from the "ASLK-Kankerfonds," the "Fonds voor Geneeskundig Wetenschappelijk

Onderzoek," and the Services of the Prime Minister. C.B. is supported by a Science and Engineering Research Council (NATO) predoctoral Overseas Studentship; T.A. is indebted to L'Air Liquide for financial support; M.V.d.B. and G.B. are bursars of the Instituut voor Wetenschappelijk Onderzoek in Nÿverheid en Landbouw (Belgium); and D.I. and J.V. are Senior Research Assistant and Research Associate of the National Fund for Scientific Research (Belgium), respectively.

- Halliwell, B. (1984) in *Chloroplast Metabolism: The Structure and Function of Chloroplasts in Green Leaf Cells*, ed. Halliwell, B. (Clarendon Press, Oxford, U.K.), pp. 180–206.
- Imlay, J. A. & Linn, S. (1988) *Science* **240**, 1302–1309.
- Bannister, J. V., Bannister, W. H. & Rotilio, G. (1987) *CRC Crit. Rev. Biochem.* **22**, 111–180.
- Parker, M. W. & Blake, C. C. F. (1988) *FEBS Lett.* **229**, 377–382.
- Bowler, C., Alliotte, T., De Loose, M., Van Montagu, M. & Inzé, D. (1989) *EMBO J.* **8**, 31–38.
- Bauw, G., De Loose, M., Inzé, D., Van Montagu, M. & Vandekerckhove, J. (1987) *Proc. Natl. Acad. Sci. USA* **84**, 4806–4810.
- Carlioz, A. & Touati, D. (1986) *EMBO J.* **5**, 623–630.
- van Loon, A. P. G. M., Pesold-Hurt, B. & Schatz, G. (1986) *Proc. Natl. Acad. Sci. USA* **83**, 3820–3824.
- Botterman, J. & Zabeau, M. (1987) *DNA* **6**, 583–591.
- Ernst, J. F. & Chan, R. K. (1985) *J. Bacteriol.* **163**, 8–14.
- Ito, H., Fukuda, Y., Murata, K. & Kimura, A. (1983) *J. Bacteriol.* **153**, 163–168.
- Koshland, D. & Botstein, D. (1980) *Cell* **20**, 749–760.
- Bradford, M. M. (1976) *Anal. Biochem.* **72**, 248–254.
- Beauchamp, C. & Fridovich, I. (1971) *Anal. Biochem.* **44**, 276–287.
- Beck, Y., Bartfeld, D., Yavin, Z., Levanon, A., Gorecki, M. & Hartman, J. R. (1988) *Bio/Technology* **6**, 930–935.
- Laemmli, U. K. (1970) *Nature (London)* **227**, 680–685.
- Dougherty, H. W., Sadowski, S. J. & Baker, E. E. (1978) *J. Biol. Chem.* **253**, 5220–5223.
- Goscini, S. A. & Fridovich, I. (1972) *Biochim. Biophys. Acta* **289**, 276–283.
- Ravindranath, D. S. & Fridovich, I. (1975) *J. Biol. Chem.* **250**, 6107–6112.
- Natvig, D. O., Imlay, K., Touati, D. & Hallewell, R. A. (1987) *J. Biol. Chem.* **262**, 14697–14701.
- Hurt, E. C. & van Loon, A. P. G. M. (1986) *Trends Biochem. Sci.* **11**, 204–207.
- Schmidt, G. W. & Mishkind, M. L. (1986) *Annu. Rev. Biochem.* **55**, 879–912.
- Karlin-Neumann, G. A. & Tobin, E. M. (1986) *EMBO J.* **5**, 9–13.
- Hurt, E. C., Soltanifar, N., Goldschmidt-Clermont, M., Rochaix, J.-D. & Schatz, G. (1986) *EMBO J.* **5**, 1343–1350.