

The influence of femoral head shift on hip biomechanics: additional parameters accounted

Marinko Erceg

Received: 11 February 2008 / Revised: 19 February 2008 / Accepted: 22 February 2008 / Published online: 15 April 2008
© Springer-Verlag 2008

Abstract Pauwels' method of hip biomechanics can explain a negative influence of the lateral shift of the femoral head on the load of dislocated hip joint, but, the influence of the cranial shift of femoral head can not be explained. A calculation of hip balance which takes into consideration both lateral and cranial shifts of the femoral head is presented. Two pelvic radiographs were used; of an adult person and of a two year old child. One hip was normal, and other was dislocated. Force R was established using horizontal lever k_1 , and a new vertical lever k_2 . Graphically and mathematically the results show that the force R is always greater in the dislocated hip. Both lateral and cranial shifts contribute to this. The modification of Pauwels method described clearly demonstrates that not only lateral but also cranial shift of the femoral head in dislocated hip should be taken into consideration.

Résumé La biomécanique de la hanche selon Pauwels peut expliquer les effets négatifs de la charge sur une hanche luxée à la partie latérale de la tête fémorale mais, n'explique pas les effets sur la partie craniale. Ce travail a utilisé une analyse à partir de la balance de Pauwels prenant en compte ces effets à la fois latéraux et craniaux sur la tête

fémorale. Deux radiographies du bassin ont été utilisées, un bassin d'adulte et un bassin d'enfant âgé de deux ans. Une hanche étant normale et l'autre luxée. La force R est déterminée en utilisant le niveau horizontal $K1$ et un nouveau niveau vertical $K2$. Sur le plan graphique et mathématique, les résultats montrent que la force R est toujours plus importante sur la hanche luxée, les changements portant sur la partie latérale et la partie craniale contribuent à cet effet délétère. La description des modifications de la balance de Pauwels démontre que non seulement la partie latérale mais aussi la partie craniale de la tête fémorale doivent être prises en considération lorsqu'une hanche est luxée.

Introduction

When standing on both feet, the body weight (above the hip level) is evenly distributed on both hip joints. That is around $2/3$ of the total body weight (G) which, when equally divided between both hips, is around $1/3$ of the body weight per joint, and the force is vertical. This changes when force is concentrated on one hip only, for example when walking. The pelvis tends to 'fall' towards the nonweight bearing side, but this is prevented by the action of abductor muscles (pelvitrochanetric musculature) whose action keeps the pelvis in a horizontal position. Pauwels compared this by a balance of horizontal levers k_1 and k_2 whose position is influenced by the body weight G and muscle force F .

Lever k_1 represents the distance between the centre of the hip and the gravity centre (force G acts through this point). This distance crosses the midline of the body if a leg

M. Erceg
Department of Orthopedics,
University of Split School of Medicine,
Split, Croatia

M. Erceg (✉)
R. Boškovića 12,
21000 Split, Croatia
e-mail: marinko.erceg1@st.t-com.hr

is raised, because the raised leg ‘drags’ the point of gravity to its side and that point is located at the obturator foramen line.

Lever k_2 represents the horizontal distance between the centre of the hip and the tip of the greater trochanter (force F acts from this point). In adults, the tip of the greater trochanter is at the same level as the centre of the hip joint. The equilibrium of forces on both sides of the hip joint is expressed as $k_1 \cdot G = k_2 \cdot F$. In adults the lever k_1 is about three times longer than lever k_2 , hence the force F should be three times greater than the body weight G . Pawels concludes (Fig. 1) that the weight bearing on each hip of an adult is about four times greater than the body weight ($R \approx 4G$) [4]. It is assumed that the force R has 16° inclination in frontal plane in adults. This angle is defined by two lines, the vertical line passing through the point gravity (G) and the line passing through the tip of the greater trochanter following the direction of abductor muscles. Any lengthening of the k_1 (eg. the hip dislocation) has an adverse effect on the hip load and any lengthening of the k_2 (eg. coxa vara) has a beneficial effect on the hip load. If k_2 is shortened (coxa valga, children’s hips) the total hip load is increased and the force R is more vertical [4].

Numerous researchers also support this theory, but they believe that not only the gluteus medius and minimus but also the iliotibial band (ITB) and vastus lateralis-gluteus medius complex counterbalance the varus bending torque of the loads acting on the hip [2]. Kummer also agrees with Pauwels theory, with two conditions: the supporting foot must be positioned on the action line of the gravity force of the body, and the abduction forces on the hip are composed of forces of the lesser glutei (70%) and the muscles controlling the iliotibial tract (30%) [3].

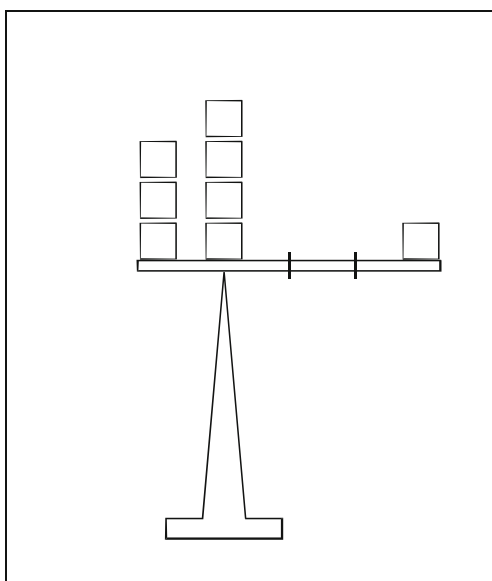

Fig. 1 Schematic demonstration of Pauwels' method of hip biomechanics

However, hip dislocation is not only associated with the lateral femoral head shift, but there is also a significant cranial femoral head shift. Pauwels' method does not take cranial shift into consideration, it only considers horizontal parameters. It seems reasonable that Pauwels' method needs to be modified to also take cranial femoral head shift into consideration.

Materials and methods

Two pelvic radiographs were used, one of an adult (the tip of the greater trochanter horizontally correlated with the centre of the femoral head) and the other of a 2-year-old child. On both radiographs the left hip joint was dislocated and the right was normal. After drawing X-rays, Pauwels' method was used to construct the force R using the lever k_1 and the force G (the body weight).

According to Pauwels, the force R in adults has 16° inclination (angle γ). One line extends from the centre of the femoral head with 16° inclination and the other line is from the point G . From the point where these lines cross, a third line runs on the top of the great trochanter (muscle force direction F).

As the next step, a vertical lever k_2 was constructed. The idea was taken from the work of Strange [5], who suggested the idea but never postulated its influence on the total hip load. The vertical line was drawn from the centre of the hip joint. The point of crossing of the above two lines was marked as the point A . It was assumed that this point is the proximal attachment of pelvitrochanteric musculature and represents the upper boundary of the vertical lever k_2 along which the force of abductors is conveyed (Fig. 2).

In this model, the muscle force F_m acting from the point A on the vertical lever k_2 (at an angle α) keeps the balance of the momentum of the body weight ($(k_1 \cdot G)$).

$$F_m \cdot \sin \alpha \cdot k_2 = k_1 \cdot G$$

$$\text{or}$$

$$F_m = \frac{k_1 \cdot G}{k_2 \cdot \sin \alpha}$$

The force F_m is estimated graphically by firstly calculating the force F_{mx} (component of the force F_m along the x axis) which is perpendicular to the lever k_2 .

$$k_1 \cdot G = k_2 \cdot F_{mx}$$

This is followed by:

$$F_{mx} = \frac{k_1 \cdot G}{k_2}$$

When the force F_{mx} is mathematically determined, the force F_m is determined graphically by drawing the vertical line from the top of force F_{mx} to the line starting at point A

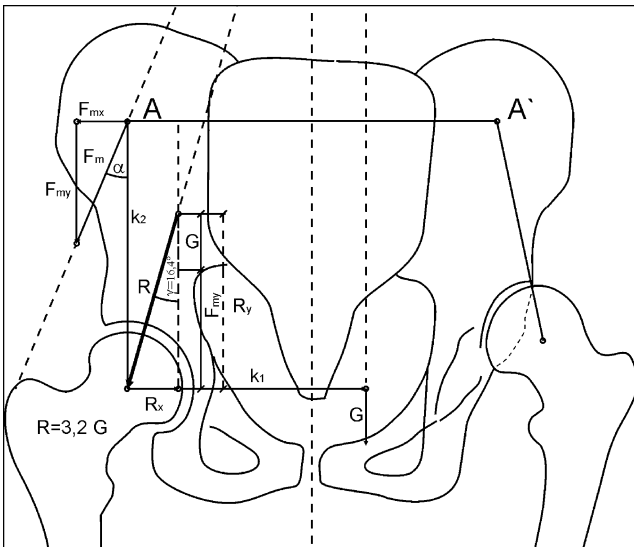

Fig. 2 Demonstration of establishing force **R** on a normal adult hip using the newly established vertical lever **k₂**

(origin of the force **F_{mx}**) and finishing on the tip of the greater trochanter (the direction of the muscle force).

The muscle force depends not only on the size of the lever **k₁** and on the body weight but also on the size of the vertical lever **k₂**, and on the size of the angle α . This angle is determined not only by the varus and valgus position of the upper femoral end but also by the size of the vertical lever **k₂**. Using forces **G** and **F_m** a parallelogram defining the force **R** of the normal hip is constructed. Its value is **3.2G**.

From this calculation the following is derived:

$$F_{mx} = R_x \text{ and } R_y = F_{my} + G.$$

In order to reach the balance in the hip joint, the sum of all forces acting along the *x* axis should be zero ($\Sigma x=0$); the sum of all forces acting along the *y* axis should be zero ($\Sigma y=0$), and the sum of all force moments should be zero ($\Sigma M=0$).

$$\Sigma x = 0 \quad F_m \cdot \sin \alpha = R_x = R \cdot \sin \gamma \tag{1}$$

$$\Sigma y = 0 \quad F_m \cdot \cos \alpha + G = R_y = R \cdot \cos \gamma \tag{2}$$

$$\Sigma M = 0 \quad F_m \cdot \sin \alpha \cdot k_2 = G \cdot k_1 \tag{3}$$

This means that when in balance each force acting on the hip joint should be opposed by an equal force in the opposite direction.

Then the following formula can be derived:

$$R = \frac{G \cdot k_1}{k_2 \cdot \sin \gamma}$$

This formula highlights that force **R** (total hip load) also depends on the lever **k₂**, i.e. the longer the lever the smaller the hip load [5].

Using this approach the force **R** was determined on the normal side of an adult hip.

Thus, the biomechanics of a dislocated adult hip joint was determined. Because the hip dislocation does not affect the proximal attachment of the pelvitrochanteric muscle, the point **A** was copied from the normal side to the dislocated side and point **A'** was determined. Horizontal lever **k'₁** was determined as on the normal hip side by connecting the centre of the femoral head with the line vertical to the obturator foramen on the opposite side. The vertical lever was determined by connecting the point **A'** with the centre of the dislocated femoral head. This lever was not exactly perpendicular to the lever **k'₁** and was named **k''₂**. From point **A'** a perpendicular line to the lever **k''₂** was constructed and force **F'mε** was calculated. After connecting point **A'** and the greater trochanter (abductor muscles direction) the perpendicular line from the tip of **F'mε** was drawn. This is how the force **F'm** was constructed. This force was disassembled to its components **F'mx** and **F'my** (Fig. 3).

Taking into consideration that **R'x = F'mx** and **R'y = F'my + G**, construction of the force **R'** on a dislocated hip was made and compared with force **R** on the normal side.

From Fig. 3 it appears that the oblique lever of the dislocated hip **k''₂** becomes much smaller when shifted into the perpendicular position **k'₂**.

The forces **R** and **R'** were then determined on a 2-year-old child with normal and dislocated hips (Figs. 4 and 5). In children's hips the tip of the greater trochanter does not horizontally project to the femoral head centre because of a normally increased valgus position. It projects more distally. Hence the lateral lever **k₂** appears to be more than three time smaller than lever **k₁**, and the force **R** on the child's hip has

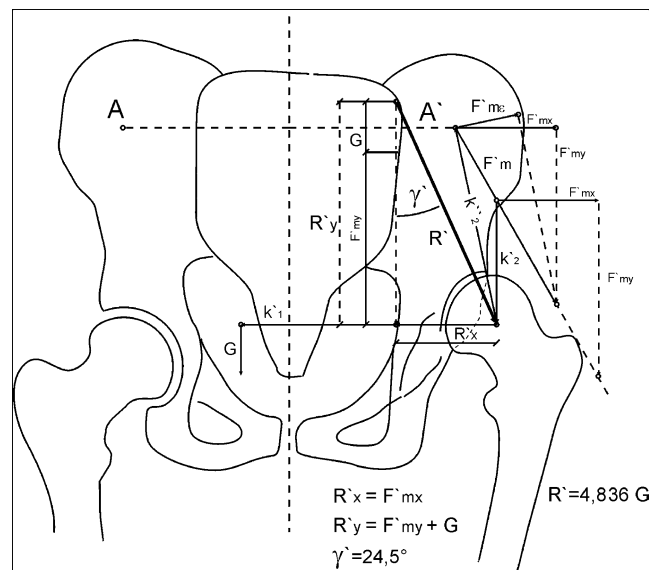
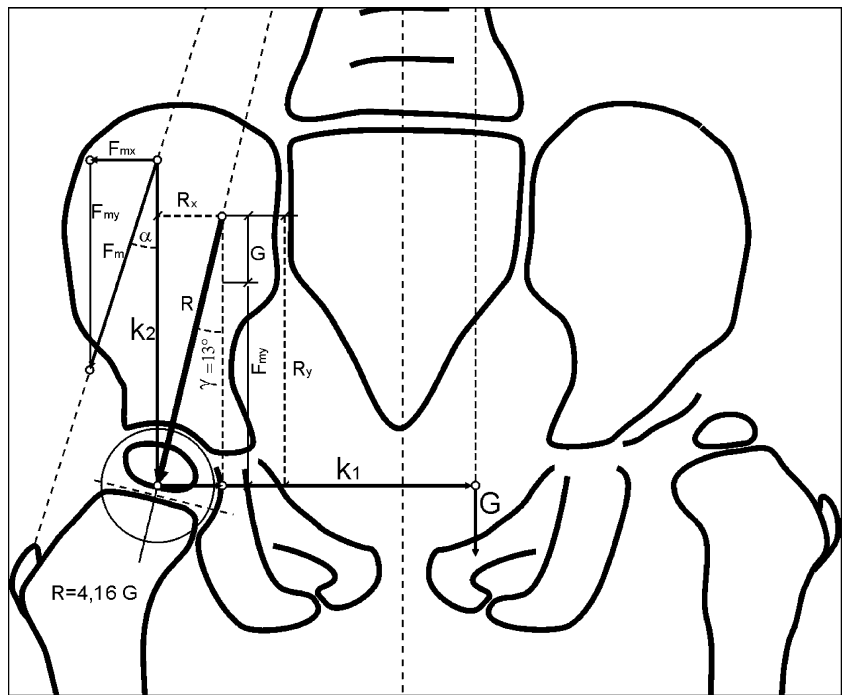

Fig. 3 Demonstration of establishing force **R'** on dislocated hip of an adult

Fig. 4 Demonstration of establishing force **R** on normal child hip



to be relatively greater and more vertical. Consequently the angle γ has to be smaller than 16° . Using Pauwels' explanation that the force **R** on a child's hip projects perpendicular to the upper epiphyseal cartilage, the crossing of forces **R** and **G** was determined. From this point the line projecting to the tip of the greater trochanter was constructed and the vertical lever k_2 was defined. Knowing the values of the horizontal lever k_1 , vertical lever k_2 , and the body weight **G**, the force **Fmx** can be calculated and force **Fm** can be determined.

Here the following also applies: $F_{mx} = R_x$ and $R_y = F_{my} + G$, and the force **R** can be constructed on the normal side. The force **R'** on a dislocated hip is determined as in an adult dislocated hip.

When analysing construction of force **R** on both normal and **R'** on both dislocated hips the following appears to be the case:

1. The value of the force **Fmx** (component of force **Fm** along the *x* axis) is the same as **Rx** (component of force

Fig. 5 Demonstration of establishing force **R'** on dislocated child hip

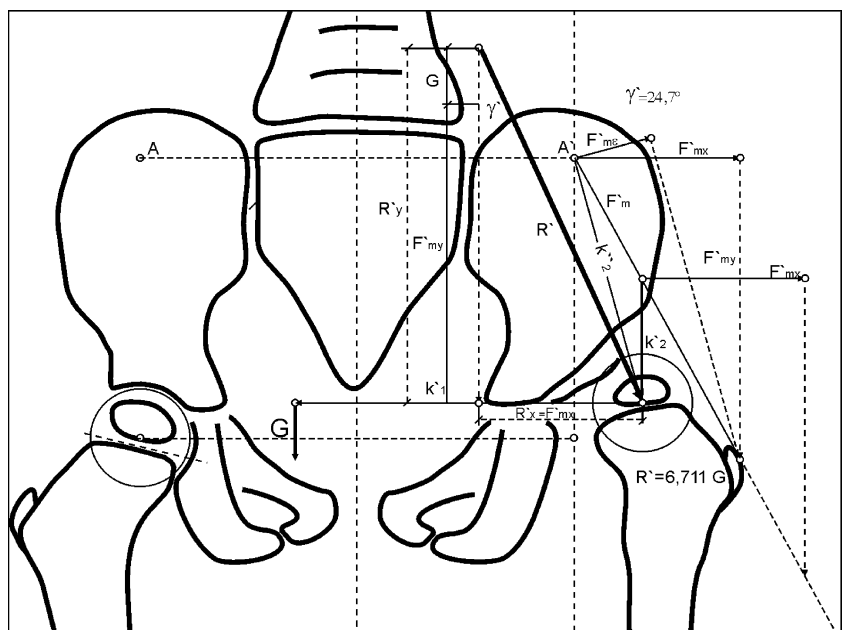

R along the *x* axis), and that component of the force is greater when the vertical lever **k**₂ is smaller (which happens in hip dislocation).

So, **F**_{*mx*} = **R**_{*x*}, and this is inversely proportional to the size of the vertical **k**₂, because $F_{mx} = \frac{k_1 \cdot G}{k_2}$. So the force **F**_{*mx*} depends on the size of the horizontal lever **k**₁ and vertical lever **k**₂ as well as on the value of angle α . With the same value of the CCD angle, the force **F**_{*mx*} is greater when the lever **k**₂ is smaller (Fig. 6) [1, 5].

2. The value of **R**_{*y*} (component of force **R** along the *y* axis) is the same as the value of the force **F**_{*my*} (component of force **F**_{*m*} along the *y* axis), increased by the body weight (**G**). So **R**_{*y*} = **F**_{*my*} + **G**. Force **F**_{*my*} is greater when the vertical lever **k**₂ is smaller (Fig. 6).
3. In dislocated hips there is always both lateral and cranial shift of the femoral head from the acetabulum, so there is an increase of the horizontal lever **k**₁ and a decrease of the vertical lever **k**₂ which leads to the increase of force **R**' meaning an increased load on the dislocated hip.
4. The value of force **R** on the normal adult hip is 3.2**G**, which is smaller than 4**G** which was established by Pauwels. The force **R**' of the dislocated adult hip of the same pelvis is 4.83**G**, corresponding to a 50% increase (Figs. 2 and 3).

The value of force **R** of the normal child's hip is 4.16**G**, which is higher than the force **R** of the adult hip. Force

R' of the dislocated child's hip is 6.7**G** which is a 61% increase (Figs. 4 and 5).

When forces **R** of a normal adult and child's hip are compared with forces **R**' of a dislocated adult and child's hip, it appears that values of **R**' are much higher than if they had been calculated using an increase of horizontal lever **k**'₁ on the dislocated side. In adults the horizontal lever **k**'₁ on the dislocated hip increased 17% and force **R**' increased 50%. In the child's hips the horizontal lever **k**'₁ on the dislocated hip increased 25% and force **R**' increased 61%.

This highlights the importance of taking cranial femoral shift into consideration.

5. Forces **R** and **R**' can be calculated using not only graphic but also mathematical methods by applying the following formula:

$$R = \frac{G \cdot k_1}{k_2 \cdot \sin \gamma}$$

Regardless of the approach the results are always identical—graphically and mathematically.

Discussion

In hip dislocation both lateral and cranial shifts of the femoral head from the acetabulum can be observed. Pauwels' method can explain effects of the lateral shift while cranial shift was never mentioned and/or taken into consideration. The method presented here takes both shifts into consideration and explains their negative consequences on the biomechanical properties of the hip. All important parameters are taken into consideration using this approach:

$$F_m \cdot \sin \alpha \cdot k_2 = k_2 \cdot G$$

and finally

$$R = \frac{G \cdot k_1}{k_2 \cdot \sin \gamma} \text{ or } R' = \frac{G \cdot k'_1}{k'_2 \cdot \sin \gamma'}$$

This formula explains not only that the dislocated hip has to sustain greater load than the normal side but also gives the reason for that. The balance described is only theoretical but helps to estimate required muscular strength to gain this balance. In hip dislocation there is relative insufficiency of hip abductors manifested by limping (positive Trendelenburg and Duchenne's signs).

This approach could also be useful in understanding the influence of cranialisation of the hip on its biomechanical properties in case of hip arthroplasty when the acetabulum is implanted more laterally and/or cranially from its normal position. This work should encourage more research in this field with the aim of finding better technical solutions in constructing and implanting hip prosthetic devices to make hip arthroplasty of dislocated hips more biomechanically advantageous.

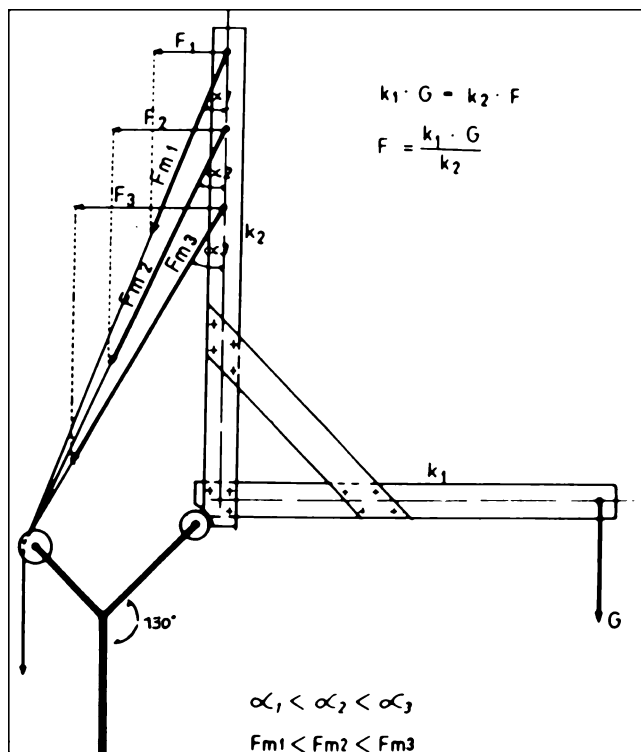

Fig. 6 The longer the vertical lever, the smaller the muscle force for hip balancing

References

1. Erceg M (2006) Ortopedija. Medicinski fakultet, Split, pp 290–294
2. Fetto J, Leall A, Moroz A (2002) Evaluation of the Koch model of the biomechanics of the hip: clinical perspective. *J Orthop Sci* 7 (6):724–730
3. Kummer B (1993) Is the Pauwels theory of hip biomechanics still valid? A critical analysis, based on modern methods. *Ann Anat* 175 (3):203–210
4. Pauwels F (1980) *Biomechanics of the locomotor apparatus*. Springer, New York, pp 1–228
5. St Clair Strange FG (1965) *The hip*. William Heinemann Medical Books Limited, London, pp 25–35