

Phenotypic Expression of Heterozygous Lipoprotein Lipase Deficiency in the Extended Pedigree of a Proband Homozygous for a Missense Mutation

Dana E. Wilson,^{*1} Mitsuru Emi,^{‡§} Per-Henrik Iverius,^{*1} Akira Hata,^{‡§} Lily L. Wu,^{||} Elaine Hillas,^{‡§} Roger R. Williams,^{*||} and Jean-Marc Lalouel^{‡§}

^{*}Department of Internal Medicine, [‡]Department of Human Genetics, [§]Howard Hughes Medical Institute, and ^{||}Cardiovascular Genetics Research Clinic, University of Utah Health Sciences Center, Salt Lake City, Utah 84132; and ¹the Veterans Affairs Medical Center, Salt Lake City, Utah 84148

Abstract

Familial lipoprotein lipase (LPL) deficiency is a rare genetic disorder accompanied by well-characterized manifestations. The phenotypic expression of heterozygous LPL deficiency has not been so clearly defined. We studied the pedigree of a proband known to be homozygous for a mutation resulting in nonfunctional LPL. Hybridization of DNA from 126 members with allele-specific probes detected 29 carriers of the mutant allele. Adipose tissue LPL activity, measured previously, was reduced by 50% in carriers, but did not reliably distinguish them from noncarriers. Carriers were prone to the expression of a form of familial hypertriglyceridemia characterized by increased plasma triglyceride, VLDL cholesterol and apolipoprotein B, and decreased LDL and HDL cholesterol concentrations. These manifestations were age modulated, with conspicuous differences between carriers and noncarriers observed only after age 40. Several noncarriers exhibited similar lipid abnormalities, but without the inverse relationship between VLDL cholesterol and LDL cholesterol noted among carriers. In addition to age and carrier status, the potentially reversible conditions, obesity, hyperinsulinemia and lipid-raising drug use were contributory. Thus heterozygous lipoprotein lipase deficiency, together with age-related influences, may account for a form of familial hypertriglyceridemia. (*J. Clin. Invest.* 1990. 86:735-750.) Key words: lipoprotein lipase • chylomicron • genetics • VLDL • HDL

Introduction

Familial hyperchylomicronemia (type I hyperlipoproteinemia) is a rare inherited disease due to complete or near-complete deficiency of lipoprotein lipase (LPL),¹ a triglyceride hydrolase responsible for the processing of the triglyceride-rich lipoproteins, chylomicrons, and VLDLs. Affected subjects classically present in infancy with fat intolerance, episodic ab-

dominal pain with or without documented pancreatitis, eruptive xanthomatosis, severe hypertriglyceridemia, and fasting hyperchylomicronemia (1-3). A clinically similar disorder occurs with inherited deficiency of the LPL cofactor, apo C-II (1, 4).

The inheritance of familial hyperchylomicronemia is characterized by the absence of vertical transmission, multiple affected siblings, frequent consanguinity, and reduced LPL activities in parents (1-8). These findings imply that LPL-deficient probands are often homozygous for a mutant LPL allele. Relatives of reported probands have had variable lipoprotein patterns. Parents have had either increased VLDL alone or entirely normal lipids and lipoproteins (1). Other family members suspected of being heterozygous for a mutant LPL allele have been described with chylomicronemia and increased VLDL (type V), increased VLDL alone (type IV), increased LDL (type IIA), or increased VLDL and LDL (type IIB) (7, 9, 10). Reduced HDL cholesterol concentrations have been observed regularly among hypertriglyceridemic relatives. These observations led to the suggestion (6, 7) that the phenotype resulting from the carrier genotype is familial combined hyperlipidemia (11).

Heterozygotes for LPL deficiency have escaped unambiguous identification. In obligate carriers mean adipose tissue LPL activities are reduced ~ 50% (5), but individual measurements overlap with normal (7). Suspected carriers likewise may have reduced or normal postheparin plasma LPL activities by selective assay (1). Babirak and co-workers (6) assayed immunoreactive LPL (12-14) along with postheparin plasma LPL activity to identify nonobligate carriers in small kindreds.

We previously described a patient with classical LPL deficiency (type I) along with data from 47 relatives in her large nonconsanguineous pedigree (7). When she was first studied at age 19, postheparin plasma and adipose tissue LPL activities were at the limits of detection. Apo C-II was present on polyacrylamide gel electrophoresis and normal LPL cofactor activity was detected (7). Plasma lipids and lipoproteins were entirely normal in the proband's father and the paternal lineage. Her mother had Type IV hyperlipoproteinemia, and some members of the maternal lineage exhibited hypertriglyceridemia, intermittent fasting chylomicronemia, elevated VLDL cholesterol, and/or decreased HDL cholesterol concentrations. Three individuals in the pedigree had calculated LDL cholesterol concentrations that exceeded 95th percentile age- and sex-specific cutoffs. Whether the multiple lipoprotein patterns observed in relatives of the proband resulted from heterozygous LPL deficiency or from the fortuitous, independent occurrence of a distinct familial condition could not be resolved in the absence of specific genetic markers.

Determination of the cDNA sequence for the normal human enzyme (15) and the structure of the human gene (16)

Dr. Emi's present address is Department of Bioscience, National Cardiovascular Center Research Institute, Fujishiro-dai 5, Suita, Japan 565.

Address reprint requests to Dr. Dana E. Wilson, Endocrinology Section (111E), Veterans Administration Medical Center, 500 Foothill Boulevard, Salt Lake City, UT 84148.

Received for publication 6 February 1990 and in revised form 4 May 1990.

1. Abbreviations used in this paper: FCR, fractional catabolic rate; LPL, lipoprotein lipase.

The Journal of Clinical Investigation, Inc.
Volume 86, September 1990, 735-750

opened the way for genetic characterization of probands with clinical LPL deficiency (16–18). By cloning and sequencing cDNA prepared from adipose tissue total RNA isolated in the proband, we have found that she was homozygous for a single point mutation (GGG→GAG) at position 818 of the LPL cDNA leading to a glycine-to-glutamic acid substitution at residue 188 of the mature enzyme (18). Furthermore, *in vitro* expression of the mutant gene resulted in the production of immunoreactive but functionally defective LPL (18). Profound deficiency of postheparin plasma LPL activity in the proband (7) was confirmed independently, and immunoreactive material was detected in postheparin plasma with a specific ELISA.

Knowing the molecular defect in the proband in the present study, it became possible to determine directly the carrier status of family members with respect to this mutation and to investigate phenotypic expression of the mutation in the heterozygous state.

Methods

Experimental subjects. K2003 is nonconsanguineous, Caucasian, and of mostly Northern European descent. Both of the proband's grandfathers died before age 65 with a history of heart disease. The maternal grandmother died at 82 of unknown causes. The paternal grandmother, 81 yr old at the time of our previous study, died in the interim. The proband's father has developed non-insulin-dependent diabetes mellitus. He received a pacemaker for cardiac arrhythmia in 1989 but he did not have significant coronary artery disease by angiography.

Most of the 47 family members originally ascertained between 1978 and 1981 consented to be restudied. Additional subjects from the extended pedigree, including spouses, were recruited randomly in the absence of information about their lipid or lipoprotein profiles, and initially without knowledge of parental or sibling carrier status. Later, as the carrier status of members of the pedigree became known, the offspring of carriers were actively recruited. In toto, 126 subjects were sampled, excluding the index patient. All subjects completed a targeted questionnaire, had body height, weight, and blood pressure measured, and gave informed consent according to institutional guidelines.

Laboratory analyses. Venous blood samples were collected after subjects had fasted 12–15 h according to Lipid Research Clinic guidelines (19). Plasma lipids were characterized by a microprocedure described elsewhere (20). The VLDL were separated from other lipoproteins by room temperature ultracentrifugation of 200 μ l of plasma for 4 h at 60,000 rpm in a tabletop centrifuge (model TL-100; Beckman Instruments, Fullerton, CA). Cholesterol in the HDL fraction was measured after MgCl₂-dextran sulfate precipitation (21). LDL cholesterol was calculated as the difference between cholesterol in the ultracentrifugal bottom fraction and measured HDL cholesterol.

Uric acid, glucose, urea nitrogen, total bilirubin, albumin, calcium, total protein, phosphorous, creatinine, and electrolyte concentrations, and aspartate aminotransferase, lactate dehydrogenase, and γ -glutamyltransferase activities were determined with Baker reagents on an autoanalyzer (Encore II; Baker Instruments, Allentown, PA). Serum insulin was measured by RIA (Cambridge Medical Diagnostics, Billerica, MA). Adipose tissue lipoprotein lipase activities were assayed in 1981 as described in our published report (7).

Genomic DNA amplification and dot-blot hybridization. Two synthetic primers, LP790 (5'-GTAGACGTCTTACACACA-3') and RLP828 (5'-TGGATTCCAATGCTTCGA-3') were used to amplify enzymatically a 56-bp region (nucleotides 790–845) of the LPL gene. A reaction mixture containing 1 μ g of genomic DNA was denatured at 95°C for 1 min, primer annealed at 60°C for 30 s, and extended at 72°C for 1 min for a total of 30 cycles. Cloned M13 DNA samples containing the normal and mutant LPL sequences were treated identically and used as controls for hybridization in every run. Amplified

DNA (10 ng) was spotted on nylon membranes and hybridized with ³²P-end-labeled oligonucleotide probes (818G, 5'-CCAGGGACCTCTGGTGA-3' or 818A, 5'-TCACCAGAGAGTCCCTGG-3') corresponding respectively to normal and mutant sequences. The membranes were washed at 62°C and autoradiographed (18).

Data analysis. Statistical analyses were carried out using standard methods (22, 23). Raw data were age- and sex-adjusted (11) when appropriate to male age 40–44 values, using data from Visit 2 in the Lipid Research Clinics tables (24). The Mann-Whitney U test was used to compare independent two-sample cases and Kendall's rank correlation, τ , was used for correlation analysis unless skewed data were first normalized by log-transformation so that parametric correlations could be carried out. One insulin-treated diabetic noncarrier (no. 415) with a measured serum insulin value of 253 μ U/ml, presumed to be the result of interfering antiinsulin antibodies, was excluded from comparisons that included serum insulin concentration. Multiple linear regression and discriminant analyses were carried out with SPSS/PC+ statistical software (SPSS Inc., Chicago, IL).

Results

126 subjects were studied, 76 females and 50 males (Fig. 1 and Appendix). 29 heterozygous carriers were detected unambiguously by dot-blot hybridization using allele-specific oligonucleotide probes, with mutant and wild-type sequence controls in every test (18). Females were overrepresented proportionately among both carriers and noncarriers, ostensibly because inflexible employment schedules hindered recruitment of males.

Plasma lipids, lipoproteins, and apolipoproteins. In carriers, triglyceride concentrations were skewed toward higher values (Fig. 2) and were significantly increased compared to non-carriers (Table I, all subjects). Carriers also had increased VLDL cholesterol and tended to have higher total plasma apoB concentrations ($P = 0.062$). This reflected an increase in VLDL-associated apoB since there was a significant positive correlation of total apoB with VLDL cholesterol ($P = 0.0001$ by Mann-Whitney; $r = 0.659$ by parametric analysis) but not with LDL cholesterol. HDL cholesterol concentrations were skewed toward lower values in carriers (Fig. 3) and were significantly decreased. ApoA-I concentrations however did not differ significantly between the two groups so the HDL cholesterol/apoA-I ratio tended to be lower in carriers ($P = 0.062$).

Effect of age on plasma lipids and lipoproteins. The relationship between genotype, age, and log-normalized plasma triglyceride concentration was examined since the expression of familial hypertriglyceridemia is often delayed until middle age (25). As observed by others (24, 26), triglyceride concentrations rose with age both in noncarriers and carriers (Fig. 4) as did VLDL cholesterol (data not shown). Before age 40 there were no statistically significant differences in lipid, lipoprotein, or apolipoprotein concentrations between normals and carriers (Table I). In contrast, individuals age 40 and older with heterozygous LPL deficiency had significantly increased plasma triglyceride, VLDL cholesterol and apoB concentrations, and decreased HDL cholesterol concentrations. The ratio, HDL cholesterol/apoA-I, was reduced in older carriers ($P = 0.036$), consistent with relative triglyceride enrichment of HDL without a change in particle number.

The age dependency of phenotypic expression was tested rigorously using log-transformed-dependent variables. After ruling out an independent interaction between age and sex by analysis of noncarriers only (data not shown), a correlation matrix between dependent and predictor variables was gener-

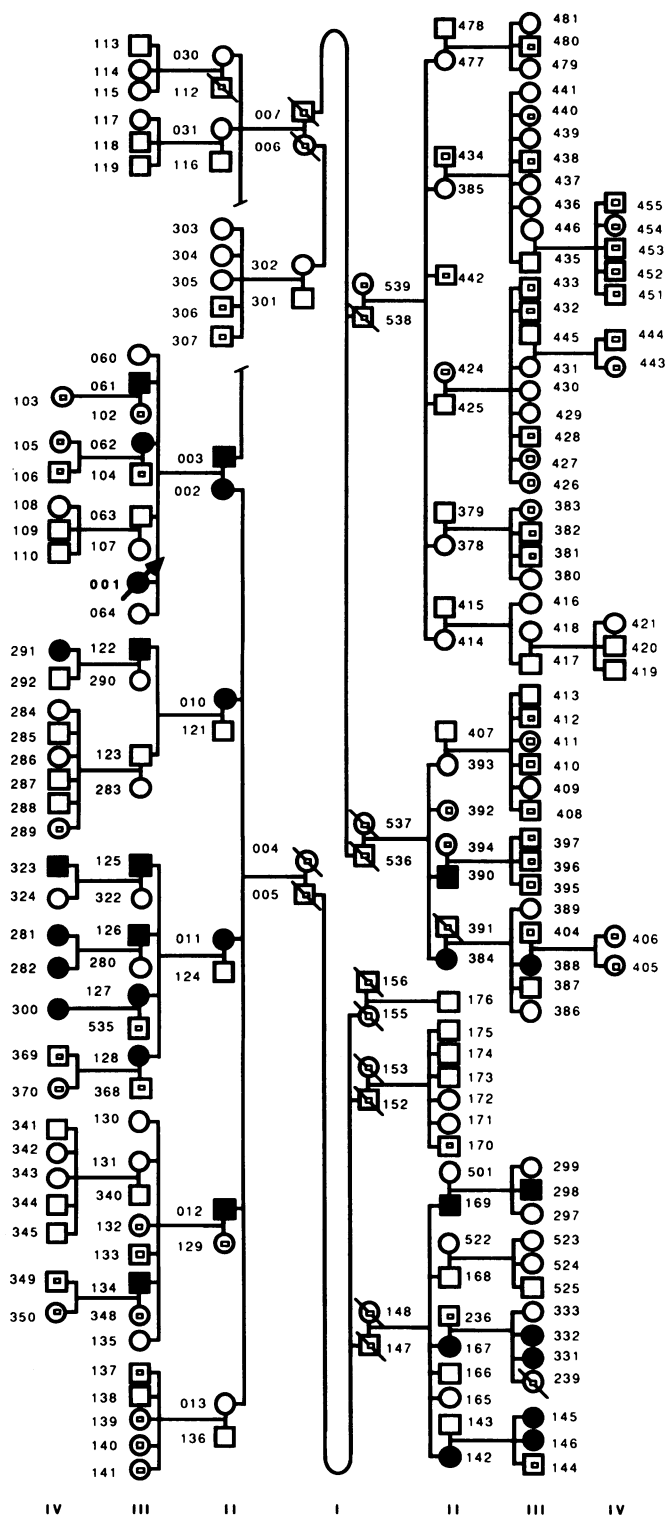

Figure 1. Kindred 2003. The proband (001) is indicated by an arrow. ●, subject proven to be a carrier with allele-specific oligonucleotide probes; ○, noncarrier; ⊙, living subject, not studied; ☒, deceased subject, not studied.

ated using data from all subjects (Table II). As expected, strongly significant positive correlations were seen between age and ln (triglyceride), ln (VLDL cholesterol), ln (LDL cholesterol), and ln (apolipoprotein B).

A multivariate linear model was then used to test the contributions of age, sex, carrier status, age-carrier status (the product of age and coded carrier status), and other candidate variables. This analysis showed an independent contribution of age-carrier status to VLDL concentration, reflected by significant positive correlations with ln (triglyceride), ln (VLDL cholesterol), and ln (apolipoprotein B), as well as a negative correlation with HDL cholesterol but not apoA-I concentrations (Table III). The highly significant correlations observed between age-carrier status and the dependent variables confirmed the potentiating effect of age on expression of the mutant allele.

LDL cholesterol in carriers. If heterozygous LPL deficiency were expressed in the pedigree as familial combined hyperlipidemia (6, 7), LDL cholesterol concentrations ought to be significantly elevated in some proven carriers. However, no significant correlation between carrier status and LDL cholesterol was observed in the multivariate analysis (Table III). In fact, LDL cholesterol was significantly lower in carriers than in non-carriers after the age of 40 (Table I; $P = 0.009$). In our previous report (7) three individuals had LDL cholesterol concentrations that exceeded age- and sex-specific 95th percentile cutpoints. The first (numbered III-10 in reference 7, current pedigree 133) with an LDL cholesterol of 202 mg/dl in 1979 and a 50% likelihood of carrying the mutation, could not be restudied. This individual may have inherited hypercholesterolemia from his mother, a noncarrier spouse unrelated to the

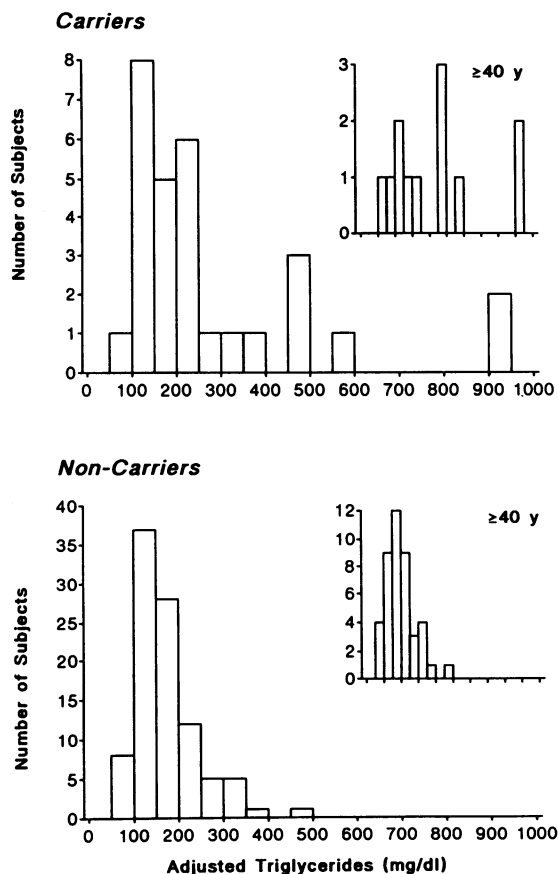

Figure 2. Histograms of age- and sex-adjusted (11, 35) plasma triglyceride concentration in carriers ($n = 97$) and noncarriers ($n = 29$). (Inset) Subjects age 40 or older.

Table I. Age- and Sex-adjusted Lipid and Lipoprotein Variables in Carriers and Noncarriers Stratified by Age

	Noncarriers		Carriers		P value*
	Mean	SD	Mean	SD	
All subjects (n = 126)	n = 96		n = 29		
Triglyceride	169	73	282	41	0.005
Total cholesterol	211	31	224	45	—
VLDL cholesterol	33.5	17.0	55.7	39.8	0.007
LDL cholesterol	139	28	130	39	—
HDL cholesterol	36.9	10.9	31.1	11.8	0.02
Apolipoprotein B	72.0	21.0	82.0	28.6	0.06
Apolipoprotein A-I	131	24	126	21	—
TG/VLDL cholesterol	5.2	1.2	5.3	1.1	—
HDL cholesterol/ApoA-I	.285	.088	.248	.089	0.06
LDL/HDL cholesterol	4.14	1.61	4.80	2.29	—
Age < 40 yr (n = 71)	n = 54		n = 17		
Triglyceride	149	50	170	66	—
Total cholesterol	209	27	212	27	—
VLDL cholesterol	28.0	10.1	31.8	10.2	—
LDL cholesterol	141	25	145	30	—
HDL cholesterol	37.7	9.3	34.5	10.3	—
Apolipoprotein B	62.4	16.1	66.9	12.8	—
Apolipoprotein A-I	132	24	122	18	—
TG/VLDL cholesterol	5.4	0.9	5.4	0.8	—
HDL cholesterol/ApoA-I	.288	.066	.280	.075	—
LDL/HDL cholesterol	4.00	1.28	4.56	1.49	—
Age ≥ 40 yr (n = 55)	n = 42		n = 12		
Triglyceride	195	88	441	267	0.0003
Total cholesterol	213	37	240	61	—
VLDL cholesterol	40.5	21.0	89.6	41.7	0.0003
LDL cholesterol	136	31	110	42	0.009
HDL cholesterol	35.8	12.6	26.3	12.7	0.04
Apolipoprotein B	84.4	20.2	103	31.6	0.03
Apolipoprotein A-I	130	26	131	24	—
TG/VLDL cholesterol	5.1	1.3	5.0	1.6	—
HDL cholesterol/ApoA-I	.281	.111	.202	.090	0.04
LDL/HDL cholesterol	4.32	1.95	5.28	3.11	—

Lipid and lipoprotein variables were normalized to male sex at age 40 by adding or subtracting age- and sex-specific differences taken from the Lipid Research Clinics database (24). Concentrations are expressed in milligrams/deciliter. * Significance levels for differences in means between the two groups were obtained by the Mann-Whitney U test corrected for ties.

proband, whose total cholesterol was 256 and calculated LDL was 163 mg/dl. The second (III-5, 125) a proven carrier, had an LDL cholesterol of 172 mg/dl (75–90th percentile) on retesting. The third (III-22, 138), with an LDL cholesterol of 137 mg/dl when first seen at age 12, proved to be a noncarrier. Although in the present study, two normotriglyceridemic carriers had LDL cholesterol concentrations exceeding 95th percentile population-based cutpoints, the prevalence of elevated values was not different between carriers and noncarrier pedigree controls exposed to similar environmental and background genetic influences (Table IV). Moreover, all carriers whose plasma triglyceride concentrations exceeded the 90th percentile had normal or decreased LDL cholesterol concen-

trations. Thus heterozygous LPL deficiency in this pedigree was expressed as familial hypertriglyceridemia.

LDL and HDL cholesterol in hypertriglyceridemia. The relationships between HDL or LDL cholesterol and plasma triglyceride or VLDL cholesterol concentrations were explored in estrogen nonusers using log-normalized age- and sex-adjusted values. HDL cholesterol decreased as VLDL cholesterol (Fig. 5) or triglyceride (analysis not shown) concentrations increased, with similar regression slopes in both carriers and noncarriers. In contrast, LDL cholesterol fell with rising plasma VLDL cholesterol (Fig. 6) or triglyceride (analysis not shown) concentrations in carriers but failed to do so in noncarriers.

An LDL/HDL ratio of 5 or greater was present in 24% of carriers and 22% of noncarriers. Although there was no statistically significant difference in the means (Table I), the LDL/HDL ratio was affected differently in carriers and noncarriers. With increasing plasma triglyceride concentration the LDL/HDL ratio rose significantly in noncarriers ($r = 0.456$; $P = 0.0001$) but failed to increase in carriers ($r = 0.126$; $P = 0.52$). This difference reflected the tendency for LDL and HDL to decrease proportionately in carriers.

Drug and gender effects. The use of drugs known to be associated with or to provoke hyperlipidemia in susceptible individuals is shown in Table V. There was modest overrepresentation of estrogen-treated women among noncarriers, whereas the prevalence of lipid-raising antihypertensive ther-

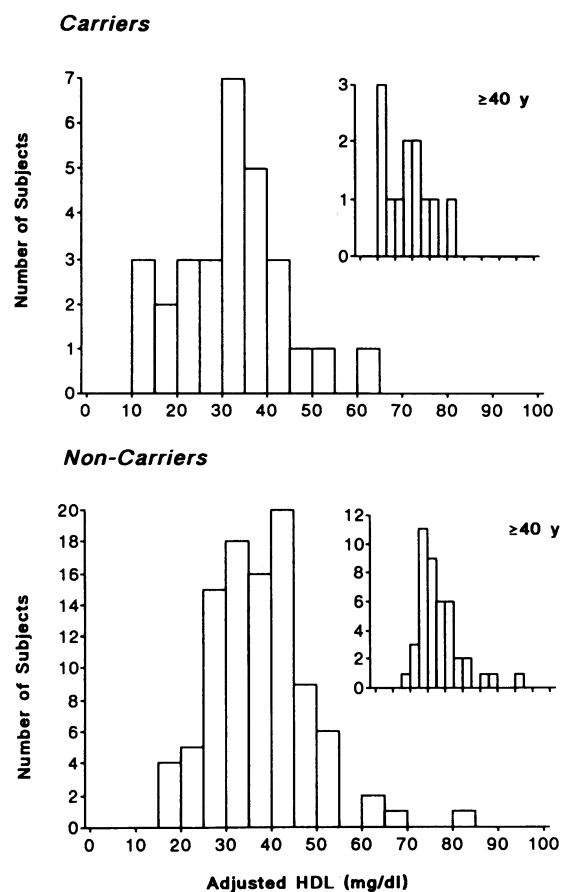

Figure 3. Histograms of age- and sex-adjusted HDL cholesterol concentration in carriers and noncarriers. (Inset) Subjects age 40 or older.

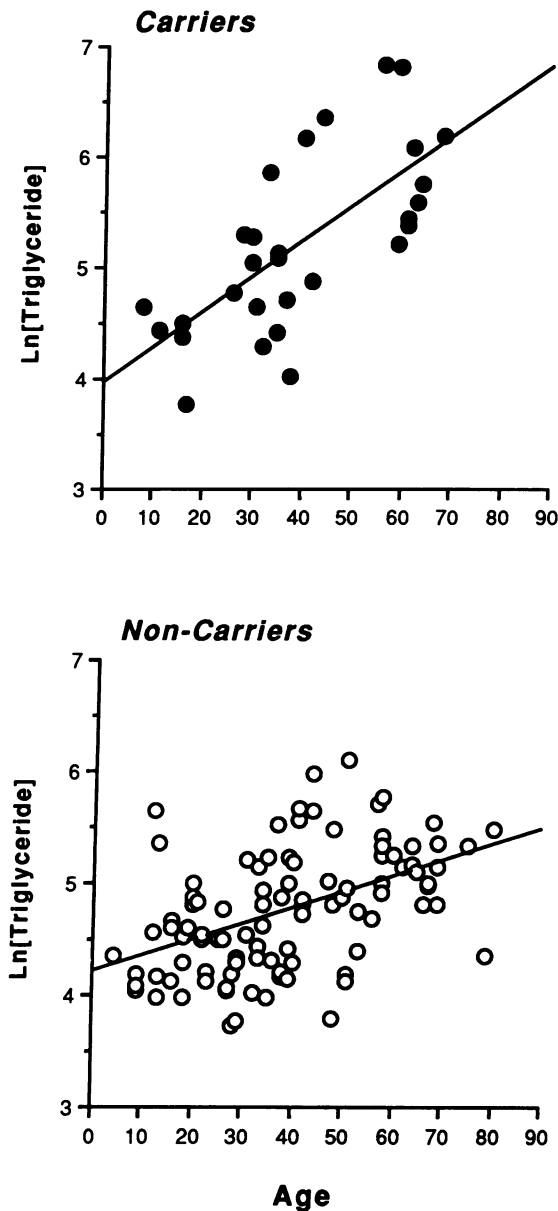

Figure 4. Linear regression of log-normalized plasma triglyceride concentration on age for carriers and noncarriers. Pearson correlation coefficients for noncarriers ($r = 0.686$; $P = 0.0001$) and carriers ($r = 0.47$; $P = 0.001$) were calculated for all subjects.

apy was greater among carriers. The overall incidence of tobacco and alcohol use was low. Although β -blocker and alcohol use (modest in all cases) were more frequent among the carriers, noncarriers and carriers were well matched in other respects.

In the multivariate analysis (Table III), there were positive correlations between variables reflecting HDL concentration (\ln [HDL cholesterol] and \ln [apolipoprotein A-I]) and female gender or estrogen use. Although thiazides and β -blockers appeared to have modest effects on lipid variables (Table II) most of these associations disappeared in the multivariate analysis (Table III). Thus, neither alcohol nor antihypertensive use could account for the observed differences between carriers and noncarriers.

Obesity and related conditions. Familial hypertriglyceridemia with or without fasting chylomicronemia is often associated with obesity, hypertension, hyperglycemia, hyperinsulinemia, and hyperuricemia (25, 27, 28). It is not known whether these associations are genetically determined, or due to lifestyle and environmental factors. Of the eight instances of non-insulin-dependent diabetes, six occurred in noncarriers and 2 (003 and 384) among carriers (Appendix and Table V). Thus, the prevalence of hyperglycemia and overt diabetes was no different between carriers and noncarriers, nor increased from the known prevalence of diabetes in the general population.

No statistically significant differences were found by univariate analysis between noncarriers and carriers in mean age, blood glucose, serum insulin, or body mass index (Table VI). However, serum uric acid was increased ($P = 0.018$) and blood pressure tended to be higher in older carriers. Hypertriglyceridemic carriers and noncarriers were older, more obese, more hyperglycemic, hyperinsulinemic, hyperuricemic, and hypertensive than normotriglyceridemic subjects of the same genotype (Table VII). As expected, these variables proved highly interdependent. Plasma insulin concentration rose with increasing body mass index both in normals and carriers ($P = 0.0001$ and $P = 0.0005$, respectively; Kendall's τ corrected for ties). Similarly plasma triglyceride concentration correlated with body mass index ($P = 0.0001$ and $P = 0.001$; analyses not shown) and with plasma insulin ($P = 0.0001$ and 0.003) in noncarriers and carriers, respectively (Fig. 7). Weaker negative correlations were also found between HDL cholesterol and plasma insulin or body mass index ($P = 0.02$ – 0.05 ; analyses not shown). Thus, conditions previously shown to be associated with familial hypertriglyceridemia were also associated

Table II. Correlation Matrix for Lipids and Lipoproteins and Potential Predictor Variables

	Age	Sex*	Carrier status*	Age · Carrier status [†]	Body mass index	Estrogen use*	Thiazide use*	β -Blocker use*
Ln (Triglyceride)	0.50 [§]	-0.17	0.29 [§]	0.45 [§]	0.42 [§]	0.09	0.22	0.26 [†]
Ln (VLDL cholesterol)	0.51 [§]	-0.12	0.30 [§]	0.45 [§]	0.34 [§]	0.09	0.17	0.24 [†]
Ln (LDL cholesterol)	0.38 [§]	0.11	-0.07	-0.06	0.17	-0.10	-0.05	-0.02
Ln (HDL cholesterol)	-0.02	0.38 [§]	-0.26 [†]	-0.28 [§]	-0.09	0.29 [§]	-0.07	-0.13
Ln (Apolipoprotein B)	0.59 [§]	-0.05	0.17	0.33 [§]	0.41 [§]	0.03	0.21	0.24 [†]
Ln (Apolipoprotein A-I)	-0.03	0.46 [§]	-0.09	-0.06	-0.10	0.41 [§]	0.05	-0.05

Log-transformed unadjusted raw data for all subjects were used. Pearson correlation coefficients were calculated after pairwise exclusion of missing values. * Numerical coding: sex (male = 0; female = 1); Carrier status (noncarrier = 0; carrier = 1); estrogen, thiazide, and β -blocker use (nonuser = 0; user = 1). [†] The variable age · carrier status was computed as the product of age and carrier status. Alcohol use was not significantly associated with any of the lipid or lipoprotein variables. [§] $P \leq 0.001$; ^{||} $P \leq 0.05$; [†] $P \leq 0.01$ (two-tailed significance).

Table III. Multiple Linear Regression Analysis of Predictor Variables for Lipid and Lipoprotein Parameters

Dependent variable	Retained predictor variables*	<i>p</i>	<i>r</i>	<i>F</i>	<i>P</i> value
Ln (Triglyceride)	Age	0.32			0.0002
	Age · Carrier status	0.35			0.0001
	Body mass index	0.21			0.01
	All variables		0.64	27.6	<0.0001
Ln (VLDL cholesterol)	Age	0.43			<0.0001
	Age · Carrier status	0.36			<0.0001
	All variables		0.62	37.2	<0.0001
Ln (LDL cholesterol)	Age	0.45			<0.0001
	Thiazide use	-0.19			0.03
	All variables		0.43	13.4	<0.0001
Ln (HDL cholesterol)	Sex	0.31			0.0003
	Age · Carrier status	-0.28			0.0006
	Estrogen use	0.18			0.04
	All variables		0.50	13.2	<0.0001
Ln (Apolipoprotein B)	Age	0.54			<0.0001
	Age · Carrier status	0.21			0.004
	All variables		0.63	38.8	<0.0001
Ln (Apolipoprotein A-I)	Sex	0.36			<0.0001
	Estrogen use	0.28			0.0008
	All variables		0.53	23.9	<0.0001

* Numerical coding is as indicated in Table II. *p*, partial correlation coefficient; *r*, multiple correlation coefficient; *F*, *F*-statistic; *P* value, probability for *t* statistic (partial correlations) or *F*-statistic. The predictor variables listed in Table II were tested by the stepwise procedure using default selection and exclusion criteria. A positive correlation with sex indicates higher HDL levels in females since the numerical code used for females was higher than that for males. Missing values were excluded pairwise.

with the expression of heterozygous LPL deficiency in this pedigree.

Separate multivariate analyses with the candidate variables showed systolic and diastolic blood pressure and uric acid to be associated with age and body mass index (Table VIII). Serum insulin concentration was associated with body mass index alone. A marginally significant independent contribution of age · carrier status to systolic blood pressure was observed even though subjects were receiving concurrent antihypertensive treatment. Although the latter observation might suggest that the mutant allele predisposes to hypertension, this conclusion is highly tentative since the number of affected carriers was small.

To further illustrate phenotypic differences between non-carriers and carriers, discriminant analysis was performed using carrier status as the grouping variable (Table IX). The discriminating variables chosen for testing were the plasma lipid and lipoprotein variables as well as other variables that might vary with carrier status. In the analysis, the strongest predictor of carrier status was plasma triglyceride concentration, followed by LDL cholesterol, and apoB. These three variables, which ostensibly reflect unique features of lipoprotein metabolism in the heterozygous state, correctly predicted carrier status in 83% of all analyzed cases.

Adipose tissue LPL activity. Knowledge of the LPL genotype in 14 (7 carriers and 7 noncarriers) of the 19 subjects previously studied in 1981 (7) permitted retrospective analysis of the ability of adipose tissue LPL activity to discriminate between carriers and noncarriers (Fig. 8). Mean activity was reduced 50% in carriers (0.60 ± 0.12 vs. 1.21 ± 0.18 nmol of free fatty acid released/mg tissue per h; means \pm SEM; $P = 0.02$ by

either Mann-Whitney U or two-tailed *t* test). However, overlap in values confirmed that measurement of adipose tissue LPL activity alone did not reliably distinguish heterozygous from normal individuals.

Discussion

We have studied the extended pedigree of a proband with type I hyperlipoproteinemia shown to be homozygous for a missense mutation in the lipoprotein lipase gene. This pedigree, notable for its size and lack of consanguinity as well as a low incidence of premature coronary artery disease and confounding variables such as alcohol abuse or tobacco use in living members (Table V), provided a unique opportunity to clarify the phenotype associated with heterozygous LPL deficiency. Carriers and noncarriers were identified by hybridization of enzymatically amplified DNA with allele-specific oligonucleotide probes. Genotyping proved essential since adipose tissue LPL activities, determined in a previous study (7) and examined retrospectively, did not detect proven carriers reliably.

The phenotype associated with heterozygous LPL deficiency in this pedigree was characterized by hypertriglyceridemia, elevated VLDL cholesterol, and low LDL and HDL cholesterol concentrations (type IV hyperlipoproteinemia), occurred together with well-recognized predisposing factors, and was transmitted in an autosomal codominant pattern. Hypertriglyceridemia in carriers proved to be strongly age dependent. Variable expression associated with age or age-related factors resulted in incomplete penetrance. Only 40% of proven carriers exhibited the abnormal phenotype. Thus, 94% of young carriers had normal triglyceride concentrations,

Table IV. Prevalence of Abnormal Lipid and Lipoprotein Concentrations among Carriers and Noncarriers

Group	Carrier status	≥ 90th percentile*		P value [‡]	≥ 95th percentile		P value
		%	n		%	n	
Total cholesterol							
All subjects (126)	Noncarriers (97)	13.4	(13)		8.2	(8)	
	Carriers (29)	17.2	(5)	—	10.3	(3)	—
Age < 40 yr (71)	Noncarriers (54)	7.4	(4)		3.7	(2)	
	Carriers (17)	11.8	(2)	—	0.0	(0)	—
Age ≥ 40 yr (55)	Noncarriers (43)	20.9	(9)		14.0	(6)	
	Carriers (12)	25.0	(3)	—	25.0	(3)	—
LDL cholesterol							
All subjects (126)	Noncarriers (97)	10.3	(10)		7.2	(7)	
	Carriers (29)	10.3	(3)	—	6.9	(2)	—
Age < 40 yr (71)	Noncarriers (54)	11.1	(6)		7.4	(4)	
	Carriers (17)	11.8	(2)	—	5.9	(1)	—
Age ≥ 40 yr (55)	Noncarriers (43)	9.3	(4)		7.0	(3)	
	Carriers (12)	8.3	(1)	—	8.3	(1)	—
Triglycerides							
All subjects (126)	Noncarriers (97)	12.4	(12)		6.2	(6)	
	Carriers (29)	31.0	(9)	0.04	27.6	(8)	0.008
Age < 40 yr (71)	Noncarriers (54)	5.6	(3)		1.9	(1)	
	Carriers (17)	5.9	(1)	—	5.9	(1)	—
Age ≥ 40 yr (55)	Noncarriers (43)	20.9	(9)		11.6	(5)	
	Carriers (12)	66.7	(8)	0.03	58.3	(7)	0.01
VLDL cholesterol							
All subjects (126)	Noncarriers (97)	20.6	(20)		8.2	(8)	
	Carriers (29)	44.8	(13)	0.03	34.5	(10)	0.005
Age < 40 yr (71)	Noncarriers (54)	7.4	(4)		3.7	(2)	
	Carriers (17)	17.6	(3)	—	0.0	(0)	—
Age ≥ 40 yr (55)	Noncarriers (43)	37.2	(16)		14.0	(6)	
	Carriers (12)	83.3	(10)	—	83.3	(10)	0.004
Group	Carrier status	≤ 10th percentile*		P value [‡]	≤ 5th percentile		P value
		%	n		%	n	
HDL cholesterol							
All subjects (126)	Noncarriers (97)	30.9	(30)		16.5	(16)	
	Carriers (29)	44.8	(13)	—	37.9	(11)	0.03
Age < 40 yr (71)	Noncarriers (54)	20.4	(11)		14.8	(8)	
	Carriers (17)	35.3	(6)	—	23.5	(4)	—
Age ≥ 40 yr (55)	Noncarriers (43)	44.2	(19)		18.6	(8)	
	Carriers (12)	58.3	(7)	—	58.3	(7)	0.04

Prevalence of abnormal values for age- and sex-corrected lipid and lipoprotein variables shown as percent of total number of individuals in each group with number of individuals in parentheses. * Cutpoints (≥ 90th and 95th percentiles for total, LDL, and VLDL cholesterol and triglyceride concentrations, and ≤ 10th and 5th percentile cutpoints for HDL cholesterol) were taken from the Lipid Research Clinics Database (24). † Levels of significance were estimated by Fisher's Exact Test.

whereas two-thirds of older carriers were hypertriglyceridemic, with plasma triglyceride concentrations in the upper decile (24). Although the statistically significant associations between selected variables and age in our cross-sectional sample point to an effect of aging itself (26), secular differences between older and younger subjects cannot be entirely ruled out.

In our previous study of this kindred three subjects had elevated LDL cholesterol values. Lacking specific markers to identify carriers, we concluded that the phenotype in the pedigree resembled familial combined hyperlipidemia. In the present study, the prevalence of increased LDL cholesterol in

proven carriers and noncarriers could be compared rigorously. Elevated LDL cholesterol concentrations were no more common among carriers than pedigree controls, nor more frequent than predicted from the distribution of LDL cholesterol concentrations extant in the general population (24). Thus in this pedigree heterozygous LPL deficiency predisposes to familial hypertriglyceridemia rather than familial combined hyperlipidemia.

Although hypertriglyceridemia, low HDL, and low LDL segregated with the mutant allele, a number of noncarriers exhibited similar abnormalities. Phenotypic differences be-

Carriers

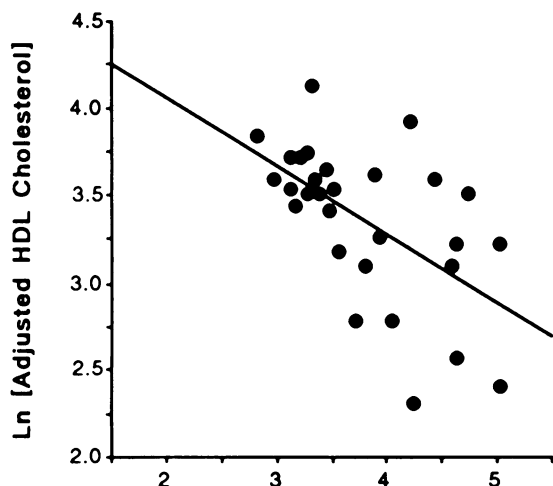

Non-Carriers

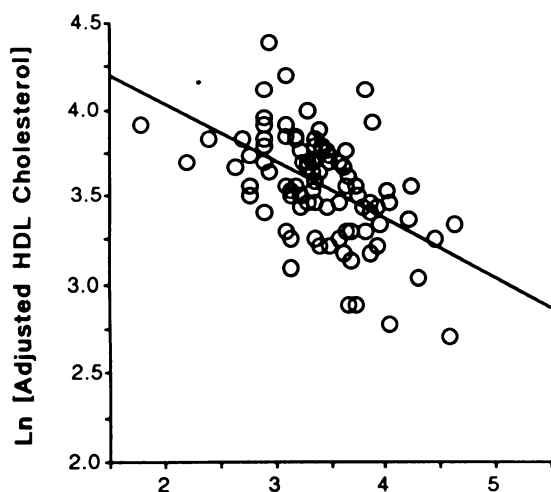

Ln [Adjusted VLDL Cholesterol]

Figure 5. Linear regression of HDL cholesterol concentration on VLDL cholesterol concentration using log-normalized age- and sex-adjusted values. Pearson correlation coefficients for carriers ($r = -0.57$; $P = 0.003$; $n = 24$) and noncarriers ($r = -0.60$; $P = 0.0001$; $n = 79$) were calculated after excluding estrogen users.

tween carriers and noncarriers were subtle. Decreased HDL cholesterol, a regular finding in hypertriglyceridemia of any cause (29), was present in both hypertriglyceridemic carriers and noncarriers in this study but was more pronounced in the former (Table I). These observations are consistent with a defect in LPL function in vivo since the plasma concentration of HDL cholesterol correlates directly with LPL activity and with fractional catabolic rate (FCR) of triglyceride or VLDL (30). Although apo A-I and A-II turnovers are increased in hypertriglyceridemia (31), plasma apo A-I concentrations, quantitatively similar to reported values (32), did not differ between groups. Thus the HDL cholesterol/apo A-I ratio was significantly reduced in carriers suggesting that the composition, but

not the number, of HDL particles is altered in heterozygous LPL deficiency.

In contrast to HDL cholesterol, which decreased with hypertriglyceridemia in both carriers and noncarriers, LDL cholesterol fell significantly in carriers only. Several mechanisms might be involved including reduced lipolytic conversion of VLDL to LDL, exchange of triglyceride for free cholesterol between VLDL and LDL, or a shift in the density distribution of triglyceride-enriched LDL particles (33). Whichever mechanism is responsible, the LDL/HDL ratio, used widely to predict atherogenic risk, was significantly correlated with plasma triglyceride concentration only in noncarriers.

Carriers

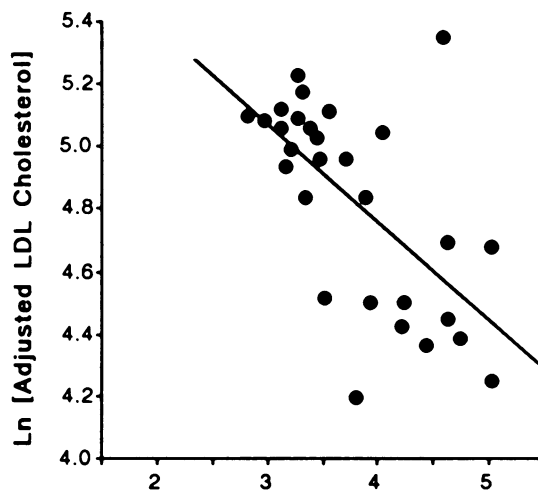

Non-Carriers

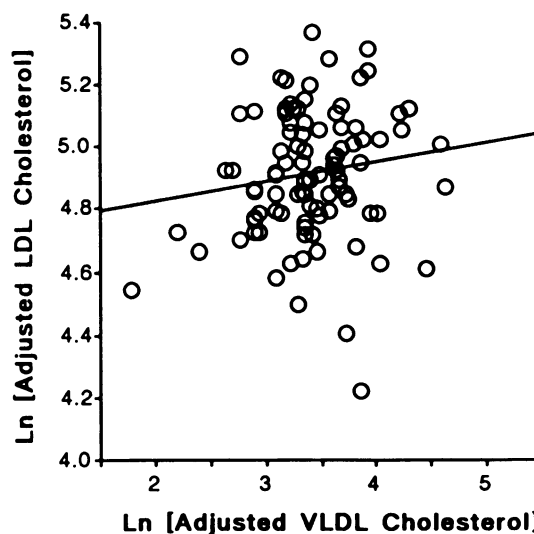

Ln [Adjusted VLDL Cholesterol]

Figure 6. Linear regression of LDL cholesterol concentration on VLDL cholesterol concentration in individuals using log-normalized age- and sex-adjusted values. Pearson correlation coefficients for carriers ($r = -0.55$; $P = 0.0005$; $n = 24$) and noncarriers ($r = 0.13$; $P = 0.2$; $n = 79$) were calculated after excluding estrogen users.

Table V. Prevalence of Medical Disorders, Drug Therapy, and Alcohol-Tobacco Use

	All subjects		Noncarriers		Carriers		P value*
	n	%	n	%	n	%	
Hypertension	27	21.4	19	19.6	8	27.6	—
Heart disease	8	6.3	7	7.2	2	6.9	—
Gout	2	1.6	1	1.0	1	3.4	—
Carbohydrate intolerance							
Known diabetes	8	6.3	6	6.2	2	6.9	—
Fasting glucose 115–139	3	2.4	2	2.1	1	3.4	—
Estrogen therapy [‡]	21/76	27.6	17/58	29.3	4/18	22.2	—
Age < 45 yr	11/53	20.8	9/41	22.0	2/12	16.7	—
Age ≥ 45 yr	10/23	43.5	8/17	47.1	2/6	33.3	—
Antihypertensive therapy	19	15.1	12	12.4	7	24.1	—
Thiazide or β-blocker	13	10.3	8	8.2	5	29.0	—
β-blocker	6	4.8	2	2.1	4	13.8	0.03
Thiazide	9	7.1	6	6.2	3	10.3	—
Gemfibrozil	1	.8	1	1.0	0	.0	—
Alcohol	14	11.1	7	7.2	7	24.1	0.03
Tobacco	5	4.0	3	3.1	2	6.9	—

* Significance levels for prevalence differences between noncarriers and carriers were calculated by Fisher's Exact Test. ‡ Percentages are based on women only. Numerators indicate numbers of women receiving estrogens, and denominators, the total number of women in each group.

Table VI. Obesity and Related Factors in Carriers and Noncarriers Stratified by Age

	Noncarriers*		Carriers		P value [‡]
	Mean	SD	Mean	SD	
All subjects (n = 126)	n = 96		n = 29		
Age (yr)	39.5	17.8	38.8	18.3	—
Systolic blood pressure (mmHg)	133	28	124	18	—
Diastolic blood pressure (mmHg)	80	16	77	11	—
Glucose (mg/dl)	94	16	93	42	—
Insulin (μU/ml)	14.2	9.9	13.8	11.7	—
Body mass index (kg/m ²)	26.2	6.8	26.7	7.2	—
Uric acid (mg/dl)	5.9	1.8	5.5	1.7	—
Age < 40 yr (n = 71)	n = 54		n = 17		
Age (yr)	25.3	9.6	26.9	9.6	—
Systolic blood pressure (mmHg)	115	12	118	11	—
Diastolic blood pressure (mmHg)	72	9	71	10	—
Glucose (mg/dl)	86	28	86	10	—
Insulin (μU/ml)	11.4	10.6	10.9	7.2	—
Body mass index (kg/m ²)	24.0	6.4	22.2	4.3	—
Uric acid (mg/dl)	5.1	1.4	4.8	1.1	—
Age ≥ 40 yr (n = 55)	n = 42		n = 12		
Age (yr)	55.8	10.9	56.6	9.3	—
Systolic blood pressure (mmHg)	136	18	151	31	—
Diastolic blood pressure (mmHg)	83	9	89	15	—
Glucose (mg/dl)	102	53	104	17	—
Insulin (μU/ml)	16.8	12.5	18.3	11.5	—
Body mass index (kg/m ²)	30.4	6.5	31.5	5.6	—
Uric acid (mg/dl)	6.1	1.8	7.4	1.3	0.02

* One insulin-treated diabetic subject (415) was excluded. ‡ Significance level determined by Mann-Whitney U corrected for ties.

Table VII. Associated Factors in Hypertriglyceridemic and Normotriglyceridemic Subjects

	Triglycerides < 90th percentile		Triglycerides ≥ 90th percentile		P value*
	Mean	SD	Mean	SD	
Carriers (29)	n = 20		n = 20		
Age (yr)	32.4	15.2	54.3	12.3	0.002
Systolic blood pressure (mmHg)	121	16	155	32	0.003
Diastolic blood pressure (mmHg)	72	11	94	13	0.001
Glucose (mg/dl)	91.1	17.6	99.3	9.7	0.03
Insulin (μU/ml)	11.1	6.4	20.7	12.8	0.03
Body mass index (kg/m ²)	24.3	6.3	30.2	6.0	0.02
Uric acid (mg/dl)	5.2	1.6	7.3	1.3	0.002
Noncarriers (96)	n = 84		n = 12		
Age (yr)	38.2	18.6	42.8	16.6	—
Systolic blood pressure (mmHg)	123	18	134	15	0.05
Diastolic blood pressure (mmHg)	76	11	83	10	0.03
Glucose (mg/dl)	93.2	43.8	95.8	26.3	—
Insulin (μU/ml)	11.8	9.0	27.8	18.3	<0.001
Body mass index (kg/m ²)	26.1	6.9	31.1	8.1	0.03
Uric acid (mg/dl)	5.3	1.5	7.3	1.9	<0.001

* Levels of significance were determined by Mann-Whitney U test corrected for ties after exclusion of data from subject 415.

Obesity, hypertension, hyperuricemia, hyperinsulinemia, mild hyperglycemia, and low HDL were all observed in hypertriglyceridemic members of kindred 2003 who were thus representative of subjects with primary hypertriglyceridemia (27, 34–37). LPL activity (38–40) has correlated directly with plasma triglyceride concentration, inversely with in vivo measures of triglyceride disposal (39), and is affected by insulin (41–44), aging, and obesity (38, 39). In addition, a significant number of hyperlipidemic subjects were receiving estrogens, thiazides, and beta-adrenergic blocking drugs despite the well-known propensity of these agents to perturb plasma lipid and lipoprotein metabolism.

Although techniques to study triglyceride kinetics have evolved significantly (45, 46), older studies clearly indicate that VLDL-TG production is highly correlated with body weight and fasting serum insulin concentration (47). Despite this prominent effect of obesity on VLDL production, maximum heparin-releasable plasma LPL activity fails to increase in obese normotriglyceridemic subjects (48). The complex interrelationships between hypertriglyceridemia and aging, obesity, insulin resistance, hyperinsulinemia, and carbohydrate intolerance have been studied intensively, yet a primary metabolic abnormality has not been accepted universally. There is experimental evidence that hyperfattyacidemia interferes with glucose disposal, increases plasma glucose concentrations, and thereby leads to hyperinsulinemia (49–52). Thus hyperinsulinemia in obesity (53) could be an epiphenomenon, rather than an independent determinant of VLDL-TG production

rate (54, 55). Regardless of the underlying mechanism, heterozygous LPL deficiency and obesity would be expected to be cooperative in the pathogenesis of hypertriglyceridemia.

This study provides independent support for the proposal (45, 56, 57) that a subset of patients with primary hypertriglyceridemia has an underlying inherited defect in triglyceride-rich lipoprotein removal consequent to impaired LPL function. Decreased LPL activity has been found in many (38, 39, 58, 59) but not all (34, 60) studies of patients with primary hypertriglyceridemia. Genetic defects in LPL, unrecognizable without specific probes for mutant alleles, might account for kinetic heterogeneity as well (57, 61). Decreased removal along with overproduction of VLDL has been observed in most

Carriers

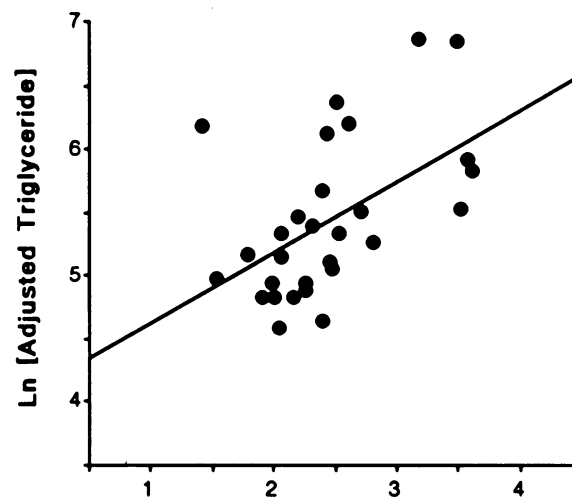

Non-Carriers

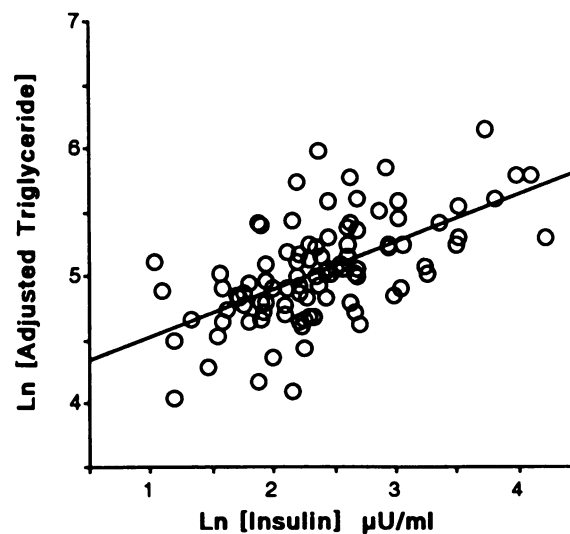

Figure 7. Linear regression of log-normalized plasma triglyceride concentration on log-normalized serum insulin in carriers and noncarriers. Pearson correlation coefficients for carriers ($r = 0.51$; $P = 0.005$; $n = 29$) and noncarriers ($r = 0.61$; $P = 0.001$; $n = 96$) were calculated after exclusion of data from subject 415. Other significant correlations existed between insulin- and log-triglyceride concentration and body mass index (see text).

Table VIII. Multiple Linear Regression Analysis of Associated Conditions

Dependent variable	Retained predictor variables*	p	r	F	P value
Ln (Systolic BP)	Age	0.45			<0.0001
	Body mass index	0.28			0.0003
	Age · Carrier status	0.16			0.02
	Sex	-0.14			0.03
	All variables		0.72	30.8	<0.0001
Ln (Diastolic BP)	Age	0.39			<0.0001
	Body mass index	0.30			0.0006
	All variables		0.61	34.4	<0.0001
Ln (Glucose)	Thiazide use	0.31			0.0003
	Sex	-0.19			0.02
	β-Blockers	0.17			0.04
	All variables		0.44	9.7	<0.0001
Ln (Insulin)	Body mass index		0.52	45.3	<0.0001
Ln (Uric acid)	Body mass index	0.36			<0.0001
	Sex	-0.34			<0.0001
	Age	0.20			0.02
	All variables		0.61	24.1	<0.0001

* Numerical coding is defined in Table II, and other symbols in Table III. The predictor variables tested were age, sex, carrier status, age · carrier status, body mass index, and thiazide, estrogen, β-blocker, or alcohol use. When blood pressure was the dependent variable, thiazide and β-blocker use were omitted from analysis. Multivariate analysis was performed as described in the legend to Table III.

(61–68) but not all (69, 70) studies. Although obesity regularly leads to VLDL-TG overproduction, overweight subjects do not necessarily become hypertriglyceridemic if their TG clearance rates increase (62); other obese subjects without an increase in clearance become hypertriglyceridemic, consistent with heterogeneity in the efficiency of triglyceride catabolism.

Defective VLDL catabolism can be familial in subjects selected for primary hypertriglyceridemia. Thus, defective removal along with reduced postheparin LPL activity was found in older subjects with “poorly classified” familial hypertriglyceridemia (65). Sane and Nikkilä (68) found decreased FCR along with increased production in index subjects in whom coexisting defects in removal and production would be expected if overt hypertriglyceridemia requires increased lipoprotein synthesis. However, decreased FCR was the only ki-

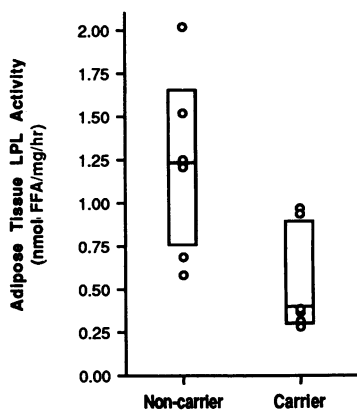

Figure 8. Adipose tissue LPL activities in seven carriers and seven noncarriers assayed previously in 1981. The median and 95% confidence intervals are indicated.

Table IX. Prediction of Carrier Status in Subjects Aged ≥ 40 yr by Discriminant Analysis

Group	Predicted				Actual	
	Noncarriers		Carriers			
	n	%	n	%	n	%
Carriers	3	25.0	9	75.0	12	100
Noncarriers	36	85.7	6	14.3	42	100

Discriminant analysis was performed using carrier status as the grouping variable. The log-transformed discriminating variables, systolic blood pressure, diastolic blood pressure, uric acid, insulin, apo A-I, apo B, and age-sex adjusted triglyceride, VLDL cholesterol, LDL cholesterol, and HDL cholesterol, were included by a stepwise selection procedure with the smallest Wilks' lambda as the selection criterion. *F*-to-enter and *F*-to-remove were set at 3.5 and 2.5, respectively. Default values were used for all other settings. The resulting discriminant function, which retained the predictor variables triglyceride, LDL cholesterol and apo B in the order mentioned, classified 83.3% of all analyzed cases correctly, assuming equal prior probability of belonging to either group.

netic abnormality segregating among the first-degree relatives of probands with a low VLDL-TG FCR (68).

Thus, our findings are consistent with the hypothesis that carriers become hypertriglyceridemic when VLDL production saturates (71, 72) the capacity of LPL to hydrolyze VLDL triglyceride; theoretically this can result from an increase in VLDL production, from LPL downregulation, or both. Such a mechanism might also explain why young homozygotes, with presumably normal or low rates of VLDL synthesis, have hyperchylomicronemia in the absence of elevated plasma VLDL (73), whereas older heterozygous carriers exhibit increased plasma VLDL concentrations.

Subjects with rare inherited metabolic disorders are often found to be compound heterozygotes at a molecular level (74). One must therefore anticipate pedigrees of LPL-deficient probands manifesting distinct allelic mutations, and others with clinically important interactions between mutant LPL genes and common non-allelic hyperlipidemia genes. Thus, if heterozygous LPL deficiency were to segregate independently along with a gene directing increased VLDL apo B synthesis, the phenotype observed in a pedigree might resemble familial combined hyperlipidemia. Whether other mutations in the LPL gene will result in clinically distinct phenotypes, or what the outcome will be of interactions of mutant LPL alleles with other more common hyperlipidemia genes remains to be investigated.

In summary, findings in this pedigree underscore the complex interactions between genetic and environmental factors that lead to hypertriglyceridemia. Heterozygosity for a mutation in the LPL gene was an important precondition for familial hypertriglyceridemia. Nevertheless, a number of noncarriers exhibited a nearly identical phenotype as they became older and heavier, and were exposed to lipid-raising drugs. Conversely, carriers of the mutant LPL allele remained normotriglyceridemic in the absence of these predisposing conditions. Since obesity, hyperinsulinemia, and the use of lipid-raising antihypertensive drugs and sex hormones are all reversible, the phenotype associated with heterozygous LPL-deficiency should be amenable to treatment. The present

results do not exclude the possibility that interacting, yet-unidentified, genes affecting lipoprotein metabolism are influencing the observed phenotype. Indeed, it is expected that multiple gene-gene interactions will eventually be implicated which, together with mutant LPL alleles, will prove to be responsible for inherited, common-phenotype hypertriglyceridemias.

Heterozygous LPL deficiency usually led to a latent abnormality in lipoprotein metabolism which by itself, was neither necessary nor sufficient for the expression of familial hypertriglyceridemia. The frequency with which heterozygous LPL deficiency is a factor in the pathogenesis of familial hypertriglyceridemia is not known. These observations provide independent genetic evidence for the existence of a subset of hypertriglyceridemic subjects with combined defects in triglyceride metabolism (56, 61).

mality in lipoprotein metabolism which by itself, was neither necessary nor sufficient for the expression of familial hypertriglyceridemia. The frequency with which heterozygous LPL deficiency is a factor in the pathogenesis of familial hypertriglyceridemia is not known. These observations provide independent genetic evidence for the existence of a subset of hypertriglyceridemic subjects with combined defects in triglyceride metabolism (56, 61).

Appendix

Individual Data

Subject No.	Age	Sex	Triglycerides	VLDL cholesterol	Total cholesterol	LDL cholesterol	apoB	HDL cholesterol	apoAI	Glucose	Insulin	Uric acid	Systolic BP	Diastolic BP	Body mass index	Illnesses, drugs, and habits
	yr					mg/dl					$\mu\text{U/ml}$	mg/dl	mmHg		kg/m^2	
Noncarriers (97)																
439	28	F	42	6	191	139	60	47	116	74	3.3	4.7	94	70	19.68	
413	29	M	43	8	160	119	61	40	135	89	7.3	6.2	138	69	27.50	
522	48	F	44	5	161	98	44	61	130	80	4.3	3.0	114	64	22.36	
409	35	F	53	8	145	91	49	43	127	84	4.7	3.7	122	73	19.96	
285	18	M	53	9	126	76	34	43	123	76	10.0	6.7	114	68	18.55	
292	13	M	54	10	138	80	34	47	143	88	5.8	6.9	108	58	18.48	
437	32	F	56	12	180	110	54	59	149	83	6.7	4.0	105	73	22.47	
344	9	M	57	9	195	141	70	44	134	81	9.2	4.1	91	56	17.87	
60	27	F	57	8	155	90	53	58	123	78	6.1	5.7	120	80	28.20	
481	27	F	58	13	145	93	53	38	109	80	4.9	3.3	100	78	19.87	
421	9	F	59	12	185	131	67	44	117	82	9.8	5.1	101	75	14.75	
478	51	M	62	11	180	121	77	41	132	65	3.3	6.9	108	76	34.30	HTN
109	16	F	62	8	147	88	35	58	140	82	13.8	3.6	112	74	27.04	
114	23	M	62	9	146	79	59	46	109	92	3.8	7.5	129	82	22.87	Alc, Tob
280	39	F	63	14	188	118	52	60	152	96	15.0	3.2	117	71	21.81	Alc
287	13	M	65	12	171	100	44	58	151	84	5.8	6.0	103	49	28.41	
107	38	F	65	10	215	148	57	62	151	86	9.1	2.7	116	92	17.79	
116	51	M	66	8	161	102	70	51	89	91	8.7	4.9	137	96	14.84	
113	28	F	66	8	182	102	61	73	136	91	6.8	7.2	125	88	46.99	
288	9	M	66	13	160	104	49	43	128	90	6.1	3.8	99	55	14.84	
322	38	F	67	8	232	180	72	52	168	87	9.6	4.3	125	88	23.90	Alc
118	23	M	67	6	158	104	59	48	109	86	14.4	4.7	124	65	30.04	
119	18	M	73	10	128	78	55	41	96	89	5.5	9.0	122	76	23.31	
430	29	F	73	13	167	120	73	34	94	88	8.1	5.7	111	64	23.79	
417	40	F	73	17	204	147	71	46	133	89	10.3	4.2	139	79	23.75	
290	36	F	74	17	218	152	61	53	206	79	5.1	5.8	102	66	26.17	E
445	29	M	76	21	210	149	73	40	102	73	8.1	5.6	97	62	24.19	Tob
479	33	F	76	15	188	130	74	43	138	76	5.6	5.1	108	78	21.66	Alc
301	79	M	77	13	170	120	56	86	101	102	9.6	9.1	162	80	33.87	HD
345	4	M	78	16	130	78	52	36	127	77	4.8	4.1	—	—	15.14	
303	53	F	81	12	191	129	64	49	135	90	9.3	6.3	120	74	39.66	HTN, E
380	39	F	82	16	240	165	84	57	143	65	6.7	5.8	121	87	29.19	DM
297	33	F	85	21	165	86	52	55	156	78	7.3	4.5	95	62	18.66	
441	22	F	90	21	194	127	71	44	107	75	3.0	5.6	110	64	20.24	E
523	26	F	90	15	145	75	46	55	124	77	8.3	2.1	112	63	22.78	E
117	25	F	90	12	153	101	71	39	99	88	4.9	4.0	109	65	20.85	E
108	18	F	92	18	160	87	52	46	137	78	26.0	3.6	110	70	25.07	
429	31	F	94	17	172	102	52	52	124	76	7.0	4.2	109	72	20.20	
341	22	M	94	20	199	139	71	43	122	74	9.2	5.2	112	79	22.57	HD
324	12	F	95	20	242	173	77	53	170	88	10.5	3.9	—	—	13.75	
286	16	F	99	20	158	92	44	46	129	84	14.8	4.1	95	62	18.85	
343	19	F	100	14	191	124	63	55	162	74	13.1	3.6	117	72	23.38	

Appendix (Continued)

Subject No.	Age	Sex	Triglycerides	VLDL cholesterol	Total cholesterol	LDL cholesterol	apoB	HDL cholesterol	apoAI	Glucose	Insulin	Uric acid	Systolic BP	Diastolic BP	Body mass index	Illnesses, drugs, and habits
	yr					mg/dl					μU/ml	mg/dl	mmHg		kg/m ²	
Noncarriers (97)																
446	34	F	101	19	173	102	60	48	140	87	11.8	5.4	126	76	27.31	DM, E
419	16	M	106	20	151	91	62	35	106	286	25.4	4.0	129	68	22.52	DM
501	56	F	109	25	187	114	79	51	146	88	7.0	6.8	101	69	22.17	E
283	42	F	114	21	176	99	49	57	166	89	8.9	3.9	122	72	26.19	
30	53	F	116	16	204	97	68	86	196	99	21.1	4.5	120	103	38.39	HTN, BpD, Tz, E
431	26	F	118	26	179	101	62	52	140	78	6.6	4.2	108	74	18.88	
174	66	M	123	23	236	166	95	47	126	117	10.8	6.3	139	83	26.25	
135	34	F	123	30	186	122	96	35	114	92	13.5	4.5	137	71	27.55	
130	42	F	123	31	198	118	80	50	129	88	11.6	4.6	134	80	26.27	
299	20	F	123	24	145	73	53	51	178	83	9.0	4.6	111	72	19.22	E
31	48	F	124	17	179	112	71	49	133	104	14.5	4.7	126	81	36.33	HTN, BpD, Tz
415	69	M	124	33	228	155	100	41	131	194	253	7.0	126	74	21.13	HD, DM (insulin), β-B
284	21	F	125	25	161	86	50	50	174	78	2.8	3.9	104	62	18.36	E
340	42	M	129	26	234	168	93	40	126	80	19.9	4.9	132	78	32.00	HD
168	50	M	130	32	274	190	109	50	123	83	11.4	6.2	139	80	29.88	Alc
418	38	F	132	21	176	115	69	36	112	84	11.0	4.6	127	78	33.94	
138	20	M	132	19	172	107	64	42	116	97	9.1	6.2	128	78	19.82	
393	58	F	138	30	241	167	74	42	118	106	14.8	6.7	146	79	31.82	
333	34	F	140	29	168	108	78	30	98	80	13.6	5.9	132	58	32.05	
477	51	F	143	31	227	142	83	43	142	96	12.8	6.9	138	86	22.12	E
143	67	M	144	24	195	127	81	42	150	87	12.4	5.4	158	91	24.03	HTN, Tz
407	58	M	148	38	250	180	93	30	101	100	11.3	6.2	122	105	26.58	HTN, BpD
386	39	F	148	41	234	133	63	61	153	75	10.6	5.4	111	73	24.28	
379	67	M	148	42	263	197	113	30	94	73	6.9	7.0	108	67	25.65	HTN, BpD
342	20	F	148	28	225	164	120	40	158	80	10.0	4.6	132	81	21.66	HTN, E
305	47	F	151	34	225	150	70	42	138	91	8.3	4.9	140	80	38.53	
414	65	F	164	35	234	142	85	52	155	93	9.9	8.1	152	84	30.15	HTN
387	33	M	170	26	210	136	67	48	136	79	18.9	9.0	116	76	27.18	
171	62	F	171	30	246	179	101	45	117	105	21.3	6.0	128	75	33.04	HD
121	69	M	173	24	206	126	75	50	121	103	18.8	4.6	185	82	22.72	HTN, BpD, Tz Alc
124	64	M	177	28	208	144	85	46	126	103	33.2	6.6	124	88	30.87	
64	40	F	178	36	221	137	101	44	127	88	14.7	4.6	110	78	33.68	
115	31	F	184	28	200	112	73	55	152	85	20.7	6.4	135	78	37.29	HTN, BpD, E Alc, Tob
436	35	F	186	49	221	133	109	42	137	83	6.5	4.8	118	82	24.06	HTN, BpD
63	39	M	188	30	170	118	58	31	100	84	68.6	6.2	139	86	38.99	
173	60	M	189	31	200	129	82	32	101	421	33.6	3.6	147	88	32.43	HTN, DM, BpD, Tz
165	58	F	191	24	195	100	55	71	168	93	11.5	5.0	144	73	35.30	E
172	58	F	205	45	232	151	90	49	132	98	13.6	3.5	143	73	30.23	E
378	64	F	207	37	235	122	66	79	203	94	13.9	7.0	140	87	27.28	HTN, BpD, E
302	75	F	208	43	296	202	104	48	157	83	6.7	6.4	128	76	27.61	
175	69	M	210	32	236	151	99	45	128	128	28.8	5.5	168	88	42.90	
110	13	M	210	30	152	87	51	30	127	85	45.3	5.9	128	80	30.42	
425	58	M	224	40	176	92	71	38	115	100	8.6	9.4	152	94	32.40	Gout
176	80	M	238	46	215	127	70	33	83	101	17.6	5.9	159	85	25.52	HD, β-B
304	48	F	239	45	287	196	105	40	129	101	20.6	6.7	152	104	44.39	
435	37	M	251	53	204	116	79	34	109	87	11.5	7.3	116	75	30.57	HTN
166	68	M	257	80	227	112	78	32	107	32	14.6	6.9	134	80	28.20	
416	41	M	258	47	150	68	71	30	115	112	33.4	8.7	159	84	35.69	HTN, BpD
420	12	M	282	44	133	61	61	28	112	83	18.7	6.0	114	67	25.69	
389	44	F	286	66	253	155	93	34	128	98	13.8	4.7	128	96	23.89	
131	41	F	291	59	246	153	95	42	147	99	53.9	6.7	132	87	33.26	HTN
385	57	F	301	66	284	167	110	52	169	86	8.9	8.0	140	83	21.33	HTN, HD, BpD, E

Appendix (Continued)

Subject No.	Age	Sex	Triglycerides	VLDL cholesterol	Total cholesterol	LDL cholesterol	apoB	HDL cholesterol	apoAI	Glucose	Insulin	Uric acid	Systolic BP	Diastolic BP	Body mass index	Illnesses, drugs, and habits
	yr					mg/dl					$\mu\text{U/ml}$	mg/dl	mmHg		kg/m ²	
Noncarriers (97)																
136	58	M	320	43	251	168	122	30	94	144	60.4	6.7	143	77	27.53	DM
123	44	M	398	102	267	131	92	28	119	82	10.7	7.4	118	82	24.77	
13	51	F	452	92	281	149	145	34	131	114	41.8	12.2	—	—	47.62	HTN, BpD, Tz
Carriers (29)																
281	17	F	43	10	165	119	53	44	125	73	11.1	4.0	—	—	—	
145	38	F	56	9	211	144	80	56	146	77	7.8	4.1	102	67	21.08	
332	32	F	73	15	183	120	53	53	123	74	8.8	4.3	112	54	23.96	
291	16	F	79	14	149	97	45	39	150	79	9.7	5.0	104	56	17.99	Alc, Tob
127	35	F	83	22	191	138	75	43	115	91	6.8	5.8	132	88	25.55	
282	11	F	84	12	179	126	43	134	92	7.4	3.4	—	—	14.46		
F 55																
323	16	M	90	18	205	144	67	45	145	92	4.7	5.5	117	75	19.30	
300	8	F	104	15	183	125	63	42	129	94	8.0	3.1	—	—	15.70	
146	31	F	104	19	167	100	69	48	127	92	12.1	3.5	127	68	20.91	
125	37	M	110	26	247	172	75	61	115	85	7.5	4.8	116	75	23.51	Alc
331	26	F	118	32	180	115	63	28	87	80	11.9	5.7	128	69	31.91	
126	42	M	131	23	221	157	79	41	139	93	9.7	5.6	116	72	28.00	Alc
128	30	F	156	26	198	139	85	36	112	94	7.9	5.2	120	75	26.25	Alc
134	35	M	161	30	216	148	75	38	124	99	6.0	5.5	132	68	22.71	
62	35	F	167	25	193	123	93	40	116	89	12.9	3.2	115	87	19.96	E
3	59	M	184	32	167	101	91	37	119	149	16.9	9.2	168	99	36.61	HTN, DM, BpD, β -B, Tz
298	30	M	195	42	128	55	57	24	92	88	10.3	7.2	118	65	24.95	
388	28	F	197	40	192	99	58	49	140	66	15.4	5.6	99	63	23.41	E
384	61	F	215	50	251	168	96	34	120	115	9.1	7.9	112	71	28.04	HTN, DM, BpD
167	61	F	229	91	359	224	117	40	152	100	34.4	6.1	139	69	38.17	
142	63	F	268	61	233	97	87	68	189	89	11.1	6.0	210	90	28.76	HTN, BpD, β-B, E
																Alc
11	64	F	317	62	186	104	84	28	111	113	38.1	8.7	144	92	40.75	HTN, HtD, gout, BpD, β-B, Tz
61	33	M	348	49	161	79	71	28	101	103	36.7	5.8	128	80	24.09	
12	62	M	442	111	249	88	113	39	105	101	11.5	6.8	172	111	32.59	HTN
122	40	M	478	86	211	78	75	36	121	107	4.2	7.8	114	72	22.50	Alc, Tob
10	68	F	483	146	263	86	125	30	151	98	13.9	6.6	197	112	25.16	HTN, BpD, Tz, E
390	44	M	575	105	215	85	89	25	113	80	12.5	9.8	142	99	28.08	HTN, BpD
2	59	F	916	102	354	119	191	30	127	100	33.8	7.7	140	99	36.21	HTN, BpD, β-B
169	56	M	936	154	338	117	94	28	123	103	24.7	6.8	152	87	33.46	Alc

Clinical variables in the 126 study subjects classified by genotype and sorted in order of ascending plasma triglyceride concentration. Subject number, age, sex, triglyceride, VLDL cholesterol, total plasma cholesterol, LDL cholesterol, apoB, HDL cholesterol, apoA-I, glucose, insulin, and uric acid concentrations, systolic and diastolic blood pressures (BP), body mass index and missing data (—) are shown. HTN, hypertension; HtD, heart disease; DM, diabetes mellitus; BpD, antihypertensive drugs of any kind; β -B, beta-adrenergic blockers; Tz, benzothiadiazides; E, estrogens; Alc, alcohol; and Tob, tobacco use. Subjects whose age- and sex-adjusted triglyceride concentrations exceed the 90th percentile cutpoint from the Lipid Research Clinics database are indicated by boldface type.

Acknowledgments

This work was supported in part by National Institutes of Health grants HL-39595, RR-00064 to the Clinical Research Center and HL-21088, by the Nora Eccles Treadwell Foundation and the Veterans Administration. J.-M. Lalouel is an Investigator at the Howard Hughes Medical Institute.

References

1. Brunzell, J. D. 1989. Familial lipoprotein lipase deficiency and other causes of the chylomicronemia syndrome. *In* The Metabolic Basis of Inherited Disease. C. R. Scriver, A. L. Beaudet, W. S. Sly, and D. Valle, editors. 6th ed. McGraw-Hill Book Co., New York. 1165-1180.

2. Nikkilä, E. A. 1983. Familial lipoprotein lipase deficiency and related disorders of chylomicron metabolism. *In* The Metabolic Basis of Inherited Disease. J. B. Stanbury, J. B. Wyngaarden, D. S. Fredrickson, J. L. Goldstein, and M. S. Brown, editors. 5th ed. McGraw-Hill Book Co., New York. 622–642.
3. Lees, R. S., D. E. Wilson, G. Schoenfeld, and S. Fleet. 1973. The familial dyslipoproteinemias. *Prog. Med. Genet.* 9:237–290.
4. Breckenridge, W. C., J. A. Little, G. Steiner, A. Chow, and M. Poapst. 1978. Hypertriglyceridemia associated with deficiency of apolipoprotein C-II. *N. Engl. J. Med.* 298:1265–1273.
5. Harlan, W. R., Jr., P. S. Winesett, and A. J. Wasserman. 1967. Tissue lipoprotein lipase in normal individuals and in individuals with exogenous hypertriglyceridemia and the relationship of this enzyme to assimilation of fat. *J. Clin. Invest.* 46:239–247.
6. Babirak, S. P., P-H. Iverius, W. Y. Fujimoto, and J. D. Brunzell. 1989. Detection and characterization of the heterozygote state for lipoprotein lipase deficiency. *Arteriosclerosis.* 9:326–334.
7. Wilson, D. E., C. Q. Edwards, and I-F. Chan. 1983. Phenotypic heterogeneity in the extended pedigree of a proband with lipoprotein lipase deficiency. *Metab. Clin. Exp.* 32:1107–1114.
8. Fellin, R., G. Baggio, A. Poli, J. Augustin, M. R. Baiocchi, G. Baldo, M. Sinigaglia, H. Greten, and G. Crepaldi. 1983. Familial lipoprotein lipase and apolipoprotein C-II deficiency. *Atherosclerosis.* 49:55–68.
9. Berger, G. M. B., and F. Bonnici. 1977. Familial hyperchylomicronemia in four families. *S. Afr. Med. J.* 51:623–628.
10. Gagné, C., D. Brun, S. Moorjani, and P-J. Lupien. 1977. Hyperchylomicronémie familiale: étude de l'activité lipolytique dans une famille. *Union Med. Can.* 106:333–338.
11. Goldstein, J. L., H. G. Schrott, W. R. Hazzard, E. L. Bierman, and A. G. Motulsky. 1973. Hyperlipidemia in coronary heart disease. II. Genetic analysis of lipid levels in 176 families and delineation of a new inherited disorder, combined hyperlipidemia. *J. Clin. Invest.* 52:1544–1568.
12. Brunzell, J. D., P-H. Iverius, M. S. Scheibel, W. Y. Fujimoto, M. R. Hayden, R. McLeod, and J. Frölich. 1986. Primary lipoprotein lipase deficiency. *In* Lipoprotein Deficiency Syndromes. A. Angel and J. Frölich, editors. Plenum Publishing Corp., New York. pp. 227–239.
13. Auwerx, J. H., S. P. Babirak, W. Y. Fujimoto, P-H. Iverius, and J. D. Brunzell. 1989. Defective enzyme protein in lipoprotein lipase deficiency. *Eur. J. Clin. Invest.* 19:433–437.
14. Scheibel, M. S., P-H. Iverius, J. D. Brunzell, J. H. Auwerx, and W. Y. Fujimoto. 1985. An enzyme linked immunosorbent assay for nondenatured human lipoprotein lipase. *Fed. Proc.* 43:1156a.(Abstr.)
15. Wion, L., T. G. Kirchgessner, A. J. Lusic, M. C. Schotz, and R. M. Lawn. 1987. Human lipoprotein lipase complementary DNA sequence. *Science (Wash. DC).* 235:1638–1641.
16. Deeb, S. S., and R. Peng. 1989. Structure of the human lipoprotein lipase gene. *Biochemistry.* 28:4131–4135.
17. Langlois, S., S. Deeb, J. D. Brunzell, J. J. Kastelein, and M. R. Hayden. 1989. A major insertion accounts for a significant proportion of mutations underlying human lipoprotein lipase deficiency. *Proc. Natl. Acad. Sci. USA.* 86:948–952.
18. Emi, M., D. E. Wilson, P-H. Iverius, L. Wu, A. Hata, R. Hegele, R. R. Williams, and J-M. Lalouel. 1990. Missense mutation (Gly → Glu₁₈₈) of human lipoprotein lipase imparting functional deficiency. *J. Biol. Chem.* 265:5910–5916.
19. Lipid Research Clinics Program. 1974. Manual of Laboratory Operations. Department of Health, Education, and Welfare (National Institutes of Health) Publ. No. 75–628.
20. Wu, L. L., G. R. Warnick, J. T. Wu, R. R. Williams, and J-M. Lalouel. 1989. A rapid micro-scale procedure for determination of the total lipid profile. *Clin. Chem.* 35:1486–1491.
21. Warnick, G. R., J. Benderson, and J. J. Albers. 1982. Dextran sulfate-Mg²⁺ precipitation procedure for quantitation of high-density-lipoprotein cholesterol. *Clin. Chem.* 28:1379–1388.
22. Siegel, S. 1956. Nonparametric Statistics for the Behavioral Sciences. McGraw-Hill Book Co., New York. 312 pp.
23. Dixon, W. J., and F. J. Massey, Jr. 1969. Introduction to Statistical Analysis. 3rd ed. McGraw-Hill Book Co., New York. 638 pp.
24. Lipid Research Clinics Population Studies Data Book. 1980. Volume I. The Prevalence Study. United States Department of Health and Human Services (Public Health Service). National Institutes of Health Publ. No. 80–1527.
25. Fredrickson, D. S., and R. I. Levy. 1972. Familial hyperlipoproteinemia. *In* The Metabolic Basis of Inherited Disease. J. B. Stanbury, J. B. Wyngaarden, and D. S. Fredrickson, editors. 3rd ed. McGraw-Hill Book Co., New York. 592–604.
26. Greenfield, M. S., F. Kraemer, and G. Reaven. 1980. Effect of age on plasma triglyceride concentrations in man. *Metab. Clin. Exp.* 29:1095–1099.
27. Fredrickson, D. S., R. I. Levy, and R. S. Lees. 1967. Fat transport in lipoproteins: an integrated approach to mechanisms and disorders. *N. Engl. J. Med.* 276:34–44, 94–103, 148–156, 215–227, 273–281.
28. Modan, M., H. Halkin, A. Lusky, P. Segal, F. Fuchs, and A. Chetrit. 1988. Hyperinsulinemia is characterized by jointly disturbed plasma VLDL, LDL, and HDL levels. *Arteriosclerosis.* 8:227–236.
29. Nikkilä, E. A., M-R. Taskinen, and T. Sane. 1987. Plasma high-density lipoprotein concentration and subfraction distribution in relation to triglyceride metabolism. *Am. Heart J.* 113:543–548.
30. Kekki, M. 1980. Lipoprotein-lipase action determining plasma high density lipoprotein cholesterol level in adult normolipemic. *Atherosclerosis.* 37:143–150.
31. Saku, K., P. S. Gartside, B. A. Hynd, S. G. Mendoza, and M. L. Kashyap. 1985. Apolipoprotein AI and AII metabolism in patients with primary high-density lipoprotein deficiency associated with familial hypertriglyceridemia. *Metab. Clin. Exp.* 34:754–764.
32. Kuusi, T., C. Ehnholm, J. Viikari, R. Härkönen, E. Vartiainen, P. Puska, and M-R. Taskinen. 1989. Postheparin plasma lipoprotein and hepatic lipase are determinants of hypo- and hyperalphalipoproteinemia. *J. Lipid Res.* 30:1117–1126.
33. Minnich, A., B. G. Nordestgaard, and D. B. Zilversmit. 1989. A novel explanation for the reduced LDL cholesterol in severe hypertriglyceridemia. *J. Lipid Res.* 30:347–355.
34. Krauss, R. M., R. I. Levy, and D. S. Fredrickson. 1974. Selective measurement of two lipase activities in postheparin plasma from normal subjects and patients with hyperlipoproteinemia. *J. Clin. Invest.* 54:1107–1124.
35. Goldstein, J. L., W. R. Hazzard, H. G. Schrott, E. L. Bierman, and A. G. Motulsky. 1973. Hyperlipidemia in coronary heart disease. I. Lipid levels in 500 survivors of myocardial infarction. *J. Clin. Invest.* 52:1533–1543.
36. Glueck, C. J., R. I. Levy, and D. S. Fredrickson. 1969. Immuno-reactive insulin, glucose tolerance, and carbohydrate inducibility in Types II, II, IV, and V hyperlipoproteinemia. *Diabetes.* 18:739–747.
37. Greenberg, B. H., W. C. Blackwelder, and R. I. Levy. 1977. Primary type V hyperlipoproteinemia. A descriptive study in 32 families. *Ann. Int. Med.* 87:526–534.
38. Persson, B. 1973. Lipoprotein lipase activity of human adipose tissue in different types of hyperlipidemia. *Acta Med. Scand.* 193:447–456.
39. Huttunen, J. K., C. Ehnholm, M. Kekki, and E. A. Nikkilä. 1976. Post-heparin plasma lipoprotein lipase and hepatic lipase in normal subjects and patients with hypertriglyceridaemia: correlations to sex, age and various parameters of triglyceride metabolism. *Clin. Sci. Mol. Med.* 50:249–260.
40. Huttunen, J. K., C. Ehnholm, E. A. Nikkilä, and M. Ohta. 1975. Effect of fasting on two postheparin plasma triglyceride lipases and triglyceride removal in obese subjects. *Eur. J. Clin. Invest.* 5:435–445.
41. Nikkilä, E. A., J. K. Huttunen, and C. Ehnholm. 1977. Post-heparin plasma lipoprotein lipase and hepatic lipase in diabetes mellitus. *Diabetes.* 26:11–21.
42. Kessler, J. I. 1963. Effect of diabetes and insulin on the activity

- of myocardial and adipose tissue lipoprotein lipase. *J. Clin. Invest.* 42:362-367.
43. Wilson, D. E., R. Zeikus, and I-F. Chan. 1987. Relationship of organ lipoprotein lipase activity and ketonuria to hypertriglyceridemia in starved and streptozocin-induced diabetic rats. *Diabetes.* 36:485-490.
44. Ong, J. M., T. G. Kirchgessner, M. C. Schotz, and P. A. Kern. 1988. Insulin increases the synthetic rate and messenger RNA level of lipoprotein lipase in isolated rat adipocytes. *J. Biol. Chem.* 263:12933-12938.
45. Nikkilä, E. A., and M. Kekki. 1973. Plasma triglyceride transport kinetics in diabetes mellitus. *Metab. Clin. Exp.* 22:1-22.
46. Zech, L. A., S. M. Grundy, D. Steinberg, and M. Berman. 1979. Kinetic model for production and metabolism of very low density lipoprotein triglycerides. *J. Clin. Invest.* 63:1262-1273.
47. Eaton, R. P., and W. H. R. Nye. 1973. The relationship between insulin secretion and triglyceride concentration in endogenous lipemia. *J. Lab. Clin. Med.* 81:682-695.
48. Wilson, D. E., B. W. Glad, P. K. Working, and M. E. Adler. 1978. Postheparin plasma lipase activities in obesity: failure to increase with adipose organ enlargement. *Metab. Clin. Exp.* 27:1084-1094.
49. Thiébaud, D., R. A. DeFronzo, E. Jacot, A. Golay, K. Acheson, E. Maeder, E. Jéquier, and J-P Felber. 1982. Effect of long chain triglyceride infusion on glucose metabolism in man. *Metab. Clin. Exp.* 31:1128-1136.
50. Ferrannini, E., E. J. Barrett, S. Bevilacqua, and R. A. DeFronzo. 1983. Effect of fatty acids on glucose production and utilization in man. *J. Clin. Invest.* 72:1737-1747.
51. Meylan, M., C. Henny, E. Temier, E. Jéquier, and J. P. Felber. 1987. Metabolic factors in the insulin resistance in human obesity. *Metab. Clin. Exp.* 36:256-261.
52. Bevilacqua, S., R. Bonnadonna, G. Buzzigoli, C. Boni, D. Cio-ciario, F. Maccari, M. A. Giorco, and E. Ferrannini. 1987. Acute elevation of free fatty acid levels leads to hepatic insulin resistance in obese subjects. *Metab. Clin. Exp.* 36:502-506.
53. Berson, S. A., and R. S. Yalow. 1965. Some current controversies in diabetes research. *Diabetes.* 14:549-572.
54. Olefsky, J. M., J. W. Farquhar, and G. M. Reaven. 1974. Reappraisal of the role of insulin in hypertriglyceridemia. *Am. J. Med.* 57:551-560.
55. Reaven, G. M., R. L. Lerner, M. P. Stern, and J. W. Farquhar. 1967. Role of insulin in endogenous hypertriglyceridemia. *J. Clin. Invest.* 46:1756-1767.
56. Grundy, S. M. 1984. Pathogenesis of hyperlipoproteinemia. *J. Lipid Res.* 25:1611-1618.
57. Grundy, S. M., and G. L. Vega. 1988. Hypertriglyceridemia: causes and relation to coronary heart disease. *Sem. Thromb. Hemostasis.* 14:149-164.
58. Taylor, K. G., G. Holdsworth, D. J. Galton. 1980. Lipoprotein lipase in adipose tissue and plasma triglyceride clearance in patients with primary hypertriglyceridaemia. *Eur. J. Clin. Invest.* 10:133-138.
59. Taskinen, R-R., E. A. Nikkilä, and T. Kuusi. 1982. Lipoprotein lipase activity of adipose tissue, skeletal muscle and post-heparin plasma in primary endogenous hypertriglyceridaemia: relationship to lipoprotein pattern and to obesity. *Eur. J. Clin. Invest.* 12:433-438.
60. Goldberg, A. P., A. Chait, and J. D. Brunzell. 1980. Postprandial adipose tissue lipoprotein lipase activity in primary hypertriglyceridemia. *Metab. Clin. Exp.* 29:223-229.
61. Kesaniemi, A., and S. M. Grundy. 1984. Dual defect in metabolism of very-low-density lipoprotein triglycerides. Patients with Type 5 hyperlipoproteinemia. *JAMA (J. Am. Med. Assoc.).* 251:2542-2547.
62. Grundy, S. M., H. Y. I. Mok, L. Zech, D. Steinberg, and M. Berman. 1979. Transport of very low density lipoprotein triglycerides in varying degrees of obesity. *J. Clin. Invest.* 63:1274-1283.
63. Packard, C. J., J. Shepherd, S. Joerns, A. M. Gotto Jr., and O. D. Taunton. 1980. Apolipoprotein B metabolism in normal, Type IV, and Type V hyperlipoproteinemic subjects. *Metab. Clin. Exp.* 29:213-222.
64. Janus, E. D., A. M. Nicoll, P. R. Turner, P. Magill, and B. Lewis. 1980. Kinetic bases of the primary hyperlipidaemias: studies of apolipoprotein B turnover in genetically defined subjects. *Eur. J. Clin. Invest.* 10:161-172.
65. Beil, U., S. M. Grundy, J. R. Crouse, and L. Zech. 1982. Triglyceride and cholesterol metabolism in primary hypertriglyceridemia. *Arteriosclerosis.* 2:44-57.
66. Stalenhoef, A. F. H., P. N. M. Demacker, J. A. Lutterman, and A. van't Laar. 1986. Plasma lipoproteins, apolipoproteins, and triglyceride metabolism in familial hypertriglyceridemia. *Arteriosclerosis.* 6:387-394.
67. Dunn, F. L., S. M. Grundy, D. W. Bilheimer, R. J. Havel, and P. Raskin. 1985. Impaired catabolism of very low-density lipoprotein-triglyceride in a family with primary hypertriglyceridemia. *Metab. Clin. Exp.* 34:316-324.
68. Sane, T., and E. A. Nikkilä. 1988. Very low density lipoprotein triglyceride metabolism in relatives of hypertriglyceridemic probands. Evidence for genetic control of triglyceride removal. *Arteriosclerosis.* 8:217-226.
69. Chait, A., J. J. Albers, and J. D. Brunzell. 1980. Very low density lipoprotein overproduction in genetic forms of hypertriglyceridaemia. *Eur. J. Clin. Invest.* 10:17-22.
70. Kissebah, A. H., S. Alfarsi, and P. W. Adams. 1981. Integrated regulation of very low density lipoprotein triglyceride and apolipoprotein-B kinetics in man: normolipemic subjects, familial hypertriglyceridemia and familial combined hyperlipidemia. *Metab. Clin. Exp.* 30:856-868.
71. Reaven, G. M., D. B. Hill, R. C. Gross, and J. W. Farquhar. 1965. Kinetics of triglyceride turnover of very low density lipoproteins of human plasma. *J. Clin. Invest.* 44:1826-1833.
72. Brunzell, J. D., W. R. Hazzard, D. Porte, Jr., and E. L. Bierman. 1973. Evidence for a common, saturable, triglyceride removal mechanism for chylomicrons and very low density lipoproteins in man. *J. Clin. Invest.* 52:1578-1585.
73. Lees, R. S., and D. S. Fredrickson. 1965. The differentiation of exogenous and endogenous hyperlipemia by paper electrophoresis. *J. Clin. Invest.* 44:1968-1977.
74. Beaudet, A. L., C. R. Scriver, W. S. Sly, D. Valle, D. N. Cooper, V. A. McKusick, and J. Schmidke. 1989. Genetics and biochemistry of variant human phenotypes. In *The Metabolic Basis of Inherited Disease.* C. R. Scriver, A. L. Beaudet, W. S. Sly, and D. Valle, editors. 6th edition. McGraw-Hill Book Co., New York. 28-30.