

A Model for cAMP-mediated cGMP Response in *Dictyostelium discoideum*

Romi Valkema and Peter J.M. Van Haastert

Department of Biochemistry, University of Groningen, Nijenborgh 4,
9747 AG Groningen, The Netherlands

Submitted February 2, 1994; Accepted March 28, 1994
Monitoring editor: Roger Y. Tsien

In *Dictyostelium discoideum* extracellular cyclic AMP (cAMP), as shown by previous studies, induces a transient accumulation of intracellular cyclic guanosine-5'-monophosphate (cGMP), which peaks at 10 s and recovers basal levels at 30 s after stimulation, even with persistent cAMP stimulation. Additional investigations have shown that the cAMP-mediated cGMP response is built up from surface cAMP receptor-mediated activation of guanylyl cyclase and hydrolysis of cGMP by phosphodiesterase. The regulation of these activities was measured in detail on a seconds time-scale, demonstrating complex adaptation of the receptor, allosteric activation of cGMP-phosphodiesterase by cGMP, and potent inhibition of guanylyl cyclase by Ca^{2+} . In this paper we present a computer model that combines all experimental data on the cGMP response. The model is used to investigate the contribution of each structural and regulatory component in the final cGMP response. Four models for the activation and adaptation of the receptor are compared with experimental observations. Only one model describes the magnitude and kinetics of the response accurately. The effect of Ca^{2+} on the cGMP response is simulated by changing the Ca^{2+} concentrations outside the cell (Ca^{2+} influx) and in stores (IP_3 -mediated release) and changing phospholipase C activity. The simulations show that Ca^{2+} mainly determines the magnitude of the cGMP accumulation; simulations are in good agreement with experiments on the effect of Ca^{2+} in electroporated cells. Finally, when cGMP-phosphodiesterase activity is deleted from the model, the simulated cGMP response is elevated and prolonged, which is in close agreement with the experimental observations in mutant *stmF* that lacks this enzyme activity. We conclude that the computer model provides a good description of the observed response, suggesting that the main structural and regulatory components have been identified.

INTRODUCTION

The slime mold *Dictyostelium discoideum* lives in the soil where it feeds on bacteria. Upon food depletion, the unicellular amoebae organize in a multicellular slug, in which differentiation occurs. The cells in the anterior part develop into stalk cells, whereas the cells in the posterior part will become spores (Schaap and Wang, 1986). The development of *Dictyostelium* is triggered by cAMP, which is secreted by the amoebae upon starvation (Konijin, 1972). Neighboring cells are capable of responding to the cAMP gradient by means of cAMP receptors in the cell membrane (Malchow and Gerisch, 1974; Green and Newell, 1975; Henderson, 1975; Mato and Konijn, 1975). Stimulation of these receptors trig-

gers a cascade of reactions, which finally results in cell movement towards the increasing concentration of cAMP (Gerisch *et al.*, 1975).

Upon stimulation of the cAMP receptor the intracellular enzymes guanylyl cyclase and phospholipase C are rapidly activated (Mato and Malchow, 1978; European-Finner and Newell, 1987). Consequently the concentrations of cyclic guanosine-5'-monophosphate (cGMP), inositol 1,4,5-trisphosphate¹ (IP_3), and Ca^{2+} increase, myosin is phosphorylated, and actin polymerizes, eventually resulting in enhanced and directed cell motility (Malchow *et al.*, 1981; McRobbie and Newell, 1984;

¹ Abbreviations used: IP_3 , inositol 1,4,5-trisphosphate.

Europe-Finner and Newell, 1986a,b; Liu and Newell, 1988). *Dictyostelium* exhibits chemotaxis towards different chemoattractants like cAMP and folic acid (Konijn *et al.*, 1967; Pan *et al.*, 1972). The role of cGMP in chemotaxis has been emphasized in *stmF*, a mutant which, due to the absence of cGMP-specific phosphodiesterase, has an increased cGMP response and shows prolonged chemotactic movement towards cAMP and folic acid (Ross and Newell, 1981; Van Haastert *et al.*, 1982). The conclusion that cGMP is involved in chemotaxis was recently confirmed in experiments with mutant KI8. This mutant, with strongly reduced guanylyl cyclase activity, shows no chemotaxis to either cAMP or folic acid (Kuwayama *et al.*, 1993).

cGMP levels start to increase at ~ 1 s after stimulation of the cells with cAMP; peak levels are achieved 10 s later (Van Haastert, 1987a). Subsequently the concentration of cGMP declines to reach basal levels at ~ 30 s (Mato *et al.*, 1977). Several experiments suggest that the receptor-mediated cGMP response is regulated by complex mechanisms (Van Haastert and Van der Heyden, 1983). Although the peak values of the cGMP response depend on the stimulus concentration, the kinetics of the response is essentially independent with respect to the cAMP concentration. Extracellular cAMP is degraded by phosphodiesterase activity in the medium (Chang, 1968; Malchow *et al.*, 1972; Panbacker and Bravard, 1972). The magnitude and kinetics of the cGMP response remain the same whether the cAMP stimulus is present for only 3 s or is not degraded at all (Van Haastert and Van der Heyden, 1983). Finally, when cells are stimulated twice at 30-s interval, they respond only to the second stimulus if the concentration is higher than that of the first stimulus (Van Haastert, 1983a). These experiments indicate that the receptor-mediated cGMP response is regulated by an adaptation mechanism.

Biochemically, the cGMP response is controlled at two points: synthesis by guanylyl cyclase and degradation by phosphodiesterase. Guanylyl cyclase is stimulated by the receptor (Mato and Malchow, 1978). Previous studies have indicated that adaptation of the cGMP response occurs upstream of guanylyl cyclase (Van Haastert, 1983a), presumably at the receptor or at the $G\alpha 2$ -protein (Okaichi *et al.*, 1992). Detailed kinetic studies of cAMP binding to *D. discoideum* cells suggest that a subpopulation of surface receptors is involved in the activation of guanylyl cyclase and that adaptation is associated at the interconversions between active and inactive receptor forms (Van Haastert *et al.*, 1986). Guanylyl cyclase activity is inhibited by Ca^{2+} ions (Janssens *et al.*, 1989; Valkema and Van Haastert, 1992), suggesting that the cGMP response is regulated by receptor-stimulated Ca^{2+} uptake as well as by phospholipase C and IP_3 via the release of Ca^{2+} from internal stores (Streb *et al.*, 1983; Bumann *et al.*, 1984; Van Haastert *et al.*, 1989). Two classes of phosphodiesterases

participate in intracellular cGMP degradation. Intracellular cGMP is degraded mainly by a cGMP-specific enzyme that is stimulated by cGMP at low concentrations. About 20% of intracellular cGMP is degraded by a less specific enzyme (Van Haastert *et al.*, 1983). In summary, the cGMP response is controlled by a cGMP-stimulated phosphodiesterase and Ca^{2+} -inhibited guanylyl cyclase, which is stimulated by a surface cAMP receptor that is subjective to adaptation. The contribution of each of these regulatory components to the final cGMP response is essentially unknown and can not easily be determined in experiments.

The kinetic values of nearly all biochemical reactions described above have been determined in previous experiments on the time scale of the cGMP response (seconds). To determine the contribution of receptor adaptation, Ca^{2+} inhibition of guanylyl cyclase and cGMP-stimulated phosphodiesterase activity to the final cGMP response we translated the observed reactions and kinetic values of all enzymes into a model. This model consists of five differential equations that describe the activated cAMP receptor, the changes in the concentration of cGMP, IP_3 and Ca^{2+} , and the activity of cGMP-specific phosphodiesterase, respectively. Different adaptation mechanisms were investigated, revealing that a specific adaptation regime is essential to describe the observed transient response. The model predicts that adaptation determines the appearance of the cGMP response curve, Ca^{2+} inhibition of guanylyl cyclase determines the magnitude of the response, whereas the cGMP stimulated phosphodiesterase determines the duration of the response. Finally the cGMP response in two signal transduction mutants was simulated by deleting phosphodiesterase activity and phospholipase C activity from the model; the predictions were similar to experimental data. We conclude that the model describes experimental data, suggesting that the main structural and regulatory elements of cGMP metabolism are included into the model.

MATERIALS AND METHODS

The relations between the different components that determine intracellular cGMP levels are presented in Figure 1. cGMP is degraded mainly by a cGMP-stimulated phosphodiesterase. Guanylyl cyclase produces cGMP; the enzyme is stimulated by an activated receptor (denoted by R^*) and is inhibited by intracellular Ca^{2+} levels. The concentration of Ca^{2+} is controlled by receptor-stimulated IP_3 levels and by receptor-stimulated Ca^{2+} uptake. The change of cGMP concentration is given by Eq. 1, where f_{SYN} is the synthesis of cGMP and f_{DEG} is its degradation.

$$\frac{d[\text{cGMP}]}{dt} = f_{SYN} - f_{DEG} \quad (1)$$

cGMP Synthesis

The enzyme guanylyl cyclase hydrolyzes guanosine 5'-triphosphate to cGMP. In *Dictyostelium* this enzyme is likely a membrane-associated

protein (Mato and Malchow, 1978; Janssens *et al.*, 1989). The rate of cGMP synthesis is given by

$$f \text{ SYN} = \left[1 - \eta \frac{[\text{Ca}^{2+}]^n}{[\text{Ca}^{2+}]^n + [\text{K}_1]^n} \right] [\delta + \epsilon R^*] \quad (1a)$$

where η is the fraction of guanylyl cyclase that is sensitive to Ca^{2+} inhibition. In vitro all guanylyl cyclase activity is sensitive to Ca^{2+} inhibition ($\eta = 1$); in electroporated cells $\sim 20\%$ of guanylyl cyclase activity remains active in the presence of 1 mM Ca^{2+} ($\eta = 0.8$) (Van Haastert, unpublished results). K_1 is the concentration of Ca^{2+} that induces half-maximal inhibition ($\text{K}_1 = 200$ nM); inhibition of guanylyl cyclase by Ca^{2+} is a cooperative process with a Hill coefficient $n = 2.3$ (Janssens *et al.*, 1989; Valkema and Van Haastert, 1992). δ and ϵ represent the enzyme activity of guanylyl cyclase in basal and receptor-activated state, respectively. The values of these constants have been measured and are given in Table 1.

cGMP Degradation

The hydrolysis of cGMP to 5'-GMP is performed by two cyclic nucleotide phosphodiesterase activities: a small phosphodiesterase activity hydrolyzing cAMP and cGMP at approximately the same rate and a large activity specific for cGMP (Chang, 1968; Van Haastert *et al.*, 1983). cGMP stimulates the latter enzyme about threefold by decreasing the K_m of the enzyme at an unaltered V_{\max} (Bulgakow and Van Haastert, 1983). The activity of phosphodiesterases in the model is designated by the following equation:

$$f \text{ DEG} = (1 - \theta) V_G \frac{[\text{cGMP}]}{[\text{cGMP}] + \text{K}_M^L} + \theta V_G \frac{[\text{cGMP}]}{[\text{cGMP}] + \text{K}_M^H} + V_A \frac{[\text{cGMP}]}{[\text{cGMP}] + \text{K}_M^A} \quad (1b)$$

In this equation V_G and V_A are the V_{\max} of the cGMP-specific and the nonspecific enzyme, respectively; K_M^L and K_M^H are the Michaelis-Menten constants of the cGMP-specific enzyme in the low and high active form, respectively. K_M^A is the Michaelis-Menten constant of the nonspecific phosphodiesterase. θ is the fraction of the cGMP specific enzyme in the activated state, which is given by

$$\frac{d\theta}{dt} = k_{\theta} [\text{cGMP}] (1 - \theta) - k_{-\theta} \theta \quad (1c)$$

k_{θ} and $k_{-\theta}$ are allosteric rate constants of activation and deactivation of the cGMP-specific phosphodiesterase. Detailed studies of cGMP degradation have provided the values of all constants (Van Haastert and Van Lookeren Campagne, 1984), which are given in Table 1.

Regulation of Intracellular Ca^{2+} Levels

Calcium ions inhibit guanylyl cyclase activity. Stimulation of the cAMP receptor induces influx of extracellular Ca^{2+} (Bumann *et al.*, 1984) and activates phospholipase C whereby phosphatidylinositol-bisphosphate is hydrolyzed to IP_3 and diacylglycerol. IP_3 liberates Ca^{2+} from non-mitochondrial internal stores (Europe-Finner and Newell, 1986a). The IP_3 concentration is given by

$$\frac{d[\text{IP}_3]}{dt} = \alpha + \beta R^* - \gamma [\text{IP}_3] \quad (2a)$$

where α and β are the basal and receptor-stimulated activity of phospholipase C, respectively (Bominaar *et al.*, 1994), and γ is the first order rate constant of IP_3 degradation (Van Lookeren Campagne *et al.*, 1988).

The Ca^{2+} concentration of the cytosol is described by:

$$\begin{aligned} \frac{d[\text{Ca}^{2+}]_{\text{cytosol}}}{dt} = & \frac{V_c^L [\text{Ca}^{2+}]_{\text{out}}}{\text{K}_m^{\text{cL}} + [\text{Ca}^{2+}]_{\text{out}}} \\ & + \frac{V_c^H [\text{Ca}^{2+}]_{\text{out}}}{\text{K}_m^{\text{cH}} + [\text{Ca}^{2+}]_{\text{out}}} R^* + \left[C + D \frac{[\text{IP}_3]^M}{[\text{IP}_3]^M + q^M} \right] [\text{Ca}^{2+}]_{\text{store}} \\ & - E [\text{Ca}^{2+}]_{\text{cytosol}} - F [\text{Ca}^{2+}]_{\text{cytosol}} \quad (2b) \end{aligned}$$

The first part of the equation denotes the plasma membrane channels that transport Ca^{2+} to the cytosol, which follow Michaelis-Menten kinetics. Activation of the receptor alters both the V_{\max} and the K_m of the transport. The values of these constants have been measured (Millne and Coukell, 1991) and are presented in Table 1.

The second part of the equation represents the IP_3 -mediated release of Ca^{2+} from nonmitochondrial stores (Europe-Finner and Newell, 1986a). Details of this reaction have not been determined in *Dictyostelium*; we assume values of reaction constants, which have been measured in mammalian cells (Streb *et al.*, 1983; Champeil *et al.*, 1989). The Ca^{2+} concentration in the IP_3 -sensitive store is assumed to be 1 mM. The release of Ca^{2+} from the store by IP_3 is assumed to occur in a co-operative way, with a Hill coefficient $M = 2$ and a half-maximal activity at $q = 1.10 \mu\text{M}$.

The third part of the equation denotes the Ca^{2+} pump activity E back to the extracellular medium and F back to the intracellular store. In unstimulated cells the influx of Ca^{2+} from the extracellular medium equals the efflux:

$$\frac{V_c^L [\text{Ca}^{2+}]_{\text{out}}}{\text{K}_m^{\text{cL}} + [\text{Ca}^{2+}]_{\text{out}}} = E [\text{Ca}^{2+}]_{\text{cytosol}} \quad (2c)$$

Assuming a basal cytosolic Ca^{2+} concentration of 5×10^{-8} M (Abe *et al.*, 1988) and an extracellular Ca^{2+} concentration of $10 \mu\text{M}$ (Bumann *et al.*, 1984) implies $E = 6 \text{ s}^{-1}$. In unstimulated cells the efflux from the intracellular Ca^{2+} store equals the flux of Ca^{2+} ions pumped back in this store yielding $F = 6 \text{ s}^{-1}$.

Activation and Adaptation of the Surface cAMP Receptor

Binding of cAMP to the surface receptor induces the accumulation of cGMP levels. The response is transient with maximal cGMP levels at 10 s and a recovery of basal cGMP levels after 30 s, even during persistent stimulation with cAMP. Partial desensitization could be provided by the Ca^{2+} -mediated inhibition of guanylyl cyclase and cGMP-stimulation of cGMP-phosphodiesterase; this will be investigated in a model called simple adaptation. Several experiments suggest that desensitization is mediated by adaptation occurring at the level of the cAMP surface receptor (Van Haastert and Van der Heijden, 1983; Van Haastert, 1987b). Therefore alternative models were analyzed for different adaptation regimes.

Simple Adaptation. The binding of cAMP to the receptor is a simple bimolecular reaction, and the occupied receptor remains in the activated state (Scheme 1). Adaptation does not occur at the receptor, but intracellularly at the level of cGMP synthesis or degradation. The differential equation for the occupied activated receptor R^*L is

$$\frac{dR^*L}{dt} = k_1 [\text{cAMP}] (1 - R^*L) - k_{-1} R^*L \quad (3a)$$

Linear Adaptation. This model introduces the adapted occupied receptor state R^*L , which is formed from the activated occupied receptor R^*L (Scheme 2). The differential equation for the activated occupied receptor R^*L and for the occupied receptor R^*L are

$$\begin{aligned} \frac{dR^*L}{dt} = & k_1 [\text{cAMP}] (1 - R^*L - R^*L) - k_{-1} R^*L - k_2 R^*L + k_{-2} R^*L \\ \frac{dR^*L}{dt} = & k_2 R^*L - k_{-2} R^*L \quad (3b) \end{aligned}$$

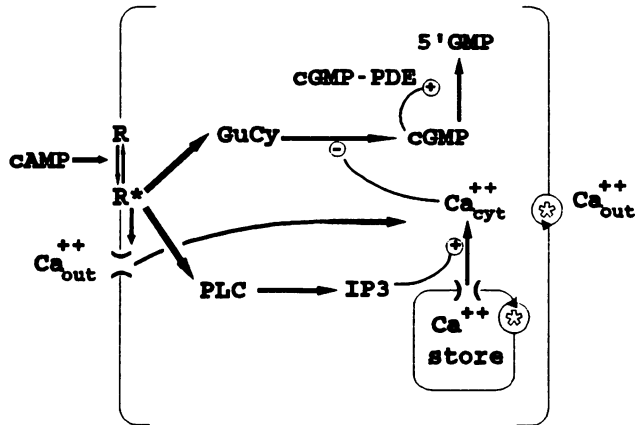

Figure 1. Schematic representation of intramolecular interactions contributing to the cGMP response in *Dictyostelium discoideum*. R, cAMP receptor; R*, stimulated cAMP receptor; GuCy, guanylyl cyclase; PLC, phospholipase C; cGMP-PDE, cGMP-stimulated cGMP-specific phosphodiesterase.

Box-model. The receptor box-model is based on a study on the activation of adenylyl cyclase in *Dictyostelium* (Goldbeter and Koshland, 1982; Knox *et al.*, 1986). The model assumes two interconvertible forms of the receptor R^S and R^D , respectively. Each form of the receptor can associate with the ligand cAMP, yielding $R^S L$ and $R^D L$, respectively (Scheme 3). All four receptor states possess a specific activity a_x . The total receptor activity R^* is denoted as follows:

$$R^* = a_1 R^S + a_2 R^S L + a_3 R^D L + a_4 R^D \quad (3c)$$

Experimental data indicate that the association of ligand to the receptor is much faster than the interconversion between the receptor forms, thus

$$\begin{aligned} \frac{dR^D}{dt} &= k_3 R^S - k_{-3} R^D \\ \frac{dR^{DL}}{dt} &= \frac{k_4 R^S [cAMP]}{K_R} - \frac{k_{-4} R^D [cAMP]}{K_D} \end{aligned} \quad (3d)$$

Cycle-model. The cycle-model describes the adaptation process as a series of sequential interconversions of receptor forms. This model was based on kinetic studies of the interaction between cAMP and a subpopulation of receptors that are supposed to be involved in the activation of guanylyl cyclase (Van Haastert *et al.*, 1986) (Scheme 4). cAMP binds reversibly to the receptor, yielding RL. This receptor form converts with the rate k_x to the activated state of the receptor $R^* L$. k_x is not a constant, but declines with time according to $k_x = 0.22e^{-0.17t} \text{ s}^{-1}$. The active receptor $R^* L$ then converts to a desensitized state $R^D L$ with a rate constant $k_y = 0.17 \text{ s}^{-1}$. $R^D L$ slowly converts back to the inactive receptor RL with $K_z = 7.3 \times 10^{-3} \text{ s}^{-1}$ (Van Haastert *et al.*, 1986; Van Haastert, 1987b). The differential equations for the different receptor forms are

$$\begin{aligned} \frac{dR^* L}{dt} &= k_x RL - k_y R^* L \\ \frac{dR^D L}{dt} &= k_y R^* L - k_z R^D L \\ \frac{dRL}{dt} &= k_1 [cAMP] (1 - RL - R^* L - R^D L) - k_{-1} RL - k_x RL \end{aligned} \quad (3e)$$

RESULTS

Adaptation of the Model

A typical cGMP response of starved *Dictyostelium* cells upon cAMP stimulation is shown in Figure 2A. After a delay of ~ 1 s the cellular cGMP concentration increases and reaches a peak level at 10 s; basal conditions are recovered at 30 s after the addition of the stimulus. In vivo measurements show that the magnitude of the response increases with increasing concentrations of the cAMP stimulus, whereas the kinetics of the cGMP response is essentially independent of the stimulus concentration. Furthermore, cGMP levels always return to prestimulus concentrations at ~ 30 s after cAMP stimulation, independent of the dynamics of the stimulus (rapid or no degradation of cAMP; Van Haastert and Van der Heyden, 1983). In this section four adaptation models are investigated on the kinetics of the cGMP response. Simulations were performed for 50 s with constant cAMP concentrations at 10^{-8} , 10^{-7} , and 10^{-6} M.

The Simple Adaptation Model. Previous experiments revealed inhibition of guanylyl cyclase by Ca^{2+} and stimulation of cGMP-phosphodiesterase by cGMP. The simple adaptation model investigates whether these negative control elements are sufficient to explain the observed desensitization of the cGMP response. This model predicts (Figure 2B) that the cGMP concentration will reach a peak at 10 s after stimulation; the cAMP dose dependency of the cGMP response also agrees with experimental observations. Furthermore, cGMP levels do decline after 10 s of stimulation. However, this decline is only $\sim 15\%$ of the cGMP peak at 10 s, which is far less than observed experimentally. Thus, although the cGMP response in this simple adaptation model already shows some adaptation characteristics, cGMP levels do not recover basal levels according to experimental observations. We conclude that the simple model shows poor desensitization, indicating that the negative regulation of guanylyl cyclase by Ca^{2+} and the positive regulation of phosphodiesterase by cGMP are insufficient to obtain complete desensitization. In the subsequent models adaptation will be included at the level of the receptor.

The Linear-adaptation Model. In this model the activated receptor $R^* L$ converts to a desensitized form $R^D L$. The Linear-adaptation model predicts a cGMP peak between 6 and 9 s after stimulation (Figure 2C). The response is cAMP-dose dependent. However, the response does not adapt completely: at 50 s after stimulation the cGMP concentration is still 15% above basal level. Furthermore, the model predicts specific kinetics of the response, which have not been observed experimentally: the response and recovery to basal levels is fast at high concentrations of cAMP and slow at low concentrations.

Table 1. Kinetic values of enzymes involved in the cAMP-induced cGMP response in *Dictyostelium discoideum*

Constant	Unit	Value	Description	Reference
η	—	0.8	Fraction of GuCy that is sensitive for Ca^{2+}	[1]
n	—	2.3	Hill-coefficient of inhibition of GuCy by Ca^{2+}	[2, 3]
K_i	M	2×10^{-7}	$[Ca^{2+}]$ giving half-maximal inhibition of GuCy	[2, 3]
δ	$M \cdot s^{-1}$	4.0×10^{-8}	Basal activity of GuCy	[4]
ϵ	$M \cdot s^{-1}$	1.7×10^{-6}	Activity of stimulated GuCy	[4]
V_G	$M \cdot s^{-1}$	2×10^{-6}	Hydrolytic activity of cGMP-specific PDE	[5]
V_A	$M \cdot s^{-1}$	2×10^{-7}	Hydrolytic activity of nonspecific PDE	[6]
K_m^H	M	5.4×10^{-6}	K_m of activated cGMP-specific PDE	[5]
K_m^L	M	2.4×10^{-5}	K_m of basal cGMP-specific PDE	[5]
K_m^A	M	2.5×10^{-6}	K_m of nonspecific PDE	[6]
k_θ	$M^{-1} \cdot s^{-1}$	1.4×10^{-5}	Rate constant of activation of cGMP-specific PDE	[5]
$k_{-\theta}$	s^{-1}	2.0×10^{-2}	Rate constant of deactivation of cGMP-specific PDE	[5]
α	$M \cdot s^{-1}$	7.5×10^{-8}	Basal activity of PLC	[7]
β	$M \cdot s^{-1}$	7.5×10^{-7}	Activity of stimulated PLC	[7]
γ	s^{-1}	7.0×10^{-1}	Rate of degradation of IP_3	[8]
V_c^L	$M \cdot s^{-1}$	4.8×10^{-6}	V_{max} of unstimulated Ca^{2+} channel	[9]
V_c^H	$M \cdot s^{-1}$	1.04×10^{-5}	V_{max} of stimulated Ca^{2+} channel	[9]
K_m^{cL}	M	1.15×10^{-4}	K_m of unstimulated Ca^{2+} channel	[9]
K_m^{cH}	M	1.85×10^{-5}	K_m of stimulated Ca^{2+} channel	[9]
C	s^{-1}	3×10^{-4}	Basal Ca^{2+} release from IP_3 -sensitive store	[10]
D	s^{-1}	3×10^{-3}	As C, activated by IP_3	[10]
E	s^{-1}	6	Rate of Ca^{2+} pump from cytosol to extracellular	[10]
F	s^{-1}	6	Rate of Ca^{2+} pump from cytosol to store	[10]
M	—	2	Hill-coefficient of Ca^{2+} channel for IP_3	[10]
q	M	7×10^{-7}	K_m of Ca^{2+} channel for IP_3	[10]
$[Ca^{2+}]_{out}$	M	10^{-5}	$[Ca^{2+}]$ outside the cell	[11]
$[Ca^{2+}]_{store}$	M	10^{-3}	$[Ca^{2+}]$ inside the store	[12]
k_1	$M^{-1} \cdot s^{-1}$	2×10^7	Rate constant of association of cAMP to receptor R	[14]
k_{-1}	s^{-1}	7×10^{-1}	Rate constant of dissociation of cAMP receptor complex	[14]
k_2	s^{-1}	1.7×10^{-1}	Converting rate constant from R^*L to R^{DL}	[12]
k_{-2}	s^{-1}	7.3×10^{-3}	Converting rate constant from R^{DL} to R^*L	[12]
k_3	s^{-1}	5.78×10^{-4}	Converting rate constant of R^S to R^D	[13]
k_{-3}	s^{-1}	5.2×10^{-3}	Converting rate constant of R^D to R^S	[13]
k_4	s^{-1}	1.6×10^{-1}	Converting rate constant of R^{PL} to R^SL	[13]
k_{-4}	s^{-1}	1.73×10^{-2}	Converting rate constant of R^SL to R^{PL}	[13]
a_1	—	1.0×10^{-1}	Specific activity of R^S	[13]
a_2	—	1	Specific activity of R^SL	[13]
a_3	—	1.9×10^{-4}	Specific activity of R^{DL}	[13]
a_4	—	7.0×10^{-2}	Specific activity of R^D	[13]
K_R	M	1.5×10^{-8}	Dissociation constant of R^SL	[13]
K_D	M	1.5×10^{-8}	Dissociation constant of R^{DL}	[13]
k_x	s^{-1}	$0.22e^{-0.17t}$	Converting rate constant from RL to R^*L	[14]
k_y	s^{-1}	1.7×10^{-1}	Converting rate constant from R^*L to R^{DL}	[14]
k_z	s^{-1}	7.3×10^{-3}	Converting rate constant from R^{DL} to RL	[14]

References: [1] Van Haastert, unpublished observations; [2] Janssens *et al.*, 1989; [3] Valkema and Van Haastert, 1992; [4] Mato and Malchow, 1978; [5] Van Haastert and Van Lookeren Campagne, 1984; [6] Malchow *et al.*, 1972; [7] Bominaar *et al.*, 1994; [8] Van Lookeren Campagne *et al.*, 1988; [9] Millne and Coukell, 1991; [10] Champeil *et al.*, 1989; Streb *et al.*, 1983; [11] Bumann *et al.*, 1984; [12] estimated; [13] based on Knox *et al.*, 1986; and [14] Van Haastert *et al.*, 1986.

The Box-adaptation Model. The model is based on experimental observations of cAMP-binding to surface receptors that are supposed to interact with adenylyl cyclase in *Dictyostelium* (Knox *et al.*, 1986). cAMP can interact with two interconvertible forms of the receptor; each of the occupied and unoccupied receptor forms

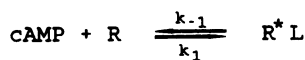

Scheme 1.

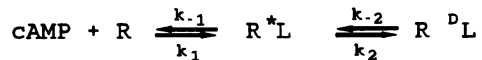

Scheme 2.

possesses different activity. Simulation of the box-adaptation model reveals complete adaptation of the cGMP response at each stimulus concentration (Figure 2D). The model predicts that the kinetics of the cGMP

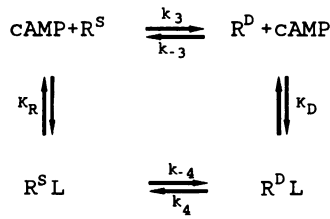

Scheme 3.

response alters at different concentrations of the cAMP stimulus: at higher stimulus concentrations the response increases and returns to basal levels faster than at lower stimulus concentrations. This has not been observed for the cAMP-stimulation of guanylyl cyclase (see Figure 2A). Furthermore, the model predicts that the rate of cGMP increase is maximal immediately after cAMP addition (Figure 2D), whereas experimental observations reveal a 1-s lag period between cAMP addition and the increase of cGMP levels (see Figure 2A, inset) (Van Haastert, 1987a). Although the box-adaptation model predicts perfect adaptation, several properties of the predicted response are not in good agreement with experimental observations for the cGMP response.

The Cycle-adaptation Model. This model is based on experimental observations on the binding of cAMP to a subpopulation of surface cAMP receptors that are supposed to be involved in the activation of guanylyl cyclase (Van Haastert, 1987b). cAMP binds reversibly to the inactive receptor R, which sequentially converts to an active form R* and to a desensitized form R^D, which slowly recovers to the inactive receptor R. The rate constants of these interconversions have been measured (Van Haastert, 1987b). The cycle-model predicts a response, which shows perfect adaptation (Figure 2E). Furthermore, the kinetics of the response is independent of the cAMP stimulus concentration. Finally, the predicted response exhibits a short delay before the cGMP concentration rises rapidly to a peak at 8–10 s; basal levels are recovered at 30 s after stimulation.

Considering these data we conclude that the cycle-adaptation model fits best with experimental observations. Therefore this cycle-model was used to perform the following experiments on the role of cGMP-phosphodiesterase and intracellular Ca²⁺.

cGMP Degradation

Intracellular cGMP is hydrolyzed by two cyclic nucleotide phosphodiesterases: a nonspecific phosphodiesterase with low activity and a cGMP-specific cGMP-phosphodiesterase with high activity (Van Haastert *et al.*, 1983). The latter enzyme is stimulated about threefold by cGMP with a half-time of ~20 s (Van Haastert and Van Lookeren Campagne, 1984). The role of the cGMP-specific phosphodiesterase for the receptor-stimulated cGMP response was studied by simulating the absence of cGMP specific enzyme activity (V_G = 0) or by simulating an enzyme that can not be activated by cGMP (k_θ = 0). The results (Figure 3A) reveal in both cases that the cGMP response is increased and prolonged. When cGMP can not activate the enzyme, cGMP peak levels are increased with a factor 1.7 relative to the response with normal phosphodiesterase; the cGMP peak is reached at 14 s and basal levels are recovered after 50 s. When the enzyme is absent, the cGMP response is enhanced with a factor of 3.5 relative to the control response; the peak is reached after 22 s, and basal levels do not recover within 100 s.

A *Dictyostelium* mutant *stmF* has been isolated that lacks the cGMP-specific phosphodiesterase (Ross and Newell, 1981; Van Haastert *et al.*, 1982). The cAMP-mediated cGMP response in this mutant (Figure 3B) closely resembles the calculated cGMP levels: a prolonged and increased response, with recovery of the basal cGMP levels at 100–120 s after stimulation.

Intracellular Ca²⁺ Levels
 Guanylyl cyclase in *Dictyostelium* is strongly inhibited by intracellular Ca²⁺ ions with half-maximal inhibition at 200 nM and a Hill coefficient of 2.3 (Valkema and Van Haastert, 1992). Cytosolic Ca²⁺ concentrations are regulated in a complex manner that are not completely understood in *Dictyostelium*. In the model we have incorporated experimental data on the cAMP surface receptor-mediated uptake of Ca²⁺ and on the release of Ca²⁺ from intracellular stores by IP₃ that is produced by receptor stimulated phospholipase C. The role of Ca²⁺ was investigated by simulating the absence of phospholipase C activity and modifying Ca²⁺ concentrations in the extracellular medium or in the intracellular stores.

Intracellular Ca²⁺ Levels

Removal of phospholipase C activity from the model predicts a cGMP response that is only 1.2-fold higher than the response of cells that do possess phospholipase C activity (Figure 4A). This calculated response can be compared with experimental observations on strain HD10, which was obtained by disruption of the *Dictyostelium* phospholipase C gene; in this mutant cAMP

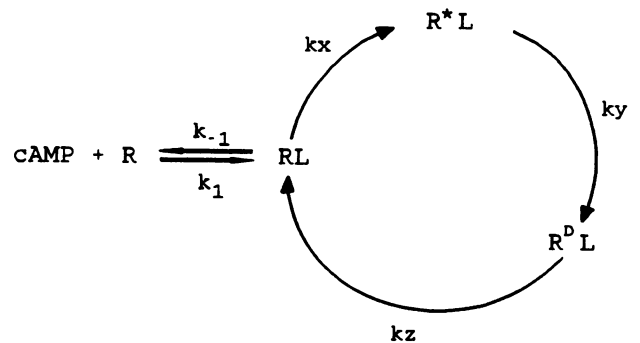

Scheme 4.

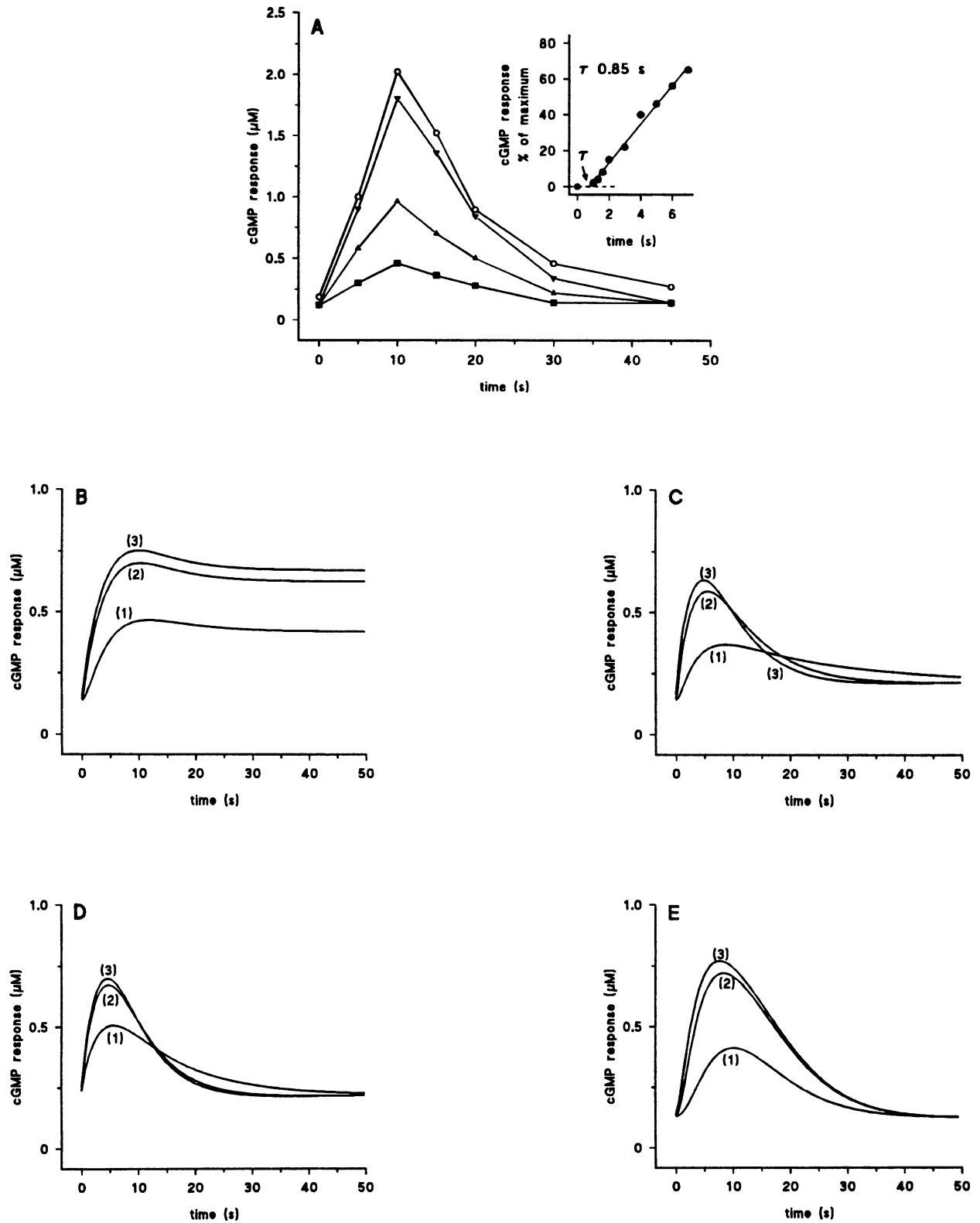

Figure 2. Time course of cGMP formation upon stimulation with different cAMP concentrations. (A) Experimental observations, cAMP = 2×10^{-9} M (■), 10^{-8} M (▲), 10^{-7} M (▼), 10^{-6} M (○). *Inset:* Kinetics of excitation of cGMP response, cAMP = 10^{-7} M (redrawn from Van Haastert, 1987a). (B-E) Time course of cGMP formation in computer simulations according to different receptor models: simple-adaptation, (B); linear-adaptation, (C); box-adaptation, (D); circle-adaptation, (E). The concentrations of cAMP are (1) 10^{-8} M, (2) 10^{-7} M, (3) 10^{-6} M.

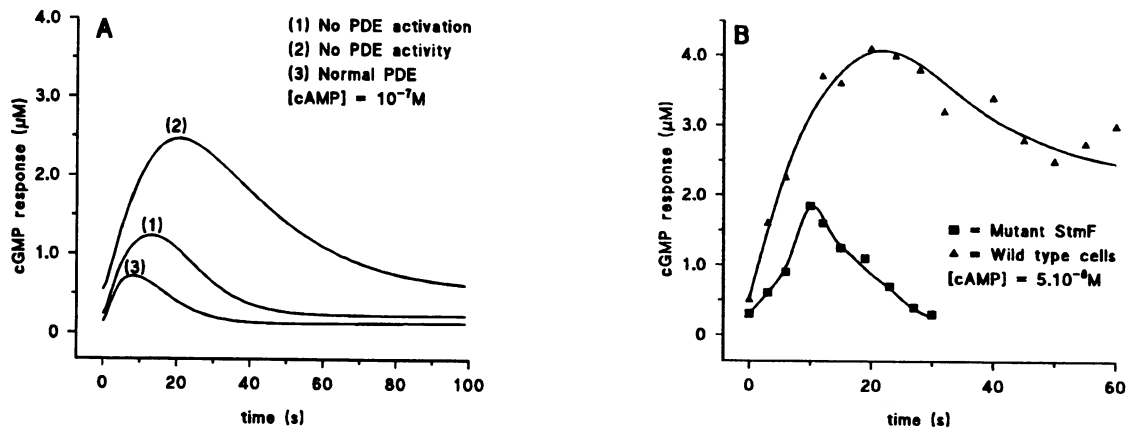

Figure 3. Effect of cGMP-specific phosphodiesterase on the cGMP response. Panel A, computer simulations performed with 10^{-7} M cAMP and different phosphodiesterase conditions. Panel B: experimentally observed cGMP response in *Dictyostelium* wild type and mutant *stmF*, which is defective in phosphodiesterase activity (redrawn from Ross and Newell, 1981).

induces the nearly normal cGMP accumulation (Drayer *et al.*, 1994). This suggests that the receptor-mediated activity of phospholipase C and subsequent expected release of Ca^{2+} does not significantly contribute to the cGMP response.

The removal of extracellular Ca^{2+} predicts a cGMP response that is 1.6-fold higher than the response of control cells (Figure 4A). Total depletion of Ca^{2+} inside and outside the cell gives a response that is 1.9-fold higher than the normal response. In both cases of changing the Ca^{2+} concentration, the kinetics of the response are unaltered; i.e., the peak is reached at the same time and cGMP levels recover with the same rate. When a constant intracellular Ca^{2+} concentration of 10^{-3} M is applied to the model, basal cGMP levels are reduced about fourfold and cAMP induces only a small cGMP response ($\sim 35\%$ of the normal response; Figure

4A). Experimental observations with electroporated cells in Ca^{2+} -free buffer (HEPES/5.9 mM EGTA) show a large cGMP increase upon stimulation with cAMP (Figure 4B). Electroporated cells in the presence of $1 \mu\text{M}$ or 1 mM Ca^{2+} have reduced basal cGMP levels and show only a slight increase in cGMP levels after cAMP stimulation (Figure 4B).

DISCUSSION

Extracellular cAMP is a chemoattractant for *Dictyostelium* cells, inducing cell aggregation and differentiation. Cells are stimulated by a wave of cAMP that is emitted from the aggregation center. As the wave approaches the cell, the cAMP gradient has two characteristics: the cAMP concentration increases with time and the gradient points towards the aggregation center, leading the

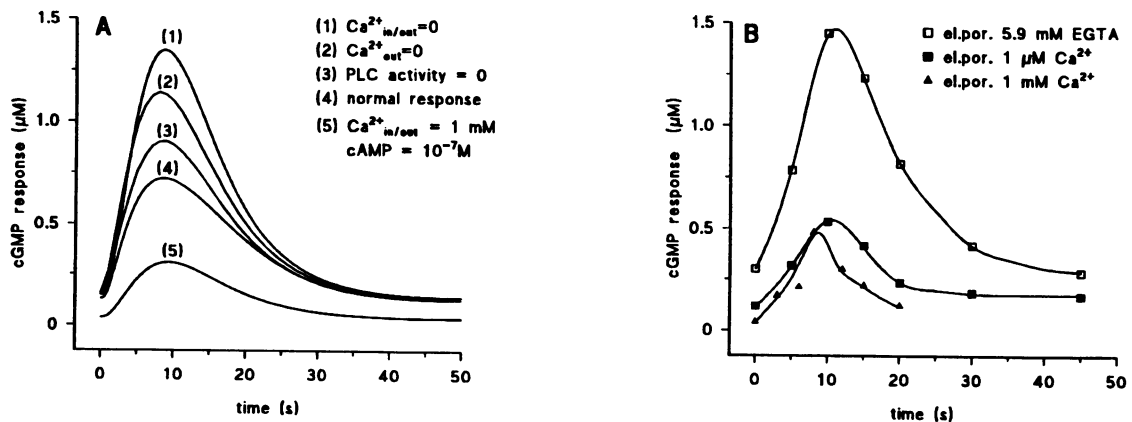

Figure 4. Effect of Ca^{2+} ions on cGMP response. (A) Computer simulation of the cGMP response under varying Ca^{2+} concentrations or without phospholipase C activity. (B) Experimentally observed cGMP response in electroporated *Dictyostelium* cells in HEPES/5.9 mM EGTA buffer (□), in HEPES/5.9 mM EGTA/5.9 mM CaCl_2 yielding $1 \mu\text{M}$ free Ca^{2+} (■), or HEPES/5.9 mM EGTA/6.9 mM CaCl_2 yielding 1 mM free Ca^{2+} (▲).

cell in this direction. When the maximal cAMP concentration of the wave passes the cell, both the spatial and temporal component of the cAMP gradient reverse: the direction of the gradient points away from the aggregation center and the cAMP concentration decreases with time. If cells would respond to this concentration gradient, they would move away from the aggregation center. Observations reveal that cells show directed movement on the rising flank of the cAMP wave and random movement after the wave has passed the cells (Alcantara and Monk, 1974). *Dictyostelium* cells extend pseudopods in the direction of the gradient within a few seconds upon stimulation with cAMP (Gerisch *et al.*, 1975). Rapid excitation in combination with perfect and rapid adaptation of the signal transduction cascade could explain the observations on directed cell movement when a cAMP wave passes the cells (Van Haastert, 1983b).

Chemotaxis is a complex reaction combining temporal and spatial information of the cAMP gradient. Several experiments suggest that the second-messenger cGMP has an important function during chemotaxis. First, the kinetics of excitation and adaptation of the cGMP response are in good agreement with the kinetics of pseudopod formation during chemotaxis. Second, *stmF* mutants lacking a cGMP phosphodiesterase, show an enhanced cGMP response and prolonged chemotactic movement (Ross and Newell, 1981; Van Haastert *et al.*, 1982). Third, nonchemotactic mutants have recently been isolated that do not respond to chemoattractants that are detected by different surface receptors; these KI mutants have a defect in the central sensory transduction cascade shared by different chemoattractants (Kuwayama *et al.*, 1993). Biochemical analysis reveal that most mutants show an altered cGMP response, varying from no guanylyl cyclase activity to an altered balance between excitation and adaptation of cGMP formation.

The cAMP-mediated cGMP response in *Dictyostelium* is composed of a network of activation and adaptation of surface cAMP receptor, activation of guanylyl cyclase, inhibition of this enzyme by Ca^{2+} ions, and cGMP stimulation of a cGMP-specific phosphodiesterase. We have studied the enzymes that are involved in the formation of the cGMP response. To understand the function of each of the components that participate in the cGMP response in relation to chemotaxis, a computer model for simulation experiments was designed, which is based almost entirely on experimental data. Detailed kinetic analysis of the components provides the framework for the model.

Four models on the adaptation of the receptor were investigated. Each model predicts different dynamics of the cGMP response, and only one model is in sufficient agreement with experimental data. This cyclic-adaptation model is based on observations on the interaction between cAMP and a subpopulation of receptors sup-

posed to be coupled to the activation of guanylyl cyclase (Van Haastert *et al.*, 1986; Van Haastert, 1987b). The less favorable box-adaptation model that was proposed for the adaptation of adenylyl cyclase predicts different kinetics of the cGMP response at different stimulus concentrations, which have not been observed experimentally. Two other more simple adaptation models, the simple-adaptation model and the linear-adaptation model, show insufficient adaptation. Although the cyclic-adaptation model predicts all aspects of the cGMP response, its biochemical background is not completely understood. The interconversions of receptor forms that are observed *in vivo* can be induced by guanine nucleotides *in vitro*, suggesting that they are related to the altered interaction of the activated receptors with G-proteins.

The role of activation of cGMP-phosphodiesterase by cGMP was investigated in the model as well as experimentally. The model predicts that cGMP-phosphodiesterase affects both the magnitude and especially the duration of the cGMP response. Previous experiments with mutant *stmF*, which lacks the cGMP-phosphodiesterase, support the conclusions of the model. This suggests that cGMP-phosphodiesterase functions by rapidly attenuating the cGMP response, even before guanylyl cyclase activity has completely recovered basal levels due to adaptation. During cell aggregation the cAMP concentration gradient directs movement to the aggregation centre for ~ 1.5 min, which is the period that the cAMP concentration increases with time. In mutant *stmF* the cAMP gradient has probably the same concentration profile, but cells respond to the gradient for nearly 3 min. This suggests that cells continue to move in the same direction as long as cGMP levels are elevated and that the function of the phosphodiesterase is to immediately erase the information contained in the cGMP response as soon as the cAMP concentration is no longer increasing with time.

Dictyostelium guanylyl cyclase is strongly regulated by nanomolar Ca^{2+} concentrations. Because the occupied surface cAMP receptor stimulates both guanylyl cyclase and an increase of cytosolic Ca^{2+} levels (Saran *et al.*, 1994) (via Ca^{2+} uptake and possibly via IP_3 -mediated release from internal stores), the exact regulation of cGMP levels upon stimulation are not easily understood. Experiments on the effect of Ca^{2+} on cGMP levels in electropermeabilized cells reveal that Ca^{2+} reduces both basal and receptor-stimulated cGMP levels, but has no strong effect on the duration of the response (Valkema and Van Haastert, 1992). The model predicts essentially this outcome, except that the effects of Ca^{2+} are stronger in the model than in the experiment. This notion is especially valid for the effect of removing extracellular Ca^{2+} and deletion of phospholipase C. In the model this will result in 1.7- and 1.3-fold increase of the response, but experiments reveal little effect of removing extracellular Ca^{2+} (Valkema and Van Haastert,

1992) or phospholipase C (Drayer *et al.*, 1994). This observation suggests that the regulation of guanylyl cyclase by Ca^{2+} may have been described appropriately, but that receptor-stimulated alterations of cytosolic Ca^{2+} concentrations are not completely understood. It should be noted that cytosolic Ca^{2+} levels have not been determined in detail upon cAMP stimulation of *Dictyostelium* cells.

In this study the dynamics of the cGMP response in time were investigated. Because chemotaxis combines temporal and spatial information of chemoattractant concentration, the next step will be to analyze the spatial distribution of cGMP during chemotactic movement. Unfortunately, cGMP levels can not be measured yet in single cells, leaving only calculations to provide some insight in this process. The present investigations suggest that the main components that affect the kinetics of cGMP response have been identified. This information is now to be combined with estimated values for the spatial distribution of receptors, guanylyl cyclase and phosphodiesterase, and with diffusion of cGMP, IP_3 , and Ca^{2+} inside the cell.

Summarizing we conclude that receptor adaptation is responsible for the kinetics of the cGMP response. The activity of cGMP-stimulated cGMP-specific phosphodiesterase controls the magnitude and especially the duration of the cGMP response. The regulation of the guanylyl cyclase activity by Ca^{2+} ions gives *Dictyostelium* the opportunity for fine tuning of the cGMP response.

ACKNOWLEDGMENTS

We thank Doekele Stavenga for introducing us to the computer simulation program.

REFERENCES

Abe, T., Maeda, Y., Iijama, T. (1988). Transient increase of the intracellular Ca^{2+} concentration during chemotactic signal transduction in *Dictyostelium discoideum* cells. *Differentiation* 39, 90–96.

Alcantara, F., and Monk, M. (1974). Signal propagation during aggregation in the slime mould *Dictyostelium discoideum*. *J. Gen. Microbiol.* 85, 321–334.

Bominaar, A.A., Kesbeke, F., and Van Haastert, P.J.M. (1994). Phospholipase C in *Dictyostelium discoideum*, cyclic AMP surface receptor and G-protein-regulated activity in vivo. *Biochem. J.* 295, 181–187.

Bulgakow, R., and Van Haastert, P.J.M. (1983). Isolation and partial characterization of a cyclic GMP-dependent cyclic GMP-specific phosphodiesterase from *Dictyostelium discoideum*. *Biochim. Biophys. Acta* 756, 56–66.

Bumann, J., Wurster, B., and Malchow, D. (1984). Attractant-induced changes and oscillations of the extracellular Ca^{2+} concentration in suspensions of differentiating *Dictyostelium* cells. *J. Cell Biol.* 98, 173–178.

Champeil, P., Combettes, L., Berthon, B., Doucet, E., Orlowski, S., and Claret, M. (1989). Fast kinetics of calcium release induced by *myo*-inositol trisphosphate in permeabilized rat hepatocytes. *J. Biol. Chem.* 264, 17665–17673.

Chang, Y.Y. (1968). Cyclic 3',5'-adenosine monophosphate phosphodiesterase produced by the slime mold *Dictyostelium discoideum*. *Science* 161, 57–59.

Drayer, A.L., Van der Kaay, J., Mayr, G.W., and Van Haastert, P.J.M. (1994). Role of phospholipase C in *Dictyostelium*: formation of inositol 1,4,5-trisphosphate and normal development in cells lacking phospholipase C activity. *EMBO J.* 13, 1601–1609.

Europe-Finner, G.N., and Newell, P.C. (1986a). Inositol 1,4,5-trisphosphate induces calcium release from a non-mitochondrial pool in amoebae of *Dictyostelium*. *Biochim. Biophys. Acta* 887, 335–340.

Europe-Finner, G.N., and Newell, P.C. (1986b). Inositol 1,4,5-trisphosphate and calcium stimulate actin polymerization in *Dictyostelium discoideum*. *J. Cell Sci.* 82, 41–51.

Europe-Finner, G.N., and Newell, P.C. (1987). Cyclic AMP stimulates accumulation of inositol trisphosphate in *Dictyostelium*. *J. Cell Sci.* 87, 221–229.

Gerisch, G., Hülser, D., Malchow, D., and Wick, U. (1975). Cell communication by periodic cyclic-AMP pulses. *Phil. Trans. R. Soc. Lond. B* 272, 181–192.

Goldbeter, A., and Koshland, D.E., Jr. (1982). Simple molecular model for sensing and adaptation based on receptor modification with application to bacterial chemotaxis. *J. Mol. Biol.* 161, 395–416.

Green, A.A., and Newell, P.C. (1975). Evidence for the existence of two types of cAMP binding sites in aggregating cells of *Dictyostelium discoideum*. *Cell* 6, 129–136.

Henderson, E.J. (1975). The cyclic adenosine 3':5'-monophosphate receptor of *Dictyostelium discoideum*. *J. Biol. Chem.* 250, 4730–4736.

Janssens, P.M.W., De Jong, C.C.C., Vink, A.A., and Van Haastert, P.J.M. (1989). Regulatory properties of magnesium-dependent guanylate cyclase in *Dictyostelium discoideum* membranes. *J. Biol. Chem.* 264, 4329–4335.

Knox, B.E., Devreotes, P.N., Goldbeter, A., and Segel, L.A. (1986). A molecular mechanism for sensory adaptation based on ligand-induced receptor modification. *Proc. Natl. Acad. Sci. USA* 83, 2345–2349.

Konijn, T.M. (1972). Cyclic AMP as a first messenger. *Adv. Cyclic Nucleotide Res.* 1, 17–31.

Konijn, T.M., van de Meene, J.G.C., Bonner, J.T., and Barkley, D.S. (1967). The acrasin activity of adenosine-3',5'-cyclic phosphate. *Proc. Natl. Acad. Sci. USA* 58, 1152–1154.

Kuwayama, H., Ishida, S., and Van Haastert, P.J.M. (1993). Non-chemotactic *Dictyostelium* mutants with altered cGMP signal transduction. *J. Cell Biol.* 123, 1453–1462.

Liu, G., and Newell, P.C. (1988). Evidence that cyclic GMP regulates myosin interaction with the cytoskeleton during chemotaxis of *Dictyostelium*. *J. Cell Sci.* 90, 123–129.

McRobbie, S.J., and Newell, P.C. (1984). Chemoattractant-mediated changes in cytoskeletal actin of cellular slime molds. *J. Cell Sci.* 68, 139–151.

Malchow, D., and Gerisch, G. (1974). Short-term binding and hydrolysis of cyclic 3':5'-adenosine monophosphate by aggregating *Dictyostelium* cells. *Proc. Natl. Acad. Sci. USA* 71, 2423–2427.

Malchow, D., Nägele, B., Schwarz, H., and Gerisch, G. (1972). Membrane-bound cyclic AMP phosphodiesterase in chemotactically responding cells of *Dictyostelium discoideum*. *Eur. J. Biochem.* 28, 136–142.

Malchow, D., Böhme, R., and Rahmsdorf, H.J. (1981). Regulation of phosphorylation of myosin heavy chain during the chemotactic response of *Dictyostelium* cells. *Eur. J. Biochem.* 117, 213–218.

Mato, J.M., and Malchow, D. (1978). Guanylyl cyclase activation in response to chemotactic stimulation in *Dictyostelium discoideum*. *FEBS Lett.* 90, 119–122.

- Mato, J.M., Krens, F.A., Van Haastert, P.J.M., and Konijn, T.M. (1977). Cyclic AMP dependent cGMP accumulation in *Dictyostelium discoideum*. Proc. Natl. Acad. Sci. USA 74, 2348–2351.
- Mato, J.M., and Konijn, T.M. (1975). Chemotaxis and binding of cyclic AMP in cellular slime molds. Biochim. Biophys. Acta 385, 173–179.
- Millne, J.L., and Coukell, M.B. (1991). A Ca^{2+} transport system associated with the plasma membrane of *Dictyostelium discoideum* is activated by different chemoattractant receptors. J. Cell Biol. 112, 103–110.
- Okaichi, K., Cubitt, A.B., Pitt, G.S., and Firtel, R.A. (1992). Amino acid substitutions in the *Dictyostelium* $G\alpha$ subunit $G\alpha 2$ produce dominant negative phenotypes and inhibit the activation of adenylyl cyclase, guanylyl cyclase, and phospholipase C. Mol. Biol. Cell 3, 735–747.
- Pan, P., Hall, E.M., and Bonner, J.T. (1972). Folic acid as second chemotactic substance in the cellular slime moulds. Nature (Lond.) New Biol. 237, 181–182.
- Panbacker, R.G., and Bravard, L.J. (1972). Phosphodiesterase in *Dictyostelium discoideum* and the chemotactic response to cyclic adenosine monophosphate. Science 175, 1014–1016.
- Ross, F.M., and Newell, P.C. (1981). Streamers—chemotactic mutants of *Dictyostelium discoideum* with altered cyclic GMP metabolism. J. Gen. Microbiol. 127, 339–350.
- Saran, S., Nakao, H., Tasaka, M., Iida, H., Tsuji, F.I., Nanjundiah, V., and Takeuchi, I. (1994). Intracellular free calcium level and its response to cAMP stimulation in developing *Dictyostelium* cells transformed with jellyfish apoaeguorin cDNA. FEBS Lett. 337, 43–47.
- Schaap, P., and Wang, M. (1986). Interactions between adenosine and oscillatory cAMP signaling regulate size and pattern in *Dictyostelium*. Cell 45, 137–144.
- Streb, H., Irvine, R.F., Berridge, M.J., and Schulz, I. (1983). Release of Ca^{2+} from a non-mitochondrial intracellular store in pancreatic acinar cells by inositol 1,4,5-trisphosphate. Nature 306, 67–69.
- Valkema, R., and Van Haastert, P.J.M. (1992). Inhibition of receptor-stimulated guanylyl cyclase by intracellular calcium ions in *Dictyostelium discoideum* cells. Biochem. Biophys. Res. Commun. 186, 263–268.
- Van Haastert, P.J.M. (1983a). Relationship between adaptation of the folic acid and the cAMP-mediated cGMP response in *Dictyostelium*. Biochem. Biophys. Res. Commun. 115, 130–136.
- Van Haastert, P.J.M. (1983b). Sensory adaptation of *Dictyostelium discoideum* cells to chemotactic signals. J. Cell Biol. 96, 1559–1565.
- Van Haastert, P.J.M. (1987a). Differential effects of temperature on cAMP-induced excitation, adaptation and deadaptation of adenylyl cyclase and guanylate cyclase in *Dictyostelium discoideum*. J. Cell Biol. 105, 2301–2306.
- Van Haastert, P.J.M. (1987b). Kinetics and concentration dependency of cAMP-induced desensitization of a subpopulation of surface cAMP receptors in *Dictyostelium discoideum*. Biochem. 26, 7518–7523.
- Van Haastert, P.J.M., De Vries, M.J., Penning, L.C., Roovers, E., Van der Kaay, J., Erneux, C., and Van Lookeren Campagne, M.M. (1989). Chemoattractant and guanosine 5'-[γ -thio]triphosphate induce the accumulation of inositol 1,4,5-trisphosphate in *Dictyostelium* cells that are labelled with [^3H]inositol by electroporation. Biochem. J. 258, 577–586.
- Van Haastert, P.J.M., De Wit, R.J.W., Janssens, P.M.W., Kesbeke, F., and DeGoede, J. (1986). G-protein-mediated interconversions of cell-surface cAMP receptors and their involvement in excitation and desensitization of guanylate cyclase in *Dictyostelium discoideum*. J. Biol. Chem. 261, 6904–6911.
- Van Haastert, P.J.M., and Van der Heyden, P.R. (1983). Excitation, adaptation and deadaptation of the cAMP-mediated cGMP response in *Dictyostelium discoideum*. J. Cell Biol. 96, 347–353.
- Van Haastert, P.J.M., Van Lookeren Campagne, M.M., and Ross, F.M. (1982). Altered cGMP-phosphodiesterase activity in chemotactic mutants of *Dictyostelium discoideum*. FEBS Lett. 147, 149–152.
- Van Haastert, P.J.M., Van Lookeren Campagne, M.M., and Kesbeke, F. (1983). Multiple degradation pathways of chemoattractant-mediated cGMP accumulation in *Dictyostelium*. Biochim. Biophys. Acta 756, 67–71.
- Van Haastert, P.J.M., and Van Lookeren Campagne, M.M. (1984). Transient kinetics of a cGMP-dependent cGMP-specific phosphodiesterase from *Dictyostelium discoideum*. J. Cell Biol. 98, 709–716.
- Van Lookeren Campagne, M.M., Erneux, C., Van Eijk, R., and Van Haastert, P.J.M. (1988). Two dephosphorylation pathways of inositol 1,4,5-trisphosphate in homogenates of the cellular slime mould *Dictyostelium discoideum*. Biochem. J. 254, 343–350.