

A new ATP-independent DNA endonuclease from *Schizosaccharomyces pombe* that recognizes cyclobutane pyrimidine dimers and 6-4 photoproducts

Krista K. Bowman, Khalifah Sidik¹, Colin A. Smith², John-Stephen Taylor², Paul W. Doetsch and Greg A. Freyer^{1,*}

Departments of Biochemistry and Radiation Oncology, Emory University School of Medicine, Rollins Research Center, Atlanta, GA 30322, ¹Center for Radiological Research, Columbia University College of Physicians and Surgeons, 630 W. 168 Street, New York, NY 10032 and ²Department of Chemistry, Washington University, St Louis, MO 63130, USA

Received May 12, 1994; Revised and Accepted July 6, 1994

ABSTRACT

We have discovered a new DNA endonuclease in the fission yeast *Schizosaccharomyces pombe* which recognizes cyclobutane pyrimidine dimers and (6-4) pyrimidine-pyrimidone photoproducts. *S.pombe* DNA endonuclease (SPDE) catalyzes a single ATP-independent incision immediately 5' to the UV photoproduct and generates termini containing 3' hydroxyl and 5' phosphoryl groups. Based on these properties, we propose that SPDE may function in a DNA repair capacity, representing the initial recognition/cleavage step of a DNA excision repair pathway.

INTRODUCTION

Prokaryotic and eukaryotic cells contain many nucleases that participate in cellular processes such as DNA replication, transcription, recombination, and repair (1). Endonucleases, in particular, can hydrolyze DNA at locations of specific DNA sequences, modified DNA bases, mismatched duplex DNA, or regions of duplex DNA containing structural distortions (1, 2, 3). Assigning a physiological role for any one of these processes to a specific endonuclease, in the absence of genetic information, is problematic. Characterizing the general properties of an endonuclease as well as biochemically analyzing the incision event that it catalyzes, however, provides a starting point for the elucidation of the biological function of the endonuclease and the DNA processing pathway in which it acts (1, 4).

UV light induces the formation of a variety of photoproducts in DNA, the most predominant of which are cyclobutane pyrimidine dimers (CPDs) and 6-4'-[pyrimidine-2'-one] pyrimidine photoproducts (6-4 PPs) (5, 6, 7). These DNA lesions can be processed by several cellular DNA repair systems, making use of different endonucleolytic activities (1, 3, 8). In addition, endonucleases involved in genetic recombination as well as single strand-specific endonucleases may also incise DNA in response

to UV photoproducts (1, 9, 10, 11). We have recently developed an *in vitro* DNA repair system using whole cell extracts of *S.pombe* which measures the incision and repair synthesis of DNA exposed to UV light or ionizing radiation. DNA repair synthesis of the damaged DNA was shown to be ATP-dependent, however, the UV light-dependent incision of plasmid DNA did not require ATP (12). It is well-documented that the incision step catalyzed by the proteins of the nucleotide excision repair complex in both *E.coli*, yeast, and humans requires ATP (13, 14, 15). The ATP-independent incision of UV-irradiated DNA by these cell extracts suggests that *S.pombe* possesses both a nucleotide excision repair system and an additional UV photoproduct-recognizing endonuclease.

Here we describe the initial characterization of *S.pombe* DNA endonuclease (SPDE), an enzyme that recognizes and cleaves DNA at CPDs and 6-4PPs, the two major UV light-induced DNA lesions. SPDE catalyzes a single ATP-independent incision of DNA directly 5' to the bipyrimidine UV photoproduct. The resulting DNA scission products contain 5' terminal phosphoryl groups and 3' terminal hydroxyl groups. The properties of SPDE are consistent with a role in DNA excision repair, although it is also conceivable that it functions in other DNA processing events.

MATERIALS AND METHODS

SPDE preparation

Cell-free extracts (fraction I) of wild type (strain 972) and *rad13* (*rad13A* (H/1)) *S.pombe* cells were prepared as previously described (16), dialyzed in 20 mM HEPES–KOH, pH 7.6, 1 mM phenylmethanesulfonyl fluoride, 10% glycerol (buffer A) including 0.2 M NaCl and applied to a DEAE cellulose column equilibrated in the same buffer. Unbound proteins, eluted with buffer A containing 0.2 M NaCl (fraction II), were dialyzed in buffer A containing 0.05 mM NaCl and fractionated over a Mono

*To whom correspondence should be addressed

S/P column eluted with a 0.05–1.0 M NaCl gradient in buffer A. SPDE activity was monitored by following the CPD-specific cleavage of the 5' end-labeled duplex CPD 49mer as shown in Figure 2A. The SPDE-containing fractions were pooled (fraction III) and used for all experiments in this study with the exception of that presented in Figure 1. SPDE (fraction I) was used to demonstrate the UV photoproduct-specific ATP-independent DNA nicking activity in *S.pombe* presented in Figure 1.

Damaged DNA substrate preparation

Supercoiled pUC18 DNA was prepared by banding twice on CsCl/ethidium bromide density gradients as previously described (16). The plasmid DNA was irradiated with 250 J/m² of UV light (254 nm), the pyrimidine photohydrates were removed by *E.coli* endonuclease III-treatment, and the plasmid DNA was recovered by sucrose gradient centrifugation as previously described (16).

A set of duplex 49 bp oligonucleotides with the following sequence were synthesized and characterized as described (17):

5' AGCTACCATGCCTGCACGAA_{xy}AAGCAATTCGTAATCATGGTCAT-
AGCT 3' strand A
3' GATGGTACGGACGTGCTTAATTCGTTAAGCATTAGTACCAGTATC-
GACT 5' strand B

Positions 21 and 22 on strand A (x and y) correspond to either a cis-syn cyclobutane dimer (CPD 49mer), a (6-4) pyrimidine-pyrimidone (TT) photoproduct (6-4 PP 49mer), or two adjacent thymines (N 49mer) as an undamaged control.

Strand A was 5' end-labeled as described (18). Strand A (5 pmoles) was 3' end-labeled with 13 units of terminal deoxynucleotide transferase (TdT, Promega) and 50 μ Ci of [α -³²P] dideoxyATP in 100 mM sodium cacodylate, pH 6.8, 1 mM CoCl₂, 0.1 mM dithiothreitol (DTT), 0.1 mg/mL bovine serum albumin (BSA) for 30 min. at 37°C (10 μ L final volume) as specified by the supplier. 5' or 3' end-labeled strand A was annealed to strand B in 10 mM Tris-HCl, pH 8.0, 1 mM EDTA, 10 mM MgCl₂ by slow (3–4 hr.) cooling from 72°C (10 min. incubation) to 25°C.

Enzyme and chemical treatments of DNA

For SPDE digestions of pUC18 DNA, 0.5 μ g of plasmid DNA was incubated with SPDE (fraction I, 100 μ g) in 45 mM HEPES-KOH, pH 7.8, 70 mM KCl, 7.4 mM MgCl₂, 0.9 mM DTT, 0.4 mM EDTA (50 μ L final volume) for 0, 15, 30, and 60 min. at 30°C. The incubations were terminated by freezing and by the addition of 20 mM EDTA. DNA samples were incubated with 25 μ g pancreatic RNase (Boehringer Mannheim) at 37°C for 15 min. prior to the addition of SDS to a final concentration of 0.4%. 25 μ g proteinase K (Boehringer Mannheim) was added and the samples incubated at 50°C for 30 min. The samples were placed on ice for 20 min., the precipitate removed by centrifugation, and the DNA precipitated with an equal volume of isopropanol. The precipitated DNA was washed with 70% ethanol, dried, and dissolved in 10 μ L TE buffer (10 mM Tris-HCl, pH 8.0, 1 mM EDTA). The nicked plasmid DNA was analyzed by 1% agarose gel electrophoresis with ethidium bromide.

For SPDE digestions of end-labeled 49mer substrates, approximately 0.01 pmol of 5' end-labeled CPD 49mer or 6-4 PP 49mer were incubated with SPDE (fraction III, 10 μ g) in 20 mM HEPES-KOH, 25 mM NaCl, pH 7.6, 10 mM MgCl₂ (100 μ L final volume) for 10 min. at 37°C. For T4 endo V

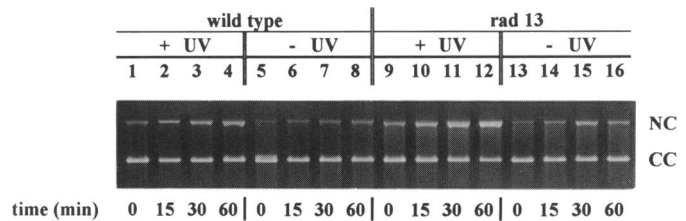

Figure 1. *S.pombe* cell-free extracts nick plasmid DNA in a UV-specific, ATP-independent manner. 0.05 μ g UV-irradiated plasmid DNA, from which the pyrimidine hydrates had been removed (lanes 1–4 and 9–12) and undamaged plasmid DNA (lanes 5–8 and 13–16) were incubated for the specified time (min.) with SPDE (fraction I) isolated from wild type cells (lanes 1–8) and SPDE (fraction I) isolated from *rad13* cells (lanes 9–16). The reaction products were analyzed on 1% agarose gels containing ethidium bromide as described (Materials and Methods). NC indicates the mobility of the nicked-circular plasmid DNA and CC indicates the mobility of the closed circular plasmid DNA.

digestions, 0.01 pmol of 5' end-labeled CPD 49mer was incubated with 7.5 ng of purified T4 endo V in 10 mM Tris-HCl, pH 8.0, 10 mM NaCl, 1 mM EDTA (100 μ L final volume) for 10 min. at 37°C. The reaction products were processed by extracting with an equal volume of phenol-chloroform-isomyl alcohol (25–24–1/v-v-v), ethanol precipitated, and analyzed by 15–20% denaturing (7 M urea) polyacrylamide gel electrophoresis as previously described (19). The Maxam and Gilbert base-specific chemical cleavage reaction products (20) were run in adjacent lanes to the DNA samples under study for comparison.

Hot alkali reactions for the cleavage of DNA at sites of 6-4 PPs were carried out with 50–100 μ L of 1 M piperidine at 90°C for 10–25 min. followed by ethanol precipitation of the DNA. Photoreactivation of CPDs was performed essentially as previously described (21). DNA, either prior to or following repair enzyme treatment, was incubated with *E.coli* DNA photolyase (DPL; 0.2 μ g) directly under a fluorescent light for 1 hour at 25°C and processed and analyzed as described above.

To test for the presence of 5' phosphoryl groups, ethanol precipitated SPDE- or T4 endo V-digested 3' end labeled DNA samples were reacted with 1 unit of calf intestinal phosphatase (CIP, Boehringer Mannheim) in 50 mM Tris-HCl, pH 8.0, 0.1 mM EDTA (10 μ L final volume) for 15 min. at 37°C. Samples were processed as specified by the supplier, followed by electrophoresis as described above. In addition, ethanol precipitated SPDE- and T4 endo V-digested 3' end-labeled DNA samples were reacted under conditions for the phosphorylation of 5' hydroxyl termini with 20 units of T4 polynucleotide kinase (PNK) and 50 pmols ATP as previously described (18). PNK-reacted samples were processed and analyzed as described above.

To determine the chemical nature of the 3' termini of repair enzyme-mediated DNA cleavage products, 5' end-labeled DNA fragments were incubated for 1 hr. at 37°C with 20 units of PNK (possessing 3' phosphatase activity) in the absence of ATP under the following conditions in a final volume of 10 μ L: 25 mM 2-[N-morpholino]ethanesulfonic acid (MES), pH 6.0, 8 mM MgCl₂, 1.5 mM ammonium acetate, and 5 mM 2-mercaptoethanol (22). In addition, 5' end-labeled DERE-generated DNA cleavage products were incubated with TdT as described above for 3' end-labeling except that unlabeled dideoxy-ATP (20 μ M) was used in place of [α -³²P] dideoxyATP in a final volume of 10 μ L. Samples were processed and analyzed as described above.

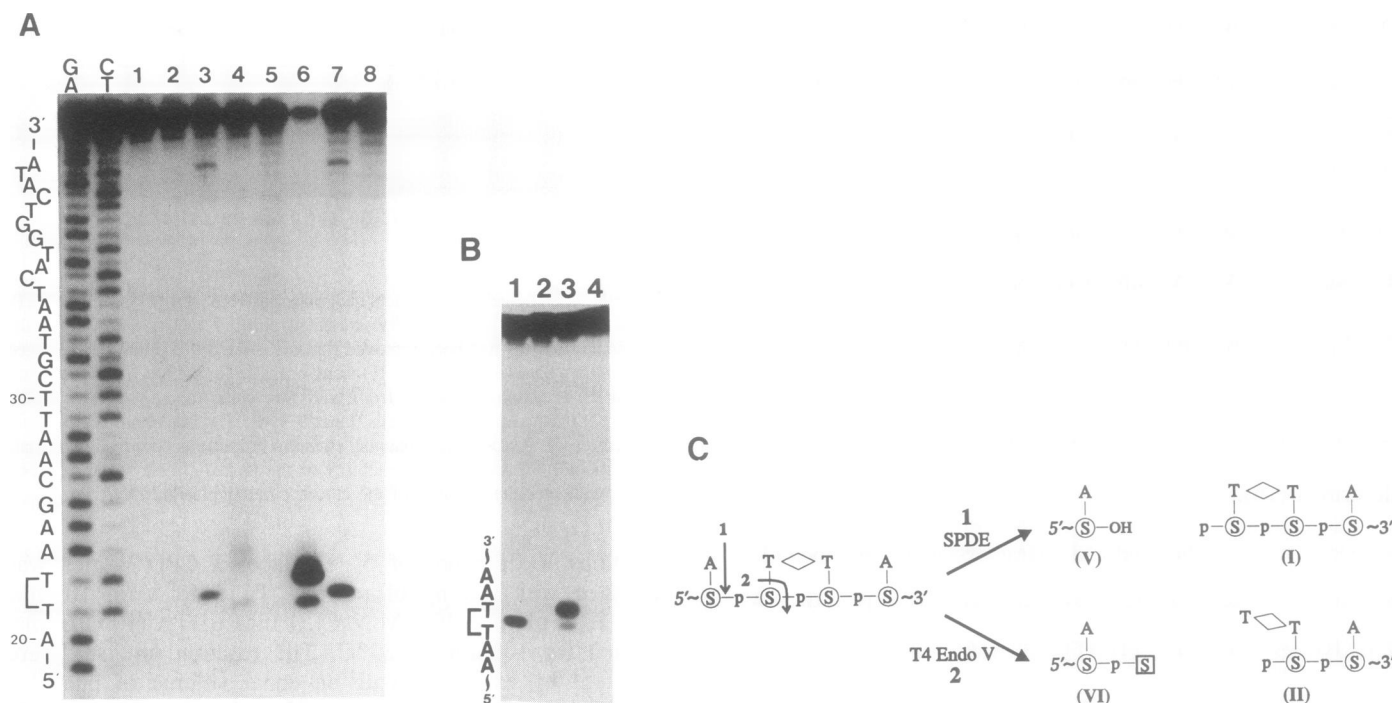

Figure 2. (A) SPDE incises duplex oligonucleotides directly 5' to CPDs and 6-4 PPs. 5' end-labeled duplex CPD 49mer (lanes 5–8) and 6–4 PP 49mer (lanes 1–4) were incubated with SPDE (fraction III) (lanes 3 and 7), T4 endo V (lanes 2 and 6), subjected to hot alkali treatment (lanes 4 and 5), or left untreated (lanes 1 and 8) and the DNA scission products analyzed on a 15% denaturing polyacrylamide DNA sequencing gel. The Maxam and Gilbert purine (GA) and pyrimidine (CT) DNA sequencing reaction products were run in the left-hand lanes. The sequence of the substrate DNA, numbered from the 5' terminus, is displayed. Brackets around T21–T22 denote the photoproduct site. (B) SPDE-mediated DNA cleavage depends on the presence of a photoproduct. 5' end-labeled CPD 49mer was treated with *E. coli* DNA photolyase and photoreactivating light (lanes 2 and 4) to reverse the CPDs or was left untreated (lanes 1 and 3) and then incubated with either SPDE (lanes 1 and 2) or T4 endo V (lanes 3 and 4). The reactions were analyzed on a DNA sequencing gel as in (A). (C) Mode of DNA strand scission by SPDE and T4 endo V. DNA cleavage reactions are depicted for the T21–T22 site on duplex CPD 49mer strand A by SPDE (arrow 1, 5' direct nuclease) to generate DNA fragments containing 3' hydroxyl (product V) and 5' phosphoryl (product I) termini or by T4 endo V (arrow 2, N-glycosylase/AP lyase) to generate DNA fragments containing 3' 4-hydroxy-*trans*-2-pental termini (product IV, β -elimination) and 5' phosphoryl (product II) termini. For simplicity, complementary strand B is not shown.

Ethanol precipitated SPDE- and T4 endo V-generated DNA cleavage products were incubated with 3 units of T4 DNA polymerase (Promega) under 3' to 5' exonuclease conditions (33 mM Tris–Acetate, pH 8.0, 66 mM potassium acetate, 10 mM magnesium acetate, 5 mM DTT, 0.1 mg/mL bovine serum albumin, in the absence of dNTPs) in a final volume of 20 μ L as previously described (19). The exonuclease-reacted samples were processed and analyzed as described above.

RESULTS

Extracts of *S. pombe* were prepared from both wild type and nucleotide excision repair-deficient *rad13* cells. The cell-free extracts were incubated for various times with covalently closed circular plasmid DNA that had been left undamaged or had been UV-irradiated (250 J/m²) and subjected to treatment with *E. coli* endonuclease III to remove the pyrimidine photohydrates. The products were analyzed by agarose gel electrophoresis. The conversion to the nicked circular form of the UV-irradiated plasmid and not the undamaged plasmid by the cell-free extracts demonstrates that *S. pombe* contains a DNA endonuclease specific for the major UV photoproducts and not pyrimidine photohydrates (Figure 1). Treatment of the extracts with hexokinase and glucose to deplete residual ATP (16) had no effect on the UV-specificity or the extent of the DNA incision observed (data

not shown), indicating that the DNA endonuclease is ATP-independent.

A series of experiments were carried out to determine if the endonuclease, which we termed *S. pombe* DNA endonuclease (SPDE), recognized either CPDs or 6-4 PPs. SPDE (fraction I) was incubated with 5' end-labeled 49 bp oligonucleotides containing a single CPD or 6-4PP at nucleotide site T21–T22 (CPD 49mer and 6-4 PP 49mer). The SPDE-generated DNA cleavage products were compared to those produced by hot alkali-induced DNA cleavage and by the DNA repair enzyme T4 endo V. Treatment of the 6-4 PP 49mer with hot alkali resulted in non-quantitative cleavage of the DNA, producing several DNA strand scission products containing different 3' termini as reported previously (23). T4 endo V is a CPD-specific DNA repair enzyme that removes CPDs through a combined N-glycosylase/AP lyase activity, producing one DNA fragment containing a 5' terminal phosphoryl group and another containing a 3' terminal 4-hydroxy-*trans*-2-pental residue (24, 25). Figure 2A demonstrates that SPDE incises both CPD and 6-4 PP-containing DNA directly 5' to the lesion, generating products with electrophoretic mobilities slightly slower than the Maxam and Gilbert base-specific chemical cleavage product of the 5' pyrimidine of the photoproduct. The SPDE-generated DNA scission product migrates to an intermediate position between the major T4 endo V-generated scission product (β -elimination), containing a 3'

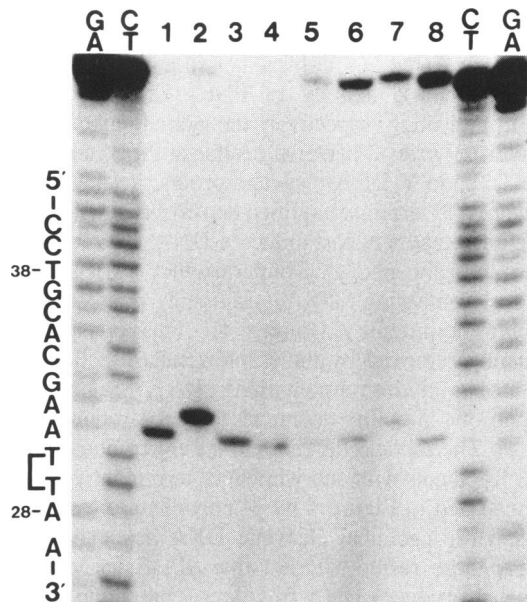
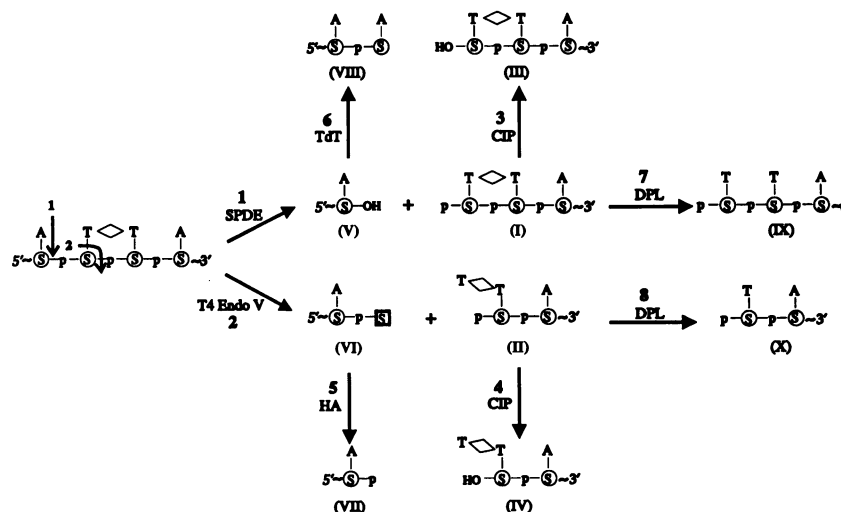

Figure 3. SPDE generates DNA cleavage products containing 5' terminal phosphoryl groups. 3' end-labeled CPD 50mer was incubated with SPDE (lanes 5–8) and T4 endo V (lanes 1–4), and the DNA cleavage products were subsequently treated with hot alkali (lanes 4 and 5), PNK and ATP (lanes 3 and 6), CIP (lanes 2 and 7), or left untreated (lanes 1 and 8). The resulting DNA fragments generated were analyzed on a 20% denaturing polyacrylamide DNA sequencing gel. The Maxam and Gilbert purine (GA) and pyrimidine (CT) DNA sequencing reaction products were run in the left-hand and right-hand lanes. The sequence of the substrate DNA, numbered from the 3' terminus, is displayed and the brackets around T29–T30 denote the CPD site.

terminal 4-hydroxy-*trans*-2-pentalen, and the minor product (β - δ -elimination) containing a 3' terminal phosphoryl group. This migration pattern is consistent with SPDE generating a DNA cleavage product containing a 3' terminal hydroxyl group. Reversal of the CPD by *E. coli* DNA photolyase treatment prior to incubation with SPDE and T4 endo V resulted in the complete elimination of DNA cleavage by either enzyme (Figure 2B) and indicates that DNA cleavage by SPDE is entirely dependent on the presence of a photoproduct. Thus SPDE recognizes both CPDs and 6-4 PPs in DNA and incises the phosphodiester bond immediately 5' to the photoproduct (Figure 2C) to generate a 3' terminal hydroxyl group-containing product (product V) and a 5' terminal phosphoryl group-containing product (product I).

To confirm the nature of the SPDE-mediated DNA strand scission, experiments were carried out to examine the 5' and 3' terminus of the SPDE-generated DNA cleavage products individually. 3' End-labeled CPD 50mer (CPD 49mer plus [³²P]-dideoxyAMP) was digested with SPDE and T4 endo V, and the respective DNA cleavage products were subjected to further chemical or enzymatic treatment to establish the chemical nature of the 5' terminus of the DNA cleavage products (Figure 3). The SPDE and T4 endo V-generated cleavage products are nearly identical, with the major product of T4 endo V (Scheme I, product VI) migrating only slightly faster than the SPDE product (product V). The electrophoretic mobility of the SPDE-mediated product is identical to that of the base-specific chemical cleavage product of nucleotide A31, located immediately 5' to the photoproduct. Treatment of both the SPDE and T4 endo V-generated products with calf intestinal phosphatase (CIP) to remove a terminal phosphoryl group and produce a hydroxyl-containing terminus (Scheme I, products III and IV, respectively) (26), resulted in DNA fragments whose electrophoretic mobilities



Scheme 1. DNA cleavage products following subsequent chemical and enzymatic treatments to establish chemical nature of termini. The SPDE and T4 endo V-generated DNA cleavage products, products V and I and products VI and II, respectively, are described in the legend in Figure 1C. Subsequent treatment of 3' end-labeled products I and II with CIP (reactions 3 and 4) produces DNA fragments containing 5' terminal hydroxyl groups (products III and IV). Treatment of products I and II with *E. coli* DNA photolyase and visible light (DPL; reactions 7 and 8) reverses the CPDs to produce products IX and X, respectively. Hot alkali treatment of the 5' end-labeled T4 endo V-generated product VI (reaction 5) results in a DNA fragment with a 3' terminal phosphoryl group (product VII). The subsequent treatment of SPDE-generated 5' end-labeled product V with TdT and dideoxyATP (reaction 6) results in the production of a DNA fragment containing a single 3' terminal dideoxyAMP residue (product VIII). For simplicity, complementary strand B is omitted.

were retarded as compared to those without CIP-treatment (Figure 3). The removal of a 5' terminal phosphate from a DNA fragment of this size is expected to retard its electrophoretic mobility (27), therefore suggesting that the SPDE cleavage product contains a 5' terminal phosphoryl group. Furthermore, subsequent treatment of the SPDE and T4 endo V cleavage products with polynucleotide kinase (PNK) and ATP to add a phosphoryl group to 5' hydroxyl-containing termini or with hot alkali to remove 4-hydroxy-*trans*-2-pentalenol residues (28) had no effect on the electrophoretic mobility of the cleavage products (Figure 3). Together, these results suggest that the SPDE incises DNA to produce a strand scission product containing a 5' terminal phosphoryl group.

To further characterize the nature of SPDE-mediated DNA strand scission, 5' end-labelled CPD 49mer was incubated with SPDE and T4 endo V, and the resulting DNA scission products were subjected to additional chemical or enzymatic treatments (Figure 4). The SPDE cleavage product was treated with terminal deoxynucleotidyl transferase (TdT) and dideoxyATP (ddATP), a treatment that results in the non-templated addition of ddAMP to a 3' hydroxyl-containing terminus (29). This treatment produced a DNA fragment (Scheme I, product VIII) that migrates at a position one nucleotide longer than the SPDE-generated

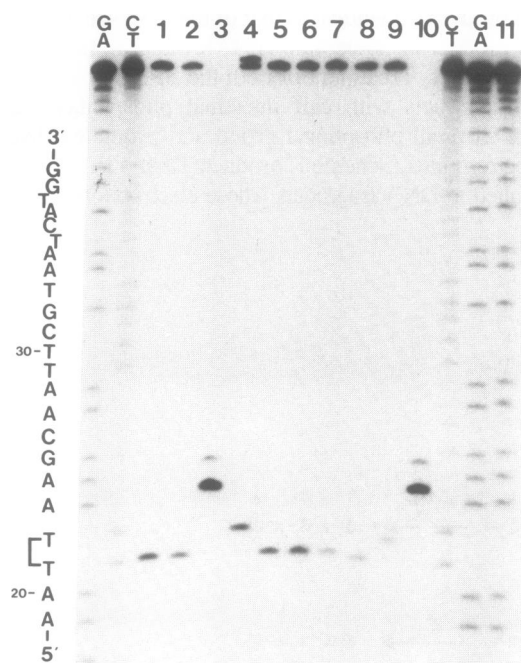

Figure 4. SPDE generated DNA cleavage products containing 3' terminal hydroxyl groups. 5' end-labelled CPD 49mer was incubated with SPDE (lanes 1–6) and T4 endo V (lanes 7–10), and the DNA cleavage products were subsequently treated with hot alkali (lanes 2 and 8), 3' exonuclease (lanes 3 and 10), TdT and dideoxyATP (lane 4), PNK 3' phosphatase (lane 5), hot alkali followed by PNK 3' phosphatase (lane 7), or left untreated (lanes 1, 6, 9). The resulting DNA fragments were analyzed on a 20% denaturing polyacrylamide DNA sequencing gel. The Maxam and Gilbert purine (GA) and pyrimidine (CT) DNA sequencing reaction products were run in the left-hand and right-hand lanes. The sequence of the substrate DNA, numbered from the 5' terminus, is displayed and the brackets around T21–T22 denote the photoproduct site. The purine-specific DNA sequencing reaction products (GA) were subsequently treated with PNK 3' phosphatase as a positive control (lane 11) to confirm the expected difference in electrophoretic mobilities of DNA fragments of the same size with and without a 3' terminal phosphoryl group.

product, thus indicating the presence of a 3' terminal hydroxyl group on the SPDE cleavage product (Figure 4). In addition, the SPDE-generated DNA strand scission product is resistant to the 3' phosphatase activity of PNK (22) and to hot alkali treatment, indicating respectively the lack of a phosphoryl group or a 4-hydroxy-*trans*-2-pentalenol residue at the 3' terminus (Figure 4). The T4 endo V DNA cleavage product (Scheme I, product VI) contains a 3' terminal modified deoxyribose that was removed by hot alkali treatment to produce a DNA fragment containing a 3' terminal phosphoryl group (product VII). The resulting phosphoryl-containing DNA fragment possesses a faster electrophoretic mobility (Figure 4). This phosphate can be subsequently removed by the 3' phosphatase activity of PNK, to produce a hydroxyl-containing DNA fragment with an electrophoretic mobility identical to that produced by SPDE (Figure 4). The subtle differences in the electrophoretic mobilities of DNA fragments with and without 3' terminal hydroxyl groups is demonstrated in Figure 4 by 3' phosphatase treatment of the purine-specific chemical cleavage DNA sequencing products. Together, these results suggest that SPDE incises DNA in a manner that produces DNA fragments containing a 3' terminal hydroxyl group.

The SPDE and T4 endo V-generated DNA cleavage products were also digested with the 3' to 5' exonuclease activity (3' exo) of T4 DNA polymerase, and this treatment resulted in the loss of the 21mer product bands (Figure 4). This result suggests that the SPDE and T4 endo V products do not contain the CPD, as this 3' exonuclease is known to be blocked by CPDs (19). The new products, migrating to a position one to two nucleotides longer than the SPDE or T4 endo V-generated products, are a result of the blocking of the exonuclease-mediated digestion of the unreacted substrate 49mer when it encounters the CPD.

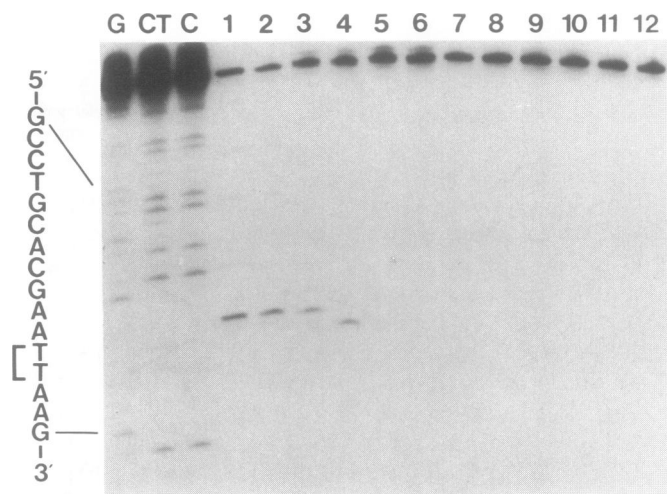

Figure 5. SPDE does not possess a CPD-specific N-glycosylase activity. 3' end-labelled duplex CPD 50mer (lanes 1–6) and N 50mer (lanes 7–12) were incubated with SPDE (fraction III) (lanes 1–2 and 7–8), T4 endo V (lanes 3–4 and 9–10), or left untreated (lanes 5–6 and 11–12). The strand scission products were subsequently treated with (lanes 2, 4, 6, 8, 10, 12) or without (lanes 1, 3, 5, 7, 9, 11) *E. coli* DNA photolyase in the presence of visible light to reverse the CPDs. The DNA strand scission products were analyzed on a 15% denaturing polyacrylamide DNA sequencing gel. Guanine (G) and pyrimidine (CT and C) chemical cleavage DNA sequencing products were run in the left-hand lanes. The sequence of the substrate DNA, numbered from the 3' terminus, is displayed. Brackets around T29–T30 denote the CPD site.

Therefore, these results are consistent with SPDE incising DNA at sites of CPDs immediately 5' to the lesion, producing DNA cleavage products containing a 5' terminal phosphoryl group and a 3' terminal hydroxyl group.

The above results demonstrating that hot alkali treatment has no effect on the SPDE-generated DNA cleavage products resulting from reactions with either 5' or 3' end-labeled CPD-containing DNA substrate, indicate that SPDE does not possess a CPD-specific N-glycosylase activity. N-glycosylase activity would result in the production of an abasic site, which would have been cleaved under the conditions of the hot alkali treatment (28). To further confirm the suspected lack of N-glycosylase activity, we performed an electrophoretic mobility shift experiment utilized previously to demonstrate the CPD-specific N-glycosylase activity of the base excision repair enzymes T4 endo V and yeast pyrimidine dimer endonuclease (YPDE) (30). SPDE and T4 endo V were incubated with 3' end-labeled CPD 50mer and the products subsequently treated with *E. coli* DNA photolyase to reverse the cyclobutane ring of the CPD and release a free thymine base (Scheme I, products IX and X). The conversion to a faster migrating DNA fragment upon DNA photolyase treatment of the T4 endoV-mediated DNA cleavage product (Figure 5) is indicative of its CPD-specific N-glycosylase activity (30). DNA photolyase treatment of the SPDE-generated DNA cleavage product has no effect on its electrophoretic mobility (Figure 5), verifying that SPDE does not cleave the N-glycosidic bond of the CPD.

DISCUSSION

We have demonstrated that *S. pombe* contains an activity (SPDE) that recognizes and cleaves DNA at sites of the two major UV light-induced DNA photoproducts, CPDs and 6-4 PPs. SPDE incises the DNA immediately 5' to the UV photoproduct to produce DNA cleavage products that contain a 5' terminal phosphoryl group and 3' terminal hydroxyl group. Unlike the CPD-specific base excision repair enzymes T4 endo V and YPDE, SPDE does not cleave the N-glycosidic bond of the 5' or the 3' pyrimidine of the dimer. SPDE is a 120 kDa protein (gel filtration analysis), requires divalent cations for catalysis, and is ATP-independent. Its substrate specificity has not been extensively surveyed, however, duplexes containing abasic sites and pyrimidine hydrates are not cleaved (unpublished results), suggesting that a certain degree of helix distortion may be required for recognition. SPDE appears to be specific for double stranded DNA, as no conditions have yet been established under which SPDE incises single stranded CPD 49mer oligonucleotide substrate (not shown). Because partially purified SPDE preparations were used in these experiments, we cannot exclude the possibility that two different proteins with identical cleavage mechanisms are involved in individual incision events at sites of CPDs and 6-4 PPs. We feel that this is unlikely, however, since SPDE preparations that have undergone subsequent purification steps retain activity against both types of UV photoproducts (unpublished results). The properties of SPDE indicate that it could be exploited for use as a tool for the analysis of UV-damaged DNA.

The single SPDE-mediated incision immediately 5' to the site of damage, leaving 5' and 3' termini compatible for processing by other components of the cellular DNA excision repair machinery, leads us to propose that SPDE may perform a DNA

repair function in *S. pombe*. However, it should be noted that our results do not exclude other potential functions for SPDE, such as a role in recombination or other DNA processing events. We are currently carrying out genetic studies to determine the physiological role of SPDE. Should SPDE prove to be involved in DNA repair, it would represent a new class of DNA excision repair enzymes that is mechanistically distinct from those involved in the nucleotide excision repair (NER) and base excision repair (BER) pathways. The absence of an N-glycosylase activity separates SPDE from BER enzymes such as T4 endo V and YPDE. The single ATP-independent DNA incision event also distinguishes SPDE from NER enzymes such as those involved in the *E. coli* UvrABC excision nuclease system.

ACKNOWLEDGEMENTS

We would like to thank R.S.Lloyd and A.Sancar for their gifts of T4 endonuclease V and *E. coli* DNA photolyase. This work has been supported by grants from NIH to P.W.D. (CA42608 and CA55896) and to J.-S.T. (CA40463) and to G.F. (CA12536) and from the American Cancer Society to P.W.D. (NP806). P.W.D. is the recipient of a Research Career Development Award from the NIH (CA 01441).

REFERENCES

- Linn, S.M., Lloyd, R.S., and Roberts, R.J. (1993) *Nucleases*, Second Edition. Cold Spring Harbor Laboratory Press, Cold Spring Harbor, NY.
- Strickland, J.A., Marzilli, L.M., Puckett, J.M., and Doetsch, P.W. (1991) *Biochemistry*, **30**, 9749-9756.
- Friedberg, E.C. (1985) *DNA Repair*. W.H. Freeman, New York.
- Linn, S.M. and Roberts, R.J. (1982) *Nucleases*. Cold Spring Harbor Laboratory, Cold Spring Harbor, NY.
- Harm, W. (1980) *Biological Effects of Radiation*. Cambridge University Press, Cambridge.
- Rahn, R.O. and Patrick, M.H. (1976) In Wang, S. (ed.), *Photochemistry and Photobiology of Nucleic Acids*. Academic Press, New York, Vol. 2, pp 97-145.
- Witkin, E.M. (1976) *Bacteriol. Rev.*, **40**, 869-907.
- Van Houten, B. (1990) *Microbiol. Rev.*, **54**, 18-51.
- Doetsch, P.W., McCray Jr., W.H., Lee, K., Bettler, D.R., and Valenzuela, M.R.L. (1988) *Nucleic Acids Res.*, **16**, 6935-6952.
- Ganesan, A.K. (1974) *J. Mol. Biol.*, **87**, 103-119.
- Cox, B.S. (1978) In Hanawalt, P.C., Friedberg, E.C., and Fox, C.F. (eds.), *DNA Repair Mechanisms*. Academic Press, New York, 429-435.
- Todo, T., Takemori, H., Ryo, H., Ihara, M., Matsunaga, T., Nikaido, O., Sato, K., and Nomura, T. (1993) *Nature*, **361**, 372-374.
- Orren, D.K., and Sancar, A. (1990) *J. Biol. Chem.*, **265**, 15796-15803.
- Wang, Z., Wu, X., and Friedberg, E.C. (1993) *Proc. Natl. Acad. Sci., USA*, **90**, 4907-4911.
- Kaufmann, W.K. and Briley, L.P. (1990) *Carcinogenesis*, **11**, 15-19.
- Sidik, K., Lieberman, H.B., and Freyer, G.A. (1992) *Proc. Natl. Acad. Sci., USA*, **89**, 12112-12116.
- Smith, C.A. and Taylor, J.-S. (1993) *J. Biol. Chem.*, **268**, 11143-11151.
- Sambrook, J., Fritsch, E., and Maniatis, T. (1989) *Molecular Cloning: A Laboratory Manual* (ed. 2). Cold Spring Harbor University Press, Cold Spring Harbor.
- Doetsch, P.W., Chan, G.L., and Haseltine, W.A. (1985) *Nucleic Acids Res.*, **13**, 3285-3304.
- Maxam, A.M. and Gilbert, W. (1980) *Meth. Enzymol.*, **65**, 499-599.
- Sancar, A., Smith, F.W., and Sancar, G.B. (1984) *J. Biol. Chem.*, **259**, 6028-6032.
- Richardson, C.C. (1981) In Boyer, P.D. (ed.), *The Enzymes*. Academic Press, New York, pp 299.
- Franklin, W.A., Lo, K.M., and Haseltine, W.A. (1982) *J. Biol. Chem.*, **257**, 13535-13543.
- Manoharan, M., Ransom, S.C., Mazumder, A., and Gerlt, J.A. (1988) *J. Am. Chem. Soc.*, **110**, 1622-X.

25. Demple, B. and Linn, S. (1980) *Nature*, **287**, 203–207.
26. Tabor, S. In Ausubel, F.M., Brent, R.E., Kingston, D.D., Morre, J.G., Seidman, J.A., and Struhl, K. (eds.), *Current Protocols in Molecular Biology*. Greene Publishing Associates and Wiley-Interscience, New York, pp. 3.5.9–3.5.10.
27. Tapper, D.P. and Clayton, D. (1981) *Nuc. Acids. Res.*, **9**, 6787–6794.
28. Grossman, L. and Grafstrom, R. (1982) *Biochimie*, **64**, 577–580.
29. Chang, L.M.S. and Bollum, F.J. (1971) *J. Biol. Chem.*, **246**, 536–542.
30. Hamilton, K.K., Kim, P.M.H., and Doetsch, P.W. (1992) *Nature*, **365**, 725–728.