

## *lcrH*, a Gene Necessary for Virulence of *Yersinia pestis* and for the Normal Response of *Y. pestis* to ATP and Calcium

STUART B. PRICE AND SUSAN C. STRALEY\*

Department of Microbiology and Immunology, Chandler Medical Center, University of Kentucky,  
Lexington, Kentucky 40536

Received 25 August 1988/Accepted 18 January 1989

We are investigating the functions of the three proteins encoded by the V operon (*lcrGVH*) of the low-calcium response virulence plasmid pCD1 of *Yersinia pestis* KIM5. The purpose of this study was to define the role of the 18-kilodalton protein encoded by *lcrH*, the third gene of the V operon. Using marker exchange mutagenesis, we constructed a *Y. pestis* mutant that failed to express the LcrH protein. This LcrH<sup>-</sup> mutant was "ATP blind" in that it failed to show altered growth and V-antigen expression at 37°C when 18 mM ATP was present. It also showed only a partial response to 2.5 mM Ca<sup>2+</sup>. The parental *Y. pestis* strain showed full growth yield at 37°C and depressed expression of V antigen and of *yop* (yersinial pCD1-encoded outer membrane protein) genes in response to ATP or Ca<sup>2+</sup>. In contrast, the LcrH<sup>-</sup> mutant failed to grow at 37°C in the presence of ATP and showed only limited growth when Ca<sup>2+</sup> was present. V-antigen expression in the mutant was not depressed by ATP and only partially depressed by Ca<sup>2+</sup>. These findings show that LcrH is necessary for the normal response of *Y. pestis* to ATP and that LcrH contributes to Ca<sup>2+</sup> responsiveness. The mutant also showed abnormal *yopJ* expression, indicating that LcrH also is necessary for normal *yop* regulation. The LcrH<sup>-</sup> mutant was avirulent in mice, probably because of its compromised growth at 37°C. These findings indicate that the responses of *Y. pestis* to ATP and Ca<sup>2+</sup> are distinct and that *lcrH* encodes a protein that is an important mediator of Ca<sup>2+</sup> and ATP regulation of pCD1-encoded virulence determinant(s) in *Y. pestis*.

The low-calcium response (Lcr) virulence determinant is encoded by the 75-kilobase (kb) plasmid pCD1 in *Yersinia pestis* KIM (1, 7, 8, 14, 17). The Lcr determinant mediates the requirement of the organism for millimolar concentrations of Ca<sup>2+</sup> for growth at 37°C (7-9, 18, 35), as well as expression of a set of pCD1-encoded virulence-associated proteins, including the V and W antigens (10) and YOPs (yersinial outer membrane proteins) (3, 28, 29).

Cultures of *Y. pestis* shifted from 26 to 37°C in the absence of calcium cease growing within two generations (35), a phenomenon known as growth restriction. Growth can be reinitiated if the cultures are returned to 26°C or if a nucleotide or divalent cation is added to the growth medium (34, 35). During growth restriction, the V and W antigens and YOPs are maximally expressed (9, 10), while net protein synthesis in the cell is shut down (34). A variety of nucleotides, including ATP, can prevent growth restriction in *Y. pestis* KIM (34), as can Ca<sup>2+</sup>, Sr<sup>2+</sup>, and Zn<sup>2+</sup> (35). Mg<sup>2+</sup> exacerbates the Lcr, with the maximal restrictive growth response and V-antigen expression being reached at a concentration of 20 mM Mg<sup>2+</sup> (35). The mechanism by which these molecules regulate the Lcr is unknown. Zahorchak and Brubaker (34) have shown that nucleotides are neither hydrolyzed exogenously nor transported into the bacterium and suggested that they might function by chelating Mg<sup>2+</sup>.

*Y. pestis* mutants have been isolated that show an aberrant response to Ca<sup>2+</sup> (e.g., references 17, 27, 33, and 35). Ca<sup>2+</sup>-blind mutants undergo growth restriction in the presence or absence of Ca<sup>2+</sup> following a temperature shift from 26 to 37°C (33). Ca<sup>2+</sup>-independent mutants do not undergo growth restriction, even in the absence of Ca<sup>2+</sup>, following a temperature shift (27, 35). The term "ATP blind" will be used in this paper to describe a mutant of *Y. pestis* that

undergoes growth restriction in the presence of ATP following a temperature shift from 26 to 37°C.

The genes regulating the Lcr in *Y. pestis* are clustered in an approximately 18-kb region of pCD1, designated *lcrA* through *lcrF* (17, 32, 33). Insertion of Mu dII(Ap<sup>r</sup> *lac*) within this region causes loss of the ability to express high levels of V antigen and YOPs and also results in calcium-independent growth (17). *lcrF* encodes a diffusible component that mediates the enhancement of transcription of some pCD1 genes by temperature (32), while the *lcrE* locus, which lies within the large region originally designated *lcrA*, may be involved in the regulation of pCD1 genes in response to calcium (33).

The *yop* genes are found in at least four distinct loci dispersed around pCD1 (29). *Yop*<sup>-</sup> insertion mutants are normal in their V-antigen expression and calcium dependence for growth at 37°C, suggesting that the *yop* genes are not involved in the regulation of the Lcr (29). V-antigen and *yop* gene expression show similar induction kinetics and similar dependence upon *lcrA* through *lcrF* for induction, reflecting a common regulatory mechanism (26). Interestingly, following induction at 37°C in the absence of Ca<sup>2+</sup> or ATP, the specific activity of the V antigen steadily increases until growth ceases (26, 34). The mechanism underlying this phenomenon is unknown.

Perry et al. (27), using insertion mutagenesis, located the V operon on a 3.6-kb *Hind*III fragment of pCD1 and identified its products and gene order. The V<sup>-</sup> mutant obtained was avirulent, Ca<sup>2+</sup> and ATP independent (i.e., it had lost the Ca<sup>2+</sup>/ATP requirement for growth at 37°C), and did not express the 38-kilodalton (kDa) V antigen or the two other proteins encoded by the operon, the 13-kDa LcrG protein and the 18-kDa LcrH protein. YOP expression was abnormal in this mutant, suggesting that the V operon is involved in regulation of *yop* genes. The investigators designated the V operon *lcrGVH* and concluded that it contained the

\* Corresponding author.

structural gene for the V antigen, at least one virulence gene, and at least one  $\text{Ca}^{2+}$  dependence gene.

We have continued our characterization of the V operon in an effort to define the function of each of the three proteins expressed by it. In the present study, we constructed a mutant of *Y. pestis* unable to express the LcrH protein to determine the role of *lcrH* in  $\text{Ca}^{2+}$ /ATP dependence for growth, V-antigen expression, YOP expression, and virulence. This mutant is the first ATP-blind mutant described, and its phenotype indicates that *lcrH* encodes a regulatory protein that plays a major role in the ATP responsiveness of the yersiniae and a minor role in  $\text{Ca}^{2+}$  responsiveness. LcrH is a regulator of its own *lcrGVH* operon and is required for normal YOP expression. Its inactivation results in avirulence of *Y. pestis*.

### MATERIALS AND METHODS

**Bacteria, bacteriophages, and plasmids.** *Escherichia coli* K-12 strains included HB101 (4),  $\chi$ 2338 (19), and  $\chi$ 1553 (17), all of which were obtained from Roy Curtiss III, Washington University, St. Louis, Mo. These strains and their cultivation have been described previously (17, 27, 29).

*Y. pestis* KIM strains lack the pigmentation virulence determinant (Pgm<sup>-</sup>), rendering them avirulent except by intravenous injection (31). *Y. pestis* KIM6 lacks pCD1, is avirulent, and Lcr<sup>-</sup>. *Y. pestis* KIM5-3173 (pCD1 *yopJ*::Mu d11734) is Lcr<sup>+</sup> but YopJ<sup>-</sup> due to a bacteriophage Mu d11734 insertion in *yopJ* of pCD1. Mu d11734 is a version of Mu d11(Ap<sup>r</sup> *lac*) that lacks the genes necessary for transposition and killing of the host bacterium and contains the neomycin phosphotransferase gene, conferring kanamycin resistance on the host bacterium (11). The original YopJ<sup>-</sup> *Y. pestis* mutant constructed by Straley and Bowmer (29) contained a Mu d11(Ap<sup>r</sup> *lac*) insert in *yopJ*. This insert was replaced with Mu d11734 by homologous recombination following transduction of Mu d11734 from *E. coli* PO11734 (obtained from Malcolm J. Casadaban, University of Chicago, Chicago, Ill.) into *E. coli*  $\chi$ 1553 [pCD1 *yopJ*::Mu d11(Ap<sup>r</sup> *lac*)], with selection for the kanamycin resistance on Mu d11734. Bacteriophage P1L4, which infects and lysogenizes *Y. pestis* but does not produce viable phage in this organism (36), was used to transduce the resulting pCD1 *yopJ*::Mu d11734 from *E. coli*  $\chi$ 1553 into *Y. pestis* KIM6, with selection for kanamycin-resistant, ampicillin-sensitive transductants containing Mu d11734 but not Mu d11(Ap<sup>r</sup> *lac*). The resulting *Y. pestis* KIM5-3173 was confirmed to have the expected *Bam*HI and *Hind*III restriction patterns.

Descriptions of plasmids pBR322, pJIT7, and pCD1 have been reported previously (5, 17, 27). The construction of pJIT7-6 and pCD1 *lcrH*::*cat yopJ*::Mu d11734 are described in this paper.

*Y. pestis* strains were grown as previously described in the defined medium TMH (29).  $\text{MgCl}_2$  (1 or 20 mM) and either 2.5 mM  $\text{CaCl}_2$  or 18 mM disodium ATP were added as noted. All bacteria carrying drug resistance markers were grown in the presence of the appropriate antibiotic(s) at a concentration of 25  $\mu\text{g}/\text{ml}$  (ampicillin and kanamycin) or 5  $\mu\text{g}/\text{ml}$  (chloramphenicol).

**Insertion of the CAT gene into *Hind*III-G.** Plasmid DNA was isolated by the method of Birnboim and Doly (2). Restriction endonuclease digestion and cloning followed standard methods (22). Recombinant clone pJIT7, composed of the V-operon-containing 3.6-kb *Hind*III G fragment of pCD1 inserted into the *Hind*III site of pBR322 (27), was linearized with *Nco*I and filled in with the Klenow fragment

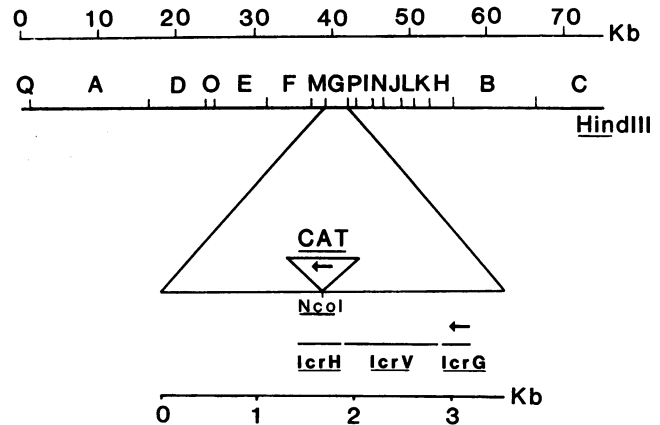

FIG. 1. Construction of pJIT7-6, showing the position of the CAT gene insertion. The *Hind*III restriction map of pCD1 is shown beneath the kilobase scale for the plasmid. The large triangle encompasses the V-operon-containing 3.6-kb *Hind*III G fragment of pCD1. The CAT gene cartridge insertion in the *Hind*III G fragment is indicated by the small triangle which points to the unique *Nco*I site of the fragment. The direction of transcription of the CAT gene and the three genes in the V operon is indicated by the arrows. The locations of the three genes (*lcrG*, *lcrV*, and *lcrH*) in the V operon are diagrammed above the kilobase scale for *Hind*III-G.

of DNA polymerase I (New England BioLabs, Inc., Beverly, Mass.). This was ligated to the similarly blunt-ended 792-base-pair promoterless Tn9 chloramphenicol acetyltransferase (CAT) GenBlock (Pharmacia, Uppsala, Sweden) (Fig. 1). The resulting construct, pJIT7-6, was transformed into *E. coli*  $\chi$ 1553 containing pCD1 *yopJ*::Mu d11734 and also into the *E. coli* minicell-producing strain  $\chi$ 2338.

**Minicell analysis.** Minicells were isolated from *E. coli*  $\chi$ 2338(pJIT7) or  $\chi$ 2338(pJIT7-6), labeled with [<sup>35</sup>S]methionine (0.25 mCi/ml; New England Nuclear Corp., Boston, Mass.), and boiled in electrophoresis sample buffer as described previously (12). Volumes containing 40,000 trichloroacetic acid-precipitable cpm were analyzed on 12% (wt/vol) acrylamide gels by one-dimensional sodium dodecyl sulfate-polyacrylamide gel electrophoresis (SDS-PAGE) (20). The gels were impregnated with En<sup>3</sup>Hance (New England Nuclear), dried, and exposed on X-Omat AR film (Eastman Kodak Co., Rochester, N.Y.) at  $-70^{\circ}\text{C}$  for  $5 \times 10^7$  disintegrations.

**Isolation of *Y. pestis* KIM5-3240 (pCD1 *lcrH*::*cat yopJ*::Mu d11734) by marker exchange mutagenesis.** Cultures of *E. coli*  $\chi$ 1553 transformants containing both pJIT7-6 and pCD1 *yopJ*::Mu d11734 ( $\text{Km}^{\text{r}} \text{Cm}^{\text{r}}$  colonies) were diluted in L broth (23) to 10 CFU/ml and grown for approximately 100 generations to allow for recombination between the native *Hind*III G fragment in pCD1 *yopJ*::Mu d11734 and the CAT-containing *Hind*III G fragment in pJIT7-6. P1L4 lysates were raised on the resulting bacteria and used to transduce *Y. pestis* KIM6. Plasmid DNA from transductants expressing kanamycin and chloramphenicol resistance but lacking ampicillin resistance (indicative of pJIT7-6) was confirmed to have the *Hind*III restriction pattern predicted for pCD1 *lcrH*::*cat yopJ*::Mu d11734. The final LcrH<sup>-</sup> YopJ<sup>-</sup> *Y. pestis* strain thus constructed was designated KIM5-3240.

**Two-dimensional SDS-PAGE analysis.** Both equilibrium and nonequilibrium two-dimensional gels were prepared and compared for *Y. pestis* KIM5-3173 (pCD1 *yopJ*::Mu d11734) and *Y. pestis* KIM5-3240 (pCD1 *lcrH*::*cat yopJ*::Mu d11734). Both yersiniae were grown at  $26^{\circ}\text{C}$  in TMH containing 0.1

mM methionine but no calcium and shifted to 37°C when the culture  $A_{620}$  reached 0.17. Six hours after the temperature shift, when both cultures had entered growth restriction, the cells were labeled with [<sup>35</sup>S]methionine as previously described (27). Samples containing 10<sup>6</sup> cpm were subjected to isoelectric focusing (IEF) (24) or nonequilibrium-pH-gradient electrophoresis (NEPHGE) (25) followed by SDS-PAGE on 12% (wt/vol) acrylamide gels. Fluorography was carried out for approximately 10<sup>9</sup> disintegrations.

**Low-calcium response properties of *Y. pestis* KIM5-3240 (pCD1 *lcrH*::*cat yopJ*::Mu dII734).** Bacterial growth, V-antigen expression, and beta-galactosidase expression were measured as described previously (17, 23, 27, 29). Two concentrations of Mg<sup>2+</sup> were used so that the full ATP effect could be visualized. Protein concentrations were measured by the method of Lowry et al. (21).

**Mouse LD<sub>50</sub> determination.** For mouse 50% lethal dose (LD<sub>50</sub>) determination, exponential-phase cultures of the LcrH<sup>-</sup> YopJ<sup>-</sup> strain of *Y. pestis* KIM5-3240 were grown for 10 generations at 26°C in xylose- and MgCl<sub>2</sub>-supplemented (6) heart infusion broth (Difco Laboratories, Detroit, Mich.) containing kanamycin and chloramphenicol. Cells were sedimented by centrifugation, washed once in phosphate-saline buffer (0.8% NaCl [wt/vol], 8 mM Na<sub>2</sub>PO<sub>4</sub>, 2.7 mM KCl, 1.5 mM KH<sub>2</sub>PO<sub>4</sub> [13]), and resuspended in this buffer as previously described (30). Dilutions of the resuspended bacterial pellets were spread plated in duplicate onto tryptose blood agar base plates with and without kanamycin and chloramphenicol and incubated at 30°C for CFU determinations. Female 6 to 8-week-old BALB/cByJ mice (Jackson Laboratories, Bar Harbor, Maine) were each inoculated retro-orbitally with 0.1-ml volumes of the diluted bacterial suspensions, using five mice per bacterial dose. Each dosage group was caged separately and observed daily for 14 days. An additional mouse was injected with 5.4 × 10<sup>6</sup> CFU and sacrificed 24 h later. A loopful of macerated liver and spleen from this mouse was streaked for isolation onto tryptose blood agar base plates with or without kanamycin and chloramphenicol and incubated at 30°C. Bacteria recovered from the spread plates of the inoculum and from the liver-spleen homogenate were shown to be the challenge strain by demonstrating the appropriate drug resistance, plasmid content, and plasmid restriction enzyme digest pattern.

## RESULTS

The goal of this study was to determine the role of *lcrH* in the Lcr of *Y. pestis*. Our approach was to construct an LcrH<sup>-</sup> mutant and compare its virulence, V-antigen expression, and *yopJ* expression to those of an LcrH<sup>+</sup> strain. The first step was insertion of a CAT cartridge within the *lcrH* gene.

**Minicell analysis.** Before moving the CAT-containing *Hind*III G fragment into pCD1, we checked for its expression of LcrH in *E. coli* minicells. Proteins expressed by pJIT7 and pJIT7-6 in minicells were compared by SDS-PAGE (Fig. 2). As expected, minicells containing pJIT7 clones expressed all three proteins encoded by the V operon, LcrG, LcrV, and LcrH, as well as a fourth protein 42 kDa in size. The genes encoding the 42-kDa protein and a 26-kDa protein not visible in Fig. 2 have been shown previously to be located on a transcriptional unit separate from *lcrGVH* (27).

Clone pJIT7-6 failed to express the 18-kDa LcrH protein, although the LcrG, LcrV, and 42-kDa proteins were expressed, as well as the 24-kDa CAT protein and a 9.5-kDa protein that may have been truncated LcrH (Fig. 2). Expres-

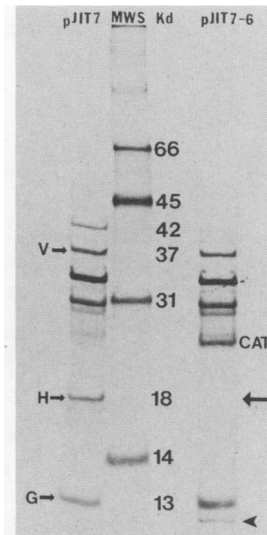

FIG. 2. Expression of the CAT-containing *Hind*III G fragment of pCD1 in *E. coli* minicells. [<sup>35</sup>S]-labeled minicells were prepared from *E. coli* K-12  $\chi$ 2338 containing either the cloned *Hind*III G fragment of pCD1 (pJIT7) or the cloned *Hind*III G fragment containing the CAT insert (pJIT7-6). The center lane contained the molecular size markers (MWS) (sizes indicated in kilodaltons [Kd]). The location of the CAT band expressed by pJIT7-6 is indicated, as are the positions of LcrV (V), LcrH (H), LcrG (G), the missing LcrH band (arrow), and the truncated LcrH protein (arrowhead).

sion of the 42-kDa protein was reduced compared with that in pJIT7-containing minicells. This protein may be YopB; both proteins migrated to similar locations on NEPHGE gels (data not shown). This is consistent with the location of YOP3, the YopB counterpart in *Yersinia pseudotuberculosis* (15). The meaning of this reduced expression of the 42-kDa protein is unknown. However, we show in this work that *lcrH* does function in regulation of the distant *yopJ* gene. Accordingly, it is possible that *lcrH* can affect the expression of the 42-kDa protein in *E. coli*. Previous data from our laboratory have shown that the 42-kDa protein is expressed in an LcrGVH<sup>-</sup> mutant (27), so it seems unlikely that *yopB* lies within *lcrGVH*.

No LcrH-CAT fusion protein was expressed by pJIT7-6. Sequence analysis of *lcrH* has revealed that the promoterless CAT cartridge should have been inserted in a different reading frame from that of *lcrH* (S. B. Price, K. Y. Leung, S. S. Barve, and S. C. Straley, submitted for publication). Further, two translational stop codons, located within the CAT gene sequence but upstream from the CAT initiation codon, were present in the *lcrH* reading frame. These stop codons, coupled with two potential ribosome-binding sites present within this upstream sequence which could allow for reinitiation of translation, probably resulted in the expression of normal-size CAT protein. The portion of the *lcrH* sequence upstream from the *Nco*I insertion site for the CAT gene could encode a 9.5-kDa truncated LcrH protein (Price et al., submitted). This amino-terminal portion of the LcrH protein may be the extra protein expressed by pJIT7-6-containing minicells, visible beneath the LcrG band in Fig. 2.

**Two-dimensional electrophoretic analysis of LcrH<sup>-</sup> YopJ<sup>-</sup> *Y. pestis* (pCD1 *lcrH*::*cat yopJ*::Mu dII734).** To determine whether the LcrH<sup>-</sup> phenotype had been successfully transferred into the yersinial background, two-dimensional IEF and NEPHGE analyses were performed with [<sup>35</sup>S]methio-

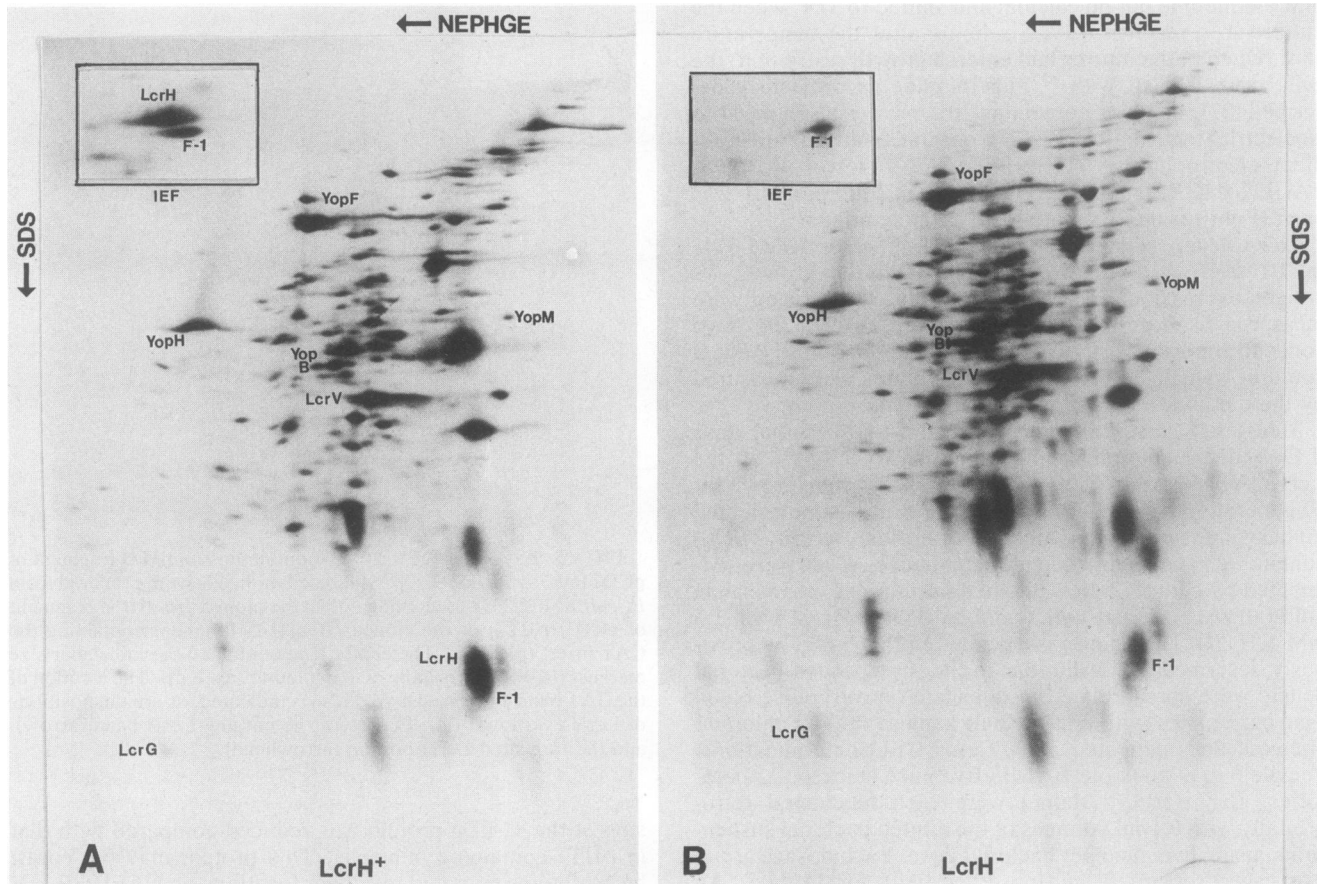

FIG. 3. Two-dimensional protein profiles of  $LcrH^+$   $YopJ^-$  and  $LcrH^-$   $YopJ^-$  *Y. pestis* KIM. *Y. pestis* KIM5-3173 (pCD1 *yopJ*::Mu dI1734) and KIM5-3240 (pCD1 *lcrH*::*cat yopJ*::Mu dI1734) were grown and labeled with [ $^{35}$ S]methionine. The first-dimension electrophoresis was either NEPHGE (main panels) or IEF (insets). The second dimensions were electrophoresed into 12% acrylamide gels. The locations of the proteins encoded by *lcrGVH*, as well as several of the YOP proteins and the fraction 1 capsular protein (F-1), are indicated.

nine-labeled cells from *Y. pestis* KIM5-3173, which is  $LcrH^+$   $YopJ^-$ , and with similarly labeled cells from *Y. pestis* KIM5-3240, the  $LcrH^-$   $YopJ^-$  transductant that carries the CAT gene inserted into its *Hind*III G fragment in pCD1. In NEPHGE gels, the 18-kDa LcrH protein migrated very near a chromosomally encoded virulence protein of *Y. pestis*, the fraction 1 capsular antigen (Fig. 3A). However, IEF of the same sample separated the two proteins (Fig. 3A, inset). Comigration of [ $^{35}$ S]-labeled proteins from pJIT7-containing *E. coli* minicells, which express *lcrGVH*, with labeled supernatant proteins from *Y. pestis* KIM5-3142 [pCD1 *lcrG*::Mu dI1(Ap<sup>r</sup> *lac*)], which is  $LcrGVH^-$  (27), demonstrated that the LcrH protein migrated above the fraction 1 capsular antigen in two-dimensional IEF gels (unpublished data). Western blot (immunoblot) analysis using anti-fraction 1 serum confirmed the orientation of the two proteins (unpublished data). Knowledge of the position of LcrH in IEF gels helped confirm that *Y. pestis* (pCD1 *lcrH*::*cat yopJ*::Mu dI1734) did not express LcrH (Fig. 3B).

The  $LcrH^-$   $YopJ^-$  mutant did express other pCD1-encoded proteins, however, including the other two proteins encoded by the V operon, LcrG and LcrV, and YOPs other than YopJ (Fig. 3B). The 42-kDa YopB protein was also expressed in apparently normal amounts by this *Y. pestis* mutant, in contrast to its reduced expression observed in *E. coli* minicells (Fig. 2). YopF, YopH, and YopM also ap-

peared to be expressed in normal amounts by the  $LcrH^-$   $YopJ^-$  mutant.

CAT appeared to be only weakly expressed in this mutant, and the protein spot corresponding to it is not easily visible in Fig. 3. The weak expression of CAT may explain why *Y. pestis* KIM5-3240 grew poorly in media containing chloramphenicol concentrations greater than 5  $\mu$ g/ml (data not shown).

Other differences in the protein profiles of the  $LcrH^+$   $YopJ^-$  and  $LcrH^-$   $YopJ^-$  mutants are visible on these gels. However, we do not yet know their significance.

**Response of the mutant to calcium and ATP.** The  $LcrH^-$   $YopJ^-$  mutant *Y. pestis* KIM5-3240 grew similarly to the  $LcrH^+$   $YopJ^-$  parent strain at 26°C and showed normal growth restriction in the absence of  $Ca^{2+}$  following a temperature shift to 37°C (Fig. 4). However, growth restriction of the  $LcrH^-$  mutant following the temperature shift was not relieved at all in the presence of 18 mM ATP and was only partially relieved in the presence of 2.5 mM  $Ca^{2+}$  (Fig. 4B). The parental  $LcrH^+$   $YopJ^-$  strain responded normally to both  $Ca^{2+}$  and ATP (Fig. 4A). These findings show that the  $LcrH^-$  mutant is ATP-blind and aberrant in its response to  $Ca^{2+}$ .

Likewise, the  $LcrH^-$  mutant was aberrant in its  $Ca^{2+}$  and ATP regulation of V-antigen expression. The  $LcrH^-$  mutant expressed the same amount of V antigen at 37°C as did the

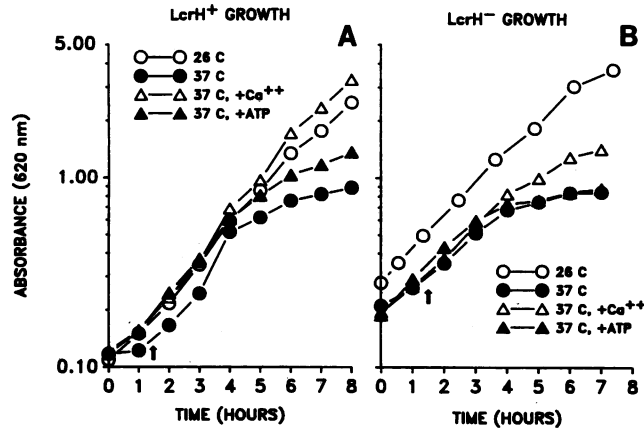

FIG. 4. Growth of *Y. pestis* KIM5-3173 LcrH<sup>+</sup> YopJ<sup>-</sup> (A) and *Y. pestis* KIM5-3240 LcrH<sup>-</sup> YopJ<sup>-</sup> (B) in TMH containing 20 mM Mg<sup>2+</sup>. Bacteria were grown at 26°C in TMH containing 2.5 mM Ca<sup>2+</sup>, 18 mM ATP, or no addition, and the temperature was shifted to 37°C following one generation of growth (arrow). A control culture was maintained at 26°C.

LcrH<sup>+</sup> strain when the medium was not supplemented with either Ca<sup>2+</sup> or ATP (Fig. 5). However, in contrast to the parent strain, the mutant expressed high levels of V antigen in the presence of Ca<sup>2+</sup> or ATP, with greater expression occurring in the presence of ATP. This pattern correlates inversely with the growth yields of the mutant under these conditions (Fig. 4B) and follows the well-established but poorly understood relation of V expression with growth (9, 35). Apparently all of the components necessary for V expression are present in the LcrH<sup>-</sup> mutant, and loss of LcrH removed the negative effects of Ca<sup>2+</sup> and ATP on expression of LcrV.

The pattern of *yopJ* transcription (reflected by beta-galactosidase activity) by the LcrH<sup>-</sup> mutant was different from

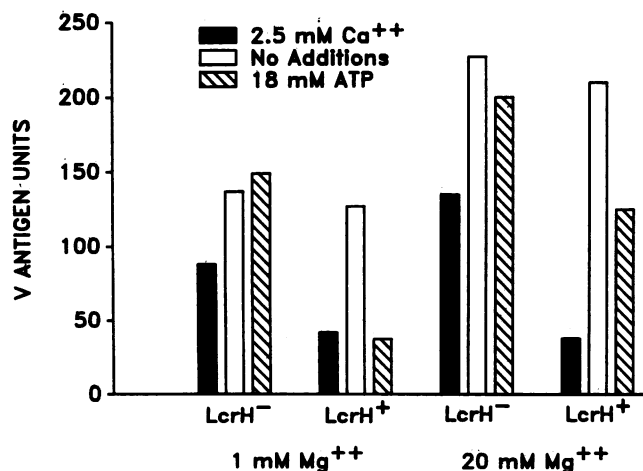

FIG. 5. V-antigen expression by *Y. pestis* KIM5-3173 LcrH<sup>+</sup> YopJ<sup>-</sup> and *Y. pestis* KIM5-3240 LcrH<sup>-</sup> YopJ<sup>-</sup> grown in TMH containing 1 or 20 mM Mg<sup>2+</sup>. Bacteria were grown at 26°C in TMH containing 2.5 mM Ca<sup>2+</sup>, 18 mM ATP, or no addition and shifted to 37°C following one generation of growth. Samples for assay of V-antigen activity were taken 6 h after the temperature shift. One unit of V-antigen activity is defined as 1 cm of rocket height per mg of protein electrophoresed (rocket immunoelectrophoresis).

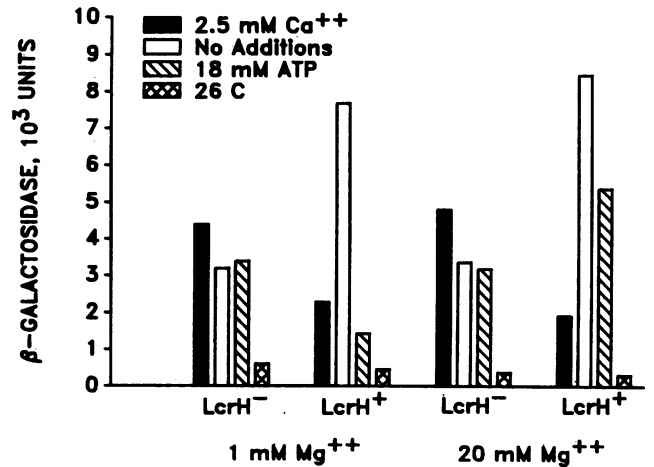

FIG. 6. Beta-galactosidase expression by *Y. pestis* KIM5-3173 (pCD1 *yopJ*::Mu dl1734 LcrH<sup>+</sup>) and *Y. pestis* KIM5-3240 (pCD1 *lcrH*::*cat yopJ*::Mu dl1734 LcrH<sup>-</sup>) grown in TMH containing 1 or 20 mM Mg<sup>2+</sup>. Bacteria were grown at 26°C in TMH containing 2.5 mM Ca<sup>2+</sup>, 18 mM ATP, or no addition and shifted to 37°C following one generation of growth. A control culture was maintained at 26°C. Samples for assay of beta-galactosidase activity were taken 6 h after the temperature shift. One unit of beta-galactosidase activity is defined as 1 nM of *o*-nitrophenyl-β-D-galactopyranoside hydrolyzed per min per mg of protein.

that for the V antigen (Fig. 6). The mutant expressed this gene at normal basal levels at 26°C, but at 37°C in unsupplemented medium it failed to show the strong induction of *yopJ* characteristic of the parental strain. Inclusion of Ca<sup>2+</sup> or ATP in the medium had little effect on *yopJ* transcription because the mutant is partially or completely blind to these compounds, respectively. One or more elements necessary for normal *yopJ* transcription are missing in the LcrH<sup>-</sup> mutant, suggesting a role for LcrH as a modulator of YopJ expression. This finding is significant because it suggests differential regulation of at least one YOP and the V antigen.

Measurements of V antigen and *yopJ* expression were done in the presence of 1 or 20 mM Mg<sup>2+</sup> to demonstrate the effect of the Mg<sup>2+</sup> concentration on *lcr* gene expression (Fig. 5 and 6). In low concentrations of Mg<sup>2+</sup>, 18 mM ATP relieved growth restriction in the LcrH<sup>+</sup> YopJ<sup>-</sup> parent strain (data not shown), resulting in reduced expression of YOPs and V antigen. This effect was similar to that of Ca<sup>2+</sup>; however, it may have arisen, at least in part, from the removal of Mg<sup>2+</sup> by chelation to ATP. The higher concentration of Mg<sup>2+</sup> diminished the effect of ATP, perhaps because the ATP was ineffective at chelating the larger amount of Mg<sup>2+</sup> (34). Consequently, growth restriction was only partially relieved (Fig. 4), and the V antigen and *yopJ* were expressed in higher amounts. Because the LcrH<sup>-</sup> mutant apparently does not "sense" ATP, expression of *yopJ* by this mutant in the presence of ATP was similar in both concentrations of Mg<sup>2+</sup>. This was true also for V expression, if expression in the presence of ATP relative to that for no additions is compared for the two Mg<sup>2+</sup> concentrations.

**Virulence testing.** The LcrH<sup>-</sup> YopJ<sup>-</sup> mutant was avirulent, with an LD<sub>50</sub> > 5 × 10<sup>6</sup> CFU. In contrast, LcrH<sup>+</sup> YopJ<sup>-</sup> *Y. pestis* KIM5-3073, which has a Mu dl1(Ap<sup>r</sup> *lac*):Tn9 insertion at the same site (*yopJ*) as Mu dl1734 in the *lcrH* mutant constructed here, was reported previously to have an LD<sub>50</sub> of 1.2 × 10<sup>2</sup> CFU (29). Mice that received

the highest dose of the LcrH<sup>-</sup> mutant developed moderate conjunctivitis in the injected eye but otherwise appeared normal throughout the 2-week observation period, as did all mice receiving lower doses. These findings suggest that *lcrH* encodes a protein that regulates the response of *Y. pestis* to ATP and Ca<sup>2+</sup>, two environmental stimuli which are closely linked to virulence. Loss of LcrH may result in avirulence of the organism due to its inability to multiply at mouse body temperature (37°C) whether or not Ca<sup>2+</sup> or nucleotides are present, leading to its rapid clearance by the host immune system. However, our data do not prove that uncontrolled growth restriction is the cause of the avirulence of the LcrH<sup>-</sup> mutant. Further, growth restriction has not been shown conclusively to occur in vivo.

### DISCUSSION

The purpose of this study was to determine the function of *lcrH* in the V operon of *Y. pestis*. The data presented in this paper suggest a regulatory role for *lcrH* in the response of the organism to Ca<sup>2+</sup> and ATP. The LcrH<sup>-</sup> mutant of *Y. pestis* constructed in this study was aberrant in its response to Ca<sup>2+</sup>, showing only slight relief of growth restriction in its presence, and was also ATP-blind, showing no relief of growth restriction in the presence of 18 mM ATP (Fig. 4B). This is the first ATP-blind mutant of *Y. pestis* described, and it will facilitate future investigations of the mechanism by which ATP (or other nucleotides) relieve growth restriction (34), a phenomenon which is presently not well understood. For example, we do not know whether ATP itself is sensed by the yersiniae or whether ATP has its effect by lowering the free Mg<sup>2+</sup> concentration (34). We use phrases such as ATP blind and responsive to ATP only empirically and not to indicate molecular mechanisms. However, our data showing different extents of loss of Ca<sup>2+</sup> and ATP responsiveness in the LcrH<sup>-</sup> mutant do reveal that the Ca<sup>2+</sup>- and ATP-sensory/response pathways in the Lcr are not identical.

Unlike the LcrGVH<sup>-</sup> mutant, the LcrH<sup>-</sup> mutant expressed normal amounts of the V antigen in the absence of added Ca<sup>2+</sup> or ATP (Fig. 5). However, due to its inability to respond fully to Ca<sup>2+</sup> or at all to ATP, the LcrH<sup>-</sup> mutant expressed the V antigen essentially constitutively at 37°C. Yet despite its strong expression of the V antigen, which is considered to be a major virulence determinant of *Y. pestis* (8), the LcrH<sup>-</sup> mutant was avirulent in mice.

In contrast to the V antigen and YOPs, LcrH is not released into the growth medium, and unlike the YOPs, it is not labeled by <sup>125</sup>I at the bacterial surface (unpublished data and S. C. Straley and M. L. Cibull, submitted for publication). We have no evidence that the LcrH protein is directly antihost, and therefore it cannot be considered an invasive virulence determinant of *Y. pestis*. The results of this study suggest, instead, that *lcrH* encodes a protein that regulates the growth of the pathogen and its expression of virulence genes in response to Ca<sup>2+</sup> and ATP and that this normal regulation is essential for virulence.

The LcrH<sup>-</sup> phenotype is different from the LcrGVH<sup>-</sup> phenotype described previously (27). The *lcrGVH* mutant is Ca<sup>2+</sup> and ATP independent; i.e., it does not require Ca<sup>2+</sup> or ATP for growth at 37°C. This insertion mutant did not express LcrG, LcrV, or LcrH and did not undergo growth restriction at 37°C in the absence of Ca<sup>2+</sup> and ATP. The *lcrH* mutant, in contrast, is ATP blind and partially Ca<sup>2+</sup> blind. This mutant expressed LcrG and LcrV, but not LcrH, did undergo growth restriction at 37°C in the presence or absence of ATP, and showed reduced growth in the presence

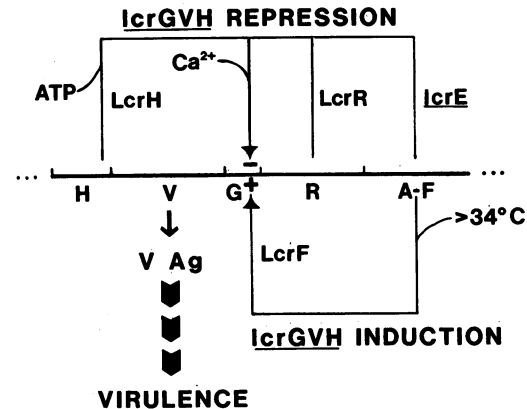

FIG. 7. Proposed model for regulation of *lcrGVH*.

of Ca<sup>2+</sup>. These findings taken together indicate that growth restriction is not caused by LcrH. This phenomenon must be caused by LcrG, LcrV, or a combination of the two.

Yother and Goguen (33) described Ca<sup>2+</sup>-blind mutants of *Y. pestis*, obtained by ethyl methanesulfonate mutagenesis, that also produced the V antigen constitutively. These mutations defined the *lcrE* locus at ca. 48 kb on the pCD1 map, within the calcium dependence locus originally designated *lcrA* (17). This finding indicates that at least one gene within the calcium dependence region may be directly involved in the *Y. pestis* response to Ca<sup>2+</sup>. The *lcrE* mutants responded normally to ATP (J. Yother, personal communication), unlike the *lcrH* mutant characterized in this study. Using Tn5 insertional mutagenesis, Yother et al. (32) studied a temperature-controlled locus, *trtB*. The *trtB* mutants were unable to express the V antigen and unable to grow at 37°C in the presence of Ca<sup>2+</sup> and thus were distinct from the *lcrH* mutant described here. We do not yet know how the *lcrE* and *trtB* loci relate to the *lcrH* locus. The ATP responsiveness of the *trtB* mutants was not reported, and nothing is known about the expression of LcrH or YOPs by either the *lcrE* or *trtB* mutants.

Recently, Forsberg and Wolf-Watz (16) have described a mutant of *Y. pseudotuberculosis* that has a drug resistance gene inserted into the V gene. This mutant expresses the *yopE* gene constitutively at 37°C regardless of the concentration of Ca<sup>2+</sup> present, suggesting that *lcrV* is a negative regulator of YOP expression (Fig. 7). The investigators did not determine whether the LcrG, LcrV, and LcrH proteins are expressed by their mutant and did not analyze the response of the mutant to ATP. If the insertion had a polar effect on expression of *lcrH*, then this double mutant could also be ATP blind. It is apparent, though, that not all YOPs are regulated similarly, since this mutation in *lcrV* resulted in increased *yopE* expression while the mutation in *lcrH* described in this paper resulted in decreased expression of *yopJ*.

The simplest model of the role of the LcrH protein in regulating *lcrGVH*, and one that would account for most of the data presented here, would be to assign LcrH a function in mediating responsiveness of *Y. pestis* to ATP and Ca<sup>2+</sup> (Fig. 7). A Ca<sup>2+</sup>-sensing function has previously been hypothesized to be encoded by the V operon (27). In this model, the LcrH protein in the presence of ATP or Ca<sup>2+</sup> would repress *lcrGVH* at 37°C. In the absence of Ca<sup>2+</sup> or ATP, or of LcrH, the operon is strongly expressed. The calcium dependence genes *lcrA(D,E)*, *lcrB*, *lcrC*, and *lcrF* are necessary for this induction of *lcrGVH*. However, this

model does not account for the partial relief of growth restriction (Fig. 4B) and the concomitantly reduced expression of LcrV (Fig. 5) observed when the LcrH<sup>-</sup> mutant was grown at 37°C in the presence of Ca<sup>2+</sup>. The LcrH<sup>-</sup> mutant is thus partially Ca<sup>2+</sup> responsive, requiring the function of an additional component(s) for a full response.

One such component may be encoded by *lcrE*; another may be the product of the adjacent *lcrR* gene, because yersiniae defective in *lcrR* also are Ca<sup>2+</sup> blind (S. S. Barve and S. C. Straley, manuscript in preparation) (Fig. 7). The partial relief of growth restriction by Ca<sup>2+</sup> in the LcrH<sup>-</sup> mutant and the concomitantly reduced expression of the V antigen may result from basal expression or function of LcrR or of the product of *lcrE* at 37°C in the absence of the LcrH protein. The result would be the partial, Ca<sup>2+</sup>-mediated depression of V-antigen expression from *lcrGVH*.

The LcrH protein may also be necessary for the normal expression of *yopJ*. The measurements of beta-galactosidase activity indicated lower *yopJ* expression by the LcrH<sup>-</sup> mutant than by the parent at 37°C in the absence of Ca<sup>2+</sup> or ATP (Fig. 6). We do not know why the LcrH protein is needed for normal *yopJ* expression; it probably is only one of multiple regulators, because the reduced YopJ expression by the LcrH<sup>-</sup> mutant was still much greater than the basal level expression at 26°C (Fig. 6). This residual *yopJ* induction may be due at least in part to *trans*-activation by the *lcrF* gene product, thought to mediate the thermally enhanced expression of some Lcr genes (32). Also, it is apparent that not all YOPs are affected by the loss of LcrH, since YopF, YopH, and YopM were expressed in normal amounts in the LcrH<sup>-</sup> YopJ<sup>-</sup> mutant (Fig. 3). This differential expression of YOPs is significant new information about their regulation.

The dual regulatory function of *lcrH*, as a repressor of *lcrGVH* and as an effector of *yopJ* expression, suggests that *lcrH*, located at 40 kb on the pCD1 map, is an important coordinate regulator of pCD1-encoded virulence determinants in *Y. pestis*. Our data reveal the major role LcrH has in mediating Ca<sup>2+</sup> and ATP responsiveness in this pathogen. The avirulence of the LcrH<sup>-</sup> mutant defective in regulation of V-antigen and YopJ expression underscores the importance to pathogenesis of regulation of virulence genes and growth by environmental inputs. Moreover, this work revealed that Ca<sup>2+</sup> and ATP (or Mg<sup>2+</sup>) are distinct environmental signals for *Y. pestis*.

#### ACKNOWLEDGMENTS

We thank Clarissa Cowan and Ruth Ann Bivins for skillful technical assistance and Carol Pickett and Edward DeMoll for critical reading of the manuscript.

This work was supported by Public Health Service grant AI 21017 from the National Institute of Allergy and Infectious Diseases and by National Science Foundation Grant DCB-8409128.

#### LITERATURE CITED

- Ben-Gurion, R., and A. Shafferman. 1981. Essential virulence determinants of different *Yersinia* species are carried on a common plasmid. *Plasmid* 5:183-187.
- Birnboim, H. C., and J. Doly. 1979. A rapid alkaline extraction procedure for screening recombinant plasmid DNA. *Nucleic Acids Res.* 7:1513-1523.
- Bolin, I., D. A. Portnoy, and H. Wolf-Watz. 1985. Expression of the temperature-inducible outer membrane proteins of yersiniae. *Infect. Immun.* 48:234-240.
- Bolivar, F., and K. Backman. 1979. Plasmids of *Escherichia coli* as cloning vectors. *Methods Enzymol.* 68:245-267.
- Bolivar, F., R. L. Rodriguez, P. J. Greene, M. C. Betlach, H. L. Heynecker, H. W. Boyer, J. H. Crosa, and S. Falkow. 1977. Construction and characterization of new cloning vehicles. II. A multipurpose cloning system. *Gene* 2:95-113.
- Brubaker, R. R. 1969. Mutation rate to nonpigmentation in *Pasteurella pestis*. *J. Bacteriol.* 98:1404-1406.
- Brubaker, R. R. 1972. The genus *Yersinia*: biochemistry and genetics of virulence. *Curr. Top. Microbiol. Immunol.* 57:111-158.
- Brubaker, R. R. 1979. Expression of virulence in yersiniae, p. 168-171. In D. Schlessinger (ed.), *Microbiology—1979*. American Society for Microbiology, Washington, D.C.
- Brubaker, R. R., and M. J. Surgalla. 1964. The effect of Ca<sup>++</sup> and Mg<sup>++</sup> on lysis, growth, and production of virulence antigens by *Pasteurella pestis*. *J. Infect. Dis.* 114:13-25.
- Burrows, T. W., and G. A. Bacon. 1956. The basis of virulence in *Pasteurella pestis*: an antigen determining virulence. *Br. J. Exp. Pathol.* 37:481-493.
- Castilho, B. A., P. Olfson, and M. Casadaban. 1984. Plasmid insertion mutagenesis and *lac* gene fusion with mini-Mu bacteriophage transposons. *J. Bacteriol.* 158:488-495.
- Clark-Curtiss, J. E., and R. Curtiss III. 1983. Analysis of recombinant DNA using *Escherichia coli* minicells. *Methods Enzymol.* 101:347-362.
- Dulbecco, R., and M. Vogt. 1954. Plaque formation and isolation of pure lines with poliomyelitis viruses. *J. Exp. Med.* 99:167-182.
- Ferber, D. M., and R. R. Brubaker. 1981. Plasmids in *Yersinia pestis*. *Infect. Immun.* 27:839-841.
- Forsberg, A., I. Bolin, L. Norlander, and H. Wolf-Watz. 1987. Molecular cloning and expression of calcium-regulated, plasmid-coded proteins of *Y. pseudotuberculosis*. *Microb. Pathog.* 2:123-137.
- Forsberg, A., and H. Wolf-Watz. 1988. The virulence protein Yop5 of *Yersinia pseudotuberculosis* is regulated at transcriptional level by plasmid-pIB1-encoded *trans*-acting elements controlled by temperature and calcium. *Mol. Microbiol.* 2:121-133.
- Goguen, J. D., J. Yother, and S. C. Straley. 1984. Genetic analysis of the low calcium response in *Yersinia pestis* Mu d1(Ap *lac*) insertion mutants. *J. Bacteriol.* 160:842-848.
- Higuchi, K., L. L. Kupferberg, and J. L. Smith. 1959. Studies on the nutrition and physiology of *Pasteurella pestis*. III. Effects of calcium ions on the growth of virulent and avirulent strains of *Pasteurella pestis*. *J. Bacteriol.* 77:317-321.
- Jacobs, W. R., J. F. Barrett, J. E. Clark-Curtiss, and R. Curtiss III. 1986. In vivo repackaging of recombinant cosmid molecules for analyses of *Salmonella typhimurium*, *Streptococcus mutants*, and mycobacterial genomic libraries. *Infect. Immun.* 52:101-109.
- Laemmli, U. K. 1970. Cleavage of structural proteins during the assembly of the head of bacteriophage T4. *Nature (London)* 227:680-685.
- Lowry, O. H., N. J. Rosebrough, A. L. Farr, and R. J. Randall. 1951. Protein measurement with the Folin phenol reagent. *J. Biol. Chem.* 193:265-275.
- Maniatis, T., E. F. Fritsch, and J. Sambrook. 1982. *Molecular cloning: a laboratory manual*. Cold Spring Harbor Laboratory, Cold Spring Harbor, N.Y.
- Miller, J. H. 1977. *Experiments in molecular genetics*, p. 352-355. Cold Spring Harbor Laboratory, Cold Spring Harbor, N.Y.
- O'Farrell, P. H. 1975. High resolution two-dimensional electrophoresis of proteins. *J. Biol. Chem.* 250:4007-4021.
- O'Farrell, P. Z., H. M. Goodman, and P. H. O'Farrell. 1977. High resolution two-dimensional electrophoresis of basic as well as acidic proteins. *Cell* 12:1133-1142.
- Perry, R. D., P. Haddix, E. B. Atkins, T. K. Soughers, and S. C. Straley. 1987. Regulation of expression of V antigen and outer membrane proteins in *Yersinia pestis*. *Contrib. Microbiol. Immunol.* 9:173-178.
- Perry, R. D., P. A. Harmon, W. S. Bowmer, and S. C. Straley. 1986. A low-Ca<sup>2+</sup> response operon encodes the V antigen of *Yersinia pestis*. *Infect. Immun.* 54:428-434.
- Portnoy, D. A., H. Wolf-Watz, I. Bolin, A. B. Beeder, and S.

- Falkow. 1984. Characterization of common virulence plasmids in *Yersinia* species and their role in the expression of outer membrane proteins. *Infect. Immun.* **43**:108-114.
29. Straley, S. C., and W. S. Bowmer. 1986. Virulence genes regulated at the transcriptional level by  $\text{Ca}^{2+}$  in *Yersinia pestis* include structural genes for outer membrane proteins. *Infect. Immun.* **51**:445-454.
30. Straley, S. C., and P. A. Harmon. 1984. Growth in mouse peritoneal macrophages of *Yersinia pestis* lacking established virulence determinants. *Infect. Immun.* **45**:649-654.
31. Une, T., and R. R. Brubaker. 1984. In vivo comparison of avirulent  $\text{Vwa}^-$  and  $\text{Pgm}^-$  or  $\text{Pst}^+$  phenotypes of yersiniae. *Infect. Immun.* **43**:895-900.
32. Yother, J., T. W. Chamness, and J. D. Goguen. 1986. Temperature-controlled plasmid regulon associated with low calcium response in *Yersinia pestis*. *J. Bacteriol.* **165**:443-447.
33. Yother, J., and J. D. Goguen. 1985. Isolation and characterization of  $\text{Ca}^{2+}$ -blind mutants of *Yersinia pestis*. *J. Bacteriol.* **164**:704-711.
34. Zahorchak, R. J., and R. R. Brubaker. 1982. Effect of exogenous nucleotides on  $\text{Ca}^{2+}$  dependence and V antigen synthesis in *Yersinia pestis*. *Infect. Immun.* **38**:953-959.
35. Zahorchak, R. J., W. T. Charnetzky, R. V. Little, and R. R. Brubaker. 1979. Consequences of  $\text{Ca}^{2+}$  deficiency on macromolecular synthesis and adenylate energy charge in *Yersinia pestis*. *J. Bacteriol.* **139**:792-799.
36. Zitman, D., and R. Ben-Gurion. 1972. Transduction of *Pasteurella pestis*. *Virology* **47**:513-516.