

# Recombination in IS26 and Tn2 in the Evolution of Multiresistance Regions Carrying *bla*<sub>CTX-M-15</sub> on Conjugative IncF Plasmids from *Escherichia coli*<sup>†</sup>

Sally R. Partridge,<sup>1\*</sup> Zhiyong Zong,<sup>1,2</sup> and Jonathan R. Iredell<sup>1</sup>

Centre for Infectious Diseases and Microbiology, University of Sydney, Westmead Hospital, Sydney, New South Wales 2145, Australia,<sup>1</sup> and Department of Infectious Diseases, West China Hospital, Sichuan University, Chengdu, China<sup>2</sup>

Received 7 January 2011/Returned for modification 1 April 2011/Accepted 12 August 2011

**CTX-M-15 now appears to be the dominant extended-spectrum  $\beta$ -lactamase worldwide, and a number of different factors may contribute to this success. These include associations between *bla*<sub>CTX-M-15</sub> and particular plasmids (IncF) and/or strains, such as *Escherichia coli* ST131, as well as the genetic contexts in which this gene is found. We previously identified *bla*<sub>CTX-M-15</sub> as the dominant ESBL gene in the western Sydney area, Australia, and found that it was carried mainly on IncF or IncII plasmids. Here, we have mapped the multiresistance regions of the 11 conjugative plasmids with one or more IncF replicons obtained from that survey and conducted a limited comparison of plasmid backbones. Two plasmids with only an IncFII replicon appear to be very similar to the published plasmids pC15-1a and pEK516. The remaining nine plasmids, with multiple IncF replicons, have multiresistance regions related to those of pC15-1a and pEK516, but eight contain additional modules previously found in resistance plasmids from different geographic locations that carry a variety of different resistance genes. Differences between the multiresistance regions are largely due to IS26-mediated deletions, insertions, and/or rearrangements, which can explain the observed variable associations between *bla*<sub>CTX-M-15</sub> and certain other resistance genes. We found no evidence of independent movement of *bla*<sub>CTX-M-15</sub> or of a large multiresistance region between different plasmid backbones. Instead, homologous recombination between common components, such as IS26 and Tn2, appeared to be more important in creating new multiresistance regions, and this may be coupled with recombination in plasmid backbones to reassort multiple IncF replicons as well as components of multiresistance regions.**

The CTX-M family of extended-spectrum  $\beta$ -lactamases (ESBLs) has recently become the dominant ESBL type in *Enterobacteriaceae* worldwide (5, 7). Among these, CTX-M-15, belonging to the CTX-M-1 group, appears to be the most widespread, particularly in *Escherichia coli*, and is associated with both hospital and community-acquired infections. The successful spread of a particular antibiotic resistance gene like *bla*<sub>CTX-M-15</sub> may be influenced by a number of factors, including the mobile genetic element responsible for its capture/mobilization, the plasmids on which it is found, and clonal spread of strains. The international spread of *bla*<sub>CTX-M-15</sub> is known to be partially linked to the *E. coli* O25 sequence type 131 (ST131) clonal group (10, 24, 32, 35), but *bla*<sub>CTX-M-15</sub> is also found in other clonal groups, e.g., ST405 (10).

*bla*<sub>CTX-M-15</sub> has always been found in association with the insertion sequence (IS) *ISEcp1*, which captures adjacent genes by using its left-hand inverted repeat (IR<sub>L</sub>) in conjunction with loosely related sequences downstream of each gene and also provides a promoter (19, 33, 34). Where enough flanking sequence is available, *bla*<sub>CTX-M-15</sub> is generally found 48 bp beyond the right-hand inverted repeat (IR<sub>R</sub>) of *ISEcp1* as part of a 2,971-bp transposition unit that also includes a partial open

reading frame (*orf477* $\Delta$ ) (6, 11, 13, 44). While an association with *ISEcp1* may contribute to the success of *bla*<sub>CTX-M-15</sub>, many other genes associated with *ISEcp1* are apparently much less widespread, suggesting that other factors are also important.

Surveys in several different countries (4, 10, 17, 20, 26, 50) have indicated that *bla*<sub>CTX-M-15</sub> is often carried by IncF plasmids, many of which have multiple replicons and multiple antibiotic resistance genes. Unlike plasmids belonging to some other Inc groups, the backbones of IncF plasmids appear to be quite diverse, in terms of size, number of replicons present, and conjugation ability, due to extensive recombination events (28). The first IncF plasmid carrying *bla*<sub>CTX-M-15</sub> to be completely sequenced was pC15-1a (GenBank accession no. AY458016), isolated in Canada (6). In pC15-1a, the *ISEcp1*–*bla*<sub>CTX-M-15</sub>–*orf477* $\Delta$  transposition unit is inserted in Tn2 (1), flanked by 5-bp direct repeats (DRs). Tn2 carries a *tnpA* (transposase) gene separated by a resolution (*res*) site from a *tnpR* (resolvase) gene and *bla*<sub>TEM-1b</sub> and is bounded by 38-bp inverted repeats (designated IR<sub>mp</sub> and IR<sub>TEM</sub> here). In pC15-1a, the IR<sub>mp</sub> end of Tn2 is truncated by IS26 and the Tn2–*ISEcp1*–*bla*<sub>CTX-M-15</sub>–*orf477* $\Delta$ –Tn2 $\Delta$  structure is part of a larger (28.5 kb) multiresistance region (MRR) that also includes the *aac*(6′)-*Ib*-*cr*, *aac*(3)-*Ile* (29), *bla*<sub>OXA-30</sub>, and *tetA*(A) antibiotic resistance genes and several copies of IS26 (Fig. 1A).

A few additional IncF plasmids from *E. coli* carrying *bla*<sub>CTX-M-15</sub> have now also been completely sequenced. The IncFII plasmid pEK516 (GenBank accession no. EU935738) from an ST131 isolate of United Kingdom strain D (44) is

\* Corresponding author. Mailing address: CIDM, Level 3, ICPMR Building, Westmead Hospital, Sydney, NSW 2145, Australia. Phone: (61-2) 9845 5246. Fax: (61-2) 9891 5317. E-mail: sally.partridge@swahs.health.nsw.gov.au.

† Supplemental material for this article may be found at <http://aac.asm.org/>.

<sup>‡</sup> Published ahead of print on 22 August 2011.

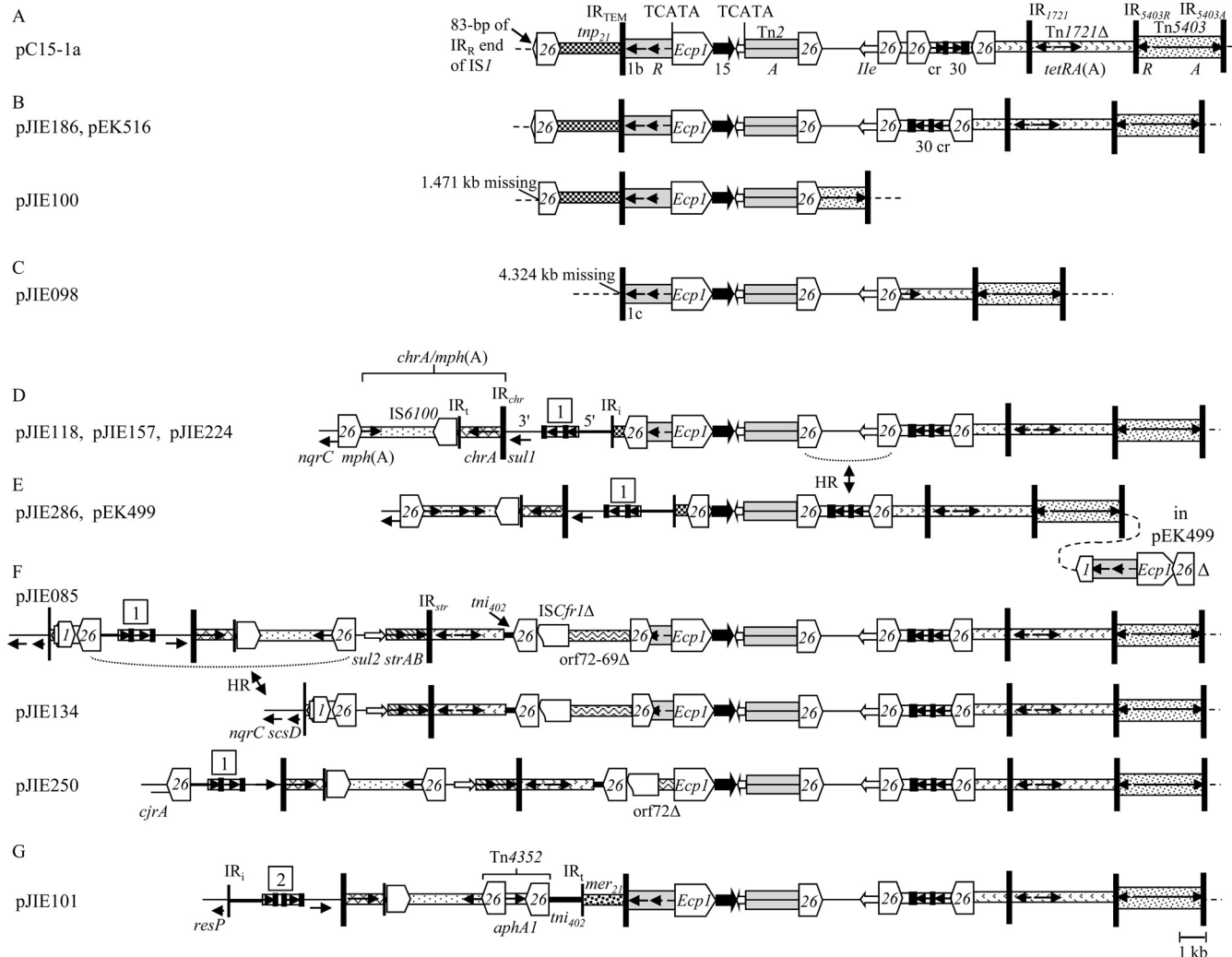

FIG. 1. MRRs carrying *bla*<sub>CTX-M-15</sub>. Similar structures are grouped together. Different transposons and other modules have different shading and are generally labeled only once (*tnp*<sub>21</sub> and *mer*<sub>21</sub>, transposition and mercury resistance regions of Tn21, respectively). ISs are labeled with their number/name, with the pointed end indicating IR<sub>R</sub>. Tall bars represent the 38-bp IR of transposons, as indicated. Positions/orientations of selected resistance and other genes are indicated by arrows, generally labeled only once. Abbreviations: *A*, *tnpA*; *R*, *tnpR*; *1b*, *bla*<sub>TEM-1b</sub>; *1c*, *bla*<sub>TEM-1c</sub>; *15*, *bla*<sub>CTX-M-15</sub>; *Ile*, *aac(3)-Ile*; *cr*, *aac(6′)-Ib-cr*; *30*, *bla*<sub>OXA-30</sub>. Class 1 integron components are indicated as follows: 5′, 5′-CS; 3′, 3′-CS; narrow boxes, gene cassettes; small black boxes, *attC* sites; 1, *dfrA17-aadA5* cassette array; 2, *dfrA12-gcuF-aadA2* cassette array; *tni*<sub>402</sub>, transposition region of Tn402; IR<sub>i</sub>, 25-bp IR at *intI1* end; IR<sub>chr</sub>, 25-bp IR at *tni* end. The *chrA-mph(A)* module (indicated in panel D) is found after position 1593 of the 3′-CS and consists of part of a chromate resistance transposon (IR<sub>chr</sub> and *chrA*), 123 bp of the IR<sub>i</sub> end of *tni*<sub>402</sub>, IS6100, and the *mph(A)-mrx-mphR(A)* macrolide resistance region (29). Dashed lines represent the IncFII backbone. The *nqrC*-like (putative Na<sup>+</sup>-translocating NADH-quinone reductase) and *scsD* (secreted copper sensitivity repressor) genes are part of an ~10-kb region found in several IncF plasmids that is apparently derived from the *Citrobacter koseri* chromosome (GenBank accession no. CP000822). Arrows labeled HR and dotted lines indicate where homologous recombination explains differences between structures. (A) pC15-1a MRR (AY458016). DRs flanking the *ISecp1-bla*<sub>CTX-M-15</sub> transposition unit are shown. The left-hand boundary with the IncFII backbone is defined by a remnant of IS1. (B) Related MRRs in pJIE186, pEK516 (EU935738; rearranged version; see Fig. S3B in the supplemental material), and pJIE100. (C) pJIE098 MRR. (D) pJIE118/pJIE157/pJIE224 MRR. The IR<sub>i</sub>-*tnp*<sub>21</sub> boundary is the same as in Tn21 (AF071413). (E) pJIE286 and pEK499 MRRs. The separate region shown on the right is in pEK499 (EU935739) only. (F) Related MRRs in pJIE085, pJIE134, and pJIE250. IS26 at the end of *chrA-mph(A)* truncates a region derived from IncQ plasmids that includes *sul2* and a truncated Tn5393, carrying the *strAB* genes, and ends with IR<sub>str</sub> (48). This truncates Tn1721, carrying *tetAR(A)*, which is followed by part of *tni*<sub>402</sub> and a region flanked by two copies of IS26 apparently derived from a larger region found in pU302L (AY333434) and pCTX-M3 (AF550415), in which *ISCfr1* and *orf69* are complete. The pJIE085 and pJIE134 MRRs end with a complex multi-IS structure (details in Fig. S5A in the supplemental material), while pJIE250 has IS26 only, truncating the *cjrA* gene found in several plasmids. (G) pJIE101 MRR. *resP* is identical to the genes in IncN plasmids. IS26 at the end of *chrA-mph(A)* forms part of composite transposon Tn4352 (46), the IS26-*tni*<sub>402</sub> boundary is in >30 sequences in GenBank, the IR<sub>i</sub>-*mer*<sub>21</sub> boundary is the same as in Tn21, and the *mer*<sub>21</sub>-IR<sub>TEM</sub> boundary is seen in other plasmid sequences (25, 30).

closely related to pC15-1a and has a similar MRR, while another IncFII plasmid, pEC\_B24 (GU371926), isolated in Belgium, has a simpler MRR and a different backbone (38). The IncFII and IncFIA plasmids pEK499 (EU935739) from the United Kingdom (44) and pEC\_L8 (GU371928) and pEC\_L46 (GU371929) from Belgium (38) are all from ST131 isolates and have related backbones, and all share MRR components with pC15-1a, but the pEC\_L plasmids appear to have been subject to extensive rearrangements (38).

We previously identified *bla*<sub>CTX-M-15</sub> as the dominant ESBL gene in *Enterobacteriaceae* from western Sydney, Australia (50). Transconjugants from 11 different *E. coli* isolates had *bla*<sub>CTX-M-15</sub> and one or more IncF replicons, and here we have determined the structure of the MRRs in the plasmids that they carry. The modular, mosaic nature of MRRs enabled mapping by reference to pC15-1a and other resistance plasmids and limited sequencing. Plasmid backbones were also compared by restriction digestion and sequencing of IncF replicon targets.

(Part of this work was presented at the 48th Interscience Conference on Antimicrobial Agents and Chemotherapy [poster C1-103], Washington, DC, 25 to 28 October 2008.)

#### MATERIALS AND METHODS

**Bacterial strains.** Transconjugants carrying *bla*<sub>CTX-M-15</sub> and IncF replicons from clinical *E. coli* isolates with distinct pulsed-field gel electrophoresis (PFGE) types ( $n = 11$ ) from a collection from western Sydney, Australia, recovered from December 2005 to August 2006 (50) were selected for study. All 11 original isolates were subjected to multilocus sequence typing (MLST; <http://mlst.ucc.ie/mlst/dbs/Ecoli> [43]). Cefotaxime (CTX) and ceftazidime (CAZ) MICs were determined by Etest (AB Biodisk, Solna, Sweden).

**Plasmid analysis.** DNA was prepared for S1 nuclease digestion (3) by embedding bacterial cells ( $10^9$  CFU/ml) in 1% InCert agarose plugs (FMC Bioproducts, Rockland, ME) and treating them with 1 mg/liter proteinase K (Invitrogen, Carlsbad, CA) in ESP buffer (0.5 M EDTA, pH 9, 1% *N*-lauroylsarcosine) at 55°C overnight. After they were washed (once in saline, four times in 1× TE [Tris-EDTA]), the plugs were equilibrated in 200 μl 1× S1 nuclease buffer (room temperature, 20 min; Promega, Madison, WI) and incubated with 8 U S1 nuclease (Promega) in 100 μl buffer (37°C, 45 min), and then 10 μl 0.5 M EDTA (pH 8) was added. PFGE was carried out in 1% PFGE-grade agarose (Bio-Rad, Hercules, CA) or SeaPlaque agarose (GTG Lonza, Rockland, ME) in a CHEF DRII system at 14°C and 6 V/cm with a switch angle of 120° and with a switch time of 5 to 40 s (12 h), followed by 3 to 8 s (8 h), using a MidRange I PFG marker (New England BioLabs, Ipswich, MA). Plasmid bands cut from gels were destained in 1 ml 1× Tris-acetate-EDTA (TAE) buffer at room temperature for 30 min and held overnight at 4°C in 50 μl fresh 1× TAE buffer before fragments were used as templates for replicon PCR. Plasmid DNA was extracted from transconjugants by alkaline lysis (36) and digested with HpaI according to the manufacturer's instructions (New England BioLabs).

**PCR amplification.** Selected primers and reaction conditions are given in Table S1 in the supplemental material. Lysates prepared by incubating a few colonies from a fresh CHROMagar Orientation (CHROMagar, Paris, France) plate in 100 μl water at 95°C for 10 min and centrifuging (1 min, 16,000 × *g*) were used as templates. An Expand Long Template PCR system (Roche Diagnostics, Mannheim, Germany) was used according to the manufacturer's instructions. For inverse PCR (27), outward-facing primers were used with a template created by restricting plasmid DNA with an appropriate enzyme (New England BioLabs) and self-ligating with T4 DNA ligase (New England BioLabs). The FII and FIA amplicons obtained here encompass the regions used in the IncF replicon sequence typing (RST) scheme (41), while the sequences of two IncFIB amplicons were combined to enable RST classification (see Table S1 in the supplemental material).

**Characterizing MRRs carrying *bla*<sub>CTX-M-15</sub>.** PCR mapping was carried out with reference to the pC15-1a MRR and other available MRR sequences (see Fig. S1 and S2 and Table S1 in the supplemental material). ApaI or Sall (New England BioLabs) fragments carrying *bla*<sub>CTX-M-15</sub> from selected plasmids (see Fig. S1 and S2 in the supplemental material) were ligated to pBC SK (Strat-

agene, La Jolla, CA) digested with the same enzyme and used to transform *E. coli* DH5α with selection on chloramphenicol (20 μg/ml) and CTX (8 μg/ml). Sequence adjacent to IR<sub>TEM</sub> in pJIE098 and pJIE101 was obtained using a DNA Walking Speedup kit (Seegene USA, Rockville, MD) and nested primers (see Table S1 in the supplemental material). Direct sequencing of pJIE100 DNA with a primer facing out of the IR<sub>R</sub> end of IS26 gave superimposed sequences. Subtraction of the sequence already identified next to one copy of IS26 gave the sequence adjacent to the other copy. Searches with these sequences identified matching regions in GenBank, and primers were designed to confirm links between regions. Selected regions [e.g., boundaries between potentially mobile segments, *aac*(6')-Ib genes, and replicon PCR products] were sequenced.

**DNA sequencing and analysis.** DNA prepared using PureLink (Invitrogen) Quick Plasmid Miniprep (cloned DNA) or PCR purification (amplicons) kits or treated with 0.65 M NaCl and 5% (wt/vol) polyethylene glycol 8000 for 30 min at 4°C (whole-plasmid DNA) was sequenced at the Westmead DNA facility or Macrogen (Seoul, South Korea). Sequences were assembled and analyzed with Lasergene software (DNASTar Inc., Madison, WI), the Gene Construction Kit program (Textco BioSoftware Inc., West Lebanon, NH), and programs available through <http://www.ncbi.nlm.nih.gov/>.

**Nucleotide sequence accession numbers.** GenBank accession no. EU418920 for pJIE098 has been extended. Partial sequences of other plasmids are available under the following GenBank accession numbers: pJIE100, EU418921; pJIE101, EU418922; pJIE118, EU418924; pJIE134, EU418925; pJIE186, EU418930; pJIE250, EU418932; pJIE085, GU264002; and pJIE286, GU264003.

#### RESULTS AND DISCUSSION

**Strains and plasmids carrying *bla*<sub>CTX-M-15</sub>.** The different *E. coli* isolates carrying *bla*<sub>CTX-M-15</sub> were identified as ST131 ( $n = 7$ ) or ST405 ( $n = 4$ ; Table 1) by MLST. S1 nuclease digestion followed by PFGE (data not shown) of one transconjugant from each isolate revealed a single plasmid in each case (designated pJIE followed by the isolate number), ranging in size from ~70 to ~220 kb (Table 1). Replicon PCR (8, 28) using excised plasmid bands as templates indicated that each plasmid carried all of the replicons previously detected in the corresponding transconjugant (Table 1). The MRR in each plasmid was characterized, and HpaI digest patterns of plasmids and the sequences of IncF replicon PCR products were also compared.

**The MRRs of all 11 pJIE plasmids are related to the pC15-1a MRR.** The IR<sub>R</sub> end of *ISEcp1* had been detected upstream of *bla*<sub>CTX-M-15</sub> in all original isolates (50), and the expected 48-bp spacer was identified in all 11 pJIE plasmids. *ISEcp1* was intact in all except pJIE286, where truncation by IS26 (Fig. 1E) has left only 24 bp of the IR<sub>R</sub> end adjacent to *bla*<sub>CTX-M-15</sub>. This apparently common arrangement (11, 12, 23, 45, 47) separates *bla*<sub>CTX-M-15</sub> from the *ISEcp1* promoter, resulting in reduced resistance to cephalosporins (23, 45), as observed for the JIE286 transconjugant (CTX MIC of 24 μg/ml and CAZ MIC of 3 μg/ml versus CTX and CAZ MICs of >256 μg/ml against other isolates).

The pJIE186 MRR is almost identical to the pC15-1a MRR, except for a rearrangement. The other 10 pJIE plasmids have related MRRs, but various regions are missing compared with pJIE186 and/or extra modules (all previously identified in other MRRs) are present (Fig. 1). One end of the MRR in all 11 plasmids has the same boundary with the plasmid backbone as in pC15-1a.

**IS26-mediated rearrangements and deletions.** In pC15-1a, the *aac*(6')-Ib-cr and *bla*<sub>OXA-30</sub> gene cassettes are associated with two fragments of the *catB3* cassette and three IS26 elements (Fig. 2C). In the 9 pJIE plasmids that include this region (Fig. 1), *aac*(6')-Ib-cr-*bla*<sub>OXA-30</sub>-*catB3Δ* is associated with two



TABLE 1. Characteristics of strains and plasmids carrying *bla*<sub>CTX-M-15</sub>

Plasmid <sup>a</sup>	Strain ST	Size (kb)	Plasmid characteristics							Replicon classified by RST
			<i>bla</i> <sub>TEM</sub>	<i>aac(3)-Ile</i>	<i>aac(6')-Ib-cr</i>	<i>bla</i> <sub>OXA-30</sub>	<i>tetA(A)</i>	MRR <sup>b</sup>	HpaI type <sup>c</sup>	
pC15-1a	ST131?	92	1b	+	+	+	+	1a	A1	F2:A-:B-
<b>pJIE186</b>	ST131	~90	1b	+	+	+	+	1b	A1	F2:A-:B-
pEK516	ST131	64	1b	+	+	+	+	1b	A2	F2:A-:B-
<b>pJIE100</b>	ST131	~75	1b	-	-	-	-	1c	A3	F2:A-:B-
<b>pJIE098</b>	ST405	~145	1c <sup>d</sup>	+	-	-	+ <sup>h</sup>	2	B	F31:A4:B1
<b>pJIE118</b>	ST131	~140	-	+	+	+	+	3a	C1	F2':A1:B-
<b>pJIE157</b>	ST131	~140	-	+	+	+	+	3a	C2	F2':A1:B-
<b>pJIE224</b>	ST131	~140	-	+	+	+	+	3a	C3	F2':A1:B-
pEK499	ST131	118	1b <sup>e</sup>	-	+	+	+	3b		F2:A1:B-
<b>pJIE286</b>	ST131	~170	-	-	+	+	+	3c	D	F2:A1:B-
pEC_L8	ST131	119	1b	-	+ <sup>g</sup>	+ <sup>g</sup>	+ <sup>g</sup>	4		F2':A1:B-
pEC_L46	ST131	145	1b <sup>f</sup>	-	+	+	-	5		F2':A1:B-
<b>pJIE085</b>	ST405	~160	-	+	+	+	+ <sup>g</sup>	6a	E1	F1':A1:B2
<b>pJIE134</b>	ST405	~155	-	+	+	+	+ <sup>g</sup>	6b	E2	F1':A1:B2
<b>pJIE250</b>	ST405	~160	-	+	+	+	+ <sup>g</sup>	6c	E3	F1':A1:B2
<b>pJIE101</b>	ST131	~220	1b	+	+	+	+	7	F	F22:A1:B20 + N

<sup>a</sup> Plasmids with names in boldface were isolated as part of this study. The sequences of previously published plasmids are available under the following GenBank accession numbers: pC15-1a, AY458016; pEK516, EU935738; pEK499, EU935739; pEC\_L8, GU371928; and pEC\_L46, GU371929.

<sup>b</sup> MRRs that could be derived from one other by simple insertions, deletions, or rearrangements are given the same number but different letters.

<sup>c</sup> Similar HpaI patterns are given the same letter but different numbers.

<sup>d</sup> *bla*<sub>TEM-1c</sub> was erroneously designated *bla*<sub>TEM-1j</sub> in reference 50.

<sup>e</sup> The *bla*<sub>TEM-1b</sub> gene is missing 53 bp at the 3' end.

<sup>f</sup> The *bla*<sub>TEM-1b</sub> gene is missing 83 bp at the 5' end, which is found elsewhere on the plasmid.

<sup>g</sup> Two copies of the gene indicated are present.

<sup>h</sup> The *tetA(A)* gene in pJIE098 is truncated by IS26 at the 5' end.

<sup>i</sup> Only 95% identity to pC15-1a/pEK516/pEK499 over the longer region amplified here with primer pair OR1/CA1 (see Table S1 in the supplemental material).

<sup>j</sup> ISEc12 is inserted in RepFII of pJIE085, pJIE134, and pJIE250, while ISEc23 is inserted in RepFII of pRSB107, in each case increasing the size of the amplicon obtained with the OR1/CA1 primer pair (see Table S1 in the supplemental material) by ~2.5 kb.

copies of IS26 and is in the opposite orientation (Fig. 2A). This configuration is also found in pEK499, pEK516, pEC\_L8, and pEC\_L46, although the *catB3* cassette is incorrectly named *catB4* (38, 44). Insertion of an extra copy of IS26 and homol-

ogous recombination between IS26 elements in opposite orientations (Fig. 2) could explain the generation of the pC15-1a configuration, and it seems unlikely that these events would have happened in the reverse order.

pJIE286 and pEK499 lack the *aac(3)-Ile* region found between directly oriented copies of IS26 (Fig. 1D and E), and its presence/absence is readily explained by homologous recombination inserting/deleting a circular molecule containing this region plus one IS26 element (29). pJIE098 and pJIE100 have larger deletions with one end corresponding to IR<sub>R</sub> of IS26, suggesting insertion of an additional copy of IS26 followed by homologous recombination between directly oriented IS26 elements (Fig. 3B and C). The variable associations between *bla*<sub>CTX-M-15</sub> and other resistance genes observed in a number of isolates and plasmids (6, 18, 20, 22, 23, 37, 39) are presumably explained by similar events, particularly in the case of closely related plasmids (21).

**pJIE186 and pJIE100 are closely related to pC15-1a (Canada) and pEK516 (United Kingdom).** Upstream of *bla*<sub>CTX-M-15</sub> the pJIE186 and pC15-1a MRRs have the same boundary with the IncFII backbone (Fig. 1A and B), while in pJIE100 the MRR has a different boundary (Fig. 1B), probably due an IS26-mediated deletion. pJIE186 and pJIE100 have IncFII replicons only and gave amplicons that are identical to both pC15-1a and pEK516 (corresponding to RST allele F2). The predicted pC15-1a and pEK516 HpaI patterns differ (see Fig. S3A in the supplemental material), despite high sequence identity, due to a rearrangement and a deletion (see Fig. S3B in the supplemental material). pJIE186 is indistinguishable from pC15-1a and pJIE100 matches pC15-1a with the appro-

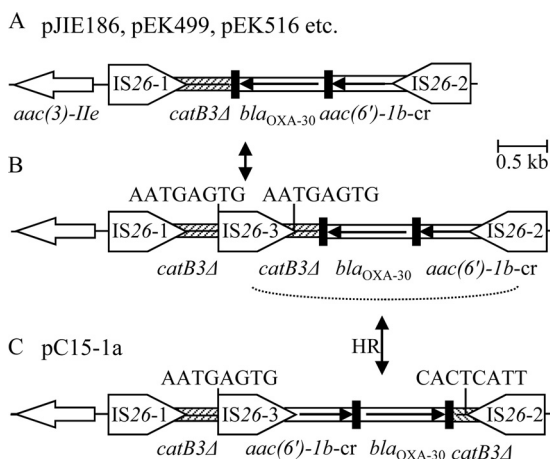

FIG. 2. IS26-mediated rearrangement of the cassette array containing *aac(6')-Ib-cr*, *bla*<sub>OXA-30</sub>, and *catB3Δ*. Components are generally represented as described in the legend to the Fig. 1. (A) Cassette array region in MRRs of pJIE186 and eight other pJIE plasmids, pEK499, pEK516, pEC\_L8, and pEC\_L46; (B) insertion of IS26-3 into the *catB3Δ* cassette would generate 8-bp DRs characteristic of IS26 transposition (9); (C) subsequent homologous recombination between IS26-2 and IS26-3 (dotted line) would invert the intervening region to give the pC15-1a configuration, in which the 8-bp sequence adjacent to IR<sub>L</sub> of IS26-3 is the reverse complement of the 8 bp adjacent to IR<sub>R</sub> of IS26-2.

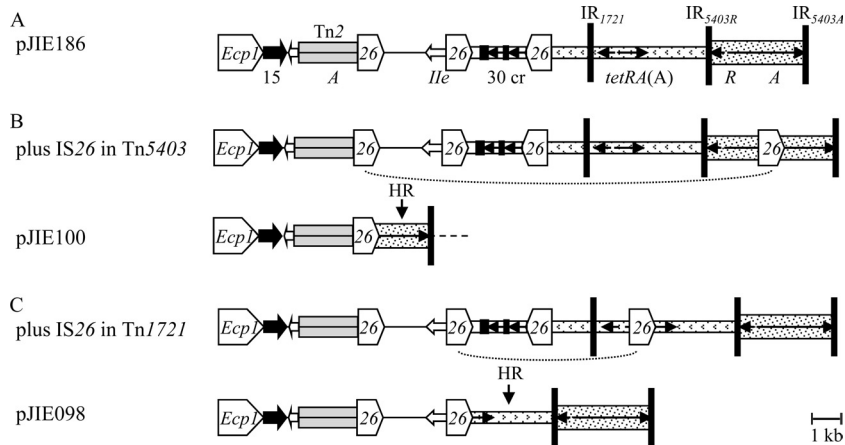

FIG. 3. Deletions in MRRs caused by insertion of additional copies of IS26 and homologous recombination. Components are generally represented as described in the legend to Fig. 1. (A) Part of the pJIE186 MRR; (B) insertion of an extra copy of IS26 in Tn5403 and homologous recombination with the IS26 element interrupting the IR<sub>mp</sub> end of Tn2 (dotted line) would result in the pJIE100 structure; (C) insertion of an extra copy of IS26 in Tn1721 and homologous recombination with the IS26 element next to *aac(3)-Ile* would result in the pJIE098 structure.

appropriate regions deleted, suggesting that these four IncFII plasmids are closely related.

**The pJIE098 MRR may have been created by site-specific recombination in Tn2.** One end of the pJIE098 MRR is defined by the boundary between IR<sub>TEM</sub> and the IncFII backbone (Fig. 1C), but pJIE098 has *bla*<sub>TEM-1c</sub> (15), which has 3 nucleotide differences from *bla*<sub>TEM-1b</sub> (see Fig. S4A in the supplemental material). Other differences from Tn2 suggest that this structure in pJIE098 has arisen by resolvase-mediated site-specific recombination between Tn2a, carrying *bla*<sub>TEM-1c</sub> (1), and Tn2, containing *ISEcp1-bla*<sub>CTX-M-15</sub> (see Fig. S4A in the supplemental material). As Tn3-like transposons exhibit transposition immunity—i.e., the presence of one copy in a DNA molecule significantly reduces insertion of a second copy (16)—these two transposons may have originally been on different plasmids, helping to explain the multiple replicons in pJIE098.

The HpaI pattern of pJIE098 differs from the patterns of the other 10 pJIE plasmids (see Fig. S4B in the supplemental material). The IncFIB amplicon matches pRSB107 (GenBank accession no. AJ851089) (40), designated RST allele B1. The IncFII (F31) and IncFIA (A4) amplicons did not exactly match any sequences in GenBank, but plasmids carrying *bla*<sub>CTX-M-15</sub> from *E. coli* strains from Italy and the United Kingdom were also F31:A4:B1 (41), suggesting that similar plasmids are present in other locations.

**pJIE118, pJIE157, and pJIE224 are closely related.** In the apparently identical MRRs of pJIE118, pJIE157, and pJIE224 the IR<sub>TEM</sub> end of Tn2 is truncated by IS26, which is followed by a class 1 integron with the *dfrA17-aadA5* cassette array and the *chrA-mph(A)* module (29) (Fig. 1D). Slight differences between the HpaI patterns suggest differences in the backbones of these plasmids (see Fig. S3C in the supplemental material), but their IncFIA amplicons are identical, corresponding to allele A1 found in most IncFIA plasmids, including pEC\_L8 and pEC\_L46 (41). The IncFII amplicons of pJIE118, pJIE157, and pJIE224 are also all 100% identical to pEC\_L8 and pEC\_L46, and all these plasmids would be classified as F2 by RST. However, there are significant differences

(~95% identity) from pC15-1a and pEK516, also classified as F2, in the longer region amplified here. Homologous recombination in the ~3-kb region between the Tn5403 end of the MRR and the IncFII replicon could explain this association of the same MRR-backbone boundary with variant replicons.

**pJIE286 is related to pEK499 from the United Kingdom.** The pJIE286 MRR is closely related to the pJIE118/pJIE157/pJIE224 MRR, except that the *aac(3)-Ile* region, *bla*<sub>TEM-1b</sub>, and most of *ISEcp1* are missing (Fig. 1D and E). Like these three plasmids, pJIE286 has allele A1 but a different HpaI pattern (see Fig. S3C in the supplemental material), and the IncFII amplicon is 100% identical to pC15-1a/pEK516 rather than the pEC\_L plasmids. pEK499 has the same MRR as pJIE286 but also includes the remainder of *ISEcp1* and *bla*<sub>TEM-1b</sub> in another inserted region (Fig. 1E). pEK499 also has the same replicon combination as pJIE286, but much of the backbone is 99% identical to the pEC\_L8 and pECL\_46 backbones. This suggests that the IncFII replicon could have been acquired (along with part of the MRR) from a pC15-1a-like plasmid by homologous recombination (see Fig. S3D in the supplemental material). pJIE286 is conjugative, while pEK499 is smaller (Table 1) and nonconjugative, due to a deletion in the *tra* region (44), and PCR confirmed that the region including *bla*<sub>TEM-1b</sub> in pEK499 is not present in pJIE286, but these two plasmids may nevertheless have been generated from the same ancestor by different events.

**The pJIE085, pJIE134, and pJIE250 MRRs: homologous recombination in IS26.** The pJIE085 MRR includes a class 1 integron with *dfrA17-aadA5* and *chrA-mph(A)* plus several other common MRR modules (29), and one end is defined by a complex multi-IS structure that includes IS26 (Fig. 1F; see S4A in the supplemental material). The relationship between this structure and the pJIE134 MRR is readily explained by insertion/release of a circular molecule by homologous recombination in IS26 (Fig. 1F). A region adjacent to *ISEcp1* is missing from the pJIE250 MRR compared with the pJIE085 and pJIE134 MRRs, possibly explained by an *ISEcp1*-mediated deletion. IS26 only, rather than the multi-IS structure, defines the end of the MRR in pJIE250, and the adjacent

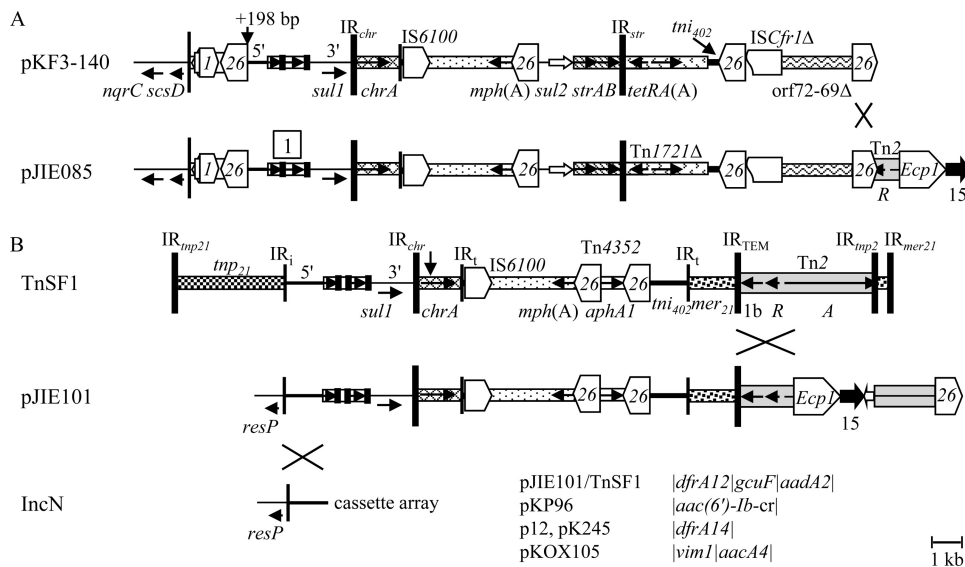

FIG. 4. Recombination between common MRR modules. Components are generally represented as described in the legend to Fig. 1. Crosses indicate regions where homologous recombination could have taken place. (A) Relationship between the pJIE085 and pKF3-140 MRRs. An extra 198 bp of the 5'-CS is present in pKF3-140 compared with pJIE085, as indicated. The IS26 element truncating *orf69* and Tn2 in pJIE085 marks the end of the match to the pKF3-140 MRR. (B) Relationship between the pJIE101 MRR, TnSF1, and IncN plasmids. The vertical arrow in TnSF1 indicates a 521-bp insert not present in any other examples of *chrA-mpH(A)*. The cassette arrays in pJIE101, TnSF1, and IncN plasmids are indicated. The pJIE101 IncN replicon is 100% identical to p12 (14) over the region amplified. Sequences referred to in this diagram are from the following GenBank accession numbers: pKF3-140, FJ876827; TnSF1, AF188331; pKP96, EU195449; p 12, FJ223605; pKOX105, HM126016; and pK245, DQ449578.

backbone region is different, suggesting an IS26-mediated deletion. These variations between MRRs explain some of the differences between large fragments in the HpaI restriction patterns of these plasmids (see Fig. S4B and C in the supplemental material), suggesting that their backbones are closely related.

The pJIE085 MRR matches most of the MRR in pKF3-140 from a *Klebsiella pneumoniae* isolate from China (49) (Fig. 4A). Recombination between IS26 elements that define the end of this match could have brought these regions together, or the two smaller MRRs could have been created from the larger one by the reverse process. The RST formula of pKF3-140 (F1:A2:B2) is different from that of pJIE085, pJIE134, and pJIE250 (F1:A1:B2), but alleles A1 and A2 have only 1 nucleotide difference, and there is only one additional difference in the longer IncFIA region amplified, suggesting a close relationship between these four plasmids.

**The pJIE101 MRR: homologous recombination in Tn2.** The pJIE101 MRR includes a class 1 integron and *chrA-mpH(A)*, but with the *dfrA12-gcuF-aadA2* cassette array (Fig. 1G). The whole of the region upstream of *ISEcp1* matches TnSF1, and homologous recombination between Tn2 elements in a pJIE186-like MRR and a TnSF1-like structure would link these regions to create the MRR seen in pJIE101 (Fig. 4B).

pJIE101 apparently has an IncN replicon in addition to IncFII, FIA, and FIB. Consistent with this one end of the MRR, marked by IR<sub>i</sub> (the 25-bp IR at the *intI1* end of class 1 integrons), has the same boundary with the *resP* region as in several IncN plasmids with class 1 integrons and different cassette arrays (Fig. 4B). Homologous recombination, in this case, between two copies of the 5' conserved sequence (5'-CS), again readily explains the association of the IncN *resP* region

with the remainder of the MRR. Other plasmids also have both IncF and IncN replicons: pEC\_L46 (38) includes a region matching part of the IncN plasmid 9 (GenBank accession no. FJ223607) (14) that contains the IncN replicon, and pGSH500 from *K. pneumoniae* also has both IncFII-like and IncN-like replicons (28).

The pJIE101 HpaI pattern differs from those of the other 10 pJIE plasmids (see Fig. S4C in the supplemental material), and the IncFIA amplicon matches many plasmids in GenBank, while the IncFII and IncFIB amplicons had no exact matches. The same RST combination as pJIE101 (F22:A1:B20) was also detected in plasmids carrying *bla*<sub>CTX-M-15</sub> from *E. coli* strains from Italy and the United Kingdom (41), which apparently do not have an IncN replicon.

**Concluding remarks.** In the IncF plasmids from Sydney studied here, the *bla*<sub>CTX-M-15</sub> gene is located in closely related MRRs that are also related to those on plasmids from several other geographic locations. Differences in the combinations of certain resistance genes co-occurring with *bla*<sub>CTX-M-15</sub> appear to reflect deletions/insertions of parts of a common MRR, often mediated by IS26, rather than the presence of significantly different MRRs. We found no evidence of movement of a discrete MRR between different plasmids; rather, it appears that different MRRs have been constructed by recombination between elements that are common in these regions (IS26 and Tn2) acting as adaptors. The location of *bla*<sub>CTX-M-15</sub> in large MRRs that also carry common modules and mobile elements that enable recombination and reassortment may be a principal contributor to its success.

Mapping of MRRs containing *bla*<sub>CTX-M-15</sub> was possible because all of the components identified had been seen before in sequences available in GenBank, often in the same combina-



tions with the same boundaries, for example, *sul2-strAB* (>50 sequences), the IS26-*tni*<sub>402</sub> boundary in pJIE101 (>30 sequences), and the *chrA-mpH(A)* module (>10 examples). The two cassette arrays identified also appear to be very common (31), suggesting that they are traveling as part of larger structures. This further illustrates that MRRs are mosaics of modules already available in the gene pool (2, 29, 42).

One boundary of the MRR with plasmid backbone was the same in all plasmids studied here and in other available sequences, even in plasmids carrying different combinations and variants of IncF replicons. Recombination in plasmid backbones, in addition to MRRs, thus appears to contribute to the creation of multiple replicon IncF plasmids. Such mosaicism hampers the development of robust methods for classifying and comparing IncF plasmids. Depending on the target sequences chosen, RST-type classification schemes can underestimate diversity (e.g., F2 plasmids may have differences over a longer region) and single nucleotide changes may overemphasize differences (e.g., IncFIA of pKF3-140). RST of IncF plasmids may thus be a useful starting point for grouping plasmids and identifying similarities between those from different locations, but it needs to be combined with other methods (restriction digests, MRR mapping) to characterize plasmids.

Use of such a combination of methods should allow identification of the most informative sets of multi-IncF plasmids to completely sequence, to aid in understanding the processes involved in their generation and evolution, and in developing improved classification schemes. Characterization of IncF plasmids carrying *bla*<sub>CTX-M-15</sub> from a range of locations may shed light on how such plasmids spread, and characterization of plasmids from different strain types may help to elucidate relationships between particular plasmids and strains, suggested here by differences between pJIE plasmids from ST405 and ST131 isolates. Characterization of many plasmids carrying *bla*<sub>CTX-M-15</sub> from places where they are long established and/or highly prevalent may help to determine whether variety increases with time or whether a limited number of dominant structures/plasmids emerge, which has important implications for our understanding of natural selection within the mobile antibiotic resistance gene pool.

#### ACKNOWLEDGMENTS

We thank Andrew Ginn for technical assistance.

Z.Z. was supported by an Endeavor International Postgraduate Research Scholarship from the Australian Government Department of Education, Science and Training. S.R.P. was partly supported by grant 512396 from the Australian National Health and Medical Research Council. This study made use of the *E. coli* MLST database (<http://mlst.ucc.ie/mlst/dbs/Ecoli>), which is currently supported by a grant from the Science Foundation of Ireland (05/FE1/B882).

#### REFERENCES

- Bailey, J. K., J. L. Pinyon, S. Anantham, and R. M. Hall. 2011. Distribution of the *bla*<sub>TEM</sub> gene and *bla*<sub>TEM</sub>-containing transposons in commensal *Escherichia coli*. *J. Antimicrob. Chemother.* **66**:745–751.
- Baquero, F. 2004. From pieces to patterns: evolutionary engineering in bacterial pathogens. *Nat. Rev. Microbiol.* **2**:510–518.
- Barton, B. M., G. P. Harding, and A. J. Zuccarelli. 1995. A general method for detecting and sizing large plasmids. *Anal. Biochem.* **226**:235–240.
- Baudry, P. J., et al. 2009. Mechanisms of resistance and mobility among multidrug-resistant CTX-M-producing *Escherichia coli* from Canadian intensive care units: the 1st report of QepA in North America. *Diagn. Microbiol. Infect. Dis.* **63**:319–326.
- Bonnet, R. 2004. Growing group of extended-spectrum  $\beta$ -lactamases: the CTX-M enzymes. *Antimicrob. Agents Chemother.* **48**:1–14.
- Boyd, D. A., et al. 2004. Complete nucleotide sequence of a 92-kilobase plasmid harboring the CTX-M-15 extended-spectrum beta-lactamase involved in an outbreak in long-term-care facilities in Toronto, Canada. *Antimicrob. Agents Chemother.* **48**:3758–3764.
- Cantón, R., and T. M. Coque. 2006. The CTX-M  $\beta$ -lactamase pandemic. *Curr. Opin. Microbiol.* **9**:466–475.
- Carattoli, A., et al. 2005. Identification of plasmids by PCR-based replicon typing. *J. Microbiol. Methods* **63**:219–228.
- Chandler, M., and J. Mahillon. 2002. Insertion sequences revisited, p. 306–367. *In* N. L. Craig, R. Cragie, M. Gellert, and A. M. Lambowitz (ed.), *Mobile DNA*. ASM Press, Washington, DC.
- Coque, T. M., et al. 2008. Dissemination of clonally related *Escherichia coli* strains expressing extended-spectrum  $\beta$ -lactamase CTX-M-15. *Emerg. Infect. Dis.* **14**:195–200.
- Cullik, A., Y. Pfeifer, R. Prager, H. von Baum, and W. Witte. 2010. A novel IS26 structure is surrounding *bla*<sub>CTX-M</sub> genes in different plasmids of German clinical isolates of *Escherichia coli*. *J. Med. Microbiol.* **59**:580–587.
- Diestra, K., et al. 2009. Characterization of plasmids encoding *bla*<sub>ESBL</sub> and surrounding genes in Spanish clinical isolates of *Escherichia coli* and *Klebsiella pneumoniae*. *J. Antimicrob. Chemother.* **61**:60–66.
- Eckert, C., V. Gautier, and G. Arlet. 2006. DNA sequence analysis of the genetic environment of various *bla*<sub>CTX-M</sub> genes. *J. Antimicrob. Chemother.* **57**:14–23.
- Gootz, T. D., et al. 2009. Genetic organization of transposase regions surrounding *bla*<sub>KPC</sub> carbapenemase genes on plasmids from *Klebsiella* strains isolated in a New York City hospital. *Antimicrob. Agents Chemother.* **53**:1998–2004.
- Goussard, S., and P. Courvalin. 1999. Updated sequence information for TEM  $\beta$ -lactamase genes. *Antimicrob. Agents Chemother.* **43**:367–370.
- Grindley, N. D. F. 2002. The movement of Tn3-like elements: transposition and cointegrate resolution, p. 272–302. *In* N. L. Craig, R. Cragie, M. Gellert, and A. M. Lambowitz (ed.), *Mobile DNA II*. ASM Press, Washington, DC.
- Hopkins, K. L., et al. 2006. Replicon typing of plasmids carrying CTX-M or CMY  $\beta$ -lactamases circulating among *Salmonella* and *Escherichia coli* isolates. *Antimicrob. Agents Chemother.* **50**:3203–3206.
- Karisik, E., et al. 2006. Molecular characterization of plasmids encoding CTX-M-15  $\beta$ -lactamases from *Escherichia coli* strains in the United Kingdom. *J. Antimicrob. Chemother.* **58**:665–668.
- Lartigue, M. F., L. Poirel, D. Aubert, and P. Nordmann. 2006. In vitro analysis of ISEcp1B-mediated mobilization of naturally occurring  $\beta$ -lactamase gene *bla*<sub>CTX-M</sub> of *Kluyvera ascorbata*. *Antimicrob. Agents Chemother.* **50**:1282–1286.
- Lavollay, M., et al. 2006. Clonal dissemination of a CTX-M-15  $\beta$ -lactamase-producing *Escherichia coli* strain in the Paris area, Tunis, and Bangui. *Antimicrob. Agents Chemother.* **50**:2433–2438.
- Leflon-Guibout, V., et al. 2004. Emergence and spread of three clonally related virulent isolates of CTX-M-15-producing *Escherichia coli* with variable resistance to aminoglycosides and tetracycline in a French geriatric hospital. *Antimicrob. Agents Chemother.* **48**:3736–3742.
- Machado, E., et al. 2006. Dissemination in Portugal of CTX-M-15-, OXA-1-, and TEM-1-producing *Enterobacteriaceae* strains containing the *aac(6')-Ib-cr* gene, which encodes an aminoglycoside- and fluoroquinolone-modifying enzyme. *Antimicrob. Agents Chemother.* **50**:3220–3221.
- Montesinos, I., et al. 2010. Molecular characterization of plasmids encoding CTX-M-15 extended-spectrum  $\beta$ -lactamase associated with the ST131 *Escherichia coli* clone in Belgium. *J. Antimicrob. Chemother.* **65**:1828–1830.
- Nicolas-Chanoine, M. H., et al. 2008. Intercontinental emergence of *Escherichia coli* clone O25:H4-ST131 producing CTX-M-15. *J. Antimicrob. Chemother.* **61**:273–281.
- Novais, A., et al. 2010. International spread and persistence of TEM-24 is caused by the confluence of highly penetrating *Enterobacteriaceae* clones and an IncA/C2 plasmid containing Tn1696::Tn1 and IS5075-Tn21. *Antimicrob. Agents Chemother.* **54**:825–834.
- Novais, A., et al. 2006. Emergence and dissemination of *Enterobacteriaceae* isolates producing CTX-M-1-like enzymes in Spain are associated with IncFII (CTX-M-15) and broad-host-range (CTX-M-1, -3, and -32) plasmids. *Antimicrob. Agents Chemother.* **51**:796–799.
- Ochman, H., A. S. Gerber, and D. L. Hartl. 1988. Genetic applications of an inverse polymerase chain reaction. *Genetics* **120**:621–623.
- Osborn, A. M., F. M. da Silva Tatley, L. M. Steyn, R. W. Pickup, and J. R. Saunders. 2000. Mosaic plasmids and mosaic replicons: evolutionary lessons from the analysis of genetic diversity in IncFII-related replicons. *Microbiology* **146**:2267–2275.
- Partridge, S. R. 2011. Analysis of antibiotic resistance regions in Gram-negative bacteria. *FEMS Microbiol. Rev.* **35**:820–855.
- Partridge, S. R., and R. M. Hall. 2004. Complex multiple antibiotic and mercury resistance region derived from the r-det of NR1 (R100). *Antimicrob. Agents Chemother.* **48**:4250–4255.
- Partridge, S. R., G. Tsafnat, E. Coiera, and J. R. Iredell. 2009. Gene cassettes and cassette arrays in mobile resistance integrons. *FEMS Microbiol. Rev.* **33**:757–784.
- Peirano, G., and J. D. Pitout. 2010. Molecular epidemiology of *Escherichia*

- coli* producing CTX-M  $\beta$ -lactamases: the worldwide emergence of clone ST131 O25:H4. *Int. J. Antimicrob. Agents* **35**:316–321.
33. **Poirel, L., J. W. Decousser, and P. Nordmann.** 2003. Insertion sequence *ISEcp1B* is involved in expression and mobilization of a *bla*<sub>CTX-M</sub>  $\beta$ -lactamase gene. *Antimicrob. Agents Chemother.* **47**:2938–2945.
  34. **Poirel, L., M. F. Lartigue, J. W. Decousser, and P. Nordmann.** 2005. *ISEcp1B*-mediated transposition of *bla*<sub>CTX-M</sub> in *Escherichia coli*. *Antimicrob. Agents Chemother.* **49**:447–450.
  35. **Rogers, B. A., H. E. Sidjabat, and D. L. Paterson.** 2010. *Escherichia coli* O25b-ST131: a pandemic, multiresistant, community-associated strain. *J. Antimicrob. Chemother.* **66**:1–14.
  36. **Sambrook, J., and D. W. Russell.** 2001. *Molecular cloning: a laboratory manual*, 2nd ed. Cold Spring Harbor Laboratory Press, Cold Spring Harbor, NY.
  37. **Sidjabat, H. E., et al.** 2009. Molecular epidemiology of CTX-M-producing *Escherichia coli* isolates at a tertiary medical center in western Pennsylvania. *Antimicrob. Agents Chemother.* **53**:4733–4739.
  38. **Smet, A., et al.** 2010. Complete nucleotide sequence of CTX-M-15-plasmids from clinical *Escherichia coli* isolates: insertional events of transposons and insertion sequences. *PLoS One* **5**:e11202.
  39. **Soge, O. O., A. M. Queenan, K. K. Ojo, B. A. Adeniyi, and M. C. Roberts.** 2006. CTX-M-15 extended-spectrum  $\beta$ -lactamase from Nigerian *Klebsiella pneumoniae*. *J. Antimicrob. Chemother.* **57**:24–30.
  40. **Szczepanowski, R., et al.** 2005. The 120 592 bp IncF plasmid pRSB107 isolated from a sewage-treatment plant encodes nine different antibiotic-resistance determinants, two iron-acquisition systems and other putative virulence-associated functions. *Microbiology* **151**:1095–1111.
  41. **Villa, L., A. Garcia-Fernandez, D. Fortini, and A. Carattoli.** 2010. Replicon sequence typing of IncF plasmids carrying virulence and resistance determinants. *J. Antimicrob. Chemother.* **65**:2518–2529.
  42. **Walsh, T. R.** 2006. Combinatorial genetic evolution of multiresistance. *Curr. Opin. Microbiol.* **9**:476–482.
  43. **Wirth, T., et al.** 2006. Sex and virulence in *Escherichia coli*: an evolutionary perspective. *Mol. Microbiol.* **60**:1136–1151.
  44. **Woodford, N., et al.** 2009. Complete nucleotide sequences of plasmids pEK204, pEK499, and pEK516, encoding CTX-M enzymes in three major *Escherichia coli* lineages from the United Kingdom, all belonging to the international O25:H4-ST131 clone. *Antimicrob. Agents Chemother.* **53**:4472–4482.
  45. **Woodford, N., et al.** 2004. Community and hospital spread of *Escherichia coli* producing CTX-M extended-spectrum  $\beta$ -lactamases in the UK. *J. Antimicrob. Chemother.* **54**:735–743.
  46. **Wrighton, C. J., and P. Strike.** 1987. A pathway for the evolution of the plasmid NTP16 involving the novel kanamycin resistance transposon Tn4352. *Plasmid* **17**:37–45.
  47. **Xu, L., et al.** 2011. Regional survey of CTX-M-type extended-spectrum  $\beta$ -lactamases among Enterobacteriaceae reveals marked heterogeneity in the distribution of the ST131 clone. *J. Antimicrob. Chemother.* **66**:505–511.
  48. **Yau, S., X. Liu, S. P. Djordjevic, and R. M. Hall.** 2010. RSF1010-like plasmids in Australian *Salmonella enterica* serovar Typhimurium and origin of their *sul2-strA-strB* antibiotic resistance gene cluster. *Microb. Drug Resist.* **16**:249–252.
  49. **Zhao, F., et al.** 2010. Sequencing and genetic variation of multidrug resistance plasmids in *Klebsiella pneumoniae*. *PLoS One* **5**:e10141.
  50. **Zong, Z., S. R. Partridge, L. Thomas, and J. R. Iredell.** 2008. Dominance of *bla*<sub>CTX-M</sub> within an Australian extended-spectrum  $\beta$ -lactamase gene pool. *Antimicrob. Agents Chemother.* **52**:4198–4202.