

# Erythrocytosis Associated with Hemoglobin Rainier: Oxygen Equilibria and Marrow Regulation

JOHN W. ADAMSON, JULIAN T. PARER, and GEORGE STAMATOYANNOPOULOS,  
with the technical assistance of S. HEINENBERG

*From the Divisions of Hematology and Medical Genetics, Department of Medicine, and the Department of Obstetrics and Gynecology, University of Washington School of Medicine, Seattle, Washington 98105*

**ABSTRACT** Hemoglobin Rainier ( $\beta^{146}$  tyrosine  $\rightarrow$  histidine) is an abnormal hemoglobin associated with increased oxygen affinity, decreased heme-heme interaction, presence of a Bohr effect, and erythrocytosis, but without obvious clinical sequelae.

Regulation of erythropoiesis was studied in affected members of families having either hemoglobin Rainier or Yakima, abnormal hemoglobins associated with erythrocytosis.

Apart from the elevated but stable hemoglobin concentration and red cell mass, parameters of red cell production in the subjects were normal. Initially normal values of erythropoietin excretion were increased by phlebotomy indicating a significant hypoxic stress at an otherwise normal hematocrit. This stress led to increased reticulocyte production and an eventual return to the prephlebotomy hematocrit. The erythrocytosis in carriers of hemoglobins Rainier and Yakima appears to be secondary to the increased oxygen affinity and this, with the response to phlebotomy, is consistent with the postulate that the renal sensor tissue regulating erythropoietin production is primarily influenced by the oxygen tensions of venous rather than arterial blood.

## INTRODUCTION

The oxygen tension of blood at some site in the kidney is probably the critical factor regulating red blood cell production (1). This regulation is mediated by erythropoietin which acts upon bone marrow to produce differ-

entiation and proliferation of precursor cells along erythroid lines (2-5). Evidence for the role of erythropoietin in the regulation of normal erythropoiesis is provided by its presence in normal urine (6-8) and its predictable variation with small changes in hematocrit (9). A number of clinical situations, most frequently associated with cardiac and pulmonary dysfunction, result in arterial hypoxemia, increased erythropoietin production, and eventual erythrocytosis (10-12). In addition, erythrocytosis has been linked recently to abnormal human hemoglobins having increased oxygen affinity. At present five such human hemoglobins have been described: hemoglobins Chesapeake (13), Ypsi (14), Yakima (15, 16), Kempsey (17), and Hiroshima (18). Structural data on a sixth hemoglobin with increased oxygen affinity, designated as hemoglobin Rainier, have also been reported (19). The biochemical abnormality in hemoglobin Rainier is located near the C-terminal end of the polypeptide chain and represents a substitution of the invariant  $\beta^{146}$  tyrosine by histidine. This substitution also renders the hemoglobin Rainier molecule resistant to denaturation by alkali, the first example of an adult human hemoglobin variant characterized by abnormal alkali denaturation kinetics.

This report describes erythropoietin studies, oxygen-hemoglobin equilibria, the family study, and further biochemical characteristics of hemoglobin Rainier. In addition, erythropoietin studies are described in two subjects with hemoglobin Yakima (15, 16).

## METHODS

*Hematologic and hemoglobin studies.* Hematologic measurements were made with standard techniques. Red cell mass was measured in the proposita with hemoglobin Rainier using  $^{51}\text{Cr}$ -labeled autologous cells (20). Hemolysates were prepared by a modification of the method of Drabkin (21).

This work was presented in part at the meeting of the American Society of Hematology, Toronto, Canada, December, 1967.

Dr. Adamson's present address is Hematology Section, Clinical Pathology Department, National Institutes of Health, Bethesda, Md. 20014.

Received for publication 2 December 1968 and in revised form 3 March 1969.

TABLE I  
Hematologic and Hemoglobin Data in Hemoglobin Rainier Family

Case	Age	Sex	Hb Rainier	P <sub>50</sub> * mmHg	O <sub>2</sub> capacity ml/100 ml	Hb g/100 ml	Hemato- crit	RBC Count × 10 <sup>3</sup> /mm <sup>3</sup>	Reticulo- cytes %	Per cent of alkali- resistant hemoglobin %
I-1	47	F	+	11.9		16.7	52.0	5049	1.0	16.8
II-2	28	F	+	13.1	22.0	16.4	53.0	5650	1.8	12.6
II-4	25	F	-	30.6	15.8	11.8	36.0	3960	3.2	0.2
II-5	24	M	+	11.3	28.2	21.0	60.0	6600	1.2	15.0
II-7	23	F	+	13.5	21.7	16.2	51.0	5600	2.2	14.0
III-1	10	M	-	—	17.7	13.2	40.0	4700	0.9	0.3
III-3	8	F	+	14.6	21.6	16.1	49.0	5040	1.2	15.0
III-4	4	F	+	13.5	21.4	16.0	46.0	5230	1.8	16.5
III-5	3	M	-	31.1	16.6	12.4	38.0	4330	0.8	0.2
III-7	3	M	-	—	16.5	12.3	37.0	5200	1.0	0.1
III-9	2	M	+	12.7	20.0	14.9	44.0			
III-10	70 days	F	-	30.5	12.3	9.2	29.0			

\* P<sub>50</sub> = oxygen tension of whole blood at 50% saturation (pH 7.40 and 38°C).

Hemoglobin electrophoresis on agar gel was performed with 0.05 M citrate buffer at pH 6.2 (22). Hemoglobin A<sub>2</sub> was quantitated by diethylaminoethyl (DEAE)-Sephadex chromatography using Tris-HCl buffer with a pH gradient from pH 8.3 to 7.1. Hemoglobin Rainier was separated and quantitated by carboxymethylcellulose (CM)-Sephadex column chromatography with 0.05 M phosphate buffer at pH 6.0 and a linear NaCl gradient from 0.0 to 0.15 moles/liter. Alkali denaturation rates were determined by the technique of Jonxis and Visser (23) and the method of Betke, Marti, and Shlicht (24) in those individuals without an increase in alkali-resistant hemoglobin. Hemoglobin thermostability was studied in hemolysates in 0.05 M phosphate buffer at pH 7.0; the undenatured hemoglobin was quantitated as cyanmethemoglobin after exposure of hemolysates for 2 min to a gradient of temperatures ranging from 37° to 100°C and after exposure to 60°C for 12 hr. The spectra of oxy-hemoglobin in an unfractionated hemolysate and of acidic and alkaline methemoglobin Rainier and methemoglobin A were determined in both Beckman D.U. and Cary recording spectrophotometers.

*Oxygen-hemoglobin equilibrium curves of whole blood.* Oxygen equilibrium curves were determined in venous blood of seven individuals with hemoglobin Rainier. The blood was drawn into syringes containing 5% sodium fluoride in heparin solution (1000 IU/ml) in the dead space. All determinations on whole blood were completed within 8 hr of blood withdrawal. Two aliquots of each sample were exposed in rotating glass vessels for at least 70 min at 38°C to a constant stream of gases containing 25% and 0% oxygen, respectively, in 6% carbon dioxide and nitrogen. Known quantities of each sample were mixed thoroughly anaerobically, and the oxygen tension and pH measured after 2-5 min at 38°C with Radiometer electrodes. The zero point of the oxygen electrode was determined with sulfite in borax solution, and the scale was calibrated with a gas containing approximately 5% oxygen accurately analyzed by the method of Scholander (25). Complete deoxygenation of blood containing hemoglobin Rainier in the 0% oxygen tonometer could not be attained within a practical time, so the oxygen content of the blood was measured by the Van Slyke-Neill

manometric apparatus at different times during tonometry. The per cent saturation was calculated from a knowledge of the amount of oxygen in the "deoxygenated" sample, the equilibrium oxygen tension, and the hemoglobin concentration of the blood (26). In two subjects, points on the oxygen equilibrium curve were also determined by the following technique (27). Blood was exposed for at least 45 min to gases of known oxygen partial pressure, the oxygen concentration and oxygen capacity measured by the Van Slyke-Neill apparatus, and the per cent saturation calculated. The pH was measured with a Radiometer electrode. In all cases blood was checked for hemolysis after tonometry by visual examination of plasma. The pH of the blood samples after tonometry with 6% carbon dioxide ranged from 7.280 to 7.433. The oxygen tensions were corrected to their values at 7.40 by use of a Bohr effect factor of -0.48.

The Bohr effect ( $\Delta \log P_{O_2} / \Delta \text{pH}$ ) was determined in whole blood after equilibration of aliquots of blood with gas mixtures of approximately 3, 6, and 12% carbon dioxide, respectively, and measurement of the shift of the oxygen equilibrium curve. Oxygen capacity was determined either by measurement of the oxygen content of blood after equilibration with a gas mixture containing 25% oxygen or by calculation from the hemoglobin content (determined spectrophotometrically as cyanmethemoglobin) assuming 1 g of hemoglobin combined with 1.34 cc of oxygen. The pH of packed red blood cells was determined immediately after hemolyzing them anaerobically by a freeze-thaw method (28). The relationship between plasma pH and red cell pH was determined at a number of different pH's and regression lines were calculated.

*Oxygen equilibria of hemoglobin solutions.* These were performed on unfractionated hemolysates prepared from freshly drawn blood from normal controls and two individuals with hemoglobin Rainier, and also on hemoglobins Rainier and A isolated with CM-Sephadex chromatography. The hemoglobin solutions were dialyzed at 4°C for 24 hr against 0.05 M phosphate buffer at pH 6.5. The oxygen equilibrium curves were constructed with the above mentioned mixing technique at hemoglobin concentrations of 3.0-5.4 g/100 ml. They were done at a water bath tempera-

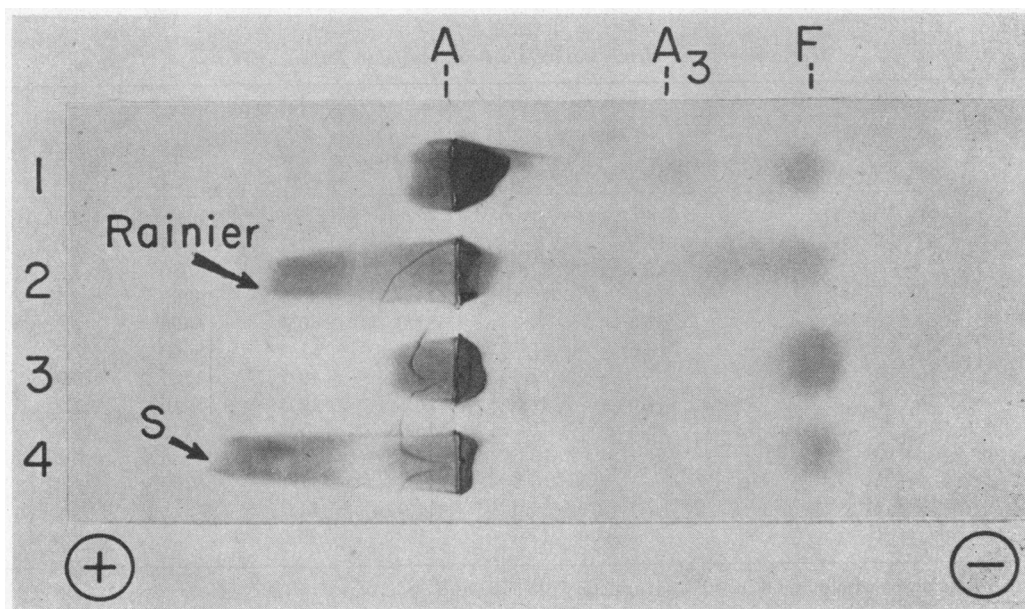

FIGURE 1 Hemoglobin electrophoresis on agar (pH 6.2) stained by buffered benzidine for 1 min and subsequently by amido black. 1, normal control; 2, Hb Rainier heterozygote; 3, control with 4% Hb F; and 4, sickle-cell trait.

ture of 33°C and a carbon dioxide partial pressure of approximately 40 mm Hg. The final pH of the samples was 6.30. Aliquots of the isolated hemoglobins were dialyzed at 4° for 24 hr against 0.05 M phosphate buffers at pH 6.5 and 7.4, to determine the Bohr effect factors. Methemoglobin concentrations were measured in the samples after dialysis and tonometry by the method of Evelyn and Malloy (29).

*Studies of erythropoiesis regulation.* Factors regulating red cell production were characterized in the proposita with hemoglobin Rainier (case I-1), and in the 15 yr old daughter of the propositus with hemoglobin Yakima. Iron kinetics were measured by labeling the patients' serum with 5-10  $\mu$ c of  $^{59}\text{Fe}$ , previously converted to the ferrous salt with 4% sodium citrate, and injecting the label intravenously (30). Per cent utilization and erythrocyte iron turnover

were measured at 14 days. The reticulocyte count, corrected for hematocrit (30), was determined by screening the equivalent of 10,000 red cells using the Miller ocular (31). Urinary erythropoietin was measured over a 4 day period and then averaged to establish baseline excretion. Midway in the course of study an exchange phlebotomy was carried out which was designed to lower the hematocrit by about 10 points. Blood removed was partially replaced with 5% albumin solution; no untoward effects were observed. The erythropoietic response to the phlebotomy was monitored for 4-5 days by measurements of hematocrit, reticulocyte index, and erythropoietin excretion.

In addition, urine was collected on 2 separate days from the propositus with hemoglobin Yakima. At the time of sampling, the patient's hematocrit was 47.5 and had been

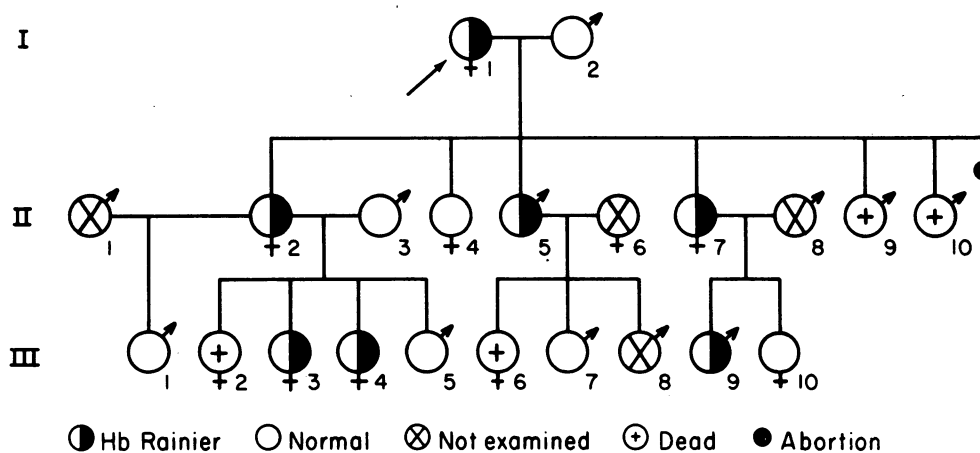

FIGURE 2 Pedigree of the proposita, C. B., with hemoglobin Rainier.

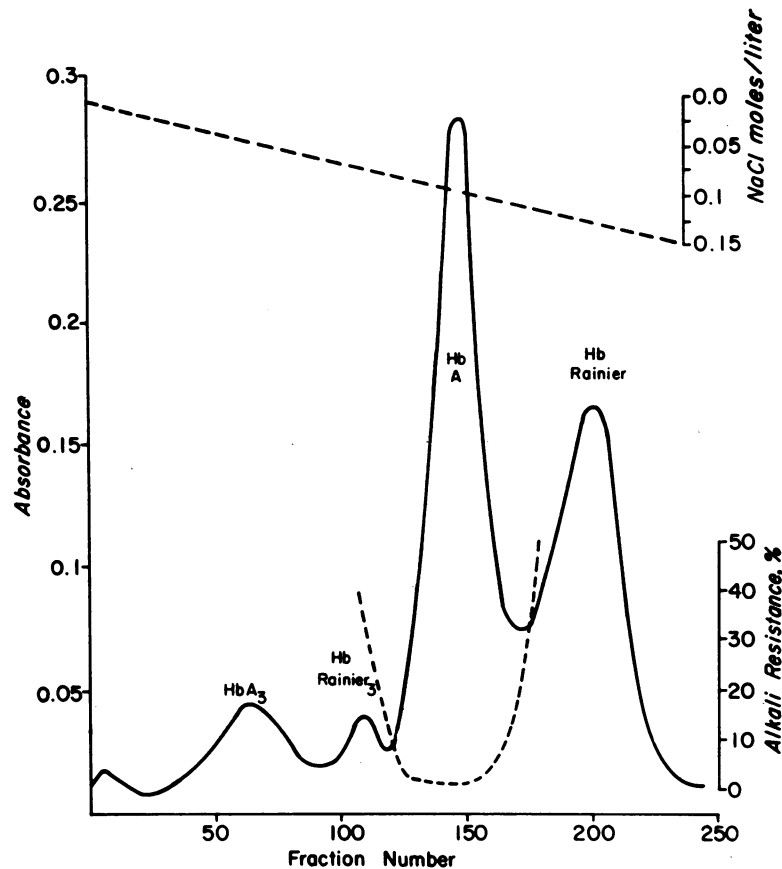

FIGURE 3 Separation of Hb Rainier from Hb A by CM-Sephadex chromatography.

essentially normal after a course of  $^{32}\text{P}$  therapy 2 yr previously (15).

Urines for erythropoietin determinations were collected in consecutive 24-hr lots. Each specimen was frozen immediately upon voiding and stored at  $-20^{\circ}\text{C}$  until thawed in preparation for assay. One-fourth of each 24 hr pool (equivalent to a 6 hr aliquot) was concentrated (9) and assayed in ex-hypoxic polycythemic mice maintained on a protein-depletion diet (6). Erythropoietin was quantitated by comparing the response of groups of mice receiving urine concentrates with those receiving known amounts of erythropoietin Standard B. Saline-injected animals served as controls.

## RESULTS

The proposita, a 47 yr old Caucasian female, was admitted to the Clinical Research Center, University Hospital, Seattle, Washington, in 1967, for evaluation of presumed polycythemia vera, first diagnosed 2 yr before. She had previously been treated by phlebotomy and  $^{32}\text{P}$  radiotherapy. Family history was significant in that two brothers and the maternal grandmother were alleged to have "thick blood." Physical examination revealed only mild plethora; the spleen and liver were not en-

larged. Hematologic values are found in Table I. Leukocyte, differential, and reticulocyte and platelet counts were normal. Bone marrow aspiration revealed only mild erythroid hyperplasia. Analysis of blood revealed no arterial hypoxemia (arterial oxygen tension, 88 mm Hg at pH 7.4).

A hemoglobin abnormality was suspected when it was found that whole blood from the patient had increased oxygen affinity and the hemolysate had increased alkali resistance in the absence of fetal hemoglobin. Hemoglobin Rainier was subsequently demonstrated by agar-gel electrophoresis (Fig. 1).

Further studies revealed that among the children and grandchildren of the proposita (Fig. 2, Table I) six had mild erythrocytosis associated with hemoglobin Rainier. Besides mild rubor, none of them had clinical findings or symptomatology which could be directly attributed to the presence of the abnormal hemoglobin.

*Studies on hemoglobin Rainier.* In addition to agar-gel electrophoresis in citrate buffer at pH 6.2, hemoglobin Rainier was resolved from hemoglobin A by

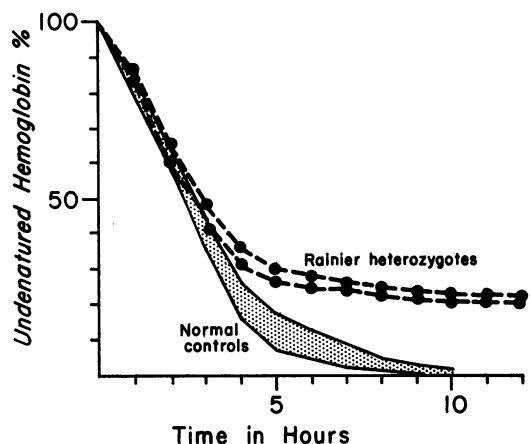

FIGURE 4 Comparison of hemoglobin heat stability at 60°C in 10 normal controls and unfractionated hemolysates from two hemoglobin Rainier heterozygotes.

CM-Sephadex chromatography (Fig. 3). Starch-block and starch-gel electrophoresis of unfractionated hemolysates, using Tris-ethylenediaminetetraacetate (EDTA)-borate (TEB), Tris-HCl, or phosphate buffer systems over a wide pH range, failed to separate hemoglobin Rainier from hemoglobin A. Comparison of isolated fractions on starch gel (TEB buffer at pH 8.6) indicated slightly slower anodic mobility of hemoglobin Rainier.

Hemolysates prepared from six individuals with hemoglobin Rainier had normal amounts of hemoglobin A<sub>2</sub> (2.6–3.2%). The amount of alkali-resistant hemoglobin ranged from 12.6 to 16.8%. From the knowledge of alkali denaturation kinetics of isolated hemoglobin Rainier and the finding that only the  $\beta$ -chains of hemoglobin Rainier resist denaturation by alkali,<sup>1</sup> it was calculated that the amount of hemoglobin Rainier in heterozygotes was 25–34%. These calculations are in agreement with the proportions of hemoglobin Rainier and hemoglobin A<sub>2</sub> quantitated in four individuals by CM-Sephadex chromatography. Heat denaturation of unfractionated hemolysates showed increased hemoglobin stability (Fig. 4). Oxygenated solutions of unfractionated hemolysates had normal visible spectra. The acid and alkali methemoglobin derivatives of isolated hemoglobin Rainier had maximum and minimum absorptions at the same wavelengths as the derivatives of methemoglobin A (Fig. 5). However, the absorption spectrum of acid and alkali methemoglobin Rainier at wave lengths 560–700 and 540–700 m $\mu$ , respectively, had slightly greater optical densities than those of the same derivatives of hemoglobin A.

*Oxygen equilibria of whole blood.* The mean oxygen equilibrium curve of seven subjects (by the mixing technique)

<sup>1</sup>Stamatoyannopoulos, G., and A. Yoshida. Unpublished observations.

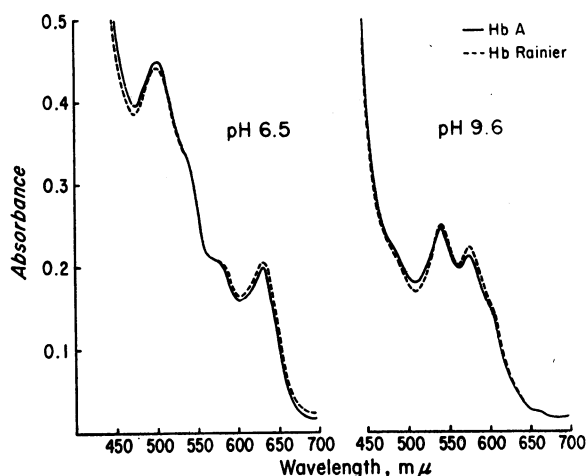

FIGURE 5 Comparison of visible absorption spectra of acidic and alkaline derivatives of methemoglobin Rainier and methemoglobin A.

whose blood contained hemoglobin Rainier at a temperature of 38°C and pH 7.40 is depicted in Fig. 6. Also shown is the mean oxygen equilibrium curve of normal human adult blood at the same temperature and

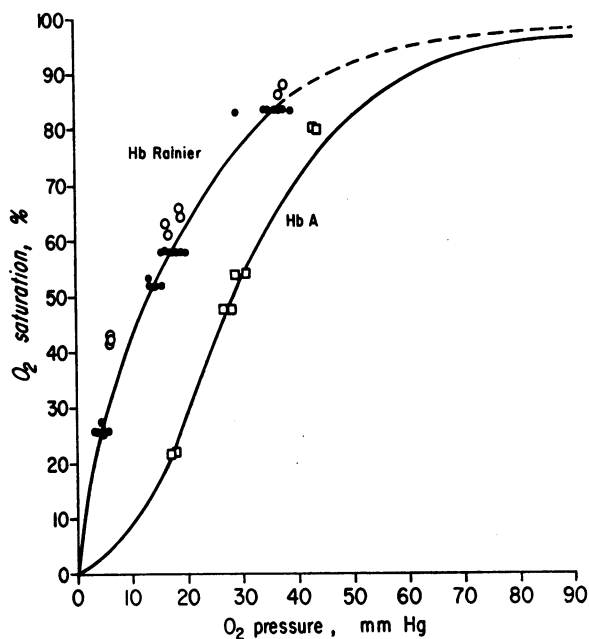

FIGURE 6 Oxygen equilibrium curve of whole blood from seven subjects with hemoglobin Rainier compared with that of normal adult human blood at 38°C and pH 7.40. The hemoglobin Rainier curve is the average determined by the mixing technique (●). The Hb A curve is from Severinghaus (32) with points obtained in this laboratory by the mixing technique superimposed. The open circles (○) for hemoglobin Rainier were obtained manometrically.

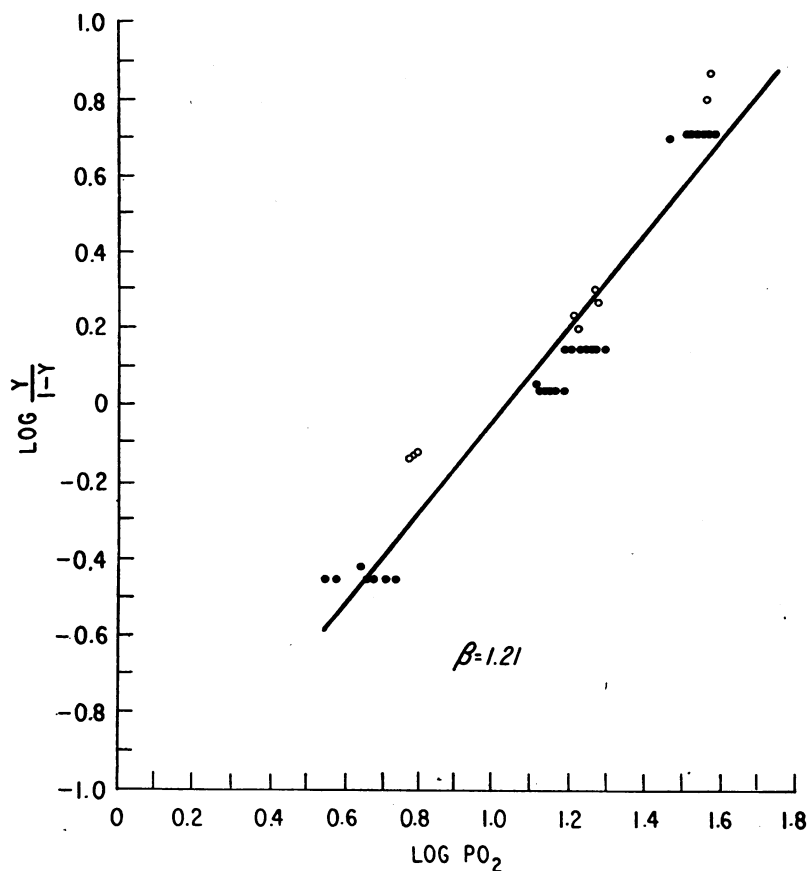

FIGURE 7 Hill plot of points shown in Fig. 6 determined by both the manometric (○) and mixing (●) techniques.

pH (32). There was satisfactory agreement between the oxygen equilibrium curves of the abnormal blood determined by the manometric and mixing methods. The oxygen affinity was extremely high, the mean  $P_{O_2}$  at 50% saturation being 12.8 mm Hg with the mixing technique. The curves were hyperbolic in shape. The value of  $n$  in Hill's equation was determined by the method of least squares. Hill's equation is:  $\log (Y/1 - Y) = n \log P_{O_2} + \log K$ , where  $Y$  is the degree of oxygenation,  $P_{O_2}$  is oxygen pressure, and  $n$  and  $K$  are constants. The most probable value for whole blood containing hemoglobin Rainier is 1.21 (Fig. 7) whereas that in normal adult human blood is 2.66. Methemoglobin was absent from the blood samples after tonometry, and hemolysis was negligible.

The mean value of the Bohr effect factor, defined as  $\Delta \log P_{O_2} / \Delta \text{pH}$ , was  $-0.42$  (SEM  $\pm 0.07$ ,  $n = 10$ ). This is not significantly different from the normal value for adult human blood (32). The oxygen capacity of blood from the various subjects is shown in Table I. The regression equation relating pH of red cell hemolysates to plasma pH is shown in Table II, together with the

equation for normal human adult blood as determined in this laboratory. The pH of red cells at a plasma pH of 7.40 is 7.17 for the abnormal blood and 7.20 for normal human blood. Thus, an altered intracellular pH does not account for the increased oxygen affinity of cells containing hemoglobin Rainier; in fact, the slightly lower than normal pH observed would tend to decrease the oxygen affinity in comparison to normal human blood.

*Oxygen equilibria of hemoglobin solutions.* The average oxygen equilibrium curve of unfractionated hemolysates from two subjects with hemoglobin Rainier is shown in Fig. 8, together with a curve for normal hemoglobin A. Approximately 6% of the hemoglobin was present as methemoglobin after tonometry. Absorption spectra in the ultraviolet and visible regions showed no evidence of hemoglobin denaturation after tonometry. As with whole blood, the oxygen equilibrium curve of hemolysates containing 30% hemoglobin Rainier was shifted significantly to the left of that of hemolysates obtained from normal subjects. The value of Hill's  $n$  was 1.08, while that for the hemolysate of normal blood was 2.94.

TABLE II  
Regression Equations Relating the pH of Plasma and pH of Red Blood Cell Hemolysates of Blood from Subject II-2 and Normal Adult Humans

Subject	Equation	SD	Correlation coefficient	Erythrocyte pH at a plasma pH of 7.40
II-2	$pH_{RBC} = 0.821 pH_{blood} + 1.091$	$\pm 0.021$	0.984	7.17
Normal adult humans	$pH_{RBC} = 0.814 pH_{blood} + 1.176$	$\pm 0.013$	0.995	7.20

Since a microtechnique for the determinations of oxygen equilibria was not available, chromatographic separations of hemoglobins Rainier and A using 10 ml of a solution containing 10 g of hemoglobin/100 ml were attempted. The chromatographic procedure was prolonged and although the hemoglobin Rainier fraction contained practically no hemoglobin A, there was 5-6% hemoglobin Rainier in the hemoglobin A fraction. After concentration and dialysis the methemoglobin contents of hemoglobins A and Rainier were 17 and 29% respectively. After tonometry they ranged from 19.8 to 24.1% for the hemoglobin A and from 31.9 to 33.7% for the hemoglobin Rainier. These values for the hemoglobin Rainier are not corrected for the relatively higher absorption of methemoglobin Rainier at 630  $m\mu$ .

In the presence of these contaminants, the  $P_{50}$  of the hemoglobin A fraction was 12.5 mm Hg, and of the Rainier fraction, 2 mm Hg. The determinations were at 33°C and the pH was 6.29 and 6.26, respectively. Correction factors for calculating the shift of the oxygen equilibrium curves due to the presence of methemoglobin and hemoglobin Rainier in the A fraction and the presence of methemoglobin in the hemoglobin Rainier fraction are not available. It is known that the presence of methemoglobin in ox and human hemoglobin solutions and in dog blood shifts the curve to the left (33). The wide separation in values of  $P_{50}$  of the two fractions and the relatively close values of methemoglobin make it likely that the abnormal hemoglobin is responsible for the shift to the left of the oxygen equilibrium curves seen in both whole blood and unfractionated hemolysates containing hemoglobin Rainier.

A significant Bohr effect factor ( $-0.28$ ) was measured in the isolated hemoglobin A. It was not possible to determine the factor in isolated hemoglobin Rainier because the extremely low values of oxygen tension were almost within the limits of error of the meter.

Although methodologic limitations prevented direct measurements of oxygen equilibria and calculation of Hill's  $n$  for the isolated hemoglobin Rainier fraction, the effect of the presence of hemoglobin Rainier in decreasing heme-heme interaction in whole blood or unfractionated hemolysates merits comment. Even if the value of Hill's  $n$  in isolated hemoglobin Rainier were 1.0,

the observed value,  $n = 1.21$  for whole blood or hemolysates, is well below that expected for hemoglobin mixtures containing 30% hemoglobin Rainier and 70% hemoglobin A. However, similarly decreased  $n$  values, not corresponding to the sum of  $n$ 's in the isolated hemoglobin components, have been observed in hemolysates containing 38% hemoglobin Yakima ( $n = 1.1$ ) (16), 45% hemoglobin Kempsey ( $n = 1.1$ ) (17), and 50% hemoglobin Kansas ( $n = 1.1$ ) (34).

*Regulation of erythropoiesis.* Studies characterizing erythropoiesis in the proposita with hemoglobin Rainier are summarized in Table III. The red cell mass was 34.4 cc/kg body weight, above the upper limit of normal by the method employed. The plasma iron turnover was 0.92 mg/100 ml blood per day (normal:  $0.70 \pm 0.15$ ).

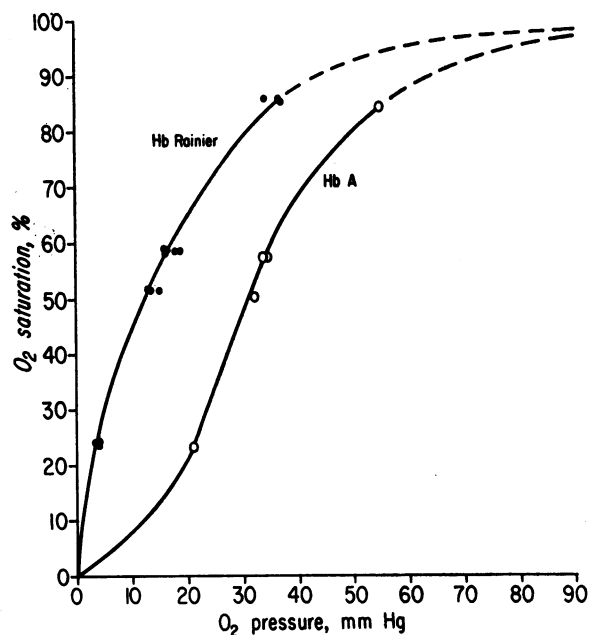

FIGURE 8 Oxygen equilibrium curves of unfractionated hemoglobin solutions from blood containing hemoglobin Rainier and from normal human adult blood dialyzed against 0.05 M phosphate buffer. Hemoglobin concentration was approximately 4 g/100 ml, carbon dioxide tension was 40 mm Hg, pH 6.27-6.34, and the determinations were made at 33°C.

TABLE III  
Ferrokinetic and Erythropoietin Data

Hb	Subject	Age	Sex	Hemato- crit	Reticulo- cytes	Red cell mass	Serum iron	T <sub>‡</sub> plasma disappear- ance	PIT <sub>‡</sub>	EIT <sub>‡</sub>	Urinary erythro- poietin
							TIBC*	min			
					%	cc/kg					Std. B U/day
Rainier	C. B.	47	F	52.0	1.0	34.4	79/415	45.5	0.92	0.86	3.0
				43.4	2.5§	—	—	—	—	—	10.0
Yakima	L. J.	43	M	47.5	1.5	—	—	—	—	—	9.2
	K. J.	15	F	54.0	1.2	35.8	123/361	73.0	0.82	0.74	2.4
				45.5	2.2§	—	—	—	—	—	9.1

\* TIBC = total iron-binding capacity.

† Plasma iron turnover (PIT) and erythrocyte iron turnover (EIT) as mg of iron/100 ml whole blood per day.

§ Peak observed.

Utilization of iron tracer was 94% at 14 days and the calculated erythrocyte iron turnover 0.86 mg (average normal: 0.56 mg). The baseline corrected reticulocyte count was normal (1.0%) as was the average erythropoietin excretion measured over a 4 day period before the exchange phlebotomy. Lowering of the hematocrit in this patient resulted in an increase in the average excretion of erythropoietin from 3.0 to 10.0 Standard B U/day. The rise in urinary erythropoietin was accompanied by an increase in reticulocyte production.

Results of the studies carried out on the daughter of the propositus with hemoglobin Yakima were similar to those seen with hemoglobin Rainier (Table III). Baseline erythropoietin excretion averaged 2.4 Standard B U/day and rose to a mean value of 9.1 U over the 4 days after phlebotomy, with peak excretion of 12.9 U occurring on day 3. The relationships of the daily hematocrits, corrected reticulocyte counts, and urinary erythropoietin are shown for both patients in Fig. 9.

While at a hematocrit of 47.5, erythropoietin excretion in the propositus of the family with hemoglobin Yakima averaged 9.2 U/day.

The slopes of the lines relating the log of erythropoietin excretion and hematocrit in the two individuals subjected to phlebotomy were  $-0.0608$  and  $-0.0681$  for hemoglobins Rainier and Yakima, respectively. The erythropoietin/hematocrit relationship for each individual studied is shown in Fig. 10. The slopes of response are similar to, but exceed the mean slope ( $\beta = -0.0303$ ) derived from 12 normal subjects (9).

## DISCUSSION

Hemoglobin Rainier is yet another example of an abnormal hemoglobin having increased oxygen affinity and associated with erythrocytosis in affected family members. The oxygen equilibrium curve of whole blood con-

taining hemoglobin Rainier is indistinguishable from that of hemoglobin Yakima, and the oxygen affinity of unfractionated hemolysates of hemoglobins Yakima, Kempsey, and Rainier, when corrected for temperature differences, are also very similar. With all three of these hemoglobins there are impaired heme-heme interactions (low Hill's  $n$ ), a hyperbolic oxygen equilibrium curve, and presence of a Bohr effect.

Individuals with erythrocytosis associated with abnormal hemoglobins such as Rainier and Yakima provide a unique opportunity to study some of the factors regulating erythropoiesis. With the exception of polycythemia vera and certain neoplastic states in which erythropoiesis is not physiologically controlled, erythrocytosis appears explainable on the basis of alterations in oxygen delivery to those critical intrarenal sites which govern the production of erythropoietin. This delivery can be affected by the amount of oxygen available to hemoglobin (high altitude dwellers; pulmonary disease) or by changes in the level of circulating hemoglobin. It has been postulated that hemoglobins having high oxygen affinity result in erythrocytosis by interrupting oxygen delivery and producing "tissue hypoxia" although arterial blood gas studies and cardiac hemodynamics have been normal when tested (13, 16). For this postulate to be correct, the site within the kidney responsible for regulating erythropoietin production must be sensitive to oxygen tensions in the postarterial tree-in capillary or venous blood. This conclusion is also suggested by the fact that anemia leads to increased erythropoietin production but does not result in arterial hypoxemia.

Normally there is a remarkable constancy of mixed venous oxygen tension in different mammalian species having either similar or widely varying body weight and in sheep with different hemoglobin oxygen affinities (35, 36). It would appear that oxygen capacity and



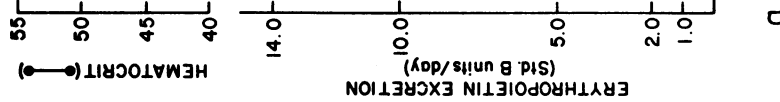
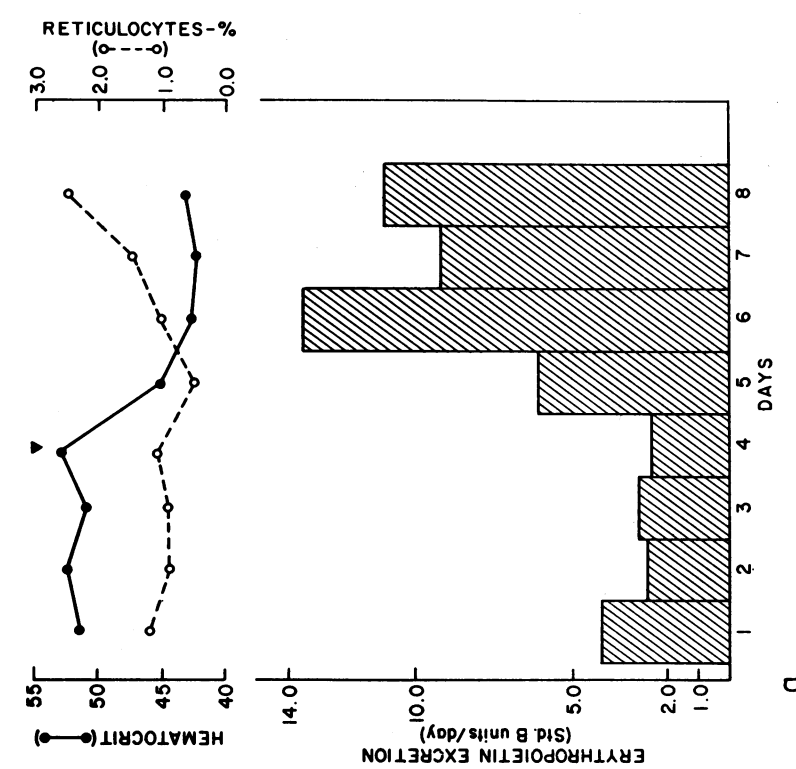
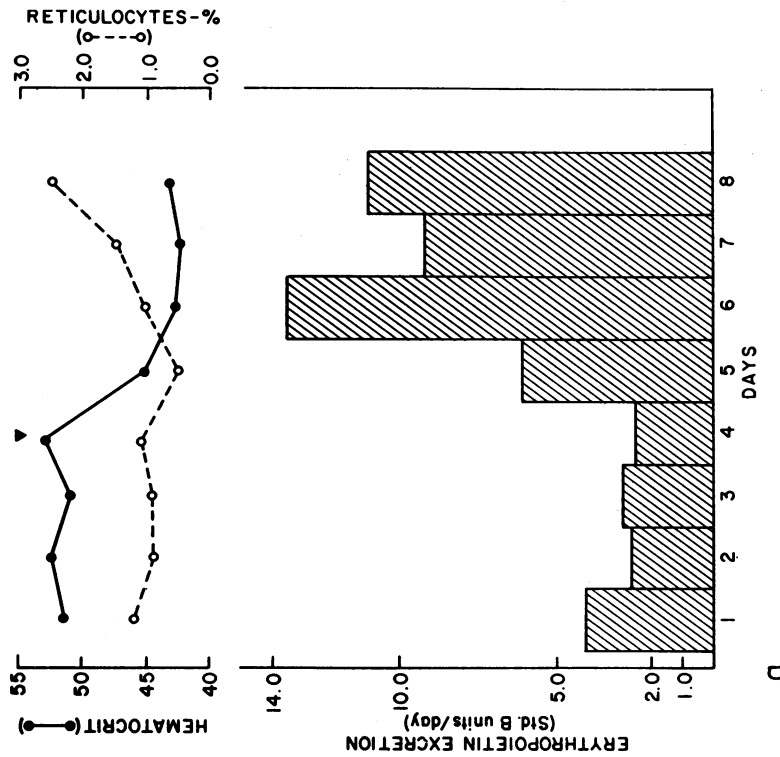
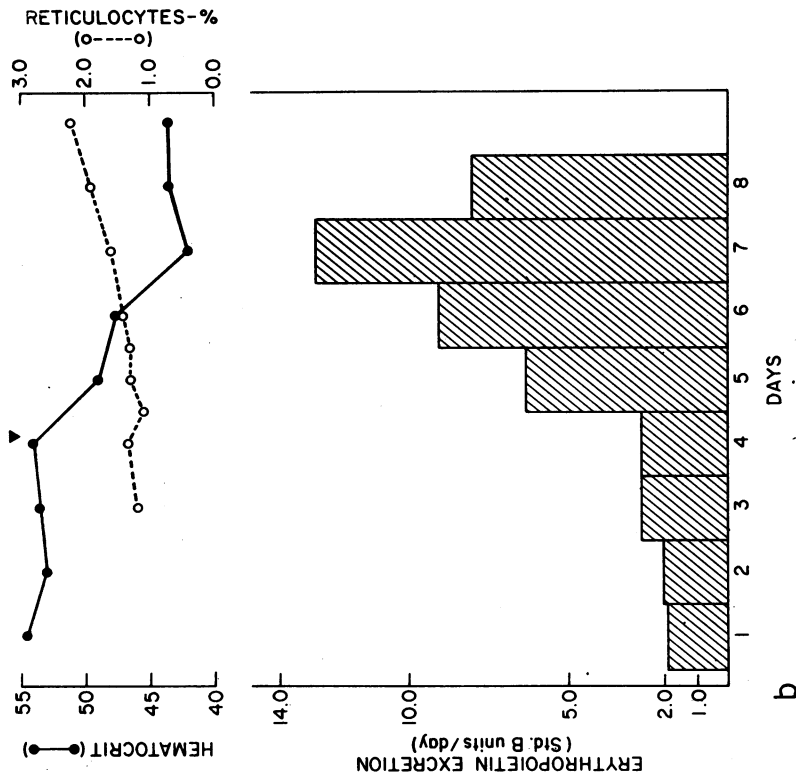

FIGURE 9 The relationship of daily hematocrit, corrected reticulocyte count, and erythropoietin excretion before and after a partial exchange phlebotomy (▼) in subjects with hemoglobins Rainier (a) and Yakima (b).

affinity are matched to provide an appropriate delivery of oxygen at the usual tissue oxygen tensions. In all of these species, this matching may be mediated by the same mechanism and possibly the same oxygen tension within the renal sensor tissue thus explaining the similar values of mixed venous oxygen tension which have been observed.

Consistent with these findings in animals is the demonstration that the degree of erythrocytosis in patients with hemoglobin Yakima compensates sufficiently to allow an almost normal mixed venous oxygen tension (16). Thus it is likely that a virtually normal oxygen tension is also attained in the renal sensor tissue. If this is the case, one might expect erythropoietin production to be normal or near normal in patients such as these who have attained an elevated but stable hematocrit. Also, one would expect that at a normal hematocrit the renal tissue in these patients would be hypoxic because of a decreased venous or capillary oxygen tension, and erythropoietin production would be stimulated. The results in the subjects reported here are in conformity with these predictions.

Two of the subjects studied had a rate of erythropoietin excretion very similar to that seen in normal man despite hematocrits of 52.0 and 54.0. When the red cell mass was experimentally lowered to normal, however, urinary excretion of erythropoietin increased markedly to 9.1 and 10.0 Standard B U/day. Similar levels are seen in average normal controls only when anemic (hematocrits 32.0–33.0) (9). Furthermore, at a hematocrit of 47.5, the propositus with hemoglobin Yakima excreted 9.2 Standard B U/day, more than two standard deviations above the mean daily erythropoietin excretion in normals ( $4.1 \pm 1.9$  U/day in this laboratory). In the two phlebotomized subjects, the increased secretion of erythropoietin was associated with an increase in the reticulocyte index, indicating an appropriate marrow response to the hypoxic stimulus.

The relationship between erythropoietin excretion and hematocrit in these two subjects differs from that in normal man. Not only is the response curve shifted to the right of normal but the slopes of response are greater than the mean normal slope, a relationship previously described in other states of compensated erythropoiesis (37).

Hemoglobin Rainier, being a  $\beta$ -chain variant, should be found only in very small amounts in the blood of fetuses born to afflicted mothers. If the whole blood oxygen dissociation curve of such fetuses is that expected for fetal hemoglobin and is half-saturated at an oxygen tension of 20 mm Hg (38), then the situation pertaining to hemoglobin Rainier represents the first in any species in which fetal oxygen affinity is less than that of the mother. In two other families with abnormal hemo-

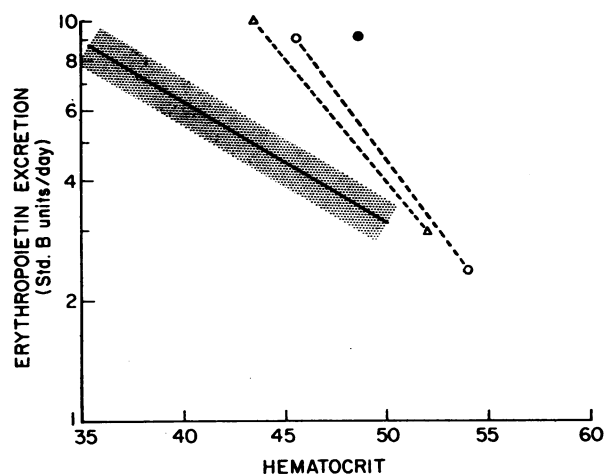

FIGURE 10 The hematocrit/log erythropoietin response curves in Hb Rainier ( $\Delta$ ) and Hb Yakima ( $\circ$ ,  $\bullet$ ). Shaded line indicates the response curve seen in normal subjects.

globins of high oxygen affinity, Chesapeake (13) and Zurich (39), the probable fetal blood oxygen affinity is slightly greater than that of maternal blood. With all three of these abnormal hemoglobins, however, carriers of the trait have reproduced apparently normally (13, 39) producing both normals and heterozygotes. It is clear some other mechanisms must compensate at least partially for this situation in hemoglobin Rainier mothers to ensure adequate fetal oxygenation, since only one spontaneous abortion is recorded for a total of 17 pregnancies in affected members. Such compensatory mechanisms might involve placental and umbilical blood flow, oxygen carrying capacity, size of the placenta, or its geometry (40).

#### ACKNOWLEDGMENTS

We are indebted to the American Red Cross for providing 5% albumin solution used in the phlebotomy studies and the National Research Council of England which generously provided the erythropoietin Standard B. We are deeply grateful to Doctors Robert Koler and Edwin Osgood of the University of Oregon Medical School who made possible the studies on the family with hemoglobin Yakima.

This investigation was supported in part by U. S. Public Health Service Research Grant Nos. 5-R01-HE-06242 and GM-15253 and Fellowship Grant No. 5-F2-AM29, 875-02. A portion of this work was conducted through the Clinical Research Center Facility of the University of Washington (supported by NIH Grant FR-37).

#### REFERENCES

- Gordon, A. S., G. W. Cooper, and E. D. Zanjani. 1967. The kidney and erythropoiesis. *Seminars Hematol.* 4: 337.
- Gordon, A. S., J. Winkert, B. S. Dornfest, and C. D. Siegel. 1959. Studies on the actions and properties of the circulating erythropoietic stimulating factor. *Ann. N. Y. Acad. Sci.* 77: 650.

3. Alpen, E. L., D. Cranmore, and M. E. Johnston. 1962. Early observation on the effects of blood loss. In *Erythropoiesis*. L. O. Jacobson, editor. Grune and Stratton Inc., New York. 184.
4. Erslev, A. J. 1959. Erythropoietic factor in the control of red cell production. *Ann. N. Y. Acad. Sci.* 77: 627.
5. Filmanowicz, E. and C. W. Gurney. 1961. Studies on erythropoiesis. XVI. Response to a single dose of erythropoietin in polycythemic mouse. *J. Lab. Clin. Med.* 57: 65.
6. Adamson, J. W., R. Alexanian, C. Martinez, and C. A. Finch. 1966. Erythropoietin excretion in normal man. *Blood*. 28: 354.
7. Alexanian, R. 1966. Urinary excretion of erythropoietin in normal men and women. *Blood*. 28: 344.
8. Van Dyke, D., M. L. Nohr, and J. H. Lawrence. 1966. Erythropoietin in urine of normal and erythropoietically abnormal human beings. *Blood*. 28: 535.
9. Adamson, J. W. 1968. The erythropoietin/hematocrit relationship in normal and polycythemic man: implications of marrow regulation. *Blood*. 32: 597.
10. Linman, J. W., and F. H. Bethell. 1957. The plasma erythropoietic-stimulating factor in man. Observations on patients with polycythemia vera and secondary polycythemia. *J. Lab Clin. Med.* 49: 113.
11. Contopoulos, A. N., R. McCombs, J. H. Lawrence, and M. E. Simpson. 1957. Erythropoietic activity in the plasma of patients with polycythemia vera and secondary polycythemia. *Blood*. 12: 614.
12. Freedman, B. J. and D. G. Penington. 1963. Erythrocytosis in emphysema. *Brit. J. Haematol.* 9: 425.
13. Charache, S., D. J. Weatherall, and J. B. Clegg. 1966. Polycythemia associated with a hemoglobinopathy. *J. Clin. Invest.* 45: 813.
14. Rucknagel, D. L., K. P. Glynn, and J. R. Smith. 1967. Hemoglobin Ypsi, characterized by increased oxygen affinity, abnormal polymerization and erythremia. *Clin. Res.* 15: 270.
15. Jones, R. T., E. E. Osgood, B. Brimhall, and R. D. Koler. 1967. Hemoglobin Yakima. I. Clinical and biochemical studies. *J. Clin. Invest.* 46: 1840.
16. Novy, M. J., M. J. Edwards, and J. Metcalfe. 1967. Hemoglobin Yakima. II. High blood oxygen affinity associated with compensatory erythrocytosis and normal hemodynamics. *J. Clin. Invest.* 46: 1848.
17. Reed, C. S., R. Hampson, S. Gordon, R. T. Jones, M. J. Novy, B. Brimhall, M. J. Edwards, and R. D. Koler. 1968. Erythrocytosis secondary to increased oxygen affinity of a mutant hemoglobin, hemoglobin Kempsey. *Blood* 31: 623.
18. Hamilton, H. B., I. Iuchi, T. Miyaji, and S. Shibata. 1969. Hemoglobin Hiroshima ( $\beta^{148}$  histidine  $\rightarrow$  aspartic acid): a newly identified fast moving beta chain variant associated with increased oxygen affinity and compensatory erythremia. *J. Clin. Invest.* 48: 525.
19. Stamatoyannopoulos, G., A. Yoshida, J. Adamson, and S. Heinenberg. 1968. Hemoglobin Rainier ( $\beta^{146}$  tyrosine  $\rightarrow$  histidine): alkali-resistant hemoglobin with increased oxygen affinity. *Science*. 159: 741.
20. Donohue, D. M., A. G. Motulsky, E. R. Giblett, G. Pirzio-Biroli, V. Viranuvatti, and C. A. Finch. 1955. The use of chromium as a red cell tag. *Brit. J. Haematol.* 1: 249.
21. Drabkin, D. L. 1946. Spectrophotometric studies. XIV. The crystallographic and optical properties of the hemoglobin of man in comparison with those of other species. *J. Biol. Chem.* 164: 703.
22. Robinson, A. R., M. Robson, A. P. Harrison, and W. W. Zuelzer. 1957. A new technique for differentiation of hemoglobin. *J. Lab. Clin. Med.* 50: 745.
23. Jonxis, J. H. P., and H. K. A. Visser. 1956. Determination of low percentages of fetal hemoglobin in blood of normal children. *Amer. J. Dis. Child.* 92: 588.
24. Betke, K., H. R. Marti, and I. Schlicht. 1959. Estimation of small percentages of foetal haemoglobin. *Nature (London)*. 184: 1877.
25. Scholander, P. F. 1947. Analyzer for accurate estimation of respiratory gases in one-half cubic centimeter samples. *J. Biol. Chem.* 167: 235.
26. Edwards, M. J., and R. J. Martin. 1966. Mixing technique for the oxygen-hemoglobin equilibrium and Bohr effect. *J. Appl. Physiol.* 21: 1898.
27. Parer, J. T., A. S. Hoversland, and J. Metcalfe. 1967. Some respiratory characteristics of the blood of the adult and young African pygmy goat. *J. Appl. Physiol.* 22: 756.
28. Hilpert, P., R. G. Fleischmann, D. Kempe, and H. Bartels. 1963. The Bohr effect related to blood and erythrocyte pH. *Amer. J. Physiol.* 205: 337.
29. Evelyn, K. A., and H. T. Malloy. 1938. Microdetermination of oxyhemoglobin, methemoglobin and sulfhemoglobin in a single sample of blood. *J. Biol. Chem.* 126: 655.
30. Giblett, E. R., D. H. Coleman, G. Pirzio-Biroli, D. M. Donohue, A. G. Motulsky, and C. A. Finch. 1956. Erythrokinetics. Quantitative measurements of red cell production and destruction in normal subjects and patients with anemia. *Blood*. 11: 291.
31. Brecher, G., and M. Schneiderman. 1950. Evaluation of electronic red blood cell counter. *Amer. J. Clin. Pathol.* 26: 1439.
32. Severinghaus, J. W. 1966. Blood gas calculator. *J. Appl. Physiol.* 21: 1108.
33. Darling, R. C., and F. J. W. Roughton. 1942. The effect of methemoglobin on the equilibrium between oxygen and hemoglobin. *Amer. J. Physiol.* 137: 56.
34. Reissmann, K. R., W. E. Ruth, and T. Nomura. 1961. A human hemoglobin with lowered oxygen affinity and impaired heme-heme interactions. *J. Clin. Invest.* 40: 1826.
35. Parer, J. T., W. D. Jones, and J. Metcalfe. 1966. A quantitative comparison of oxygen transport in sheep and human subjects. *Resp. Physiol.* 2: 196.
36. Parer, J. T., and J. Metcalfe. 1967. Oxygen transport by blood in relation to body size. *Nature (London)*. 215: 653.
37. Adamson, J. W. and C. A. Finch. 1966. Mechanisms of erythroid marrow activation. *Trans. Ass. Amer. Physicians Philadelphia*. 79: 419.
38. Hellegers, A. E., and J. J. P. Schreuder. 1961. Nomograms and empirical equations relating oxygen tension, percentage saturation and pH in maternal and fetal blood. *Amer. J. Obstet. Gynecol.* 81: 377.
39. Moore, W. M. O., F. C. Battaglia, and A. E. Hellegers. 1967. Whole blood oxygen affinities of women with various hemoglobinopathies. *Amer. J. Obstet. Gynecol.* 97: 63.
40. Metcalfe, J., H. Bartels, and W. Moll. 1967. Gas exchange in the pregnant uterus. *Physiol. Rev.* 47: 782.