

# Gene Therapy for Vascular Diseases

**Kenneth K. Wu, MD**  
**Pierre Zoldhelyi, MD**  
**James T. Willerson, MD**  
**Xiao-Ming Xu, PhD**  
**David S. Loose-Mitchell, PhD**  
**Lee-Ho Wang, PhD**

*Gene transfer by virus- and liposome-mediated vectors has potential for treating genetic diseases, cancer, and cardiovascular diseases. In this article, we discuss the general principle and techniques for gene transfer and the specific issues facing therapy for vascular diseases. We also propose a strategy for using virus-mediated gene transfer to restore the vasoprotective function of the vascular wall, thereby preventing vascular thrombosis. Experimental data from ongoing work in our laboratories are presented to illustrate the importance of this approach in vascular gene transfer therapy. (Texas Heart Institute Journal 1994;21:98-103)*

**Issue editors:**

Ward Casscells, MD  
Robert Roberts, MD  
Jeffrey A. Towbin, MD

**Key words:** Gene therapy;  
prostacyclin; prostaglandin-  
endoperoxide synthase;  
prostaglandin H synthase;  
thrombosis

**From:** The Vascular Biology Research Center, Department of Internal Medicine, Divisions of Hematology (Drs. Wu, Zoldhelyi, Xu, and Wang) and Cardiology (Dr. Willerson), and Department of Pharmacology (Dr. Loose-Mitchell), The University of Texas Medical School at Houston; and the Department of Cardiology Research (Dr. Willerson), Texas Heart Institute; Houston, Texas.

Supported in part by grant HL-35387 to Dr. Wu, grants HL-50179 and HL-17669 to Dr. Willerson, and program project grant NS-23327 from the National Institutes of Health to Drs. Wu, Zoldhelyi, Xu, Loose-Mitchell, and Wang.

**Address for reprints:**

Dr. Kenneth K. Wu,  
Division of Hematology,  
MSB 5.016,  
The University of Texas  
Medical School at Houston,  
6431 Fannin Street,  
Houston, TX 77030

**T**he blood vessel is lined with a monolayer of endothelial cells, which play a crucial role in maintaining blood fluidity and vascular patency.<sup>1</sup> Endothelial cells generate a number of powerful molecules that protect blood vessels from injury and major disease processes, such as thrombosis and atherosclerosis. At least 7 classes of molecules have been identified: prostacyclin (PGI<sub>2</sub>); nitric oxide (NO); ecto-ADPase; thrombomodulin; heparin-like molecules; tissue factor pathway inhibitor (TFPI); and tissue plasminogen activator (tPA). Prostacyclin is synthesized via a series of enzymes and, once released extracellularly, has a short half-life.<sup>2,3</sup> It is a potent inhibitor of platelet activation, secretion, and aggregation and is also a potent vasodilator. Synthesis of NO is catalyzed by NO synthase.<sup>4</sup> Nitric oxide is released extracellularly to maintain vasorelaxation. Moreover, it inhibits platelet adhesion and acts synergistically with PGI<sub>2</sub> in suppressing platelet aggregation.<sup>5,6</sup> These 2 compounds, hence, play a major role in maintaining vascular patency and blood fluidity. Ecto-ADPase, on the other hand, is present on the endothelial cell surface, which degrades adenosine diphosphate (ADP) released from activated platelets. Thrombomodulin and heparin are also expressed constitutively on the endothelial cell surface. These 2 membrane molecules serve as co-factors for naturally occurring anticoagulants. Thrombin, through its binding to the protein thrombomodulin, becomes active in converting protein C into an activated form that, in the presence of protein S, degrades factors Va and VIIIa, thereby curtailing the coagulation reaction and fibrin formation. Heparin-like molecules function as an antithrombin III co-factor for inactivation of thrombin, factor Xa, IXa, and other activated coagulation factors. TFPI inhibits the factor VIIa-mediated activation of factor X. These 3 factors (thrombomodulin, heparin-like molecules, and tissue factor pathway inhibitor) are molecules naturally endowed for controlling thrombin generation and fibrin formation. The final product on the list is tPA, which catalyzes the formation of plasmin, thereby digesting fibrin clots. All 7 defense molecules are constitutively produced for carrying out their physiologic functions. A loss of any of these defense molecules, due to endothelial cell damage or depletion, is considered to have a detrimental effect on vascular integrity. The vasoprotective properties of the damaged endothelium become substantially compromised, which permits platelet adhesion and aggregation, and fibrin formation, at the damaged vascular wall. Moreover, endothelial cell perturbation may result in the expression of procoagulant and prothrombotic molecules. Impairment in endothelial cell function contributes significantly to such vascular lesions as atherosclerosis, thrombosis, and intimal hyperplasia.

Several of these active molecules have been purified or synthesized and administered systemically for treatment of arterial thrombotic disorders. For example, the infusion of tissue plasminogen activator has reduced significantly the morbidity and mortality of coronary heart disease.<sup>7-9</sup> Stable prostacyclin analogs, e.g., iloprost, improve circulation and reduce ischemic changes due to peripheral vas-

cular disease in lower extremities.<sup>10</sup> However, adverse effects can ensue when large doses of these compounds must be administered systemically to achieve therapeutic results. Furthermore, bioavailability is limited when these compounds are administered systemically, due to an inherent short half-life of the compounds, as in the case of PGI<sub>2</sub> and NO, or due to neutralization by a specific natural inhibitor, such as neutralization of tPA by plasminogen activator inhibitor-1 (PAI-1). Another important constraint is that most of the defense molecules act locally as autacoids (PGI<sub>2</sub> and NO), or selectively at fibrin-generating sites (tPA)—and systemic administration often does not produce an adequate local concentration of these compounds. A more physiologic approach is to deliver the vasoprotective molecules to the sites of vascular injury and lesions. In this context, gene transfer therapy is an important recent development.

### General Aspects of Gene Transfer Therapy

Recent studies indicate that it is feasible to transfer reporter genes such as  $\beta$ -galactosidase and luciferase to the vascular wall by retrovirus-, adenovirus- and liposome-mediated gene transfer. Each type of vector has its advantages and disadvantages. Moreover, although techniques for delivering and/or targeting the desired gene to the vascular lesion or the potential vascular-injury site are being developed rapidly, their potentials for use in vascular gene therapy are not yet fully realized. In this paper, we review vectors that are suitable for vascular gene transfer and the emerging general techniques and concepts for gene delivery and targeting.

*Vectors for Vascular Gene Transfer.* Transfer of a desired gene into the vascular tissue may be achieved by using replication-defective viral vectors or liposomes. Several types of viruses have been used, but retroviruses and adenoviruses are by far the most commonly used vectors. The general technique for using replication-defective retroviruses in gene transfer has been described in a review article.<sup>11</sup> The retroviral genome is rather simple when compared to those of other viruses. It contains long terminal repeats (LTR) at its 5' and 3' flanking regions. The 5'-LTR is a potent promoter. Downstream from the 5' LTR is a segment that transcribes a signal essential for proper assembly of the retroviral envelope. To construct a retroviral vector for gene transfer, the 3 retroviral structural genes are removed, and inserted in their place is a reporter gene such as the *Escherichia coli lacZ* ( $\beta$ -galactosidase,  $\beta$ -gal) gene and the neomycin-resistant (Neo<sup>R</sup>) gene. For transfer of a desired gene, the *lacZ* cDNA is replaced with the cDNA of the desired gene. To produce a large quantity of retroviral vectors carrying the gene, a specially engineered packaging cell line

is used to generate the viral vectors. The packaging cell line contains all the retroviral genome except for the  $\psi$  segment.<sup>12</sup> When the packaging cells are infected with the viral vector containing the  $\psi$  signal, replication-defective (helper-virus-free) retroviruses containing the reporter gene or the desired gene are produced. These viruses are then used to infect cells or tissues. Because these viral vectors are amphitropic, they interact with cell receptors, enter the cells, and incorporate their DNA contents into the host cell chromosome by a random process. Since they do not contain viral genomes, they are incapable of replication in the host cells. Their 5'-LTR, on the other hand, is an active promoter that serves to drive the transcription of the reporter gene or the inserted gene for transfer, thereby augmenting the synthesis of the gene product. A number of retroviral vectors have been used successfully in transferring genetic materials into vascular wall.<sup>13-17</sup> The advantages of retroviral vectors are their long-term, if not permanent, incorporation into host-cell chromosomes, and the high efficiency of their incorporation into cells in vitro. Disadvantages include: 1) The requirement for in vitro preparation of autologous cells and transfer of the desired gene in vitro prior to administration of the "engineered" cells in vivo. Such procedures are cumbersome, and impractical for future application to clinical therapy. The attempt to transduce vascular cells directly (in vivo) with retroviral vectors is confronted with the problem of achieving a high efficiency.<sup>18</sup> 2) The requirement for cells in active replication. 3) The potential problem of oncogene activation.

Due to these disadvantages, the retroviral vectors are not as likely to be suitable for vasoprotection as for gene therapy of genetic disorders. By contrast, adenoviral vectors have a high affinity for interacting with quiescent and actively replicating cells, and can be used directly for in vivo gene transfer without the initial step of in vitro cell processing. Because the transferred gene is localized extrachromosomally in the nucleus, the gene copies are reduced significantly for each cycle of cell replication. Replication-defective adenoviruses are relatively safe as far as activation of oncogenes is concerned, but may be associated with inflammatory reactions.<sup>19</sup>

Liposome-DNA complexes enter cells through the fusion of liposomes with cell membrane, and the complex then travels intracellularly as endosomes. DNA carrying the desired gene enters the nucleus, and the promoter built into the DNA cassette drives the transcription of the transferred cDNA. A cationic liposome (lipofectin) containing N1-(2,3-dioleoyloxy)propyl-N,N,N-trimethylammonium (DOTMA) has been tried for vascular gene transfer, but direct application of lipofectin-DNA complex to vascular injury sites has not achieved a suitably high degree of

efficiency.<sup>20,21</sup> A recent report indicated an efficient delivery of genes by using liposomes containing a mixture of DOTMA, dioleoyl-phosphatidylethanolamine (DOPE), and CMV-chloramphenicol acetyltransferase (CAT) in a fixed ratio of 8 nmol of liposome to 1  $\mu$ g of DNA.<sup>22</sup> Intravenous injection of the liposome-DNA mixture results in noticeable expression of the CAT reporter gene in endothelium, heart, spleen, bone marrow, and alveolar epithelium.

On the basis of currently available information, it appears that adenoviruses and cationic liposomes are potentially useful vectors for vascular gene transfer. Several promising techniques for delivering and/or targeting the gene(s) to the vascular injury sites are being tested. They are described below.

**Gene Delivery.** The desired gene can be delivered to the vascular sites through perforated balloon catheters<sup>20,21</sup> and by stents coated with endothelial cells into which the gene has been transferred.<sup>23</sup> As mentioned above, direct infusions of retroviruses carrying the gene or liposome-DNA complex by perforated balloon catheters are inefficient in introducing the gene into the vascular cells in vivo.<sup>19,20</sup> Our preliminary data revealed that direct infusion of an adenovirus carrying prostaglandin H synthase-1 (PGHS-1) cDNA was accompanied by increased PGHS-1 transcription and PGI<sub>2</sub> synthesis.<sup>24</sup> Delivery of the desired gene by adenoviruses via perforated balloon catheter or other devices appears to be feasible and is worth pursuing.

**Gene Targeting.** Receptor-directed delivery of a desirable gene to a specific type of cell is an important approach for gene therapy. A prerequisite is the presence of cell-specific or tissue-specific receptors that bind and internalize their ligands. This approach appears to be feasible for targeting genes to hepatocytes. Wu and colleagues have taken advantage of a specific receptor on hepatocytes that recognizes, internalizes, and degrades desialylated proteins.<sup>25-27</sup> They coupled asialoorosomucoid A to poly-L-lysine, which formed a complex with plasmids containing the CAT reporter gene. They were able to target the CAT gene to hepatocytes with considerable expression of CAT protein in vitro and in vivo,<sup>25-27</sup> and they subsequently showed the transfer of albumin cDNA to hepatocytes.<sup>28</sup> This approach was further refined by co-infecting hepatocytes with replication-defective adenoviral vectors,<sup>29</sup> the addition of which increased transduction efficiency by 3 orders of magnitude. These studies presented an exciting potential for transferring genes to hepatocytes. However, receptor-directed gene targeting for vascular gene therapy has not been reported. In order to target genes to vascular lesions, it will be necessary to identify specific receptors expressed on cells in the vascular lesions that are not present on normal endothelial cells.

## Gene Therapy for Vascular Diseases

An important strategic issue regarding gene therapy for vascular diseases is selection of a target gene the enhancement or ablation of which will have therapeutic benefits. This issue remains at an early experimental stage of development. To illustrate the potential use of transferring vascular genes for restoring and enhancing vasoprotective properties, this review describes experiments that are carried out in our laboratories. We have focused our efforts on enhancing the synthesis of PGI<sub>2</sub>, which is one of the most potent inhibitors of platelet activation, secretion, and aggregation—as well as a potent vasodilator. Its production and activity are tightly regulated. Its biosynthesis in vascular endothelial cells is catalyzed sequentially by phospholipase A<sub>2</sub> (PLA<sub>2</sub>), prostaglandin H synthase (PGHS), and prostacyclin synthase (PGIS). PLA<sub>2</sub> catalyzes the liberation of arachidonic acid (AA), which is thought to be the rate-limiting step in the initiation of AA metabolism, while PGHS (which catalyzes the formation of PGH<sub>2</sub>) is considered to be the key step in controlling the total content of PGI<sub>2</sub> synthesis.<sup>30</sup> Prostaglandin H synthase is autoinactivated during catalysis, which severely curtails its catalytic capacity.<sup>31,32</sup> There are 2 isoforms of PGHS. Type 1 PGHS (PGHS-1) is constitutively expressed and probably responsible for physiologic synthesis of PGI<sub>2</sub>, while type 2 PGHS (PGHS-2) is an inducible form and is thought to be involved in inflammation.<sup>33-35</sup> Under physiologic conditions, PGHS (mostly PGHS-1) exists in low quantity. At vascular injury sites or in vascular lesions, its quantity is probably further reduced and the capacity of PGI<sub>2</sub> synthesis is compromised. We postulated that transfer of PGHS-1 cDNA to the vascular cells may increase PGHS-1 expression, and augment PGI<sub>2</sub> production. Our initial experiment to test this hypothesis was to determine whether it was feasible to transfer human PGHS-1 cDNA into a cultured human endothelial cell line (EA.hy 926 cells) by using a retroviral vector (BAG), kindly provided by Connie Cepko at Harvard Medical School. Since this work has been published recently,<sup>36</sup> the experimental procedures and results are given briefly here. The BAG construct is illustrated in Fig. 1. We inserted PGHS-1 cDNA into the BAG vector by replacing the *E. coli lacZ* gene (encoding  $\beta$ -galactosidase) with PGHS-1 cDNA. PGHS-1 cDNA could be inserted in a sense orientation [PGHS(S)] or reverse orientation [PGHS(R)] relative to the BAG 5'-long terminal repeat (LTR) (Fig. 1). Both PGHS(S) and PGHS(R) vectors were isolated and used to transfect a packaging cell line ( $\psi$ CRIP), kindly provided by Richard Mulligan at MIT for production of replication-defective viruses containing PGHS(S) or PGHS(R). We then incubated a human endothelial cell line in medium containing the replication-defective viruses

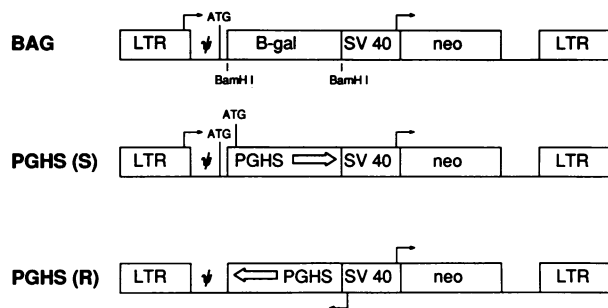

**Fig. 1** Retroviral vectors. The arrows above LTR and SV40 indicate the direction of transcription. The arrows within the PGHS boxes indicate the direction of the coding strand. PGHS(S) denotes the insertion of PGHS-1 in sense orientation relative to the retroviral promoter, and PGHS(R) denotes reverse orientation relative to the retroviral promoter. The cloning sites, BamHI, in the BAG are also shown.

ATG = translation start condon;  $\beta$ -gal =  $\beta$ -galactosidase cDNA; LTR = retroviral long terminal repeat; neo = bacterial neomycin phosphotransferase cDNA; PGHS = human PGHS-1 cDNA;  $\psi$  = viral sequence essential for packaging; SV40 = simian virus 40 promoter and enhancer.

(From: *J Clin Invest* 1993;91:1843-9. By copyright permission of the American Society for Clinical Investigation.)

and a neomycin analog (G-418) for selection of transfected cells. Only transfected cells expressing neomycin phosphotransferase will grow in this medium. Under these experimental conditions, the transfected cells reached confluency in 2 weeks. The PGHS(S) cells expressed a high level of mRNA but did not produce increased PGHS-1 protein because of a shift of the reading frame due to the predominant use of the bacterial *lacZ* start site for transcription. The PGHS(R) cells in which PGHS-1 expression was driven by a SV-40 promoter contained a 20-fold increase in PGHS-1 mRNA and protein levels (Fig. 2). The PGHS(R) cells did not exhibit morphologic changes and retained normal synthetic capacity for tissue-type plasminogen activator and plasminogen activator inhibitor-1. The PGI<sub>2</sub> synthesis in PGHS(R)-transduced cells in response to arachidonic acid and physiologic agonists was markedly increased (Table I). These data provide direct evidence to support the notion that the steady-state level of PGHS-1 is the key determinant of PGI<sub>2</sub> synthetic capacity in vascular endothelial cells; moreover, they give credence to the use of PGHS-1 gene transfer for enhancing vascular antithrombotic activity during injury.

For clinical application, retrovirus-mediated transfer of PGHS-1 will be cumbersome and may be potentially hazardous. Therefore, we tested the feasibility of adenovirus-mediated transfer, using an adenoviral vector provided by Robert Meidell at the University of Texas Southwestern Medical School. The adenoviral vector carrying PGHS-1 cDNA (Ad-PGHS) was efficient in transducing cultured endo-

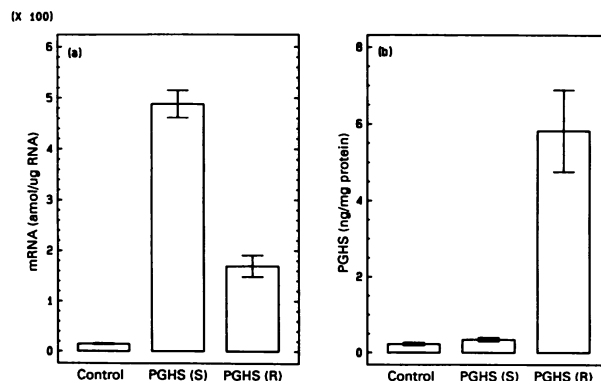

**Fig. 2** Comparison of PGHS-1 mRNA (a) and protein levels (b) in uninfected, PGHS(S), and PGHS(R) endothelial cells. Each bar represents mean value  $\pm$  standard deviation from 3 separate experiments.

PGHS-1 = prostaglandin H synthase-1; PGHS(R) = PGHS-1 cDNA inserted in a reverse orientation; PGHS(S) = PGHS-1 cDNA inserted in a sense orientation.

(From: *J Clin Invest* 1993;91:1843-9. By copyright permission of the American Society for Clinical Investigation.)

thelial cells that expressed a 3-fold increase in PGHS-1 mRNA after 48 hours of adenoviral treatment. The expression of PGHS-1 mRNA in cultured porcine vascular smooth muscle cells was also increased. We then undertook an in vivo study to evaluate the feasibility of transfecting injured vessel directly with Ad-PGHS. Pig carotid arteries were crush-injured, and Ad-PGHS or adenoviral vector (Ad-V) was infused locally to the injured carotid arteries for 30 minutes via a Wolinsky perforated balloon catheter. The carotid arteries were dissected 3 days after virus administration, and their capacity to synthesize PGI<sub>2</sub> was measured. In 4 experiments, PGI<sub>2</sub> production by carotid segments from Ad-PGHS transfected animals in response to arachidonate and ionophore was, respectively, 2.5-fold and 2.9-fold over that of the control animals.

These results confirm that adenoviral vectors can be used for direct delivery of PGHS-1 genes to enhance the synthesis of vasoprotective molecules. To test the efficacy of adenovirus-mediated PGHS-1 transfer in reducing thrombosis and intimal hyperplasia, we infused Ad-PGHS through perforated catheters into pig carotid arteries injured by balloon angioplasty. The antithrombotic efficacy is being evaluated by morphometric measurements and measurement of carotid blood flow by Doppler. We hope that the results derived from the pig angioplasty model will lend support to the further development of transferring PGHS-1 and other vasoprotective genes, individually or in combination, for human gene therapy of vascular diseases such as postangioplasty thrombosis and intimal hyperplasia.

**TABLE I.** Responses of Retrovirus-Infected and Control Cells to Stimulation by Physiologic Agonists

Experiment	6KPGF <sub>1α</sub> Concentration				
	PGHS(R)		PGHS(S)		Control
	PO	P7	PO	P7	
	ng/mL				
Basal	5.75 ± 0.22	4.00 ± 2.60	0.22 ± 0.01	0.16 ± 0.05	0.12 ± 0.01
A23187	46.79 ± 7.03	76.08 ± 0.10	0.57 ± 0.02	0.18 ± 0.01	0.29 ± 0.03
Thrombin	17.89 ± 0.39	15.97 ± 0.67	0.39 ± 0.01	0.37 ± 0.01	0.19 ± 0.10
Arachidonate	26.70 ± 0.75	ND	2.34 ± 0.05	ND	0.32 ± 0.05

The 6KPGF<sub>1α</sub> content (mean ± SD, n=3) in the cultured medium from primary (PO) and passage 7 (P7) PGHS(R) and PGHS(S) cells and from control cells. Cells (2 × 10<sup>6</sup> cells/well) were incubated with 1 mL of medium containing ionophore A23187 (10 μM), thrombin (2 U/mL), and arachidonate (10 μM) at 37 °C for 1 h, and the 6KPGF<sub>1α</sub> content in the cultured medium was assayed.

ND = not done

(From: J Clin Invest 1993;91:1843-9. By copyright permission of the American Society for Clinical Investigation.)

## Comments

Rapid progress has been made in using gene transfer for treating a variety of diseases. For example, for treating genetic diseases, retrovirus and adenovirus-mediated gene transfer has shown promising experimental results in correcting genetic defects of cystic fibrosis,<sup>37</sup> hemophilia B,<sup>38</sup> combined immunodeficiency,<sup>39</sup> and familial hypercholesterolemia.<sup>40,41</sup> These exciting experimental results have led to more extensive testing of the efficacy of gene therapy in correcting genetic defects in patients with the above disorders. Gene therapy for cancer has also developed rapidly from experimental stage to clinical trial, thanks to the dramatic eradication, in rats, of experimental brain tumor via transfer of herpes virus thymidine kinase,<sup>42</sup> and to the enhancement of immunosurveillance against cancer via transfer of tumor necrosis factor and other cytokines. Gene therapy for acquired immune deficiency syndrome (AIDS) is also close to clinical trials.

Studies from several laboratories, including ours, have provided strong evidence to support the feasibility of gene therapy for vascular diseases. Gene transfer of vasoprotective molecules is a powerful approach to restoring and augmenting vascular protection. Our work on cyclooxygenase gene transfer supports this notion and has laid the foundation for future clinical studies. Vascular gene transfer can also be used to carry antisense oligonucleotides or ribozymes to the proliferating vascular smooth muscle cells, wherein the inciting growth factors, oncogenes, or both, can be suppressed.

To achieve maximal therapeutic efficacy of gene therapy for vascular diseases, the pathophysiology of

the various types of vascular diseases should be taken into consideration; from that point, strategies can be developed in terms of the gene or genes to be altered, the timing and the route of administration of gene vectors, and gene targeting.

In summary, gene therapy for vascular diseases is in its infancy. Aside from several of the technical issues that require resolution, issues involving ethics (such as safety) and cost-effectiveness (comparisons with currently available therapeutic methods) also must be carefully evaluated before gene therapy can be applied to vascular diseases in human beings.

## Acknowledgments

The authors thank Beverly Curbello for excellent secretarial assistance and Clinton Long for technical assistance in performing in vivo experiments.

## References

1. Wu KK. Endothelial cells in hemostasis, thrombosis, and inflammation. *Hosp Pract (Off Ed)* 1992;27:145-50,152,163-6.
2. Wu KK, Kulmacz RJ, Wang L-H, Loose-Mitchell D, Tsai A-L. Molecular biology of prostacyclin biosynthesis. In: Rubanyi GM, Vane J, eds. *Prostacyclin: new perspectives for basic research and novel therapeutic indications*. Amsterdam: Elsevier Science Publishers B.V., 1992:11-23.
3. Tsai A-L, Hsu M-J, Patsch W, Wu KK. Regulation of PGI<sub>2</sub> activity by serum proteins: serum albumin but not high density lipoprotein is the PGI<sub>2</sub> binding and stabilizing protein in human blood. *Biochim Biophys Acta* 1991;1115:131-40.
4. Marlatto MA. Nitric oxide synthase: structure and mechanism. *J Biol Chem* 1993;268:12231-4.
5. Radomski MW, Palmer RMJ, Moncada S. Comparison of pharmacology of endothelium-derived relaxing "factor", nitric oxide, and PGI<sub>2</sub> in platelets. *Int J Pharmacol* 1987;92:181-7.

6. Radomski MW, Palmer RMJ, Moncada S. Endogenous nitric oxide inhibits human platelet adhesion to vascular endothelium. *Lancet* 1987;2:1057-8.
7. ISIS-3 (Third International Study of Infarct Survival) Collaborative Group. ISIS 3: a randomised comparison of streptokinase vs tissue plasminogen activator vs anistreplase and of aspirin plus heparin vs aspirin alone among 41,299 cases of suspected acute myocardial infarction. *Lancet* 1992;339:753-70.
8. Neuhaus K-L, Feuerer W, Jeep-Tebbe S, Niederer W, Vogt A, Tebbe U. Improved thrombolysis with a modified dose regimen of recombinant tissue-type plasminogen activator. *J Am Coll Cardiol* 1989;14:1566-9.
9. The GUSTO Investigators. An international randomized trial comparing four thrombolytic strategies for acute myocardial infarction. *N Engl J Med* 1993;329:673-82.
10. Fiessinger JN, Schafer M. Trial of iloprost versus aspirin treatment for critical limb ischaemia of thromboangiitis obliterans. The TAO Study. *Lancet* 1990;335:555-7.
11. Verma IM. Gene therapy. *Sci Am* 1990;263:68-72,81-4.
12. Mann R, Mulligan RC, Baltimore D. Construction of a retrovirus packaging mutant and its use to produce helper-free defective retrovirus. *Cell* 1983;33:153-9.
13. Wilson JM, Birinyi LK, Salomon RN, Libby P, Callow AD, Mulligan RC. Implantation of vascular grafts lined with genetically modified endothelial cells. *Science* 1989;244:1344-6.
14. Nabel EG, Plautz G, Boyce FM, Stanley JC, Nabel GJ. Recombinant gene expression in vivo within endothelial cells of the arterial wall. *Science* 1989;244:1342-4.
15. Zwiebel JA, Freeman SM, Cornetta K, Forough R, Maciag T, Anderson WF. Recombinant gene expression in human umbilical vein endothelial cells transduced by retroviral vectors. *Biochem Biophys Res Commun* 1990;170:209-13.
16. Kahn ML, Lee SW, Dichek DA. Optimization of retroviral vector-mediated gene transfer into endothelial cells in vitro. *Circ Res* 1992;71:1508-17.
17. Zwiebel JA, Freeman SM, Kantoff PW, Cornetta K, Ryan US, Anderson WF. High-level recombinant gene expression in rabbit endothelial cells transduced by retroviral vectors. *Science* 1989;243:220-2.
18. Flugelman MY, Jaklitsch MT, Newman KD, Casscells W, Brathauer GL, Dichek DA. Low level in vivo gene transfer into the arterial wall through a perforated balloon catheter. *Circulation* 1992;85:1110-7.
19. Herz J, Gerard RD. Adenovirus-mediated transfer of low density lipoprotein receptor gene acutely accelerates cholesterol clearance in normal mice. *Proc Natl Acad Sci U S A* 1993;90:2812-6.
20. Lim CS, Chapman GD, Gammon RS, et al. Direct in vivo gene transfer into the coronary and peripheral vasculatures of the intact dog. *Circulation* 1991;83:2007-11.
21. Leclerc G, Gal D, Takeshita S, Nikol S, Weir L, Isner JM. Percutaneous arterial gene transfer in a rabbit model. Efficiency in normal and balloon-dilated atherosclerotic arteries. *J Clin Invest* 1992;90:936-44.
22. Zhu N, Liggitt D, Liu Y, Debs R. Systemic gene expression after intravenous DNA delivery into adult mice. *Science* 1993;261:209-11.
23. Dichek DA, Neville RF, Zwiebel JA, Freeman SM, Leon MB, Anderson WF. Seeding of intravascular stents with genetically engineered endothelial cells. *Circulation* 1989;80:1347-53.
24. Zoldhelyi P, Xu X-M, Meidell R, et al. Enhancement of prostacyclin synthesis in vitro and in vivo by adenovirus-mediated transfer of prostaglandin H synthase cDNA [abstract]. *Circulation* 1993;88(Suppl 1):I-476.
25. Wu GY, Wu CH. Receptor-mediated in vitro gene transformation by a soluble DNA carrier system. *J Biol Chem* 1987;262:4429-32.
26. Wu GY, Wu CH. Receptor-mediated gene delivery and expression in vivo. *J Biol Chem* 1988;263:14621-4.
27. Wu GY, Wu CH. Evidence for targeted gene delivery to Hep G2 hepatoma cells in vitro. *Biochemistry* 1988;27:887-92.
28. Wu GY, Wilson JM, Shalaby F, Grossman M, Shafritz DA, Wu CH. Receptor-mediated gene delivery in vivo. Partial correction of genetic analbuminemia in Nagase rats. *J Biol Chem* 1991;266:14338-42.
29. Cristiano RJ, Smith LC, Woo SL. Hepatic gene therapy: adenovirus enhancement of receptor-mediated gene delivery and expression in primary hepatocytes. *Proc Natl Acad Sci U S A* 1993;90:2122-6.
30. Smith WL, Marnett LJ. Prostaglandin endoperoxide synthase: structure and catalysis. *Biochim Biophys Acta* 1991;1083:1-17.
31. Hemler ME, Lands WEM. Evidence for a peroxide-initiated free radical mechanism of prostaglandin biosynthesis. *J Biol Chem* 1980;255:6253-61.
32. Egan RW, Paxton J, Kuehl FA Jr. Mechanism for irreversible self-deactivation of prostaglandin synthetase. *J Biol Chem* 1976;251:7329-35.
33. DeWitt DL, Smith WL. Primary structure of prostaglandin G/H synthase from sheep vesicular gland determined from the complementary DNA sequence [published erratum appears in *Proc Natl Acad Sci U S A* 1988;85:5056]. *Proc Natl Acad Sci U S A* 1988;85:1412-6.
34. Xie WL, Chipman JG, Robertson DL, Erikson RL, Simmons DL. Expression of a mitogen-responsive gene encoding prostaglandin synthase is regulated by mRNA splicing. *Proc Natl Acad Sci U S A* 1991;88:2692-6.
35. Kujubu DA, Fletcher BS, Varnum BC, Lim RW, Herschman HR. TIS10, a phorbol ester tumor promoter-inducible mRNA from Swiss 3T3 cells, encodes a novel prostaglandin synthase/cyclooxygenase homologue. *J Biol Chem* 1991;266:12866-72.
36. Xu X-M, Ohashi K, Sanduja SK, Ruan K-H, Wang L-H, Wu KK. Enhanced prostacyclin synthesis in endothelial cells by retrovirus-mediated transfer of prostaglandin H synthase cDNA. *J Clin Invest* 1993;91:1843-9.
37. Rosenfeld MA, Yoshimura K, Trapnell BC, et al. In vivo transfer of the human cystic fibrosis transmembrane conductance regulator gene to the airway epithelium. *Cell* 1992;68:143-55.
38. St. Louis D, Verma IM. An alternative approach to somatic cell gene therapy. *Proc Natl Acad Sci U S A* 1988;85:3150-4.
39. Lynch CM, Clowes MM, Osborne WR, Clowes AW, Miller AD. Long-term expression of human adenosine deaminase in vascular smooth muscle cells of rats: a model for gene therapy. *Proc Natl Acad Sci U S A* 1992;89:1138-42.
40. Wilson JM, Grossman M, Wu CH, Chowdhury NR, Wu GY, Chowdhury JR. Hepatocyte-directed gene transfer in vivo leads to transient improvement of hypercholesterolemia in low density lipoprotein receptor-deficient rabbits. *J Biol Chem* 1992;267:963-7.
41. Chowdhury JR, Grossman M, Gupta S, Chowdhury NR, Baker JR Jr, Wilson JM. Long-term improvement of hypercholesterolemia after ex vivo gene therapy in LDLR-deficient rabbits. *Science* 1991;254:1802-5.
42. Culver KW, Ram Z, Wallbridge S, Ishii H, Oldfield EH, Blaese RM. In vivo gene transfer with retroviral vector-producer cells for treatment of experimental brain tumors. *Science* 1992;256:1550-2.