DNA sequence elements required for regulated expression of the HSV-1 glycoprotein D gene lie within 83 bp of the RNA capsites

R.D.Everett

MRC Virology Unit, Institute of Virology, Church Street, Glasgow G11 5JR, UK

Received 1 August 1983; Revised and Accepted 13 September 1983

ABSTRACT

The genes of Herpes simplex virus type 1 (HSV-1) are classified into three temporally regulated groups. The Immediate-Early (IE) genes are transcribed first by the pre-existing transcription apparatus of the cell. The Early genes are transcribed only after IE-gene expression, and finally the Late genes are activated. The control of transcription of the HSV-1 glycoprotein D (gD) gene (an Early function) was studied by quantitative S1 mapping of RNA produced in HSV-1 infected HeLa cells after short-term transfection experiments using plasmids containing the gD promoter linked to the rabbit β -globin gene. The viral promoter in the plasmid was activated in the same way as that in the virus itself; the RNA showed a similar time-course of appearance, dependence on prior IE-gene expression and pattern of RNA cap-sites. Deletion analysis showed that the DNA sequences necessary for Early promoter activation lie within 83 bp of the RNA cap-sites in this instance. Surprisingly, a plasmid-borne β -globin promoter was also activated by HSV-1 infection. The mechanism of this activation, and DNA sequence similarities between the promoters of HSV-1 Early and rabbit β -globin genes are discussed.

INTRODUCTION

Herpes simplex virus-1 (HSV-1) has a large and complex genome comprising about 150 kb of linear, double-stranded DNA. The genes contained within this DNA molecule have been divided into three temporal classes (1,2,3). The first group, the immediate-early (IE) or α -genes, encode the first viral transcripts and proteins to appear during infection and are defined as those that can be transcribed in the absence of de novo protein synthesis (4,5). The viral early (E) or β -genes are activated by one or more IE-gene products; in the presence of protein synthesis inhibitors no E-gene transcription is detectable (2,6). The IE-3 gene product Vmwl75 (7,8) plays a

crucial role in this transcriptional activation and maintenance since virus mutants with temperature-sensitive lesions in this gene, for example tsK, are unable to activate E-gene transcription at the non-permissive temperature and switch-up of tsK will cause reversion to the IE transcription pattern (9,10,11). The late or δ -genes are less clearly defined and have been divided into two groups. The leaky-late or $\beta\delta$ -genes require E-gene products but not viral DNA replication for their expression while the true-late or δ -genes appear to have a more rigorous requirement for prior template replication before they can be transcribed (1,12,13). The activation of E-gene transcription is fundamental for successful infection by the virus, but is at present poorly understood. A full description of this key process requires an understanding of the host and viral proteins involved and how they interact with and recognise HSV E-gene promoters. Therefore it is necessary to define all the DNA sequence elements required for transcription from an E-promoter, including those involved in regulation.

Previous work in this area has concentrated on the HSV-1 thymidine kinase (tk) gene and its promoter. Using mouse L-cells transformed by the tk gene, various studies have shown that the resident tk gene can be activated by a superinfecting virus (14,15,16). More recently it has been shown that it is the tk promoter element itself which responds to this activation, and that as during normal infection, this regulation is dependent upon an active Vmwl75 protein (17). Again using transformed mouse L-cells, Zipser et.al.(18) have studied the effect of various deletion and insertion mutations within the tk promoter region, and concluded that a complicated arrangement of signals necessary for constitutive or regulated expression, or both, were present. However, the use of transformed cells suffers from many disadvantages. Different cell lines derived from the same transforming plasmid DNA have basal expression levels that vary considerably, presumably depending upon the number, location and state of re-arrangement of the integrated DNA sequences. This introduces some uncertainty into any comparisons between different experiments.

McKnight and colleagues have extensively studied the tk

promoter and its constitutive expression in oocytes (19,20). They have shown that three regions important for constitutive transcription are present within 105 bp upstream of the tk RNA cap-sites (21) and that the distance between these elements is of some importance to their function (22). However, their elegant studies did not address the question of virally regulated expression from the tk promoter.

This report describes experiments to define the promoter elements of the HSV-1 E-gene coding for glycoprotein D (gD). I have constructed a number of deletion mutants within the gD promoter and have studied their virally regulated transcription by quantitation of the RNA produced after superinfection of short-term transfected HeLa cells. The results show that all the signals necessary for full regulated expression lie within 83 bp of the RNA start-sites, and that some promoter activation is still detectable when only 55 bp of upstream DNA sequence are present.

MATERIALS AND METHODS

1. Bacteria, Cells and Virus

The bacteria used were E.coli C600 r⁻m⁻ and the tissue culture cells were HeLa cells grown in Dulbecco's modified Eagles medium supplemented with 2.5% calf serum and 2.5% foetal calf serum (Flow Laboratories). The viruses used were HSV-1 Glasgow strain 17 syn+ (23), HSV-1 tsK (24) and HSV-2 strain HG52 (25).

2. Plasmids

The vector plasmid used with all recombinants was pRE3, a BamHI resistant derivative of pBR322 which confers both tetracycline and ampicillin resistance (26). Plasmid pMD102 contains the HpaII-BamHI early region of SV40, but with bases 35-112 in the early promoter deleted, cloned into the EcoRI site of pRE3. A BamHI linker oligonucleotide is inserted at the deletion point (27). Plasmid pMD10 is similar to pMD102, except that the deletion is from bases 35 to 267 thus removing the entire SV40 enhancer element. Again a BamHI linker is present at the deletion (R.D. Everett, unpublished results). Plasmid pDB2 carries the PvuII fragment containing the entire rabbit

β -globin gene, from position -7 to 400bp beyond the polyadenylation site, cloned into the EcoRI site of pRE3 and with a XhoI linker oligonucleotide inserted at position -7 (R.D. Everett, D.Baty and P. Chambon unpublished results). Plasmid pDB2.SV1 contains the EcoRI-HindIII fragment of pSV1 carrying the SV40 early promoter (28) cloned into the XhoI site of pDB2 such that a HindIII site is regenerated at position -19 relative to the β -globin transcription unit (R.D. Everett, D. Baty and P.Chambon, unpublished results; Figure 1). Plasmid p β (244+) β contains 2 copies of the complete rabbit β -globin gene, including its own promoter, and the polyoma virus enhancer element (29). The source of the HSV-1 gD promoter region was pGX43; HSV-1 BamHI fragment j cloned into pAT153 (F.J.Rixon, personal communication).

3.Construction of Recombinant Plasmids

(i) pSVD2 and pSVD4. pGX43 was cut with BamHI and HindIII, and the fragment containing the gD promoter from bases -2045 to +11 was isolated from a sucrose density gradient. This fragment was ligated with pMD10 that had been cut completely with BamHI, then partially with HindIII. Tetracycline resistant recombinant plasmids were screened; pSVD2 contained the BamHI-HindIII fragment of the gD promoter inserted into pMD10 between the BamHI site at SV40 position 268 and the HindIII site at SV40 position 4002 (Figure 1). pSVD2 was cut with SstI and EcoRI, the ends made flush with E.coli DNA polymerase I Klenow fragment in the presence of all four dNTPs, and ligated in the presence of XhoI linker oligonucleotides to give pSVD4. This plasmid contains only bases +11 to -392 of the gD promoter, with a XhoI linker at position -392. The DNA sequence of this entire HSV-1 region was kindly provided by D.McGeoch (personal communication).

(ii) pRED2 and pRED4. The HindIII fragment of pSVD2 containing the gD promoter was transferred to pDB2.SV1, replacing that containing the SV40 early promoter, to give pRED2, where the β -globin gene is transcribed from the gD sequences. The orientation of the inserted fragment was deduced from restriction enzyme analysis and the exact nucleotide sequence at the gD/ β -globin junction confirmed by DNA sequencing (30)

(Figures 1 and 2). pRED4 was constructed in an analogous fashion from pSVD4 and pDB2.SV1. This procedure was used so that a parallel series of clones could be made containing the SV40 enhancer using pMD102 as the initial vector for pSVD plasmids. Results obtained with these constructions will be described elsewhere.

(iii) Deletion Mutants of pRED4. pRED4 was cut with XhoI and then treated sequentially with Exonuclease III, Mung Bean Nuclease and E.coli DNA polymerase I Klenow fragment in the presence of all four dNTPs before ligation with XhoI linker oligonucleotides. Deletion mutants were screened by restriction enzyme analysis and exact end-points of selected deletions were determined by DNA sequence analysis (30). This strategy resulted in a number of deletion mutants containing between 80 and 350 bp of γ D DNA upstream of the HindIII site (Table 1). To obtain more extensive deletions an identical experiment was carried out using pRED 112 (deletion end-point, -109) as starting material. All of the mutants described here contain an XhoI linker at the deletion.

4. Calcium Phosphate Transfection and Infection of Hela Cells.

Subconfluent Hela cells were transfected (31) with 10 μ g pRED plasmid and 10 μ g p β (244+) per 90mm petri dish. The precipitate was left for 24 hours, the cells washed with Tris-buffered saline and medium, and then 5ml of medium was added to each plate. HSV-1 virus was added to a multiplicity of infection of about 20 p.f.u. per cell and, after 1 hour, a further 5ml of medium was added.

5. RNA Isolation and S1 Mapping Analysis.

Total cytoplasmic RNA was prepared, usually 4 hours after the second medium addition, by NP40 lysis of the cells and extensive phenol-chloroform extraction of the supernatant after the nuclei had been pelleted. The probe for S1 mapping of transcripts from both the γ D/ β -globin hybrid and β -globin genes was the appropriate 5' end-labelled separated strand from the BstNI fragment between position -166 in the γ D region and position +136 in the β -globin gene (see figure 2). The S1 mapping protocol used 10 μ g RNA per incubation with the probe in at least 10-fold molar excess over specific transcripts. RNA

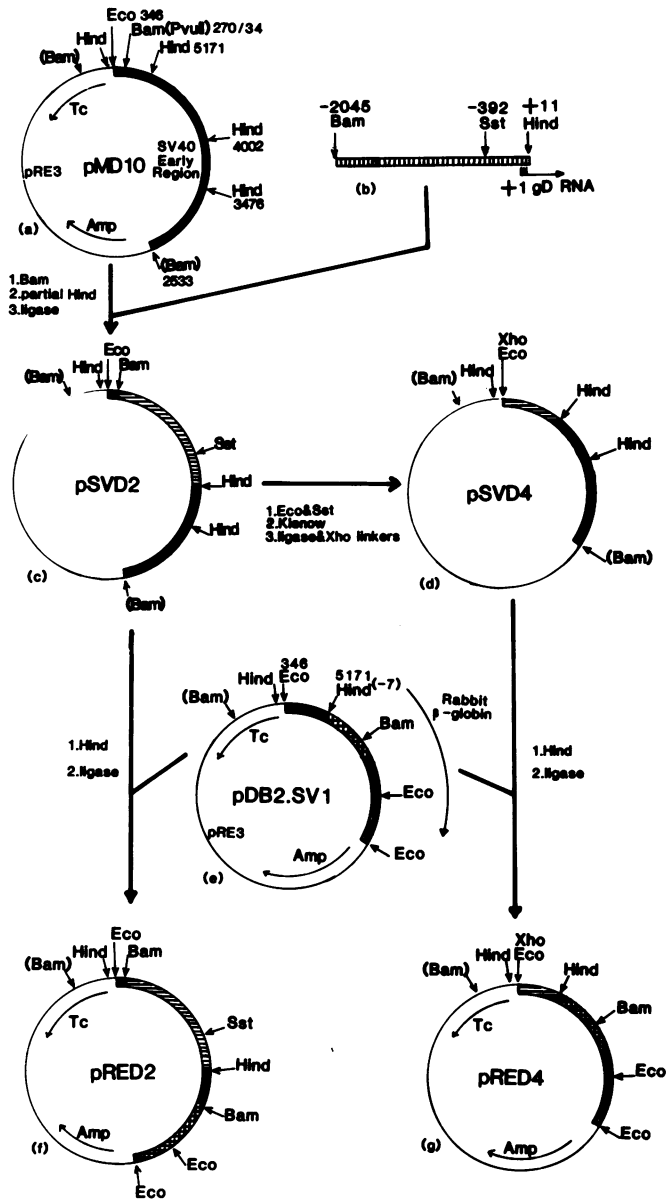

Figure 1. The Construction of pRED series plasmids. (a) : pMD10 ; The HpaII/BamHI Early region fragment of SV40, with a deletion between nucleotides 35 and 267, cloned into a BamHI resistant derivative of pBR322, pRE3. The coordinates (BBB system) show restriction sites within the SV40 sequences. Sites in brackets have been destroyed during manipulation. Eco =EcoRI, Hind=

HindIII, Bam =BamHI, Sst =SstI, Xho =XhoI. The thin line represents pRE3 vector sequences, the thick SV40 sequences. (b) : The BamHI/HindIII region of HSV-1 Bam j fragment. Coordinates are measured from the most upstream of the gD RNA cap-sites (see text). Single-hatched line represents HSV-1 sequences.(c) : pSVD2, constructed from (a) and (b) as shown. (d) : pSVD4; deletion of nucleotides -2045 to -396 of the gD 5' sequences from pSVD2 and insertion of a XhoI linker at this position. Klenow = E.coli DNA Polymerase I Klenow fragment. (e) : pDB2.SV1 ; The rabbit β -globin gene from nucleotide -7 to beyond the polyadenylation site cloned into pRE3, with the SV40 Early promoter upstream as indicated. SV40 coordinates shown (see (a)); double-hatched line = β -globin sequences.(f): pRED2; The SV40 promoter from pDB2.SV1 replaced by the HindIII fragment containing the gD promoter region from pSVD2.(g): pRED4; As pRED2, but the HindIII fragment from pSVD 4 was used.

samples and probe DNA were mixed in a buffer containing 40mM PIPES pH6.5, 1mM EDTA, 400mM NaCl and 50% formamide, heated at 80°C for 5 min., and incubated at 42°C for 12-16 hours. The mixture was diluted into 5 volumes of S1 buffer containing 40mM Na Acetate pH4.5, 1mM ZnSO₄, 400mM NaCl and incubated at 30°C for 3 hours with 5000 units of S1 Nuclease (Boehringer). After phenol/chloroform extraction and ethanol precipitation, protected hybrids were analysed on standard DNA-sequencing gels. The relative activities of promoter mutants were quantitated by densitometer scanning of autoradiograms and measuring the amount of gD promoted transcripts compared to the β -globin transcripts from p β (244+) β , the internal control (see figure 4).

6. Enzymes

Restriction and other nucleases, E.coli DNA polymerase I Klenow fragment, T4 Polynucleotide kinase and T4 DNA ligase were obtained from commercial suppliers and used according to their instructions. Cloning strategies were based on those described in (32).

RESULTS

The Positive Regulation of the HSV-1 Glycoprotein D Promoter can be Reproduced in a Short-Term Transfection Assay.

Transcription of the HSV-1 gD gene is initiated a few bp upstream of a HindIII site; the cap-sites used are unusually numerous, comprising about four purines and four pyrimidines

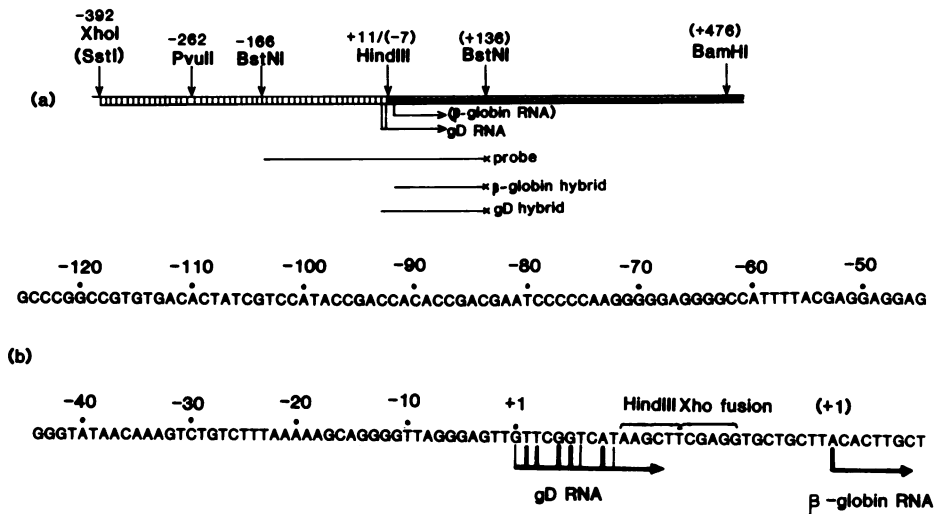

Figure 2. Detailed Structure and Sequence of the gD/β-globin Hybrid Gene Promoter Region in pRED4.(a): The hybrid gene promoter region. Relevant restriction sites are shown ; coordinates in brackets refer to the β-globin gene, the others to the gD promoter. The capsites of the gD and β-globin RNAs are shown. Note that only the gD RNA is produced from the pRED plasmids. The β-globin RNA is produced exclusively from the internal control plasmid pβ(244+)β ; its position is shown to illustrate how the same probe, prepared from pRED2, is able to hybridise with both types of RNA.(b): The DNA sequence of the gD promoter region. The positions of the RNA starts are shown with the preferred capsites shown by thicker lines. The sequence at the HindIII site and Xho fusion resulted from the construction of these plasmids (see figure 1 and Materials and Methods).

spread in three groups over ten bp (33) (R. Everett, unpublished results; figure 2). The pattern of cap-sites observed can vary slightly in relative intensities with different batches of reagents used during the S1 nuclease treatment (compare figures 3 and 4). The behaviour of this promoter is typical of Early genes during HSV-1 infection. During the initial stages of infection there is no transcription of the gD gene, but at about 2 hours after absorption the promoter becomes active, producing maximal concentrations of cytoplasmic RNA at about 4 to 5 hours and continuing for at least 8 hours post-absorption (33) (R.Everett, unpublished data). This promoter can be classified as Early since its activity is dependent upon prior expression

of IE genes. If cycloheximide is added at the start of infection, or the virus mutant HSV-1 tsK (which encodes a thermosensitive IE Vmwl75 protein (8)) is used at the non-permissive temperature, no gD RNA is produced (33) (R.Everett, unpublished data).

To study the DNA sequence requirements of this promoter activation, the region 5' to the gD coding region from nucleotides +11 to -2045 was inserted upstream of the rabbit β -globin coding region such that the gD promoter was used for transcription of the β -globin gene (plasmid pRED2; see Materials and Methods; figures 1 and 2). This approach allows the study of the gD promoter in a recombinant plasmid in short-term transfection experiments while the wild-type viral gene is present in superinfecting virus. In addition, the probe used to detect RNA transcribed from the gD promoter is also able to detect and differentiate the transcripts of the native β -globin gene from the internal control, p β (244+) β , since the β -globin cap-sites are downstream of the gD/ β -globin junction in pRED2 (figure 2). Thus the results from independent experiments using different plasmid constructions can be unequivocally compared.

When pRED2 was transfected into HeLa cells, which were subsequently infected with HSV-1, transcripts from the gD/ β -globin hybrid gene could be detected. The cap-sites used in this hybrid system were identical to those used in the virus (figure 3). Furthermore, the kinetics of induction of the hybrid gene transcripts exactly paralleled those of the analogous viral transcript (Figure 3 and unpublished results). In the absence of viral infection, no hybrid gene RNA was detectable (Figure 4). Therefore the gD promoter was not constitutively expressed in HeLa cells, unlike in oocytes where both this promoter (33) and another HSV-1 early promoter, from the tk gene (19), were constitutively expressed. The positive regulation of the gD promoter in the recombinant plasmid was confirmed by its requirement for IE-gene expression; in the presence of cycloheximide (Figure 3), or when using HSV-1 tsK at the restrictive temperature (result not shown), transcription of the hybrid gene was almost completely eliminated. These properties distinguish this promoter from IE-gene promoters which are also

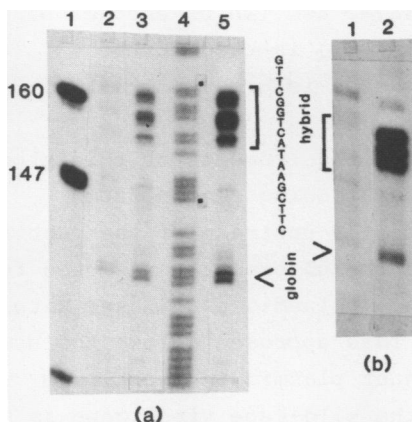

Figure 3. Time-course of Induction of gD/ β -globin Hybrid RNA in pRED2; Inhibition by Cycloheximide. (a) Track 1: size standards. Tracks 2,3,5.: Protected hybrids from S1 mapping of RNAs produced 1,2 and 4 hours after infection of HeLa cells transfected with pRED2 and p β (244+) β . The RNAs derived from the hybrid and β -globin promoters are marked. Track 4.: A+G sequence reaction of the 5'end-labelled probe. The sequence (between the 2 dotted positions) of the complementary strand is

shown on the right. Note that the RNA cap-sites are in reality at 1 base lower on the sequence track than it appears because of the chemistry of the Maxam and Gilbert reactions. (b) Track 1.: RNAs produced from infected HeLa cells transfected with pRED119, with cycloheximide present at 100 μ g/ml.. Track 2.: Control without cycloheximide.

positively regulated by superinfecting virus (34) but by a component of the virus inoculum itself (35,36) in a process that does not require viral gene expression.

These results show that the gD promoter in the hybrid gene of the recombinant plasmid pRED2 responds faithfully to the normal parameters of early gene regulation during HSV-1 infection. Therefore this system is suitable for analysis of the DNA sequence requirements for regulation of gD promoter activity.

DNA Sequences Required for Early Gene Regulation are Contained Within 83 bp of the RNA Capsites.

The results described above show that the sequences required for the positive regulation of the gD promoter lie between -2045 and +11 compared to the most 5' cap-site. To locate the required sequences in more detail, the region from -2045 to -392 was deleted from pSVD2 to give pSVD4. The relevant HindIII fragment from pSVD4 was transferred to pDB2.SV1 to give pRED4 (see Materials and Methods, and Figure 1). This plasmid

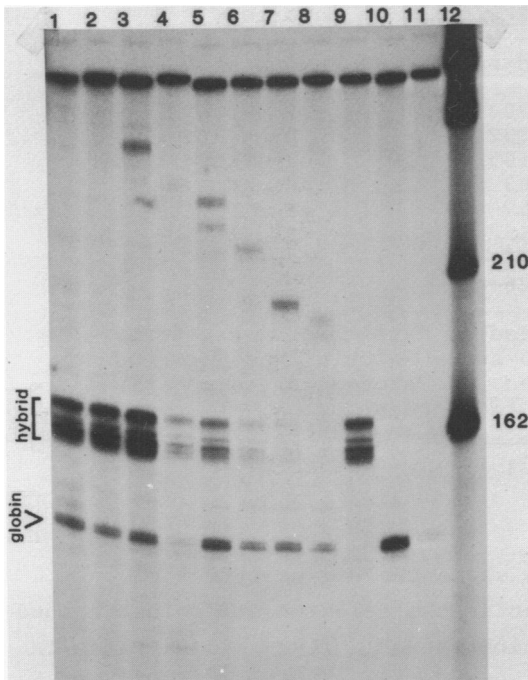

Figure 4. Comparison of Transcriptional Activation of pRED Plasmids. RNAs produced from HSV-1 infected Hela cells after transfection with p β (244+) β plus, tracks 1-8, pRED2, pRED4, pRED112, pRED119, pRED111, pRED123, pRED122, pRED121. Track 9.:pRED2 alone. Track 10.:p β (244+) β alone. Track 11.: pRED2 plus p β (244+) β without infection. RNAs produced from the hybrid and control β -globin genes are marked. Note that the transfection using pRED119 (track 4) was not as successful as the others in this experiment, but the internal control allows reliable quantitation.

and pRED2 gave identical results (Figure 4, Table 1). During the construction of pRED4 a XhoI linker was incorporated at position -392. This was used as an entry-point to construct a family of 5' deletion mutants extending progressively further towards the hybrid gene cap-sites. The end-points of these deletion mutants were mapped by the position of the Xho I linker incorporated at the deletion and by DNA sequence analysis. These mutants and their end-points are listed in Table 1.

These plasmids were then transfected into Hela cells, the cells infected with HSV-1 and RNA prepared 4 hours after infection. Typical results obtained by S1 mapping are shown in figure 4. The bands were scanned with a densitometer, and the ratio of hybrid gene transcripts to β -globin internal control transcripts determined. Table 1 summarises the results from at least two experiments for each of at least two independent

Table 1. The Expression of pRED Deletion Mutants.

Plasmid	End-point	Expression
pRED 2	-2045	92 (5)
pRED 4	-392	100 (4)
pRED 112	-109	102 (7)
pRED 119	-83	109 (4)
pRED 111	-67	19 (5)
pRED 123	-55	9 (3)
pRED 122	-33	<4 (4)
pRED 121	-26	<2 (4)

Autoradiographs were analysed by densitometric scanning. The peaks corresponding to the α D and β -globin RNAs were cut out, weighed, and ratios determined. The expression values given are average percentages of the ratio obtained with pRED4 over the stated number of experiments, using at least 2 different plasmid DNA preparations in each case.

preparations of each plasmid.

Deletion of upstream sequences had no effect on inducible promoter activity until the deletion end-point reached nucleotide -67 in pRED111, which showed a five-fold decrease in transcription. Therefore sequence elements between nucleotides -68 and -83 have some role in the α D promoter because pRED119 with an end-point at -83 was fully active. Further deletion beyond -67 resulted in successive reductions in transcription; pRED123 with an end point at -55 showed at least a 10-fold reduction in transcription while pRED121 and pRED122 with end-points at -26 and -33 respectively, gave only trace levels of RNA (figure 4, Table 1). Therefore important elements of the α D promoter lie within nucleotides -67 to -55. Since constitutive expression from the α D promoter is undetectable in these experiments, it is not possible to conclude whether the sequences between -67 and -55 are involved in regulated activation of the promoter, "intrinsic" promoter activity, or both (see below). Further experiments will be necessary to define all the functional elements within the α D promoter.

DISCUSSION

This report describes the use of a short-term transfection assay to estimate the regulated activity of an HSV-1 E-gene promoter by quantitative S1 mapping. There are several advantages of this

system. By linking the gD promoter to the rabbit β -globin gene, the activity of the hybrid gene promoter can be monitored in the presence of its viral counterpart during superinfection.

Therefore any viral promoter could be studied by this method.

A β -globin transcription unit linked to the Polyoma virus enhancer element acts as an internal control in all transfection experiments so that one can accurately quantitate the hybrid gene promoter activity with the same labelled probe for both transcripts. All the transcripts mapped at the normal

β -globin cap-sites are derived from p β (244+) β since this cap-site region is not used by the pRED plasmids (figure 4).

This assay appears to closely approach the conditions that occur during normal infection. The transfected DNA is almost certainly not integrated into the chromosomes over the time-course of these experiments, and as neither plasmid nor viral DNA molecules are packaged into chromatin before entry into the nucleus (37) the hybrid gene promoter may closely resemble the physical state of its viral counterpart during transcriptional activation. The HeLa cells used are a human cell-line; since HSV-1 normally infects man, conditions and host-factors should reflect those present during normal lytic infection.

The results demonstrate that all signals necessary for fully regulated transcription from the gD gene promoter lie between nucleotides -83 and +11 relative to the most upstream cap-site (Figure 2). However the possibility that these data are due to preferential RNA stabilisation cannot be excluded.

Because of the homology between HSV-1 and pDB2 vector DNA at and just beyond the HindIII site at the junction of the sequences in the pRED plasmids, the +11 co-ordinate could be considered +17.

The strength of the activation of the gD promoter in the hybrid gene by superinfecting virus is astonishing. Precise quantitation is difficult because the uninduced level of expression was not detectable. However, densitometric scanning indicated an approximate 50-fold increase in hybrid gene RNA between 1 and 4 hours after infection. This corresponds to 10-fold more RNA produced in 4 hours from the activated E-gene promoter than from the control β -globin promoter with the Polyoma virus enhancer in 28 hours. Even this may underestimate

the relative strengths of HSV induced E-gene and Papovavirus enhanced promoter activation (in HeLa cells) because, surprisingly, the β -globin promoter was also activated by HSV superinfection (figure 3). This activation of the β -globin gene was approximately 5-fold over the 4 hour infection period, and it also occurred in plasmids containing the complete β -globin gene without the Polyoma enhancer element (results not shown).

Infection by HSV-2 also activates the α D and β -globin promoters in this system (result not shown), but this was expected because HSV types 1 and 2 can form functional intertypic recombinants within the IE-3 (Vmw 175) gene (7). That the β -globin promoter is also activated by HSV-1 infection in these experiments raises the question of the specificity of E-gene activation. Indeed the activation may not be specific but simply reflects an increased rate of transcription in the infected cell. This is unlikely since host transcription is not generally activated during infection (38) and while E-gene promoters resident in the host chromosome in transformed cell lines can be activated by superinfecting virus (see Introduction), preliminary results indicate that the β -globin gene in rabbit kidney cells is not activated during HSV-1 infection. Alternatively, sequence elements within E-gene promoters that respond to IE-gene product activation may also be present in the rabbit β -globin promoter (see below), or extra-chromosomal promoters may be preferentially activated. It is possible that elements of both these explanations apply.

Previous work on the regulation of HSV gene expression has concentrated on the IE-genes. It has been shown that a hybrid tk-gene with an IE-promoter is regulated like an authentic IE-gene (34). This system of regulation includes "far-upstream" sequences, possibly in multiple copies, which can activate near-by promoter elements. The stimulation of transcription occurs in the absence of, but is substantially increased by, viral infection (39,40,41,36). The viral activation of IE-genes is probably brought about by an unidentified component of the virus particle (35) which, by itself, is unable to activate E-gene transcription. This latter event requires Vmw175 and perhaps other IE-gene products.

Therefore these two transcriptional activation mechanisms, although perhaps similar in outline, must differ in detail.

The deletion analysis shows that the signals for positive regulation of the gD promoter lie within 83 bp of the RNA cap-sites. Furthermore, at least some functional signals must be downstream of position -55; both pRED111 and pRED123 (with end-points at -67 and -55) show some virus activated transcription. The junction sequences in these plasmids are one or more Xho linkers (5' CCTCGAGG 3') adjoining different pBR322 sequences in each case. Those in pRED111 and pRED123 (3 Xho linkers each) are at coordinates 324 and 445 respectively, and do not re-form sequence homologies with the gD sequence. However, in pRED111 the Xho linker results in homology to position -69.

In the absence of superinfection no hybrid gene RNA could be detected with any of these plasmids, not even with pRED2 where 2045 bp of 5' sequence are present. However, the progressive reductions in transcription with pRED111 and pRED123 may reflect the loss of promoter elements analogous to the "upstream" sequences identified in other promoters recognised by RNA polymerase II (B) (27 and refs therein, 42, but see below). It may be relevant that Zipser et. al. (18) observed the loss of viral activation of a HSV-1 tk gene promoter resident in mouse L-cells when a small insertion was present at position -50, while two of the elements important for constitutive expression of the tk gene in *Xenopus* oocytes lie between positions -80 to -105 and -47 to -61 (21).

Studies of other inducible gene systems such as the interferon gene family and the *Drosophila* heat-shock genes have revealed homologous sequences within the promoter elements which are functionally important (43,44). Thus it might be expected that there would be strong homologies amongst the DNA sequences of HSV-1 E-gene promoters. Computer analysis of the 120 bp upstream of the gD RNA cap-sites indicates that there are two sets of directly repeated sequences. These include an overlapping tandem duplication of the sequence 5'CCATACCGAC 3' (with one mismatch at the T) between positions -102 and -84, and 3 copies of related G-rich sequences (5'AGGGGGAGGGGC 3',

5'AGGAGGAGGGGT 3', and 5' AGCAGGGGT 3') between positions -73 and -61, -52 and -41, and -18 and -10 respectively (see figure 2). There is only one possible hair-pin structure. This is found between positions -80 and -67, and forms a short inverted repeat which overlaps the most upstream G-rich sequence. pRED119 retains all of the G-rich repeats and shows unimpaired transcriptional activation while pRED111 and pRED123, which have partially or completely lost the most upstream of these sequences, are poorly activated by superinfecting virus. Furthermore, pRED122 and pRED121 show only trace levels of RNA after viral infection and have lost both the G-rich repeats upstream of the TATA-box. However, these results do not identify these sequences as regulatory elements per se because they may be important transcriptional elements which do not interact directly with the proteins responsible for activation.

Comparison of the 115 bp upstream of the γ D RNA cap-sites with the analogous regions of other HSV-1 E-gene promoters shows several interesting features (Table 2). The most important points are given here, while the fine details may be found in the legend to Table 2. There are no obvious sequences present at equivalent positions in all of the genes. However, the AC-rich repeat is well conserved both in sequence and position in many of them. The G-rich repeated sequences are rarely present in the same orientation as those in the γ D promoter, but frequently in the inverse orientation. The positions of these inverted homologues varies quite widely, but they are sometimes present at approximately equivalent locations. Sometimes multiple copies of the inverted sequence are found, for example in the 38K gene promoter. The G-rich sequence has been detected in the "upstream" region of several promoters of another Herpes virus, EBV (45), and is also present in the rabbit β -globin promoter (Table 2). The inverse of the G-rich sequence is very similar to the C-rich elements which have been identified as important constitutive elements of the HSV-1 tk, SV40 Early and rabbit β -globin promoters (21,27,42). In the case of the SV40 Early promoter, this sequence was found to be equally functional in both orientations (27). Comparison of these E-promoter sequences with HSV IE-gene promoters shows

Table 2. Comparison of the DNA sequences of the gD and other HSV Early Promoters. The gD sequence from position -120 to +1 is shown. The sequences from other genes are shown to maximise homology between the sequence elements, but they are not necessarily present in equivalent locations. Sequences in inverted commas are inverted. The locations of the sequences are as follows (given from left to right and each line in turn,) :
 gD: ((47) D.McGeoch, personal communication) bases -115 to -56.
 ; tk: (HSV-1 thymidine kinase (48)) -113 to -106, -107 to -101, -58 to -51, -73 to -82 and -97 to -104. ; 52: (HSV-1 5.2 kb RNA, (49)) -109 to -103, -65 to -71, -100 to -108 and -39 to -48. ; 38: (HSV-1 1.5kb RNA coding for 38K protein, (50)) -118 to -110, -109 to -103, -62 to -71, -51 to -58 and -31 to -39. ; 1.5: (HSV-1 1.5kb RNA at 0.696 mu, (51)) -102 to -94, -56 to -70 and -51 to -44. ; 1.52: (HSV-1 1.5kb RNA at 0.699 mu, (50)) -109 to -102, -108 to -118 and -83 to -89. ; bg: (rabbit β -globin) -106 to -99, -74 to -68, -64 to -53, -94 to -85 and -99 to -106. ; gD: bases -55 to +1. ; tk: -97 to -105 and -28 to -20. ; 52: -39 to -47 and -27 to -18. ; 38: -84 to -75, -52 to -64, -29 to -21 and -33 to -46. ; 1.5: -107 to -119 and -25 to -17 ; 1.52: -108 to -118 and -13 to -5. bg: -63 to -56 and -30 to -17. Some of the sequences in the region -55 to +1 are subsets of those homologies given for bases -120 to -56.

	-110	-100	-90	-80	-70	-60
gD;	GTGACACTATCGTCCATACCGACCAACCCGACGAATCCCCCAAGGGGGAGGGGCCATTTT					
tk;	TGACACAA			AAACCCC	GTCGGGGC	
				'CGAATTTCGCC'	'GGGCGGGG'	
52;			AC ACACC	'GAAACCC'	'GGGGGTGTG'	
					'GCGGTGGGGC'	
38;	CGACCATAG			CCAATCC	'GGGAGGGTCC'	
					'GGGTGGAG'	
					'GTGGAGGAG'	
1.5;		CCGAGACCG		'ACCAATCCCC	AGGGG'	
					CCCATGGG	
1.52;		CCACACAG			'GGGTGAGGGG'	
					'GGGCAGG'	
bg;		CCTCACC		GCCAATCT	CACGGGGTAGGG	
		GAGCCACACC			'GGGTGAGG'	
	-50	-40	-30	-20	-10	+1
gD;	ACGAGGAGGAGGGGTATAACAAAGTCTGTCTTTAAAAGCAGGGGTAGGGAGTTG					
tk;	'GGGCGGGG'			GCATATTAA		
52;	'GCGGTGGGG'			GATAAAAAGC		
38;	GAGAAGGCCG					
	'GGTGGAGGCTGGG'			CATATAAGC		
	'GGAGGAGAAGGCCG'					
1.5;	'CGCGAAGAAGGGG'			CCTATAAGA		
1.52;	'GGGTGAGGGGT'			TACATAAAA		
bg;	ACGGGGTA			CATAAAAGGCAGAG		

that the G- or C-rich runs are common in both (46). The AC-rich motif and the "CAAT" homology are not so evident in IE-promoters. Further functional studies will be necessary to define the DNA sequences which differentiate E- from IE-promoters.

The mechanism of E-gene activation during HSV infection is still open to question. This work suggests that the G-rich sequences are important, but does not identify them as "activator" elements. If the rabbit β -globin promoter is activated in these experiments because it contains a G-rich related sequence, then it could be that many other viral or (extra-chromosomal) cellular promoters containing similar elements would also be activated by HSV-1 infection. Whether this activation occurs due to direct recognition of E-gene promoters by IE-gene products, through modification of RNA polymerase II (B) or other transcription factors, or more fundamental re-organisation of the transcription machinery, remains to be determined.

ACKNOWLEDGEMENTS. The author, a member of the Medical Research Council Virology Unit, thanks Professor J.H.Subak-Sharpe for his interest and encouragement, Dr.Frazer Rixon for pGX43, Dr. W. Schaffner for p β (244+) β , Dr.Duncan McGeoch for vital sequence information, Dr. Lindsay Whitton for discussion and helpful comments on the manuscript and Mr. Matt Dunlop for technical assistance. Some plasmids were made while I was working in the laboratory of Professeur Pierre Chambon in Strasbourg.

REFERENCES

1. Swanstrom,R.I. and Wagner,E.K. (1974) Virology 60, 522-533.
2. Clements,J.B., Watson,R.J. and Wilkie,N.M. (1977) Cell 12, 275-285.
3. Jones,P.C. and Roizman,B. (1979) J.Virol. 31, 299-314.
4. Kozak,M. and Roizman,B. (1974) Proc. Natl. Acad. Sci. U.S.A. 71, 4322-4326.
5. Costanzo,F., Campadelli-Fiume, G., Foa-Tomasi,L. and Cassai,E. (1977) J.Virol. 21,996-1001.
6. Jones,P.C., Hayward,G.S. and Roizman,B. (1977) J.Virol. 21, 268-276.
7. Dixon,R.A.F. and Schaffer,P.A. (1980) J.Virol. 36, 189-203.
8. Preston,V.G. (1981) J.Virol. 39, 150-161.
9. Preston,C.M. (1979) J.Virol. 29, 275-284.
10. Watson,R.J. and Clements,J.B. (1978) Virology 91, 364-379.
11. Watson,R.J. and Clements,J.M. (1980) Nature 285, 329-330.
12. Powell,K.L., Purifoy,D.J.M. and Courtney,R.J. (1975) Biochem. Biophys. Res. Commun. 66, 262-271.

13. Holland, L.E., Anderson, K.P., Stringer, J.R. and Wagner, E.K. (1979) *J. Virol* 31, 447-462.
14. Leiden, J.M., Buttyan, R. and Spear, P.G. (1976) *J. Virol.* 20, 413-424.
15. Kit, S. and Dubbs, D.L. (1977) *Virology* 76, 331-340.
16. Buttyan, R. and Spear, P.G. (1981) *J. Virol.* 37, 459-472.
17. Reyes, G.R., Gavis, E.R., Buchan, A., Raj, N.B.K., Hayward, G.S. and Pitha, P.M. (1982) *Nature* 297, 598-601.
18. Zipser, D., Lipsich, L. and Kwoh, J. (1981) *Proc. Natl. Acad. Sci. U.S.A.* 78, 6276-6280.
19. McKnight, S.L. and Gavis, E.R. (1980) *Nucleic Acids Res.* 8, 5931-5948
20. McKnight, S.L., Gavis, E.R. and Kingsbury, R. (1981) *Cell* 25, 385-398.
21. McKnight, S.L. and Kingsbury, R. (1982) *Science* 217, 316-324.
22. McKnight, S.L. (1982) *Cell* 31, 355-365.
23. Brown, S.M., Ritchie, D.A. and Subak-Sharpe, S.H. (1973) *J. gen. Virol.* 18, 329.
24. Marsden, H.S., Crombie, I.K. and Subak-Sharpe, J.S. (1976) *J. gen. Virol.* 31, 347-372.
25. Timbury, M.C., Theriault, A. and Elton, R.A. (1974) *J. gen. Virol.* 23, 219.
26. Moreau, P., Hen, R., Wasyluk, B., Everett, R.D., Gaub, M.P. and Chambon, P. (1981) *Nucleic Acids Res.* 9, 6047-6068.
27. Everett, R.D., Baty, D. and Chambon, P. (1983) *Nucleic Acids Res.* 11, 2447-2464.
28. Benoist, C. and Chambon, P. (1980) *Proc. Natl. Acad. Sci. U.S.A.* 77, 3865-3869.
29. de Villiers, J. and Schaffner, W. (1981) *Nucleic Acids Res.* 9, 6251-6264.
30. Maxam, A. and Gilbert, W. (1980) in *Methods in Enzymology*, Grossman, L. and Moldave, K. Eds. Vol. 65, 43-62. Academic Press, New York.
31. Corsalo, C.M. and Pearson, M.L. (1981) *Genetics* 7, 603-616.
32. Lathe, R., Everett, R.D. and LeCoq, J.P. (1983) in *Genetic Engineering Vol. 4* Ed. R. Williamson. Academic Press, London.
33. Watson, R.J., Colberg-Poley, A.M., Marcus-Secura, C.J., Carter, B.J. and Enquist, L.W. (1983) *Nucleic Acids Res.* 11, 1507-1522.
34. Post, L.E. Mackem, S. and Roizman, B. (1981) *Cell* 24, 555-565.
35. Batterson, W. and Roizman, B. (1983) *J. Virol.* 46, 371-377.
36. Cordingly, M.G., Campbell, M.E.M. and Preston, C.M. (1983) *Nucleic Acids Res.* 11, 2347-2365.
37. Leinbach, S.S. and Summers, W.C. (1980) *J. gen. Virol.* 51, 45-59.
38. Stenberg, R.M. and Pizer, L.I. (1982) *J. Virol.* 42, 474-487.
39. Mackem, S. and Roizman, B. (1982a) *Proc. Natl. Acad. Sci. U.S.A.* 79, 4917-4921.
40. Mackem, S. and Roizman, B. (1982b) *J. Virol.* 43, 1015-1023.
41. Mackem, S. and Roizman, B. (1982c) *J. Virol.* 44, 939-949.
42. Dierks, P., van Ooyen, A., Cochran, M., Dobkin, C., Reisser, J. and Weissman, C. (1983) *Cell* 32, 695-706.
43. Ragg, H. and Weissman, C. (1983) *Nature* 303, 439-442.
44. Pelham, H.R.B. and Bienz, M. (1982) *EMBO Journal* 1, 1473-1477.
45. Farrell, P.J., Deininger, P.L., Bankier, A. and Barrell, B. (1983) *Proc. Natl. Acad. Sci. U.S.A.* 80, 1565-1569.

46. Whitton, J.L., Rixon, F.J., Easton, A.E. and Clements, J.B. (1983) *Nucleic Acids Res.* in press
47. Watson, R.J., Weiss, J.H., Salstrom, J.S. and Enquist, L.W. (1982) *Science* 218, 381-384.
48. McKnight, S.L. (1980) *Nucleic Acids Res.* 8, 5949-5964.
49. Frink, F.J., Draper, K.G. and Wagner, E.K. (1981) *Proc. Natl. Acad. Sci. U.S.A.* (1981) 78, 6139-6143.
50. McLauchlan, J. and Clements, J.B. (1983) *J.gen.Virol.* 64, 997-1006.
51. Hall, L.M., Draper, K.G., Frink, F.J., Costa, R.H. and Wagner, E.K. (1982) *J.Virol.* 43, 594-607.