9-[(10-(aden-9-yl)-4,8-diazadecyl)amino]-6-chloro-2-methoxy-acridine incises DNA at apurinic sites

J.F.Constant, T.R.O'Connor¹, J.Lhomme and J.Laval^{1*}

LEDSS (UA CNRS 332), Chimie Recherche, Université Scientifique et Médicale de Grenoble, BP 68, 38402 Saint-Martin d'Herès and ¹Groupe Réparation des Lésions Radio et Chimio Induites, UA 147 CNRS and U 140 INSERM, Institut Gustave Roussy, 94805 Villejuif Cédex, France

Received November 25, 1987; Revised and Accepted February 19, 1988

ABSTRACT

The incision of DNA at apurinic/aprimidinic sites (AP-sites) by chloro-6-methoxy-2-((adenyl-9)-11)-4,8 diazadecyl)amino-9 acridine (Ade-Z-Acr), a 9-aminoacridine linked to an adenine, at nanomolar concentrations is described. Moreover, this drug, Ade-Z-Acr, is one of the most efficient drugs which cleaves DNA at AP-sites. The high activity is the result of the composition of the drug, since the individual components have no incising activity in the concentration range studied. The termini left by the Ade-Z-Acr molecule are a 3'deoxyribose and a 5'nucleotide. The termini and the inability of the Ade-Z-Acr to incise DNA with reduced AP-sites suggest that the mechanism of cleavage is β -elimination.

INTRODUCTION

Apurinic/aprimidinic sites (AP-sites) are created by different mechanisms such as spontaneous depurination or treatment with X-ray or ultraviolet radiation (1). In addition, in vivo, physiological repair of altered DNA bases by DNA glycosylases also creates AP-sites (2,3). Therefore, since AP-sites are believed to alter processes associated with DNA replication (4,5), the repair of AP-sites in DNA is a critical cellular activity.

Previously we have studied the properties of AP endonucleases (6) and agents which mimic DNA endonuclease activity (7). One series of drugs which incise DNA at AP-sites, the ellipticines, has demonstrated effectiveness clinically in combination chemotherapy (8-12). The activity of the ellipticines used in combination chemotherapy may result from binding to DNA at AP-sites which may subsequently inhibit mechanisms of repair at these sites (10). Thus, to further evaluate the role of AP-sites in vitro and in vivo, we synthesized a series of molecules with subtle changes in structure to act as inhibitors of AP-endonuclease activity (13). In this study, we coupled a 9-aminoacridine with an adenine using different linking chains to create molecules with intercalating properties which specifically recognize AP-sites. However, in evaluating the binding of these molecules to DNA at AP-

sites, we discovered that chloro-6 methoxy-2 ((adenyl-9)-11)-4,8 diazadecyl amino-9 acridine (Ade-Z-Acr) incises DNA specifically at AP-sites, and that moreover, this cleavage of DNA occurs at nanomolar concentrations of this compound. Additionally, we found that the coupling of the two functional groups by a specific linker enhances the ability of the components to incise DNA at low concentrations. We also determined the termini following cleavage by Ade-Z-Acr and suggest a mechanism for the catalysis.

MATERIALS AND METHODS

Enzymes

Exonuclease III of E. coli was obtained from Gibco-BRL. T4 polynucleotide kinase (3'-phosphatase free), DNA polymerase I, bacterial alkaline phosphatase and calf intestine phosphatase were obtained from Boehringer-Mannheim. AP-endonucleases A and B of Micrococcus luteus were prepared as previously described (14).

DNA

Covalently, closed-circular, double-stranded pBR322 DNA was prepared by a standard boiling method (15). PM2 DNA was purchased from Boehringer-Mannheim.

Preparation of DNA containing AP-sites (AP-pBR322 DNA)

pBR322 DNA or PM2 DNA was dissolved in 25 mM sterilized sodium acetate buffer at a concentration of 1 mg/ml and heated at 70°C for 17 min (7). This treatment introduced about 1.8 AP-sites per DNA molecule.

Preparation of organic molecules

The following compounds have been prepared as previously described : Ade-C₃-Acr (16), Acr-Z (17), Ade-C₅-Acr and Ade-C₆-Acr (18). The synthesis of Ade-Z and Ade-Z-Acr will be described elsewhere. All compounds were tested for purity by microanalysis, ¹H nmr spectroscopy, high performance liquid chromatography, and thin-layer chromatography in different solvent systems. Ade-Z-Acr, Ade-Z, and Z-Acr were dissolved in sodium acetate buffer 0.1 M containing 5 % (v/v) of ethanol to a concentration of about 125 μM. Exact concentration was measured using molar absorptivities of 8700 l-cm⁻¹ mole⁻¹ at 422 nm, 13150 l-cm⁻¹ mole⁻¹ at 260 nm, and 9500 l-cm⁻¹ mole⁻¹ at 422 nm for Ade-Z-Acr, Ade-Z, and Z-Acr, respectively. The final dilutions of the compounds were in the standard reaction buffer of 25 mM Hepes-KOH, 2 mM EDTA, 25 mM NaCl, pH 7.5.

Incision of AP-pBR322 DNA

0.2 μg of AP-pBR322 DNA was incubated at 37°C for 20 min in the presence

of the various compounds in standard reaction buffer. The reaction was stopped by extracting the compounds using butanol saturated with water. The relative amounts of nicked and supercoiled DNA molecules were measured after separation by agarose gel electrophoresis (0.8 %) as previously described (7). The absolute number of nicks in the DNA population was calculated assuming a Poisson distribution (19). For incision of DNA containing AP-sites by the AP-endonuclease activity of Exonuclease III (Exo III), the following reaction mixture was used : 0.2 μg of DNA containing AP-sites in 50 mM Tris-HCl, 5 mM MgCl_2 , pH 8.0, and a saturating amount of enzyme (25 units). The enzyme was inactivated by heating for three minutes at 70°C followed by assays for nicking and/or DNA polymerase I elongation. Experiments on the effect of ionic strength were performed at 2, 10, 25, 70 and 100 mM NaCl.

Preparation of incised AP-pBR322 DNA for the determination of the cleavage site

10 μg of AP-pBR322 DNA was reacted with Ade-Z-Acr, Exo III, or Lys-Trp-Lys using conditions described above for Ade-Z-Acr and conditions described previously for the other two agents which recognize and cleave at AP-sites (7,20). The reactions were stopped and the DNAs were purified.

End labeling of DNA with T_4 polynucleotide kinase

2.0 μg of incised DNA was reacted with 5 units of T_4 polynucleotide kinase and 5 μl of [γ - ^{32}P]ATP (specific activity 1200 Ci/mole 2.5 mCi/ml) in a total volume of 11 μl . At $t = 20$ min, acid insoluble radioactivity was assayed.

Nick translation of incised AP-pBR322 DNA with *E. coli* DNA polymerase I

The method was similar to that used by Linn et al. (21,22). Reaction mixtures (250 μl) contained 50 mM Tris-HCl buffer (pH 8.0), 10 mM MgSO_4 , 0.1 mM dithiothreitol, 0.5 mg/ml of Bovine Serum Albumin and 20 μM each of dGTP, dCTP, and dTTP, 5 μCi of [^3H]-dATP (1 Ci/mole), 2.0 μg of AP-pBR322 DNA, and 10 units of *E. coli* DNA polymerase I. After incubation at 16°C for various periods of time, 50 μl aliquots were withdrawn and assayed for acid insoluble radioactivity.

Reduction of AP-pBR322 DNA

Reduced AP-pBR322 DNA was prepared according to the method described by Pierre and Laval (7). Briefly, 20 μg of AP-pBR322 at a concentration of 1 mg/ml in 10 mM Tris-HCl, 1 mM EDTA, pH 8.0 was placed in a 1.5 ml Eppendorf centrifuge tube. 6.6 μl of a 2 M solution of potassium phosphate, pH 6.5 was added. A solution of fresh NaBH_4 , 5 M, was prepared by adding 190 mg of NaBH_4 to 800 μl of H_2O and centrifuging the solution 20 seconds to pellet

excess NaBH_4 . 2 μl of the 5 M NaBH_4 was added to the AP-DNA solution and reacted for 15 min. At 15 and 30 min., 2 μl of the 5 M NaBH_4 solution was added. After the addition at 30 min., the reaction was incubated for another 1h. The reduced DNA was purified by microdialysis followed by precipitation with ethanol.

RESULTS

Ade-Z-Acr cleaves specifically at AP-sites

The molecules shown in Fig. 1, were originally designed as potential inhibitors of AP-endonucleases. The competition assays designed to test that hypothesis, however, showed that these molecules did not inhibit the AP-endonucleases A and B from Micrococcus luteus or the AP-endonuclease activity of exonuclease III from E. coli (data not shown). However, the control reaction containing only Ade-Z-Acr revealed that the AP-pBR322 DNA was incised. Since none of the other molecules originally designed as inhibitors showed this activity, we investigated the ability of the Ade-Z-Acr to incise the DNA at AP sites. We prepared pBR322 molecules with different amounts of AP-sites by heating the pBR322 DNA at 70°C as a function of time. The DNAs with different amounts of AP-sites were then incubated in the presence of Ade-Z-Acr. The number of AP-sites was calibrated using the endonuclease activity of Exo III which cleaves DNA at AP-sites. Following the incubation, the reactions were stopped, and the DNA was electrophoresed to quantify the supercoiled and nicked species. Fig. 2 shows that as the time of incubation at 70°C of the pBR322 DNA increases, the number of AP-sites in the DNA increases as indicated by Exo III cleavage. As the number of AP-sites increases, cleavage by Ade-Z-Acr generates the same number of nicked species as incision by Exo III. Therefore, the Ade-Z-Acr reaction is consistent with recognition and cleavage at AP-sites.

Dependence of Ade-Z-Acr incision of AP-pBR322 DNA on concentration, ionic strength, and supercoiling

To determine the efficiency of the incising agent, we titrated the Ade-Z-Acr against a constant amount of AP-pBR322 DNA. The curve in Fig. 3 shows cleavage of AP-pBR322 DNA by Ade-Z-Acr. This curve demonstrates that there is significant incision of the DNA at AP-sites even at 20 nM concentrations.

In addition to the influence of the concentration of the incising agents, the incision of AP-DNA using Ade-Z-Acr was studied as a function of ionic strength and supercoiling. When the cleavage of AP-pBR322 DNA was performed at concentrations of NaCl from 2 mM to 100 mM there was no change

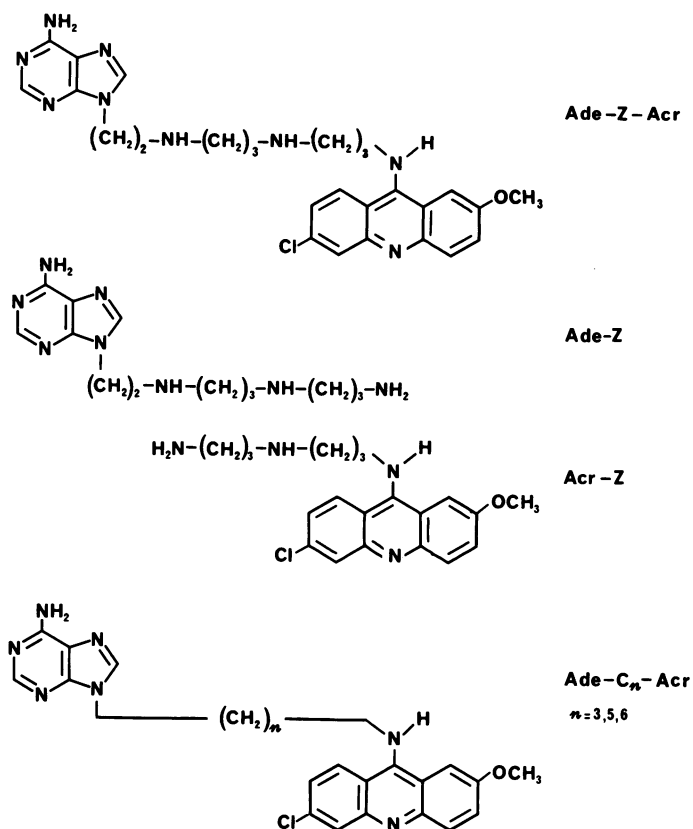

Figure 1 : Structures of the Ade-Z-Acr, Ade-Z, Acr-Z and Ade-C_n-Acr.

in the amount of cleavage of AP-pBR322 DNA (data not shown). The effect of supercoiling was also studied by comparing the cleavage of Ade-Z-Acr on AP-pBR322 and AP-PM2 DNA. The supercoil density of PM2 DNA (approximately - 0.09) is much higher than the supercoil density of pBR322 DNA (approximately - 0.04). The concentration of Ade-Z-Acr for cleavage of both AP-DNAs containing the same number of AP-sites per DNA molecule, however, was identical (data not shown). Therefore, ionic strength and supercoil density do not significantly effect cleavage by Ade-Z-Acr.

Activity of the Ade-Z-Acr is enhanced compared to the activities of the components

The other two experiments displayed in Fig. 3 compare the cleavage of the AP-pBR322 DNA by the Ade-Z-Acr to cleavage by Ade-Z and Z-Acr (Fig. 1).

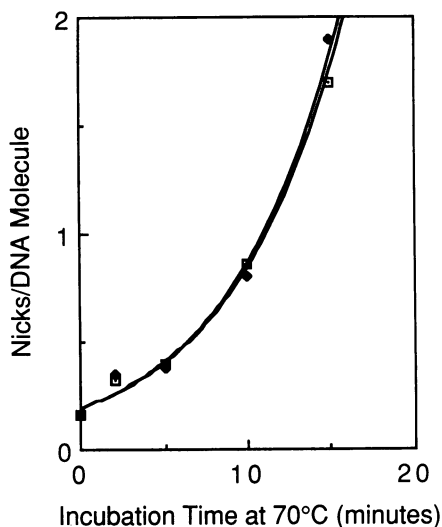

Figure 2 :

Comparison of Ade-Z-Acr and Exonuclease III incision of AP-pBR322 DNA containing different amounts of AP-sites. The number of AP-sites in pBR322 DNA was varied by incubating the pBR322 DNA in 0.1 M sodium acetate buffer, pH 4.8 at 70°C as a function of time. The AP-pBR322 (0.2 μ g) was then subjected to cleavage by Ade-Z-Acr (6.4 μ M) or Exonuclease III (25 units). Agarose gel electrophoresis was used to separate the nicked and supercoiled molecules. The number of incisions was determined as described in Materials and Methods. \square Ade-Z-Acr cleavage, \blacklozenge Exonuclease III cleavage.

These two other molecules, which are the components of the Ade-Z-Acr, show no incising activity in the nanomolar range. Ade-Z-Acr, however, has an activity at least 100 times higher than its components. Additionally, the other molecules investigated which couple the adenine and acridine through aliphatic chains (Ade-C_n-Acr) do not display any enhanced activity to cleave DNA at AP-sites (data not shown). Therefore, the data in the three first sections have shown that Ade-Z-Acr 1) cleaves DNA specifically at AP-sites, 2) is one of the most efficient compounds known for incising DNA at AP-sites, and 3) has a unique composition of an adenine, a 9-aminoacridine and a linker which confers the ability to cleave the DNA at AP-sites.

Determination of the termini following incision by Ade-Z-Acr

In order to determine the nature of the termini formed by the Ade-Z-Acr cleavage at an AP-site, we used the specificity of enzymes for different types of termini. Fig. 4 displays a flow chart which presents the various possibilities of cleavage at AP-sites and methods to discern the type of

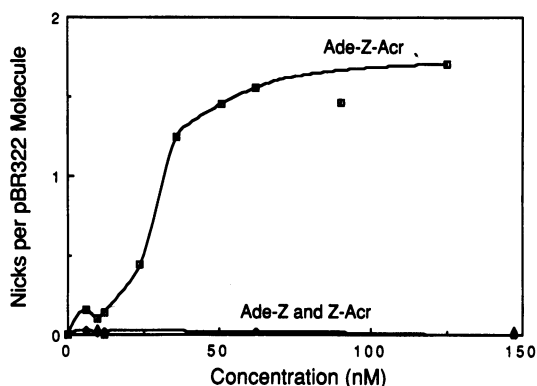

Figure 3 :

Concentration dependence of the incision of AP-pBR322 DNA with Ade-Z-Acr, Ade-Z, and Z-Acr. 0.2 μ g of AP-pBR322 DNA (1.8 nicks/molecule) was incised with increasing amounts of Ade-Z-Acr, Ade-Z, and Z-Acr. The reaction mixture consisted of a total volume of 20 μ l, and was incubated at 37°C for 20 min. Agarose gel electrophoresis was used to separate the nicked and supercoiled molecules. The number of incisions was determined as described in Materials and Methods. \square Ade-Z-Acr, \blacklozenge Ade-Z, and \blacktriangle Z-Acr.

incision observed for drugs or enzymes which cleave at such sites. As control molecules for these experiments we prepared a series of AP-DNAs containing the same number of AP-sites which were cleaved by Exo III and LysTrpLys which also incise DNA at AP-sites. The termini generated by cleaving with these two agents have been well characterized.

If an incision at an AP-site produced a molecule with a 5'OH associated with a base, that site would be a substrate for kinasing using the polynucleotide kinase from bacteriophage T4. However, we were not able to directly kinase the DNA following cleavage by Ade-Z-Acr as shown in Table I. Thus the termini left by the Ade-Z-Acr does not correspond to that of a Class III agent.

The termini generated by Class I agents are characterized by removal of a 5'-phosphate by calf intestine phosphatase, followed by kinasing with the T4 polynucleotide kinase. The results of this experiment given in Table I indicate that the termini generated by Ade-Z-Acr have the same properties as the termini created by the LysTrpLys which is a Class I agent. AP-pBR322 DNA incised by Ade-Z-Acr or LysTrpLys and treated with phosphatase prior to kinase incorporate 32 P at the same level. The AP-pBR322 DNA cleaved by Exo III, however, incorporates the label at the same level as the control.

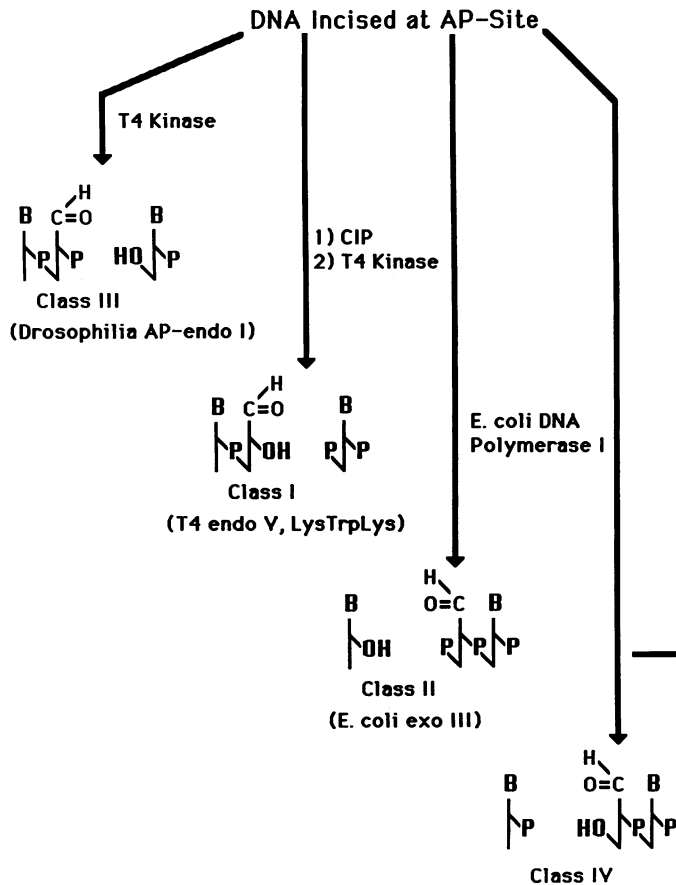

Figure 4 :

Chart indicating the potential cleavage sites by endonucleolytic agents incising DNA at AP-sites and methods for the determination of the class of cleavage (23). Examples of the agents producing the given incision are also indicated for *Drosophila* AP-endonuclease I (24), T4 endo V : T4 UV endonuclease V (25), LysTrpLys (7), and the endonuclease activity of *E. coli* Exonuclease III (20). T4 kinase : 5' polynucleotide kinase from bacteriophage T4, CIP : calf intestine phosphatase.

Priming activity for *E. coli* DNA polymerase I nick translation at termini of incised DNA

To support the previous data, we followed the incorporation of [³H]-dATP into incised AP-DNA by *E. coli* DNA polymerase I. Following incision by the Ade-Z-Acr, the DNA was directly assayed for Class II activity by treatment with DNA polymerase I. The experiment shown in the bottom line of Fig. 5

Table I : Analysis of the termini generated in AP-pBR322 DNA by Ade-Z-Acr

Incising Agent of AP-pBR322 DNA	pmol ³² P Incorporated/μg DNA *	
	DNA Treated with Calf Intestine Phosphatase	DNA not treated with Calf Intestine Phosphatase
Exo III	0.1	0.0
LysTrpLys	1.5	0.1
Ade-Z-Acr	1.9	0.2

* These numbers have been corrected for the control DNA which was the AP-pBR322 DNA which was not treated with an incising agent. The number of AP-site per pBR322 molecule was 1.8. Each of the agents induced the same number of nicks.

indicates that AP-DNAs treated or not treated with Ade-Z-Acr are poor substrates for the DNA polymerase I. Subsequent treatment with bacterial alkaline phosphatase increases only slightly the amount of label incorporated. However, if the Ade-Z-Acr incised AP-DNA is treated with Exonuclease III, the level of incorporation increases to a level comparable to that of cleavage by Exonuclease III alone as seen in Fig. 5. This set of experiments, therefore, confirms the results in the previous section which indicated that the Ade-Z-Acr is a Class I cleavage agent which yields termini consisting of a 3'deoxy-ribose and a 5'phosphate nucleoside.

Ade-Z-Acr does not cleave reduced AP-pBR322 DNA

Since there are Class I agents which are also β -elimination catalysts, we reduced the AP-pBR322 DNA with NaBH₄ and treated the DNA with the Ade-Z-Acr to determine if the aldehyde function was necessary to observe cleavage. The Ade-Z-Acr, however, was not able to cleave the reduced AP-pBR322 DNA (data not shown). In a separate control reaction, the endonuclease activity of Exo III was able to cleave the reduced AP-pBR322 DNA. Thus, both the termini and the inability of the Ade-Z-Acr to cleave the reduced DNA are consistent with the Ade-Z-Acr acting as a β -elimination catalyst.

DISCUSSION

This report has shown that Ade-Z-Acr is an effective agent for incision of DNA containing AP-sites at nanomolar concentrations, and therefore, Ade-Z-

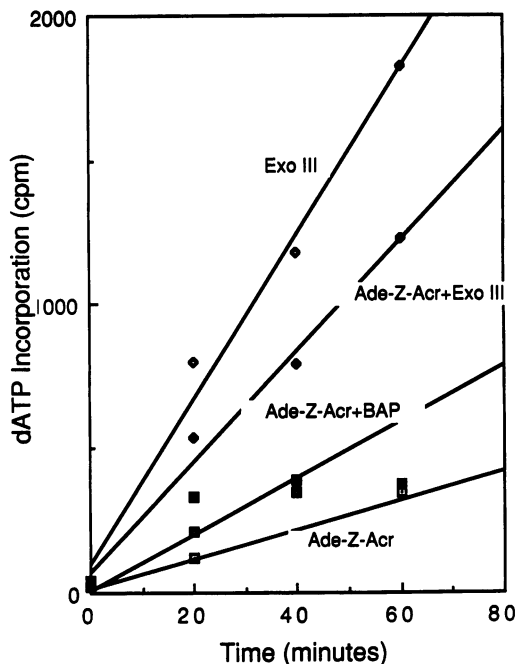

Figure 5 :

Kinetics of priming activity of various nicked AP-pBR322 DNA substrates for *E. coli* DNA polymerase I after incision of AP-pBR322 DNA using Ade-Z-Acr, Exonuclease III, or Ade-Z-Acr incision followed by Exonuclease III treatment. The DNA polymerase I reactions were performed as described in the Materials and Methods. ■ control - AP-pBR322 DNA, □ Ade-Z-Acr incised AP-pBR322 DNA, ▣ Ade-Z-Acr incised AP-pBR322 DNA treated with bacterial alkaline phosphatase, ◆ Ade-Z-Acr incised AP-pBR322 DNA treated with Exonuclease III, and ◇ Exonuclease III incised AP-pBR322 DNA.

Acr represents one of the most active synthetic agents for the cleavage of DNA at AP-sites. The activity of this drug is dependent on the precise design, since the component molecules do not cleave the AP-DNA in the concentrations studied. This cleavage leaves termini which may be kinased at the 5'OH after treatment with a 5'phosphatase. The termini generated following cleavage and the inability of Ade-Z-Acr to cleave reduced AP-DNA suggest that Ade-Z-Acr is a β -elimination catalyst.

Table II compares different agents which cleave DNA at AP-sites. The activities of the 9-aminoellipticine, and the LysTrpLys tripeptide are of approximately the same order of magnitude. The concentration dependence of cleavage by Ade-Z-Acr, however, indicates that this agent is more effective

Table II : Concentration of agents introducing a single nick per DNA molecule at AP-sites

Agent	Concentration* nM	ref.
Ade-Z-Acr	25	this study
LysTrpLys (supercoiled DNA)	1×10^3	7
LysTrpLys (relaxed DNA)	1×10^5	7
9-aminoellipticine	400	10
9-hydroxyellipticine	5×10^4	10
Spermine	1×10^5	7
Spermidine	1×10^7	7

*In each study the quantity of DNA, ionic strength, time, and temperature of incubation vary. The values given therefore are accurate for the best conditions in each study.

at cleaving AP-sites than the 9-aminoellipticine and at least a factor of 1000 greater than the 9-hydroxyellipticine.

The spermine and spermidine values in Table II indicate that although charge is important (the more positively charged spermine is more efficient in cleaving the DNA than spermidine), the charged amine function alone is not responsible for efficient cleavage of DNA at AP-sites.

In addition to the high activity manifested by the Ade-Z-Acr, the conditions for incision by Ade-Z-Acr are similar to that of the 9-aminoellipticine. There is not a strong ionic strength dependence of the Ade-Z-Acr cleavage. In contrast, the LysTrpLys cleavage must be performed at low ionic strength (7,27,28) to facilitate the ionic interaction of the tripeptide with the DNA. Without this interaction, the tripeptide does not cleave at AP-sites. In fact, at peptide concentrations greater than 1×10^{-2} M, the LysTrpLys itself inhibits the incision of DNA as a result of the high ionic strength. This reduced dependence on ionic strength may play a role in the high efficiency of cleavage at AP-sites, since the interaction of the tripeptide LysTrpLys and the intercalator Ade-Z-Acr with the DNA would be expected to be different. The cleavage by LysTrpLys is also supercoil dependent. In addition to the reduced dependence on ionic strength, the cleavage by Ade-Z-Acr is not as sensitive to supercoiling as that of the LysTrpLys. At native

supercoil densities (the supercoil density as isolated from the cell), high concentrations of LysTrpLys (10^{-3} M) must be used to incise AP-pBR322 DNA which has a much lower native supercoil density than AP-PM2 DNA (7). In contrast, there is virtually no difference in the concentration of Ade-Z-Acr needed to incise AP-pBR322 or AP-PM2 DNA.

Two pieces of evidence strongly support β -elimination as the mechanism of Ade-Z-Acr cleavage of DNA at AP-sites. The first evidence is that the termini left by the cleavage are consistent with the cleavage by β -elimination catalysts such as LysTrpLys (7,26). The second piece of evidence supporting this mechanism is that the reduced AP-pBR322 DNA is not a substrate for the Ade-Z-Acr. This agrees with previous reports that the free aldehyde of the deoxyribose interacts with primary amines in the process of β -elimination (29).

This report has introduced a new reagent for probing a specific type of defect in DNA structure. Previously, Dervan coupled a propidium moiety and an Fe-EDTA moiety to create a molecule which cleaves native DNA (30). The molecule presented in this report, Ade-Z-Acr, however has a different target and cleaves DNA at a specific type of lesion : an AP-site. Additionally, the affinity of the Ade-Z-Acr for native DNA is of the same order of magnitude as ethidium bromide (31) which suggests that there is a specificity of cleavage which is not the result of a high binding constant to native DNA. Although the Ade-Z-Acr effects a cleavage specifically at AP-sites using β elimination, the exact mode of action is still speculative. We hope that this molecule will prove useful in the study of AP-sites and AP-endonucleases.

ACKNOWLEDGMENTS

We wish to thank Claudine Lagravère for excellent technical assistance, Serge Boiteux for helpful comments and Ms. Janine Seité for the preparation of the manuscript. J.F.C. was a fellow from MRES. This work was supported by grants from Centre National de la Recherche Scientifique, Institut National de la Santé et de la Recherche Médicale, Association de la Recherche sur le Cancer and Ligue Nationale Française contre le Cancer.

*To whom correspondence should be addressed

REFERENCES

1. Singer, B. and Grunberger, D. *Molecular Biology of Mutagens and Carcinogens*. (1983) Plenum Press. NY.
2. Laval, J. and Laval, F. (1980) *I.A.R.C. Sci. Publ.* 27, 55-73.
3. Lindahl, T. (1982) *Ann. Rev. Biochem.* 51, 61-89.
4. Loeb, L.A. (1985) *Cell* 40, 483-484.
5. Boiteux, S. and Laval, J. (1982) *Biochemistry* 21, 6746-6751.

6. Pierre, J. and Laval, J. (1980) *Biochemistry* **19**, 5024-5029.
7. Pierre, J. and Laval, J. (1981) *J. Biol. Chem.* **256**, 10217-10220.
8. Paoletti, C., Le Pecq, J.-B., Dat-Xuong, N., Juret, P., Garnier, H., Amiel, J.-L. and Rouesse, J. (1980) *Recent Results in Cancer Research* **74**, 107-123.
9. Demarini, D.M., Cros, S., Paoletti, C., Lecointe, P. and Hsieh, W. (1983) *Cancer Res.* **43**, 3544-3552;
10. Malvy, C., Prevost, P., Gansser, C., Viel, C. and Paoletti, C. (1986) *Chem.-Biol. Interact.* **57**, 41-53.
11. Le Pecq, J.B., Xuong, N.D., Gosse, C., Paoletti, C. (1974) *Proc. Natl. Acad. Sci. USA* **71**, 5078-5082.
12. Waring, M.J. (1981) *Ann. Rev. Biochem.* **50**, 159-192.
13. Constant, J.F., Laugaa, P., Roques, B.P. and Lhomme, J. (1987) *Biochemistry*, in press.
14. Pierre, J. and Laval, J. (1980) *Biochemistry* **19**, 5018-5024.
15. Maniatis, T., Fritsch, E.F. and Sambrook, J. (1982) *Molecular Cloning : A Laboratory Manual* Cold Spring Harbor Laboratories.
16. Bolte, J., Demuyne, C., Lhomme, M.F., Lhomme, J., Barbet, J. and Roques, B.P. (1982) *J. Am. Chem. Soc.* **104**, 760-765.
17. Hansen, J.B. and Buchardt, O. (1983) *J. Chem. Soc. Chem. Commun.*, 162-164.
18. Constant, J.F., Carden, B.M. and Lhomme, J. (1985) *J. Heterocyclic Chem.* **22**, 1035-1040.
19. Laval, J. (1977) *Nature* **269**, 829-832.
20. Rogers, S.G. and Weiss, B. (1980) *Methods in Enzymology* **65**, 201-211.
21. Warner, H.R., Demple, B.F., Deutsch, W.A., Kane, C.N. and Linn, S. (1980) *Proc. Natl. Acad. Sci. USA* **77**, 4602-4606.
22. Demple, B. and Linn, S. (1980) *Nature* **287**, 203-208.
23. Linn, S., Demple, B., Mosbaugh, D.W., Warner, H.R. and Deutsch, W.A. (1981) in *Chromosome Damage and Repair* (Seeberg, E. and Kleppe, K., eds.) pp. 97-112, Plenum Press, New York.
24. Spiering, A.L. and Deutsch, W.A. (1986) *J. Biol. Chem.* **261**, 3222-3228.
25. Gordon, L.K. and Haseltine, W.A. (1980) *J. Biol. Chem.* **255**, 12047-12050.
26. Bailly, V. and Verly, W.G. (1987) *Biochem. J.* **242**, 565-572.
27. Behmoaras, T., Touilme, J.J. and Helene, C. (1981) *Nature* **292**, 858-859.
28. Ducker, N.J. and Hart, D.M. (1982) *Biochem. Biophys. Res. Comm.* **105**, 1433-1439.
29. Tamm, C., Shapiro, H., Lipshitz, R. and Chargaff, E. (1953) *J. Biol. Chem.* **203**, 673-688.
30. Dervan, P.B. (1986) *Science* **232**, 464-471.
31. Constant, J.F. Thesis, Université des Sciences et Techniques de Lille, 1986.