Protein complexes formed during the incision reaction catalyzed by the *Escherichia coli* UvrABC endonuclease

Anthony T. Yeung¹⁺, William B. Mattes² and Lawrence Grossman*

Department of Biochemistry, The Johns Hopkins University, School of Hygiene and Public Health, Baltimore, MD 21205, ¹Institute for Cancer Research, Fox Chase Cancer Center, Philadelphia, PA 19111 and ²Laboratory of Molecular Pharmacology, National Cancer Institute, National Institute of Health, Bethesda, MD 20205, USA

Received 20 November 1985; Revised and Accepted 19 February 1986

ABSTRACT

An examination has been made into the nature of the nucleoprotein complexes formed during the incision reaction catalyzed by the *Escherichia coli* UvrABC endonuclease when acting on a pyrimidine dimer-containing fd RF-I DNA species. The complexes of proteins and DNA form in unique stages. The first stage of binding involves an ATP-stimulated interaction of the UvrA protein with duplex DNA containing pyrimidine dimer sites. The UvrB protein significantly stabilizes the UvrA-pyrimidine dimer containing DNA complex which, in turn, provides a foundation for the binding of UvrC to activate the UvrABC endonuclease. The binding of one molecule of UvrC to each UvrAB-damaged DNA complex is needed to catalyze incision in the vicinity of pyrimidine dimer sites. The UvrABC-DNA complex persists after the incision event suggesting that the lack of UvrABC turnover may be linked to other activities in the excision-repair pathway beyond the initial incision reaction.

INTRODUCTION

The *E. coli* *uvrA*, *uvrB*, and *uvrC* genes are required for carrying out the initial incision of pyrimidine dimer-containing DNA (1). The translational products of these genes are proteins of 114,000 (UvrA), 84,000 (UvrB), and 67,000 (UvrC) daltons respectively (2,3) which in the presence of MgATP are necessary for the dual endonucleolytic activity on UV damaged DNA (4,5). One nick occurs seven nucleotides 5' to the pyrimidine dimer and the other nick takes place three or four nucleotides 3' to the same dimer. A pyrimidine dimer-containing fragment of 12 or 13 nucleotides in length is generated (5,6) which is potentially excisable. In the presence of MgATP the UvrA protein binds to UV-damaged DNA (7,5), whereas, the UvrB protein binds DNA only in the presence of the UvrA protein (8). We have previously shown that the binding of the UvrA protein to pyrimidine dimer-containing duplex DNA is enhanced by the UvrB protein and that this enhancement is maximal at equimolar concentrations of UvrA and UvrB proteins (5). In this paper, we describe the properties of the UvrAB-DNA complex with pyrimidine dimer-containing DNA, and demonstrate that UvrC interacts with this complex

physically to form the catalytically active UvrABC endonuclease species. A protein-DNA complex persists following UvrABC endonuclease-catalyzed incision suggesting that components of this protein-substrate DNA complex do not turnover under conditions *in vitro*. The participation of other proteins in initiating turnover of the Uvr proteins implies that this persistent nucleoprotein complex represents a partial repair reaction limiting in essential repair components. The possible roles of this post-incision complex will be discussed.

MATERIALS AND PROCEDURES

The *E. coli* UvrA, UvrB, and UvrC proteins were purified as generally described (5) and their purity, judging from SDS polyacrylamide gel electrophoresis were judged to be greater than 95% pure in the three cases examined. The three Uvr proteins appeared to be 100 percent active judging from their specific activities and their stoichiometric use in the UvrABC endonuclease assay (this work) and in the formation of the UvrAB-nucleoprotein complex (5). The detailed purification procedures will be presented in a forthcoming publication. Protein quantitation was performed by the Bradford dye-binding assay (9) as supplied by Bio-Rad Laboratories. The BA85 nitrocellulose filters were obtained from Schleicher and Schuell. Calf thymus DNA was obtained from Calbiochem and was deproteinized and dialyzed before use.

Preparation of damaged DNA.

A 15 Watt General Electric germicidal lamp was used to irradiate 0.1 mg/ml of fd RF-I DNA at a distance of 45 cm. The dosage at 254 nm was 2 J/M²/sec, producing in 15 seconds about one pyrimidine dimer per covalently-closed circular replicative form I (RF-I) fd DNA molecule.

Preparation of ³H-labeled fd RF-I DNA.

The study of the UvrABC endonuclease has been greatly facilitated by a reliable supply of ³H-labeled fd RF-I DNA of high purity and of a constant specific radioactivity. Bacteriophage fd RF-I DNA was chosen because of the ease of its preparation, and the absence of linker RNA in the RF-I molecule. The following procedure is used to prepare ³H fd RF-I DNA consistently at 150,000 dpm/μg DNA, with a yield of about 300 to 400 μg/l of culture.

E. coli K38 *thy*⁻ cells were maintained by passages in TPA medium (per liter: 0.5 gm NaCl, 8 gm KCl, 1.1 gm NH₄Cl, 12.1 gm Trizma base, 23 mg KH₂PO₄, 0.8 gm Na pyruvate, 2.7 gm salt-free casamino acids, 6.6 ml 12 N HCl to pH 7.4). The medium is autoclaved and the following materials added: 1 ml of

1M CaCl_2 , 1 ml of 0.16 M Na_2SO_4 , 2.8 ml of 1 M MgCl_2 , 2 ml of 20% W/V glucose, 2 ml of 0.1 mg/ml vitamin B1 + 2 $\mu\text{g/ml}$ thymidine. Stationary phase cultures were stored at -20°C in 40% glycerol. A 200 μl aliquot of a K38 glycerol culture stock suspension was inoculated into 40 ml of Luria Broth (per liter: 10 gm yeast extract, 5 gm bactotryptone, 10 gm NaCl, pH 7.6) and shaken at 37°C for about 15 hours. The overnight stationary phase culture was harvested by centrifugation. The cell pellet was resuspended in TPA medium and inoculated into 1 liter of TPA medium containing 2 $\mu\text{g/l}$ of thymidine, in a 2.8 liter triple baffled Fernbach flask. The culture was shaken at 250 rpm at 37°C . After 4 hours, the culture reached approximately 8×10^8 cells/ml. At the time when there was no longer an increase in optical density (about 40 minutes after the end of the log phase growth), the cells were infected with fd phages at a multiplicity of 3 to 5, along with 10 milliCuries of ^3H thymidine (Amersham 25 Ci/mmol). The cells were shaken overnight for about 14 more hours prior to harvesting.

The fd RF-I DNA was prepared as follows: the cell pellet from the overnight infection was resuspended in 30 ml of 10 mM Tris-HCl, 10% sucrose, pH 8.0. Four ml of 0.25M NaEDTA was added to a final concentration of 25 mM, and a freshly prepared solution of lysozyme was added to 1 mg/ml. After 45 minutes on ice, the cells were warmed to 37°C briefly, and an equal volume of a 2 x Hirt buffer (2 M NaCl, 1.2 % SDS, 20 mM Tris-HCl, 10 mM EDTA, pH 7.5) was added at 70°C (10). The mixture was inverted 8 times, and placed at 4°C overnight. The following day, the mixture was centrifuged for 40 minutes at $40,000 \times g$ at 0°C . The pellet was discarded. The supernatant fluid was mixed with 0.8 volume of isopropanol and frozen in a dry ice-ethanol bath for 30 minutes. The frozen tubes were centrifuged for 20 minutes at $27,000 \times g$ to sediment the denatured proteins and the DNA (11). The pellets were extracted with 10 ml of 50mM Tris-HCl, 2mM EDTA pH.7.6 (TE buffer) and centrifuged for 20 minutes at $27,000 \times g$. The pellet arising from the extraction was re-extracted with 10 ml of TE buffer and centrifuged. Thirty grams of CsCl crystals were dissolved in the combined supernatant fractions of the two extractions, and 1 ml of a 10 mg/ml ethidium bromide solution was added. The mixture was centrifuged at $40,000 \times g$ for 20 minutes to pellet the single stranded DNA, RNA and proteins. The supernatant was transferred through a fiberglass filter plug in a syringe into a VT150 ultracentrifuge tube. TE buffer was added to bring the contents of the tube to 50 % W/W in CsCl. After centrifugation for 16-18 hours at 45,000 rpm in a Beckman L5-65 ultracentrifuge, the gradients were fractionated by siphoning from the bottom

of the centrifuge tube. The radioactivity in 2 μ l of each gradient fraction was counted in 4 ml of Aquasol (New England Nuclear) and 300 μ l water. The center of the RF-I peak is typically about 24,000 dpm/2 μ l. The RF-I peak was transferred to a second ultracentrifuge tube. One ml of a 10 mg/ml ethidium bromide solution and 50 % W/W of CsCl in TE buffer was added to volume. The DNA was banded by centrifugation and harvested according to the previously described procedure. The peak of RF-I DNA was collected and the volume noted. The ethidium bromide was removed by 3 extractions with water saturated n-butanol. TE buffer was added to bring the volume to three times the volume prior to the n-butanol extraction followed by 2.4 volumes of isopropanol. The mixture was placed at -20°C overnight and then centrifuged at 6000 rpm in a Sorvall HS-4 rotor for one hour to pellet the fd RF-I DNA. The DNA pellet was washed once with 95 % ethanol and centrifuged the same way for 20 minutes. The final pellet was dried in vacuo and dissolved in 500 μ l of TE buffer. The DNA was further resolved from the RNA by gel filtration chromatography on a column of 15 ml of Bio-Gel A-15 (Bio-Rad) in TE buffer at room temperature. The fd RF-I DNA peak is usually ready for use in assays. The RF-II content of the fd RF-I DNA is about 3-7% as judged by the denaturation-renaturation assay. The DNA is free of both RNA and protein. The DNA can be rebanded in CsCl gradients each month to remove the RF-II molecules that are slowly formed during storage.

UvrABC endonuclease assay.

The UvrABC endonucleolytic activity measures the conversion of a duplex RF-I DNA to the RF-II DNA species which upon denaturation generates single-stranded species which under appropriate ionic strength conditions bind to nitrocellulose filters (5,12). The number of pyrimidine dimers in each fd DNA molecule averaged between 1 and 6 according to the needs of the experiments. The 140- μ l reaction mixture consisted of 85 mM KCl, 40 mM potassium morpholinopropanesulfonate (MOPS) at pH 7.6, 1 mM NaEDTA, 1 mM dithiothreitol, 15 mM MgSO₄, 2 mM ATP, 39 fmol (0.16 μ g) of ³H-labeled fd RF-I DNA, 490 fmol of UvrA protein, 535 fmol of UvrB protein, and 516 fmol of UvrC protein. The mixture is incubated at 37°C and then subjected to denaturation and renaturation as described (12). A slight molar excess of the three Uvr proteins over the concentration of pyrimidine dimers is required since the Uvr AB proteins complex with undamaged regions of the DNA and are all consumed stoichiometrically in these in vitro reactions (this work). Furthermore the levels of the DNA substrate are maintained at fairly low concentrations in the reaction mixtures.

Protein-DNA filter binding assay.

The amount of fd duplex DNA bound to UvrA, UvrB and UvrC proteins, as nucleoprotein complexes, was measured by the nitrocellulose filter binding assay (13). The nucleoprotein complexes were formed by incubating the UvrA, UvrB and UvrC proteins with the fd RF-I DNA under conditions identical to those described for the UV-endonuclease assay. After the incubation at 37°C, in the presence of MgATP to form the nucleoprotein complexes, the reactions were terminated by the addition of one of the following: a) 5 ml of ice cold assay buffer; b) 16 µg of UV irradiated calf thymus DNA containing approximately one pyrimidine dimer per 1000 base-pairs, in 5 µl, incubated for 5 minutes at 37°C and then quenched with 5ml of cold 2 x SSC (0.3 M NaCl, 0.03 M trisodium citrate); c) 5 ml of cold 2 x SSC. The fd RF-I DNA molecules bound to protein were then collected by trapping onto a BA85 nitrocellulose filter.

RESULTS AND DISCUSSIONStoichiometric use of UvrC in the Nicking of pyrimidine dimer sites.

Equimolar levels of UvrA, UvrB and UvrC proteins were previously used in the UV endonuclease assay in order to obtain maximum rates of incision at pyrimidine dimer sites (5). However, as little as 10 fmol of UvrC can be used with 500 fmol of each of the UvrA and UvrB proteins in an incision assay designed to measure the stoichiometry of UvrC versus nicked pyrimidine dimer

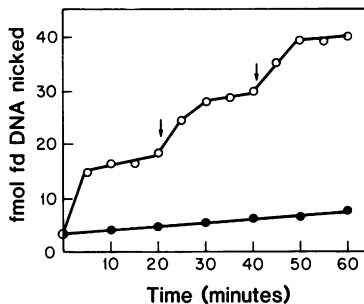

Figure. 1. Stoichiometric reaction of UvrC in the UvrABC endonuclease DNA nicking reaction. The nicking of the pyrimidine dimer sites was followed by scoring for the nicking of the RF-I form of the fd RF-I DNA (open circles). Each assay contained 50 fmol of fd RF-I DNA molecules with an average of 6 pyrimidine dimers each, 490 fmol of UvrA protein and 535 fmol of UvrB protein in a volume of 140 µl. 1 unit of UvrC (10 fmol) was added to initiate the incision reaction at 0 time. At the times indicated by arrows, an additional unit of UvrC protein was added to each reaction to allow the incision to continue. Solid circles represent background nicking of unirradiated fd RF-I DNA.

sites. In the experiment presented in Fig. 1, when UvrA and UvrB proteins are in excess, the addition of each unit of UvrC (10 fmol) resulted in the nicking of 9.8 fmol of fd molecules. This stepwise increase in nicking suggests that UvrC is used stoichiometrically in the nicking of pyrimidine dimer sites. It can also be inferred that UvrC is part of the stable post-incision complex. Although 500 fmol of UvrA and UvrB proteins provide a demonstrable rate of incision in the incision assays, the actual number of UvrA and UvrB protein molecules taking part in the nicking of each pyrimidine dimer has not been determined.

That the UvrA and UvrB proteins used in our studies function stoichiometrically (5) and that UvrC also functions stoichiometrically in the incision of pyrimidine dimer sites indicates that there are no detectable inactive UvrA, UvrB and UvrC protein molecules in our preparations. This is an important consideration in a study of stable protein complexes of partial repair reactions because it is reasonable to expect that the presence of partially inactive Uvr proteins in the reaction can also form stable nucleoprotein complexes.

Binding of UvrA, UvrB and UvrC proteins to fd RF-I DNA during incision.

As a prerequisite to using filter-binding experiments, it was originally observed that UvrA and UvrB proteins, already washed onto the nitrocellulose filter, were unable to bind any additional fd RF-I DNA (data not shown). The effects of ATP, UV damage and combinations of UvrA, UvrB and UvrC proteins in

TABLE I
BINDING OF DNA TO Uvr PROTEINS

		Uvr PROTEINS ADDED						
ATP	UV	A	B	C	AB	BC	CA	ABC
+	+	12.2	0.4	0.7	14.8	0.9	11.8	14.1
+	-	7.0	0.5	0.6	8.6	0.6	8.9	7.8
-	+	4.7	0.3	0.0	5.2	0.4	4.8	4.9

The binding of UvrA, UvrB and UvrC protein combinations to DNA was assessed with the protein-DNA filter binding assay. The fd RF-I DNA RF-I was either undamaged or contained an average of 2 pyrimidine dimers per molecule. The assay contained 40 fmol of fd and 500 fmol each of the respective Uvr proteins. The mixture of proteins and DNA was incubated in the nicking assay buffer at 37°C for 20 minutes in the presence or absence of ATP. The assay was terminated by the addition of 5 ml of assay buffer lacking ATP, at 4°C, and passed through a BA85 nitrocellulose filter at a rate of 10 ml per minute. The filters were washed with 5 ml of the same buffer, dried under a heat lamp, and the level of radioactivity determined. The values presented in this table represent the number of fmoles of fd RF DNA bound to the nitrocellulose filters.

the formation of protein-DNA complex were tested by the protein-DNA filter-binding assay. The results are presented in Table I. The binding of UvrA protein to fd RF-I DNA was enhanced by the presence of ATP and UV damaged DNA, but the binding was not strictly UV-dependent or ATP-dependent. The extent of fd RF-I DNA binding to protein was uniformly similar in those combinations involving UvrA, such as UvrAB, UvrAC and UvrABC proteins although binding was slightly enhanced in those combinations containing in addition the UvrB protein. The increase in damage-dependent binding due to UvrB protein became more obvious in later experiments in which the amount of damage was increased from 2 dimers/fd RF-I DNA in this experiment to six dimers/fd RF-I DNA.

In the experiments in Table I, the binding reactions were terminated by diluting the reaction mixture with 5 ml of cold reaction buffer. Under these conditions, the binding of UvrA protein to fd RF-I DNA is preserved and provides a perspective of the spectrum of nucleoprotein complexes that coexist during a UvrABC endonuclease reaction. Since UvrABC incision sites are 13 bases apart the presence of two pyrimidine dimers in a DNA molecule will affect 26 base pairs or 0.4 % of the total number of base pairs in a fd RF-I DNA molecule.

Conditions for resolving different Uvr nucleoprotein complexes.

The relative contributions of UvrB and UvrC molecules to the binding of UvrA protein to damaged and undamaged fd RF-I DNA are summarized in Table II in studies dealing with the decay of different nucleoprotein complexes. After the nucleoprotein complexes were formed at 37°C in the presence of MgATP buffer and various combinations of UvrA, UvrB, and UvrC proteins, the binding reaction was terminated by dilution into various buffers. Collection of the nucleoprotein complexes onto nitrocellulose filters was performed at several time points after the dilution step. The UvrC protein did not confer additional stability to the complexes of UvrA protein with damaged or undamaged DNA. However, the stabilities of UvrAB protein-damaged-DNA complex in the presence of MgATP at 37°C or in chelator-buffers at 4°C are striking. The dilution of the binding reaction with 4°C in 2 x SSC allowed for the measurement of that amount of UvrAB-damaged DNA nucleoprotein complexes formed under different experimental conditions. The UvrAB complex with damaged DNA was also stable in 1 M KCl, 50 mM EDTA at 4°C (data not shown). The formation of the UvrAB complex with DNA was MgATP-dependent with a K_m for Mg^{2+} of about 0.1 mM (data not shown). The maximum formation of the UvrAB complex with damaged DNA occurred when the UvrA and UvrB proteins were in equimolar

TABLE II
RESIDENCE TIMES OF Uvr PROTEINS

Uvr proteins	Treatment of fd DNA	Dilution buffer	Protein-DNA Complex half-life decay time (Temp °C)	Complex decay time (Time)
UvrA	+UV/-UV	chelator	4 or 37	<5 sec.
UvrA+C	+UV/-UV	chelator	4	<5 sec.
UvrA+B	-UV	chelator	4	<5 sec.
UvrA+B	+UV	chelator	4 21 37	55 min. 13 min. <1 min.
UvrA+B	+UV	MgATP	37	42 min.
UvrA+B+C	+UV	MgATP	37	>40 min.
UvrA+B+C	+UV	chelator	37	10 min.

UvrA, UvrB and UvrC proteins were incubated with fd RF-I DNA using conditions described in the legend to Table I except the damaged fd DNA contains an average of 6 pyrimidine dimers per fd molecule. The binding reaction was terminated by dilution of the reaction mixture with either 5 ml of reaction buffer containing MgATP, or 5 ml of chelator buffer (2 x SSC, or assay buffer containing 50 mM EDTA) and incubated at the temperatures indicated in the table. The stability of the nucleoprotein complexes are expressed as the half-lives of decay of the amount of radioactive fd DNA retained by the nitrocellulose filter.

proportions (5), implying that UvrA and UvrB proteins can interact before they are bound to the damaged site on DNA.

Effect of the pyrimidine dimer content on UvrAB binding.

The non-specific binding of the UvrA and UvrB proteins to undamaged DNA increases with increasing concentrations of the UvrA and UvrB proteins (Figure 2, panel B). The effectiveness of the chelator-buffer wash in reversing the binding of UvrA and UvrB to the undamaged fd RF-I DNA molecule is seen in Figure 2, panel B. It seems likely that the binding of UvrA and UvrB protein to the fd RF-I DNA molecule containing pyrimidine dimers will be a combination of the binding to regions of the DNA influenced by the damage and to regions of the DNA that are not measurably influenced by the presence of pyrimidine dimers. Binding to the latter region should represent the amount of binding decreased by the chelator-buffer wash, while the amount of binding stable to these conditions should reflect binding to damaged sites. The exact region responsible for resistance to the chelator-buffer has as yet not been determined. For the purposes of interpreting later experiments, it should be noted that at any given concentration of UvrA and UvrB proteins and given

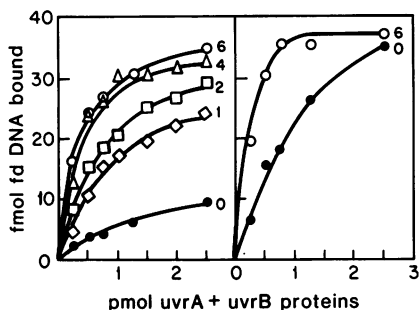

Figure 2. Binding of UvrAB to fd RF-I DNA under different conditions. The conditions for the binding reaction were the same as those described for the experiments in Table I. The number of pyrimidine dimers per fd molecule is indicated. The dilution buffers used to stop the binding reaction was 2 x SSC at 4°C in panel A, and 4°C binding-buffer in panel B. The amount of Uvr protein per assay is 0.5 pmol each in a 140 μ l reaction volume.

amounts of pyrimidine dimers in a DNA population only a certain percentage of all the fd RF-I DNA molecules that are bound to the UvrA and UvrB proteins during the binding reaction actually have the UvrA and UvrB proteins residing on the pyrimidine dimers to form the more stable UvrAB-nucleoprotein complex. Only the pyrimidine dimer-bound UvrA and UvrB molecules are resistant to dilution and competition as well as being receptive to UvrC binding for endonuclease activation.

UvrAB-nucleoprotein complex as a precursor of the UvrABC-endonuclease complex.

If the UvrAB-nucleoprotein complex is a precursor to the UvrABC endonuclease complex, it can be expected that UvrC should be able to bind to this complex as a prerequisite to UvrABC catalysis. This was found to be the case (Fig 3). The addition of competing DNA (100-fold excess of unlabeled UV-irradiated calf thymus DNA) to the reaction mixture before the addition of UvrA, UvrB and UvrC proteins resulted in the quantitative inhibition of the UvrABC endonuclease presumably because the UvrA and UvrB proteins were diverted to the competing DNA. The inhibition was effective when only the UvrA protein was allowed to interact with the fd RF-I DNA before the addition of the competing DNA, indicating that nucleoprotein complexes of UvrA protein with the pyrimidine dimer sites are of low affinity. When, however, the UvrAB protein-damaged DNA complex was allowed to form prior to the addition of the competing DNA, the subsequent addition of UvrC was able to bring about rapid incision at levels comparable to the amount of UvrAB-damaged-DNA complex that was formed under the conditions of that experiment. Further incision of those

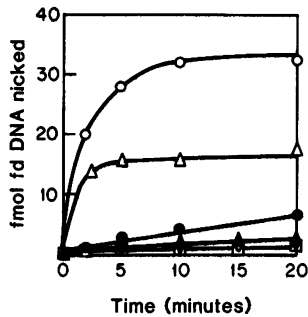

Figure 3. The preformed UvrAB complex binds UvrC to form the UvrABC endonuclease. The ability to nick the fd RF-I DNA in a UV-specific manner was scored in this experiment. Open symbols, DNA irradiated to produce an average of 6 pyrimidine dimers per fd molecule; solid symbols, undamaged fd DNA. Each of the reaction mixtures contained 0.5 pmol of UvrA, UvrB and UvrC; circles, normal nicking by UvrABC endonuclease without other treatment. Squares, inhibition of the UvrABC endonuclease by the presence of competing DNA (100-fold excess of UV irradiated calf thymus DNA containing 1 dimer/1000 base-pairs). Triangles, UvrA and UvrB proteins were allowed to form nucleoprotein complexes at damaged sites in DNA for 10 minutes at 37°C before the addition of the competing DNA. The subsequent addition of UvrC resulted in nicking of the fd RF-I DNA. Inverted triangles, only UvrA protein was used to form nucleoprotein complexes with the pyrimidine dimer-containing fd RF-I DNA before the addition of the competing DNA; subsequent addition of UvrB and UvrC molecules did not result in nicking of the fd RF-I DNA.

dimer sites uncomplexed to UvrA and UvrB was inhibited by the presence of the competing DNA. It should be noted that the ability of UvrC to recognize the UvrAB protein-DNA complex was not affected by the presence of the competing DNA, indicating that the binding of UvrC to the preformed UvrAB protein-DNA complex was direct without UvrC first binding to the DNA. The rates of formation of the stable UvrAB-damaged DNA complex were the same as the rates of incision of the UvrABC endonuclease when identical concentrations of Uvr proteins as well as same number of pyrimidine dimers per fd RF-I DNA molecule were used (data not shown). The formation of the stable UvrAB pyrimidine dimer-containing nucleoprotein complex is likely, therefore, to be the rate-limiting step in the UvrABC endonuclease incision reaction.

Another approach was taken to test the association of UvrC with the UvrAB-DNA complex. While testing for the activity of UvrABC endonuclease on DNA damaged by acetophenone photosensitization (14), it was observed that the UvrABC endonuclease was inactivated by the trace amounts of silver ions used to stabilize the DNA during black-light irradiation. Similar concentrations of Ag⁺ had no effect on the dimer DNA-glycosylase of *Micrococcus luteus*

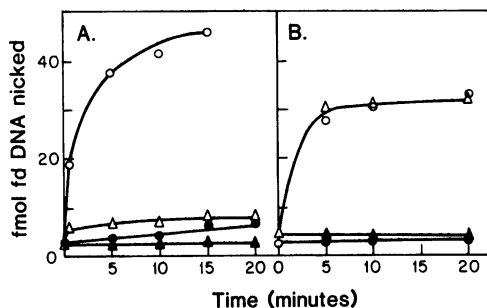

Figure 4. Inactivation of UvrC by Ag^+ in the absence of preformed UvrAB protein-pyrimidine dimer complex. The conditions for the UvrABC endonuclease nicking assay as well as for the protein-DNA complex formation were identical to those used in the experiments in Fig 2. Panel A; open circles, normal nicking of damaged fd RF-I DNA; solid circles, undamaged fd RF-I DNA; open triangles, UvrABC endonuclease activity in the presence of $10 \mu\text{M Ag}^+$; solid triangles, control nicking of undamaged fd RF-I DNA in the presence of $10 \mu\text{M Ag}^+$. Panel B; open circles, UvrAB protein-DNA complex was allowed to form at 37°C for 20 minutes before a 100-fold excess of UV irradiated calf thymus DNA was added. The incubation was continued for 5 minutes and then UvrC was added to nick the preformed UvrAB protein-DNA complexes; solid circles represent controls with undamaged fd RF-I DNA; open triangles, UvrAB protein-DNA complex was allowed to form at 37°C for 20 minutes before the reaction was adjusted to $10 \mu\text{M Ag}^+$. After 5 minutes at 37°C , UvrC was added to score for the nicking of the preformed UvrAB protein-DNA complex. Note that the nicking of the fd DNA did not continue beyond the amount allowed by the preformed UvrAB-pyrimidine dimer complex. Solid triangles represent controls with undamaged fd RF-I DNA in the Ag^+ experiment.

(data not shown). When a mixture of UvrA, UvrB and UvrC proteins is pre-incubated for two minutes at 37°C with $10 \mu\text{M Ag}^+$, the UvrABC endonuclease was inactivated within seconds (Fig 4A). Brief incubations of UvrC with $10 \mu\text{M Ag}^+$ prior to its addition to incubation mixtures containing UvrA and UvrB results in complete inactivation of UvrC (Table III). The stability and the assembly of either UvrA or the UvrAB protein-damaged-nucleoprotein complex was unaffected by the presence of $10 \mu\text{M Ag}^+$ (Figure 5). The inhibition of the Ag^+ on UvrABC endonuclease appears to be specific for UvrC. The ability of UvrC to bind to the preformed UvrAB-damaged-DNA complex to activate the UvrABC endonuclease was unaffected by the presence of $10 \mu\text{M Ag}^+$ (Fig 4B) presumably because the binding of UvrC to a preformed UvrAB-DNA complex is faster than its reactivity with Ag^+ . The amount of UvrABC endonuclease activity was identical to the control experiment in which further formation of UvrAB complexes with pyrimidine dimers was inhibited by the addition of competing DNA. It appears that Ag^+ is able to inactivate those UvrC molecules

Table III
Inactivation of the UvrC Protein by Silver Ions

	DNA+UV	DNA-UV
0 Ag ⁺	51.7	3.75
10 μM Ag ⁺	0.9	1.0

UvrC protein at a concentration of 516 fmol/0.4 μl was adjusted to 10 μM in AgNO₃ and incubated for 2 minutes at room temperature. 516 fmol of this treated UvrC protein, diluted in 5 μl of assay buffer, was added to a 135 μl volume of assay buffer containing 60 fmol of ³H fd RF-I DNA (average of 3 pyrimidine dimers /molecule), 490 fmol of UvrA and 535 fmol of UvrB. The mixture is incubated for 20 minutes at 37°C. Control reactions were performed with DNA that has no UV damage, or with UvrC protein that has not been exposed to Ag⁺. The values in the table represent the number of fmoles of the fd RF-1 DNA nicked by the UvrABC endonuclease.

free in solution. Perhaps the conformation assumed by UvrC after the formation of the UvrABC endonuclease complex protected UvrC from inactivation by Ag⁺. It is concluded from these findings that there is a physical interaction between UvrC and the UvrAB-DNA complex immediately before the activation of the UvrABC endonuclease activity. In this experiment, no attempt was made to remove UvrAB complexes which were formed with the undamaged parts of the fd RF-I DNA. The presence of Ag⁺ allows no further incision events to occur subsequent to the nicking of the preformed UvrAB damaged-DNA complexes. The rapid cessation of the incision reaction indicated that any binding of

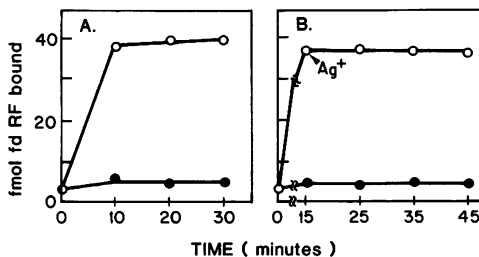

Figure 5. Protein-DNA filter binding assays to evaluate the effects of Ag⁺ on the formation and the stability of the UvrAB-nucleoprotein complex. Panel A: open circles, about 500 fmol of UvrA and UvrB proteins were incubated at 37°C with 60 fmol of fd RF-I DNA in a 40 μl reaction in the presence of 10 μM Ag⁺. The solid circles represent control reactions with undamaged fd RF-I DNA; panel B: as in Panel A, except the Ag⁺ was added only after the binding reaction had proceeded for 15 minutes. Following the addition of the Ag⁺, the incubation was continued for another 30 minutes to test the effect of Ag⁺ on the stability of this preformed UvrAB-pyrimidine dimer containing nucleoprotein complex.

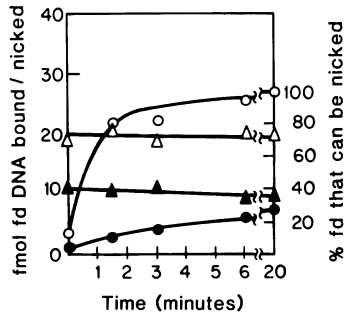

Figure 6. Formation of the post-incision protein-DNA complex. The UV-irradiated fd RF-I DNA (open symbols) in this experiment contained an average of one pyrimidine dimer per fd molecule. The data recorded on the right vertical axis indicates that only 67% of the 40 fmol of fd molecules in an assay will contain at least one pyrimidine dimer. Circles represent nicking of the fd RF-I DNA. Triangles represent binding of the protein-DNA complexes to the nitrocellulose filter. The solid symbols indicate control experiments using undamaged fd RF-I DNA. 2.5 pmol of UvrA, UvrB and UvrC each (five times the amount in a regular nicking assay) was used in a 140 μ l assay volume.

UvrC to UvrAB complexes that were formed on undamaged regions of the DNA do not lead to productive incision events.

Formation of post-incision Uvr-protein-incised nucleoprotein complexes.

To measure binding of the UvrABC endonuclease to an incised pyrimidine dimer site on a fd molecule, it is necessary to rule out the presence of other unincised dimer sites on the same fd molecule since such remaining dimer sites will form stable nucleoprotein complexes. Alternatively, artificial conditions must be employed in which the post-incision protein-DNA complex can be detected and distinguished from the UvrAB complex formed at unincised pyrimidine dimer sites. In the experiment presented in Fig 6, the DNA substrate contained an average of one pyrimidine dimer per fd molecule. The nicking of the DNA was permitted to proceed for a period 20 times longer than the time necessary for nicking one dimer on each fd molecule, thereby, minimizing the influence of unincised dimer sites. It was observed that the UV-specific binding remained after this extended period of UvrABC endonuclease action suggesting that a protein-DNA complex persisted. The binding to undamaged DNA was higher in this experiment because the concentration of the UvrA, UvrB and UvrC proteins was increased 5-fold (2.5 pmol/140 μ l reaction) in order to obtain sufficient damage-specific binding to DNA molecules with pyrimidine dimer concentrations of one dimer per fd molecule. It is also possible to demonstrate the presence of the post-incision complex under

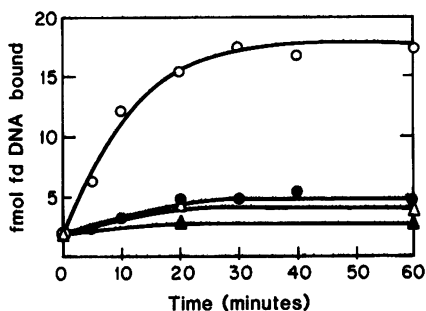

Figure 7. Accumulation of post-incision protein-DNA complex. The UV irradiated fd RF-I DNA (open symbols) in this experiment contained an average of six pyrimidine dimers per fd molecule. The amount of UvrA, UvrB and UvrC proteins used in these experiments was 0.5 pmol each. The fd RF-I DNA was treated with the UvrABC endonuclease (circles), or only UvrA and UvrB proteins (triangles), for 0-60 minutes (x-axis) at 37°C. At the indicated time points, the reaction was adjusted to 50 mM EDTA. After 5 minutes at 37°C, the reaction was terminated by dilution with 5 ml of cold 2xSSC and the nucleoprotein complexes were collected by passing the mixture through a nitrocellulose filter.

conditions that would lower the non UV-specific background binding. In the experiment presented in Fig 7, an average of six pyrimidine dimers per fd molecule was used. The UvrABC protein concentration was 500 fmol/ 140 μ l, thus the binding to undamaged DNA was low. The UvrAB-DNA complex has a half-life of less than one minute at 37°C in the presence of excess chelators (Table II and Fig 7). The post-incision complex would be detectable if it is significantly more stable under the same conditions. Thus, when the UvrABC endonuclease was allowed to incise the pyrimidine dimer containing fd RF-I DNA, a partially stable complex persisted in the presence of 50mM EDTA at 37°C. The appearance of this complex was dependent on the presence of UvrC in addition to the UvrA and UvrB proteins. The post-incision complex was not completely stable in chelator-containing buffer at 37°C because its accumulation was significantly slower and less than the nicking of the pyrimidine dimer containing DNA. Its half-life of decay in this chelator buffer at 37°C was estimated to be about 20 minutes. It is concluded that the Uvr protein-DNA complex persisted after the incision event.

Model of the interaction of the UvrABC endonuclease during the incision reaction.

A current working model for the mechanism of nucleotide excision repair is illustrated in Fig 8. In the presence of MgATP, the UvrA protein binds to duplex DNA and translocates on the DNA for short distances in which the energy

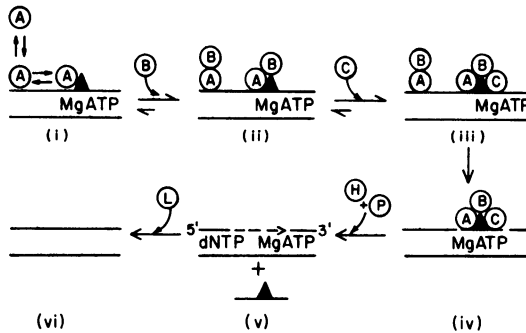

Figure 8. Model for the interactions of the proteins in nucleotide excision repair in *E. coli*. The double lines represent duplex DNA. The DNA lesion (e.g.: pyrimidine dimer) is drawn as a triangle. (i) UvrA protein (A) binds to the undamaged DNA as well as the damaged region. (ii) In the presence of MgATP, UvrA and UvrB (B) form a tight protein-DNA complex with the damaged region. The UvrAB complex bound to the undamaged DNA has a much lower affinity than one bound to the damaged regions. (iii) UvrC (C) is able to bind to a UvrAB complex that is on the DNA-damage region and activate the UvrABC-endonuclease. (iv) After the DNA strand containing the DNA damage has been nicked on both sides of the damage, a certain Uvr-protein-DNA complex remained. The 13 base fragment generated by the dual incision remains bound to the DNA. (v) DNA helicase II (H) and DNA polymerase I (P) interact with the post-incision protein-DNA complex, and, the post-incision complex, as well as the 13 base fragment containing the DNA damage, are displaced (18). (vi) The DNA gap is then filled by the coordinated action of DNA polymerase I and DNA helicase II. The continuity of the DNA strand is restored by DNA ligase (L).

of ATP hydrolysis may be used in part to locate a damaged site to which it binds. This affinity is further enhanced by the presence of the UvrB protein. When the number of UvrB protein molecules present is much larger than the number of UvrA molecules that are bound to pyrimidine dimer sites, the UvrB protein may also bind to those UvrA protein molecules which are not yet bound to pyrimidine dimer sites. However, no significant gain in protein-DNA complex stability is achieved over the binding of the UvrA protein alone to DNA. The UvrC protein binds directly to the UvrAB-pyrimidine dimer-DNA complex to activate the UvrABC incision activity which nicks the pyrimidine dimer-containing DNA strand on both sides of the pyrimidine dimer. Although a single molecule of UvrC protein is sufficient to produce one incision at a UvrAB-pyrimidine dimer complex, the stoichiometry of the UvrABC proteins within the protein-DNA complex has not been determined. The 12 or 13 base pyrimidine dimer-containing single-stranded fragment is enzymatically released at a later stage (18). The simultaneous presence of the DNA helicase II (UvrD protein)

and DNA polymerase I is necessary for the simultaneous fragment release and gap filling process (18). The presence of DNA ligase leads to the restoration of the continuity of the incised DNA strands. The persistence of the UvrABC proteins after incision may stabilize the potentially excisable fragment at the expense of limiting the turnover of the three incising proteins until other enzyme activities of excision repair such as DNA helicase II (UvrD protein, 15,16) and DNA polymerase I (17) becomes available (18). The coordinated nature of the entire excision process may help to preserve the integrity of damaged DNA during the process of repair.

ACKNOWLEDGEMENTS

These studies were supported by grants from the National Institutes of Health (GM-22846) and the Department of Energy (EX-76-S-02-2814) to L.G.

+To whom correspondence should be addressed

*To whom reprint requests should be addressed

REFERENCES

1. Howard-Flanders, P., Boyce, R.P., and Theriot, L. (1966) *Genetics* **53**, 1119-1136.
2. Yoakum G.H. and Grossman, L. (1981) *Nature* **272**, 171-173.
3. Kacinski, B.M. and Rupp, W.D. (1981) *Nucleic Acids Res.* **9**, 4495-4508.
4. Seeberg, E. (1978) *Proc. Nat. Acad. Sci. USA.* **75**, 2569-2573.
5. Yeung, A.T., Mattes, W.B., Oh, E.Y., and Grossman, L. (1983) *Proc. Nat. Acad. Sci. USA* **80**, 6157-6161.
6. Sancar, A., and Rupp, W.D. (1983) *Cell* **33**, 249-260.
7. Seeberg, E. and Steinum, A.L. (1982) *Proc. Nat. Acad. Sci. USA.* **79**, 988-992.
8. Kacinski, B.M., and Rupp, W.D. (1981) *Nature* **294**, 480-481.
9. Bradford, M. (1976) *Anal. Biochem.* **72**, 248-254.
10. Hirt, B. (1967) *J. Mol. Biol.* **26**, 265-369.
11. Cohen, R.J. and Crothers, D.M. (1970) *Biochem.* **9**, 2533-2539.
12. Riazuddin, S. and Grossman, L. (1977) *J. Biol. Chem.* **252**, 6280-6286.
13. Riggs, A.D., Bourgeois, S., Newby, R.F. and Cohen, M. (1968) *J. Mol. Biol.* **34**, 365-368.
14. Rahn, R.O., Landry, L.C. and Carrier, W.C. (1974) *Photochem. Photobiol.* **19**, 75-78.
15. Kushner, S.R., Maples, V.F., Easton, A., Farrance, I., and Peramachi, P. (1983) In *Cellular Responses to DNA Damage*, eds. Friedberg, E.C. and Bridges, B.A. Alan Liss Inc. N.Y. pp 153-159.
16. Kumura, Oeda, K., Akiyama, M., Horiuchi, T. and Sekiguchi, M. In *Cellular Responses to DNA Damage*, eds. Friedberg, E.C. and Bridges, B.A. Alan Liss Inc. N.Y. pp 51-62.
17. Setlow, P., Brutlag, D., and Kornberg, A. (1972) *J. Biol. Chem.* **247**, 224-231.
18. Caron, P.R., Kushner, S.R. and Grossman, L. (1985) *Proc. Natl. Acad. Sci. USA* **82**, 4925-4929.