

Original Article

Multi-Walled Carbon Nanotube (MWCNT) Dispersion and Aerosolization with Hot Water Atomization without Addition of Any Surfactant

Kang-ho AHN¹, Sun-Man KIM¹ and Il Je YU²¹Department of Mechanical Engineering, Hanyang University, ²Toxicological Research Center, Hoseo University, Asan, Korea

Objectives: Carbon nanotubes are an important new class of technological materials that have numerous novel and useful properties. Multi-walled carbon nanotubes (MWCNTs), which is a nanomaterial, is now in mass production because of its excellent mechanical and electrical properties. Although MWCNTs appear to have great industrial and medical potential, there is little information regarding their toxicological effects on researchers and workers who could be exposed to them by inhalation during the handling of MWCNTs.

Methods: The generation of an untangled MWCNT aerosol with a consistent concentration without using surfactants that was designed to be tested in *in vivo* inhalation toxicity testing was attempted. To do this, MWCNTs were dispersed in deionized water without the addition of any surfactant. To facilitate the dispersion of MWCNTs in deionized water, the water was heated to 40°C, 60°C, and 80°C depending on the sample with ultrasonic sonication. Then the dispersed MWCNTs were atomized to generate the MWCNT aerosol. After aerosolization of the MWCNTs, the shapes of the NTs were examined by transmission electron microscopy.

Results: The aerosolized MWCNTs exhibited an untangled shape and the MWCNT generation rate was about 50 mg/m³.

Conclusion: Our method provided sufficient concentration and dispersion of MWCNTs to be used for inhalation toxicity testing.

Key Words: Multi-walled carbon nanotube, Aerosol generation, Ultrasonic dispersion, Inhalation, Surfactant

Introduction

In recent years, engineered nanoparticles have been synthesized and mass produced because of their exceptional physical, chemical, optical, magnetic, and electrical properties compared to bulk material. The application areas of nano-materials is ex-

panding widely from consumer goods to medical applications [1]. Multi-walled carbon nanotubes (MWCNTs), which is one type of nanomaterial, is now in mass production because of its excellent mechanical and electrical properties. Some nanotubes have already been used in medicine for cancer treatment [2].

During the research, production, and handling of MWCNTs, researchers and workers may be directly exposed to this material [3]. Health effects of carbon nanotubes (CNTs) have been studied by many researchers [4,5]. One paper reported on the adverse effects on human pulmonary cells by MWCNTs [5]. To verify the health effects of MWCNTs when inhaled, a good MWCNT generation technique or instrument is needed. Myojo et al. generated MWCNTs with a combination of a rotating brush and fluidized bed [6]. They found their system was good enough to generate and control their MWCNT aerosol. Baron et al. used a vortex shaker with bronze beads to form a fluidized bed for generation of single-walled carbon nano-tubes

Received: September 14, 2010, **Accepted:** January 4, 2011

Correspondence to: Kang-ho AHN

Department of Mechanical Engineering, Hanyang University
1271, Sa 3-dong, Sangnok-gu, Ansan 425-791, Korea

Tel: +82-31-400-5284, **Fax:** +82-31-436-8184

E-mail: kxanh@hanyang.ac.kr

Correspondence to: Il Je YU

Toxicological Research Center, Hoseo University
165, Sechul-ri, Baebang-myeon, Asan 336-795, Korea

Tel: +82-42-540-9630, **Fax:** +82-42-540-9846

E-mail: u1670916@chollian.net

(SWCNTs) [7]. They found that the aerosol size distribution was changing as time elapsed. Recently, Fujitani et al. generated MWCNTs with a sieve shaker and cyclones [8]. Their reproducibility tests over 2 h indicated that the particle size and total number concentration were stable. However, those batch style aerosol generators may have limitations on long term particle size distribution stability. Usually at the beginning of the aerosol generation, small sized particles are readily suspended in the air.

In this study, a MWCNT aerosolization method with MWCNTs dispersed in water without any surfactant is introduced. MWCNTs dispersed in water were aerosolized with Collision type atomizer and the aerosolized MWCNT shape and concentration were monitored with transmitting electron microscopy (TEM) and an optical particle counter (OPC).

Materials and Methods

MWCNTs

MWCNTs were purchased from Hanwha nanotech (MWCNT CM-95, Korea). The as received MWCNTs were sampled on a TEM grid and the images are shown in Fig. 1. MWCNTs were agglomerated and the fibers were tangled.

Generation of MWCNT aerosol

To aerosolize agglomerated MWCNTs, some mechanical force was applied to break the agglomerates. One g of MWCNT was mixed with 1 liter of deionized water. Dispersion of MWCNTs in water at room temperature was not easy even though ultrasonic agitation was applied. The TEM photographs of the MWCNTs dispersed in water at room temperature showed a tangled shape (Fig. 2A). To disperse the MWCNTs in water without the addition of any surfactant, the MWCNTs were dispersed in water heated to 40°C, 60°C, and 80°C depending

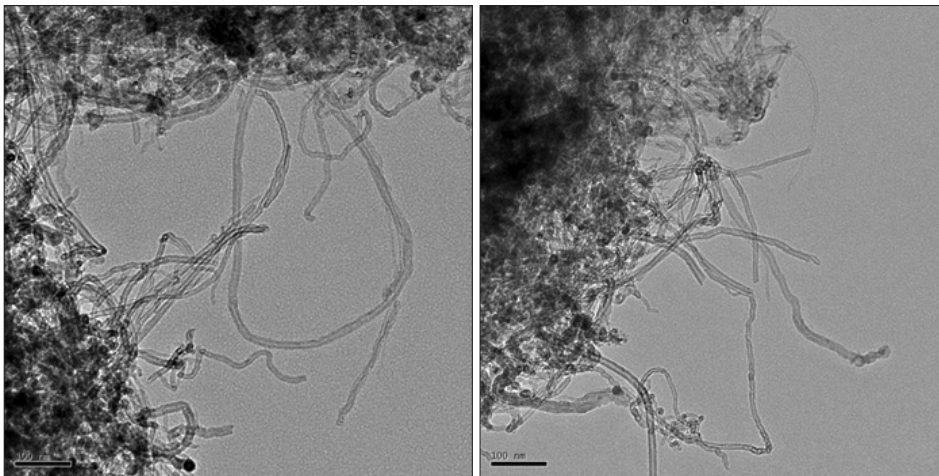

Fig. 1. Multi-walled carbon nano-tube on TEM grid. TEM: transmitting electron microscopy.

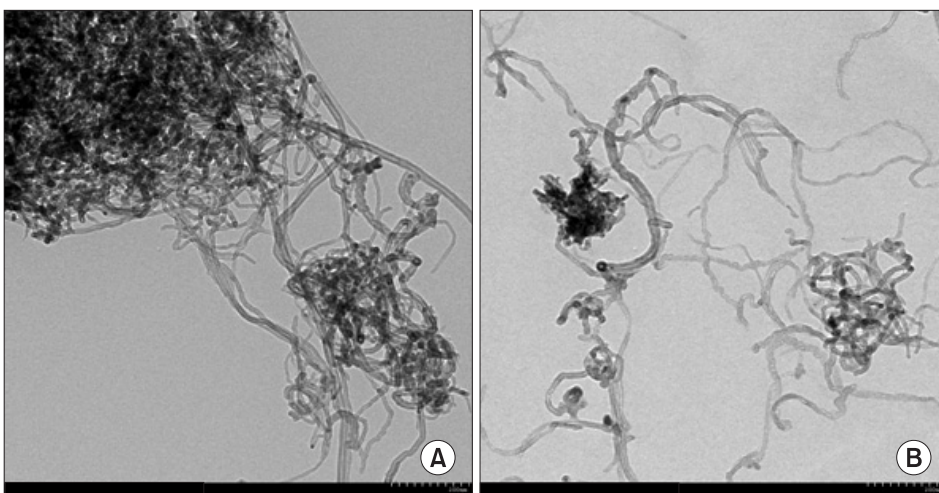

Fig. 2. TEM photographs of MWCNTs dispersed in water. (A) Room temperature. (B) 80°C. TEM: transmitting electron microscopy, MWCNT: multi-walled carbon nanotube.

on the sample. At the high temperature the water surface tension will decrease from 72.75 dyne/cm at 20°C to 62.67 dyne/cm at 80°C [9]. This surface tension decrease facilitates the dispersion of MWCNTs in the water. To increase the dispersion, MWCNTs dispersed in a water bottle was submerged into an ultrasonic bath for 3 hours. The TEM photographs of the MWCNTs dispersed in water at 80°C showed a well dispersed morphology compared with the dispersion at room temperature (Fig. 2B). After sonication the atomization was started. The ultrasonic power was maintained at 160 W and the water bath temperature was maintained at 80°C. The particle free compressed air maintained at 2 atm. was supplied to a 3 jet atomizer. MWCNTs dispersed in water were sprayed by this atomizer and dried by a diffusion dryer. The aerosolized MWCNTs were collected on a TEM grid by the sampler. The morphology of the MWCNTs was photographed by the TEM.

Monitoring of MWCNTs

The mass concentration was monitored by an optical particle counter (Grimm, 1.080). The OPC manufacturer (GRIMM) calibrated the instrument based on filter mass measurements in the factory calibration process. The estimation of mass concentration using an OPC has been known to be suitable for airborne particulate matter [10]. The MWCNT generation system is shown in Fig. 3. The total aerosol flow rate coming from the atomizer was about 15 lpm. The aerosolized MWCNT size distribution was monitored by a scanning mobility particle sizer (SMPS) with a long differential mobility analyzer (DMA) (HCT, SNPS 4220; Korea).

TEM

The air samples were analyzed according to Han et al. [11]. The filter was coated with carbon and mounted onto carbon

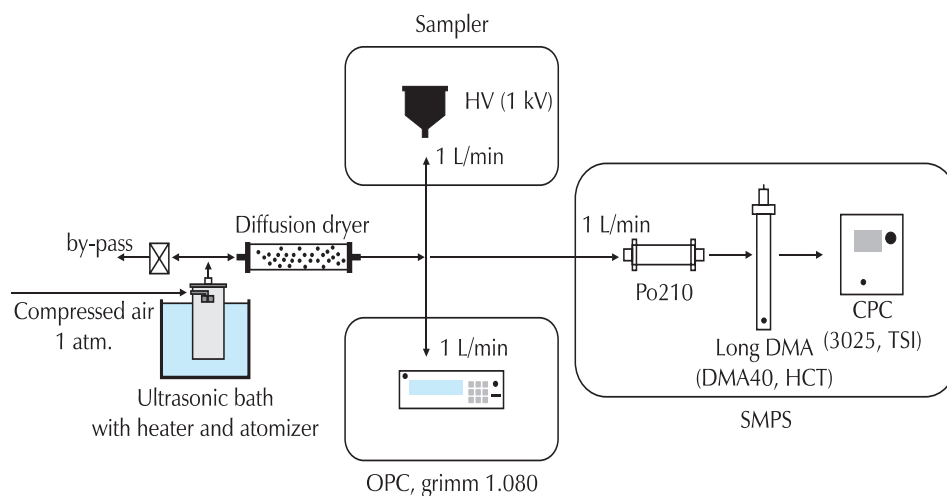

Fig. 3. Experimental set-up for MWCNT atomization system with heated ultrasonic agitation tank. MWCNT: multi-walled carbon nanotube, HV: high voltage, OPC: optical particle counter, CPC: condensation particle counter, DMA: differential mobility analyzer, SMPS: scanning mobility particle sizer.

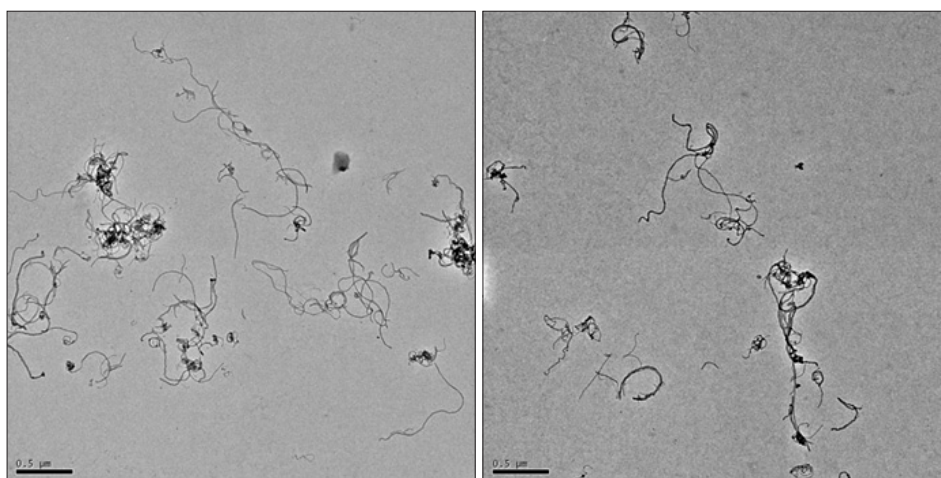

Fig. 4. TEM photographs of MWCNTs. This sample was taken after 3 hours atomization. TEM: transmitting electron microscopy, MWCNT: multi-walled carbon nanotube.

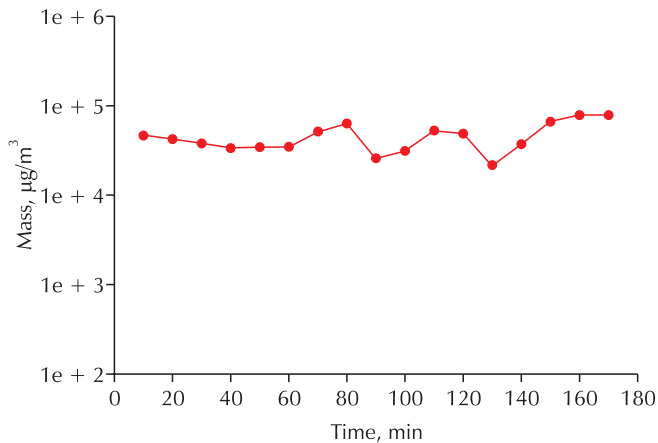

Fig. 5. Aerosolized MWCNT mass concentration changes as a function of time. MWCNT: multi-walled carbon nanotube.

coated copper grids (Veco, Eerbeek, Holland) using acetone vapor. Meanwhile, the CNTs were morphologically identified using a scanning transmission electron microscope (STEM; Hitachi 7100, Tokyo).

Results

The size distribution measurement with the SMPS failed because of anomalous responses in the DMA [12]. The DMA response above 2 kV was not stable. After 3 hours, aerosolized MWCNTs that were atomized were collected on the TEM grid to check its shape. Fig. 4 shows the untangled MWCNTs with good dispersion. The particle mass concentration was monitored with an optical particle counter and about 3 hours of monitoring data is shown in Fig. 5. The generated MWCNT mass concentration is in the range of about a TWA (time weighed average) of 50 mg/m^3 . Although we did not show the data, the MWCNT aerosolized concentration could be controlled by changing the MWCNT solution concentration and/or by changing the dilution air flow rate as usually practiced in inhalation toxicology.

Discussion

Our MWCNT generation system was successfully designed, tested, and is ready to use for inhalation toxicity testing. Our MWCNT generation system met our research objectives, which follow: 1) dispersion of MWCNTs in water without using a surfactant; 2) consistent concentration control for short- and long-term inhalation toxicity testing; 3) more than a 5 mg/m^3 MWCNT concentration for inhalation toxicity testing; and 4) generation of untangled and dispersed MWCNTs as seen in

actual exposure situations described by Han et al. [11].

A previous exposure monitoring study performed in a MWCNT research laboratory by Han et al. showed dispersed MWCNTs with some tangled or clumped structures [11]. In contrast, the exposure monitoring study that took place in seven MWCNT manufacturing workplaces by Lee et al. [13] indicated that the CNT structure could be detected process-dependently because each MWCNT produces quite different forms of particles as well as different fiber-like or non-fiber-like toxic responses, fiber-like structure as seen in Poland et al. [14] and Takagi et al. [15] versus non-fiber-like structure seen in Muller et al. [16]. In this study, we aimed to generate MWCNTs with a dispersed morphology (fiber-like) which may exhibit a higher toxicity than a non-fiber-like morphology, as seen in Muller et al. [16].

Several methods for generating MWCNTs have been described. One system that applied a screw feeder, jet mill, and cut point cyclone to produce a respirable MWCNT aerosol was used to test toxicity of MWCNTs [17]. An ultra high speed knife mill was used to chop single walled CNTs to form small particles [7]. A combination of rotating brush and fluidized bed was employed to generate a MWCNT aerosol [6]. A sieve shaker and cyclones were applied to generate MWCNTs consistently [8]. An acoustic generator with a computer controlled MWCNT generator was used for inhalation toxicity testing [18]. All these methods tried to simulate actual exposure conditions observed in workplaces. In our method of generation, MWCNTs were successfully dispersed in deionized water by heating the water without any surfactant. The aerosolized MWCNTs exhibited a good untangled shape. A very high MWCNT aerosol generation rate of 50 mg/m^3 was also exhibited. This aerosol generation system will be a good tool for inhalation toxicology studies. In this paper, we mostly focused on MWCNT generation with good dispersion without using any surfactant. In future work, we will try to focus on the control of the aerosol output concentration.

Conflict of Interest

No potential conflict of interest relevant to this article was reported.

Acknowledgements

This research was supported by the Nano R&D program through the National Research Foundation of Korea, funded by the Ministry of Education, Science and Technology (2010-0019156).

References

1. Dobrovolskaia MA, McNeil SE. Immunological properties of engineered nanomaterials. *Nat Nanotechnol* 2007;2:469-78.
2. Chakravarty P, Marches R, Zimmerman NS, Swafford AD, Bajaj P, Musselman IH, Pantano P, Draper RK, Vitetta ES. Thermal ablation of tumor cells with antibody-functionalized single-walled carbon nanotubes. *Proc Natl Acad Sci U S A* 2008;105:8697-702.
3. Maynard AD, Baron PA, Foley M, Shvedova AA, Kisin ER, Castranova V. Exposure to carbon nanotube material: aerosol release during the handling of unrefined single-walled carbon nanotube material. *J Toxicol Environ Health A* 2004;67:87-107.
4. Shvedova AA, Castranova V, Kisin ER, Schwegler-Berry D, Murray AR, Gandelsman VZ, Maynard A, Baron P. Exposure to carbon nanotube material: assessment of nanotube cytotoxicity using human keratinocyte cells. *J Toxicol Environ Health A* 2003;66:1909-26.
5. Tabet L, Bussy C, Amara N, Setyan A, Grodet A, Rossi MJ, Pairon JC, Boczkowski J, Lanone S. Adverse effects of industrial multiwalled carbon nanotubes on human pulmonary cells. *J Toxicol Environ Health A* 2009;72:60-73.
6. Myojo T, Oyabu T, Nishi K, Kadoya C, Tanaka I, Ono-Ogasawara M, Sakae H, Shirai T. Aerosol generation and measurement of multi-wall carbon nanotubes. *J Nanopart Res* 2009;11:91-9.
7. Baron PA, Maynard AD, Foley M. Evaluation of aerosol release during the handling of unrefined single walled carbon nanotube material. NIOSH 2003; DART-02-191 Rev. 1.1.
8. Fujitani Y, Furuyama A, Hirano S. Generation of airborne multi-walled carbon nanotubes for inhalation studies. *Aerosol Science Technology* 2009;43:881-90.
9. Lide DR. CRC handbook of chemistry and physics. 77th ed. New York: CRC Press; 1997. p. 6-3.
10. Tittarelli A, Borgini A, Bertoldi M, De Saeger E, Ruprecht A, Stefanoni R, Tagliabue G, Contiero P, Crosignani P. Estimation of particle mass concentration in ambient air using a particle counter. *Atmospheric Environ* 2008;42:8543-8.
11. Han JH, Lee EJ, Lee JH, So KP, Lee YH, Bae GN, Lee SB, Ji JH, Cho MH, Yu IJ. Monitoring multiwalled carbon nanotube exposure in carbon nanotube research facility. *Inhal Toxicol* 2008;20:741-9.
12. Ku BK, Maynard AD, Baron PA, Deye GJ. Observation and measurement of anomalous responses in a differential mobility analyzer caused by ultrafine fibrous carbon aerosols. *J Electrostatics* 2007;65:542-8.
13. Lee JH, Lee SB, Bae GN, Jeon KS, Yoon JU, Ji JH, Sung JH, Lee BG, Lee JH, Yang JS, Kim HY, Kang CS, Yu IJ. Exposure assessment of carbon nanotube manufacturing workplaces. *Inhal Toxicol* 2010;22:369-81.
14. Poland CA, Duffin R, Kinloch I, Maynard A, Wallace WA, Seaton A, Stone V, Brown S, Macnee W, Donaldson K. Carbon nanotubes introduced into the abdominal cavity of mice show asbestos-like pathogenicity in a pilot study. *Nat Nanotechnol* 2008;3:423-8.
15. Takagi A, Hirose A, Nishimura T, Fukumori N, Ogata A, Ohashi N, Kitajima S, Kanno J. Induction of mesothelioma in p53+/- mouse by intraperitoneal application of multi-wall carbon nanotube. *J Toxicol Sci* 2008;33:105-16.
16. Muller J, Delos M, Panin N, Rabolli V, Huaux F, Lison D. Absence of carcinogenic response to multiwall carbon nanotubes in a 2-year bioassay in the peritoneal cavity of the rat. *Toxicol Sci* 2009;110:442-8.
17. Mitchell LA, Gao J, Wal RV, Gigliotti A, Burchiel SW, McDonald JD. Pulmonary and systemic immune response to inhaled multiwalled carbon nanotubes. *Toxicol Sci* 2007;100:203-14.
18. McKinney W, Chen B, Frazer D. Computer controlled multi-walled carbon nanotube inhalation exposure system. *Inhal Toxicol* 2009;21:1053-61.