

Video Article

A Lightweight, Headphones-based System for Manipulating Auditory Feedback in Songbirds

Lukas A. Hoffmann^{1,2}, Conor W. Kelly^{1,3}, David A. Nicholson^{1,2}, Samuel J. Sober¹¹Department of Biology, Emory University²Neuroscience Graduate Program, Emory University³Program in Neuroscience and Behavioral Biology, Emory UniversityCorrespondence to: Samuel J. Sober at samuel.j.sober@emory.eduURL: <http://www.jove.com/video/50027>DOI: [doi:10.3791/50027](https://doi.org/10.3791/50027)

Keywords: Neuroscience, Issue 69, Anatomy, Physiology, Zoology, Behavior, Songbird, psychophysics, auditory feedback, biology, sensorimotor learning

Date Published: 11/26/2012

Citation: Hoffmann, L.A., Kelly, C.W., Nicholson, D.A., Sober, S.J. A Lightweight, Headphones-based System for Manipulating Auditory Feedback in Songbirds. *J. Vis. Exp.* (69), e50027, doi:10.3791/50027 (2012).

Abstract

Experimental manipulations of sensory feedback during complex behavior have provided valuable insights into the computations underlying motor control and sensorimotor plasticity¹. Consistent sensory perturbations result in compensatory changes in motor output, reflecting changes in feedforward motor control that reduce the experienced feedback error. By quantifying how different sensory feedback errors affect human behavior, prior studies have explored how visual signals are used to recalibrate arm movements^{2,3} and auditory feedback is used to modify speech production⁴⁻⁷. The strength of this approach rests on the ability to mimic naturalistic errors in behavior, allowing the experimenter to observe how experienced errors in production are used to recalibrate motor output.

Songbirds provide an excellent animal model for investigating the neural basis of sensorimotor control and plasticity^{8,9}. The songbird brain provides a well-defined circuit in which the areas necessary for song learning are spatially separated from those required for song production, and neural recording and lesion studies have made significant advances in understanding how different brain areas contribute to vocal behavior⁹⁻¹². However, the lack of a naturalistic error-correction paradigm - in which a known acoustic parameter is perturbed by the experimenter and then corrected by the songbird - has made it difficult to understand the computations underlying vocal learning or how different elements of the neural circuit contribute to the correction of vocal errors¹³.

The technique described here gives the experimenter precise control over auditory feedback errors in singing birds, allowing the introduction of arbitrary sensory errors that can be used to drive vocal learning. Online sound-processing equipment is used to introduce a known perturbation to the acoustics of song, and a miniaturized headphones apparatus is used to replace a songbird's natural auditory feedback with the perturbed signal in real time. We have used this paradigm to perturb the fundamental frequency (pitch) of auditory feedback in adult songbirds, providing the first demonstration that adult birds maintain vocal performance using error correction¹⁴. The present protocol can be used to implement a wide range of sensory feedback perturbations (including but not limited to pitch shifts) to investigate the computational and neurophysiological basis of vocal learning.

Video Link

The video component of this article can be found at <http://www.jove.com/video/50027/>

Protocol

Implementing the headphones system consists of four major steps. Section 1 below details the assembly of the headphones frame, which houses the electronics (speakers and a miniaturized microphone). Section 2 describes how the frame is attached to the bird. Section 3 describes the assembly of the electronics. Section 4 explains how the electronics are connected to sound-processing and data-collection hardware and details a procedure for testing that the system is functioning correctly.

1. Fabricate Headphone Frame

1. Cut carbon fiber components for crossbar and earbuds. Use the cutting wheel on a Dremel tool to prepare the following pieces:
 - 1 crossbar (3 cm of 1 x 3 mm carbon fiber strip)
 - 2 vertical struts (1.5 cm of 1 x 3 mm carbon fiber strip)
 - 2 earbuds (4 mm of 4 mm ID/ 6 mm OD carbon fiber cylinder)
2. Assemble crossbar. Drill two small holes 4.5 mm apart in the center of the crossbar (**Figure 1a**, top) using a 1.4 mm diameter bit. Holes should be just large enough to accommodate the 0-80 screw. Insert two 0-80 screws through the holes and attach hex nuts. Cut two 6 mm strips of syringe needle (any small-diameter needle will work) and flatten with pliers (needle strips shown in red in **Figure 1a**). Turn

the crossbar over so the hex nuts lie on top. To prevent epoxy from gluing the tip of the screws to the hex nuts put a drop of mineral oil (shown in green in **Figure 1a**) on the tip of each screw. Place the two needle segments on top of the hex nuts. Epoxy hex nuts to each other and the needle segments, covering both (**Figure 1a**, bottom). After epoxy has fully cured (24 hr), remove both screws. The crossbar unit should separate into four components: two screws, the 3 cm length of carbon fiber, and a single piece consisting of 2 hex nuts and 2 needle segments glued together with epoxy. Reassemble crossbar unit.

3. Fabricate foam rings. Use a 1/4 in (6.35 mm) hole punch to cut a foam cylinder from a foam earplug. Use scissors to cut perpendicular to the long axis of the foam cylinder yielding a 2 mm (length) by 6.35 mm (diameter) cylinder. Then use a 1/8 in (3.175 mm) hole punch to cut out the center of the 2 mm foam cylinder, forming a foam ring (shown in orange in **Figure 1b**).
4. Assemble earbuds. Use epoxy to glue vertical struts (1.5 cm length of carbon fiber strip) to the 4mm length of carbon fiber cylinder as shown in **Figure 1b**, bottom. When epoxy has hardened, use a small amount of epoxy to glue the foam ring to the end of the cylinder (**Figure 1b**, bottom). The foam ring will rest against the bird's head.

2. Attach Headphones Frame to Bird

1. Prepare stereotax. Prior to surgery, insert stereotax earbars through earbuds with the foam pads facing inwards (**Figure 1c**, top).
2. Attach crossbar. Anesthetize the bird using isoflurane and/or ketamine plus midazolam. The anesthetized bird should have closed eyes and be unresponsive to toe pinch. Place bird in stereotax and make a 5-10 mm incision in scalp. The incision should be along the midline and extend anterior from a point 2 mm anterior of the attachment of the neck muscles at the back of the skull. Rub the exposed skull with 70% ethanol to dry the bone surface. Use an alligator clip holder to place crossbar such that the epoxy-covered hex nuts rest on the top of the skull (**Figure 1c**, d). Lift the crossbar slightly and glue the hex nuts (with epoxy or dental acrylic) to the skull, being careful that the adhesive touches ONLY the hex nuts and not the crossbar itself. This will allow you to remove the headphones (by removing the screws), leaving only the hex nuts permanently attached to the head (**Figure 1d**).
3. Attach earbuds. Slide earbuds along ear bars until foam pads rest against the bird's head (**Figure 1c**, top). Use alligator clips on the ear bars to press foam pads firmly against the bird's head (**Figure 1c**, bottom), this is important to getting a good acoustic seal. Rotate earbuds so that the vertical posts touch the back of the crossbar, leaving space for the connector strip socket (**Figure 2**) in front of the post. Glue posts to crossbar using epoxy or acrylic.
4. Recovery. Allow 24 hr for epoxy/acrylic to fully cure and bird to recover. After recovery, examine frames to make sure foam pads form a tight seal around ear canals. If seal is loose, foam pads can be removed and replaced with larger ones to improve acoustic seal. Gently remove screws using a 0.05 in (1.27 mm) hexagonal wrench and remove assembled headphones frame from the bird.

3. Assemble Electronics

1. Fabricate speaker adapters. Make speaker adapters by inserting a pipet tip (a 5.2 cm long tip with a diameter that tapers from 5 mm to 1 mm) into a scrap piece of carbon fiber cylinder (use the same 4 mm ID/ 6 mm OD cylinder stock as for the earbuds; length of the cylinder scrap is not important), then cut pipet tip 1 mm past the end of the cylinder (**Figure 2a**). Remove from cylinder and cut so that the total length of the adapter is 3 mm.
2. Connect speakers. Solder 5 cm lengths of insulated 36 ga. wire to the positive and negative terminals of both speakers (green and black wires, respectively, in **Figure 2d**, e). Use an ohmmeter to verify that neither terminal is in electrical contact with the speaker's metal casing.
3. Assemble speaker/microphone component. Epoxy a strip of tape (any electrically insulating tape will work) to one side of one speaker and epoxy the headphones mic on top of the tape (**Figure 2b**). Solder the ground wire from the microphone to the negative terminal on the speaker (connection shown in black in **Figure 2e**).
4. Epoxy both the speaker and the speaker/microphone component into the wider end of each adapter (**Figure 2c**, right). Both the speaker and microphone port will (just) fit inside the pipet. Be sure that epoxy does not cover either port.
5. Gently insert adapters into the earbuds (**Figure 2d**, right). Glue each adapter to its earbud with a small drop of epoxy.
6. Fabricate connector strip. Cut a segment of connector strip socket consisting of four terminals and place a reference mark (white dot in **Figure 2d**) on one corner of the socket. Position the connector strip near one of the vertical posts. Solder the speaker and microphone wires to the pins in the configuration shown in **Figure 2e**. Use an ohmmeter to check for short circuits on connector strip and repair if necessary. Epoxy the connector strip to the headphones frame. Wrap strips of electrical or scotch tape around exposed wires to protect wires and add thin layer of epoxy over tape ends to prevent unraveling. The finished weight of the headphones (including frame and electronics) should be 1.3-1.5 g.
7. Build a flexible lead by soldering four 15 cm lengths of insulated 36 ga. wire to a segment of connector strip header consisting of four terminals (**Figure 3a**). Place a reference mark (white dot in **Figure 3**) on one corner of the header to ensure that the lead is plugged into the socket in the correct orientation. Braid wires and finish lead by soldering wires to an adapter that plugs into commutator (**Figure 3b**).

4. Connect Headphones Electronics to Power and Signal Processing Equipment

1. Collect, filter, pitch shift, and amplify acoustic input. Hang an omnidirectional condenser microphone ("Cage mic," **Figure 4**) directly above the bird's cage. Preamplify and low-pass filter this signal (cutoff at 10 kHz for finch song) and input it into the Harmonizer (or other realtime sound-processing hardware). Use the pitch shifter module on the Harmonizer to generate a shifted acoustic signal. Amplify this signal and route it (via the commutator and flexible lead) to the positive channel on the speaker headphones (green in **Figure 2e**).
2. Provide power to phones mic. Attach a 9V battery to the wall of the bird's soundbox. Connect the positive terminal of the battery to the V+ channel (red in **Figure 2e**) via the commutator and flexible lead, connecting the battery's negative terminal to a common ground on the signal processing equipment. Connect this common ground to the speaker and phones mic ground (black in **Figure 2e**).
3. Calibrate feedback gain. Attach finished headphones to the hex nuts on bird's head using 0-80 screws. When bird begins singing, record three channels of data (cage mic/unshifted signal, shifted signal, and phones mic) as shown in **Figure 4**. Examine the sound recorded from the phones mic. This channel will record the superposition of the virtual feedback (played through the headphones speaker) and the bird's actual song "leaking" directly into the headphones frame. Adjust amplitude setting of speaker amplifier (**Figure 4**) so that the virtual auditory feedback is 15-20 dB louder than the direct/leaking signal. Note that increasing the amplitude beyond this threshold can result in the

virtual signal bleeding through the headphones and being picked up by the cage mic, resulting in feedback distortion. An example of a well-calibrated system (in which the signal recorded by the headphones mic is dominated by the pitch-shifted signal rather than the direct/leaking signal) is shown in **Figure 5**. Here, the signal recorded through the headphones microphone (**Figure 5a**, right) is dominated by the pitch-shifted signal (rather than the bird's natural vocalization), as shown in the example power spectrum in **Figure 5b**.

4. Monitor system performance. Check headphones twice daily to insure that both speakers and the microphone are functioning properly. Note that the headphones mic only monitors one of the speakers. To test the other speaker, tap the cage mic while holding the non-monitored speaker next to your ear - you will hear a clicking sound if the non-monitored speaker is working. Another recommended check is to disconnect the power source and signal output from the phone mic and use an ohmmeter to measure the resistance across the speakers (black and green in **Figure 2e**). When both speakers are connected, this will be half of the resistance across a single speaker since speakers are connected in parallel.

5. A Note on the Cost of Materials

With two notable exceptions, all items listed in the Table of Materials are relatively inexpensive (less than a few hundred US dollars). The most costly components are the commutator and the Harmonizer listed in the Table, which each cost 2,000 US dollars or more. We note that less expensive versions of both items may be available from different manufacturers than the ones listed (although we have not tested them) and might allow researchers to implement this protocol at a lower cost.

Representative Results

Figure 6 shows a representative experiment performed on an adult Bengalese finch. Here, the headphones system was used to increase the pitch of auditory feedback by one semitone (one twelfth of an octave, representing an approximately 6% change in absolute frequency) for 16 days. This manipulation resulted in a gradual reduction of the pitch of all song syllables (colored lines). This change in the vocal motor program resulted in a reduction in the auditory error experienced by the bird (dashed line), demonstrating the bird's reliance on auditory feedback to correct apparent vocal errors. When the pitch shift was removed after day 16, the pitch of song eventually returned to baseline.

The data shown in **Figure 6** are typical in that they reflect incomplete adaptation. Here, although the pitch of auditory feedback was shifted by 1.0 semitones, the bird changed the pitch of his song by only about 0.4 semitones. Across species and systems, incomplete adaptation is the norm when virtual feedback is used to perturb a single sensory modality^{5,15}, and in the present paradigm likely reflects a partial reliance on nonauditory (e.g. proprioceptive) signals as songbirds evaluate their ongoing vocal performance.

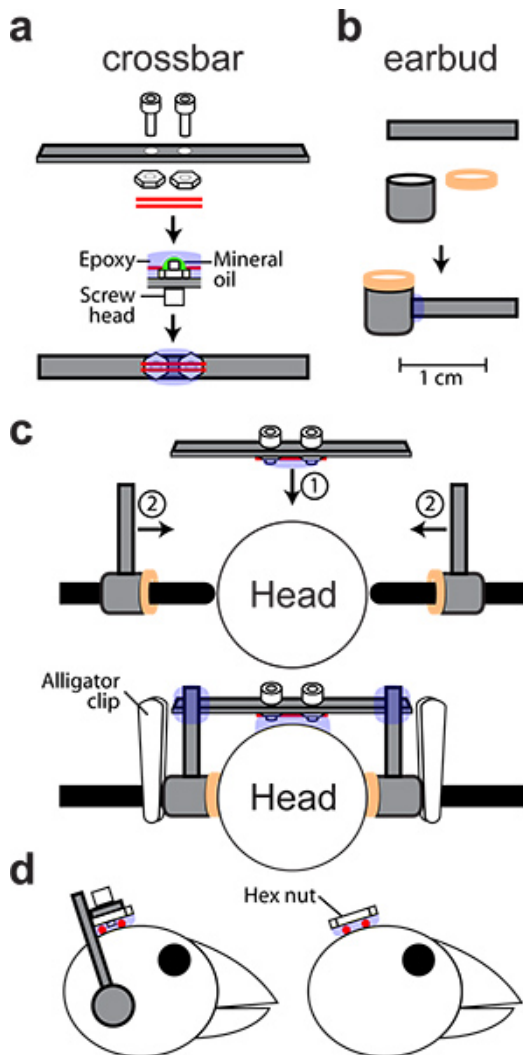

Figure 1. Headphones frame assembly. **a.** Crossbar assembly. Attach screws, crossbar, hex nuts, and syringe needles (red) using epoxy adhesive (blue) as shown. Cover the tip of each screw with mineral oil (green) to prevent epoxy from bonding to screws. **b.** Earbud assembly. Attach post, cylinder, and foam pad (orange) with epoxy. **c.** Fitting headphones frame. Prior to surgery, thread stereotax earbars (black) through earbuds. Attach crossbar to skull using epoxy or dental acrylic (blue), then attach earbuds to crossbar using alligator clips to gently press the foam pads against the bird's head. **d.** Left, side view illustrating positioning of crossbar and earbuds on bird's head. Right, side view of the hex nut assembly attached to the skull after the headphones frame has been removed by detaching the screws. Scale bar in **b** pertains to all panels.

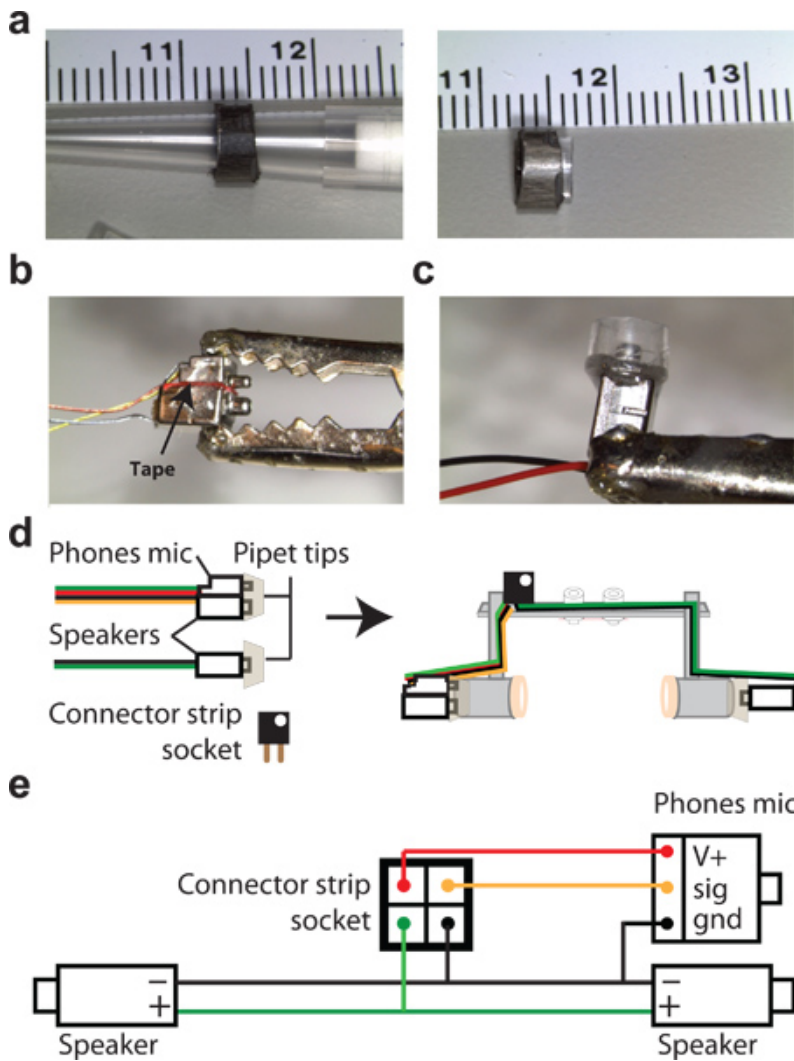

Figure 2. Electronics assembly. **a.** Make an adapter by inserting a pipet tip into a scrap piece of carbon fiber cylinder and cutting pipet tip to length. **b.** Using epoxy, glue one speaker and headphones mic together separated by a piece of tape. **c.** Glue adapter onto speaker (shown) and speaker/phones mic component. **d.** Solder wires from speakers and headphones mic to a connector strip socket and glue the socket to the top of the headphones frame. White dot, alignment mark on connector strip socket. **e.** Wiring diagram showing connections between speakers, headphones mic, and socket.

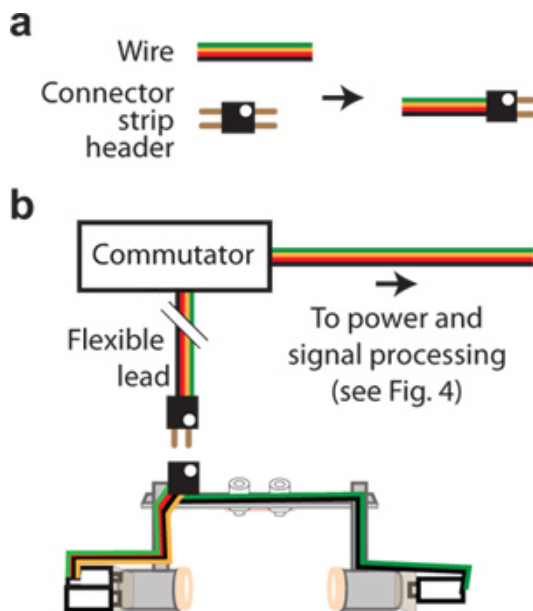

Figure 3. Lead assembly. **a.** Fabricate a flexible lead by soldering four 15 cm lengths of wire to the pins on one side of a connector strip header and braid wires together. Solder the other end of the lead wires to an adapter connecting to commutator. White dot, alignment mark on connector strip header. **b.** Plug lead into connector strip socket on headphones to carry altered auditory feedback to headphones speaker, power the headphones mic, and record the signals from the headphones mic. Align dots on connector strip header and socket to ensure correct connectivity.

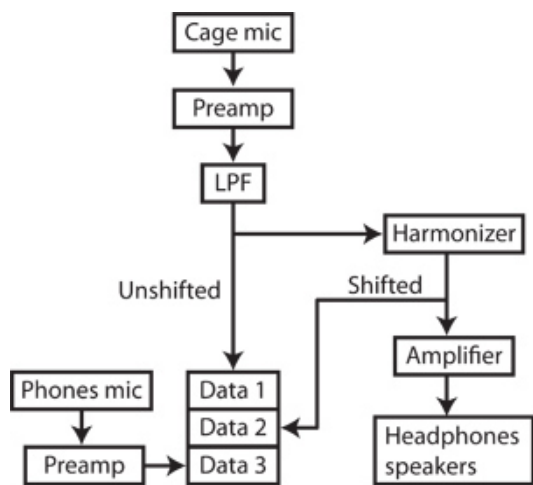

Figure 4. Circuit summary. Flowchart summarizing system connectivity. The three data channels record (1) the unshifted signal from the cage microphone, (2) a copy of the pitch-shifted signal sent to the headphones speakers, and (3) the sound waveform recorded by the headphones mic. Preamp, microphone preamplifier; LPF, low-pass filter.

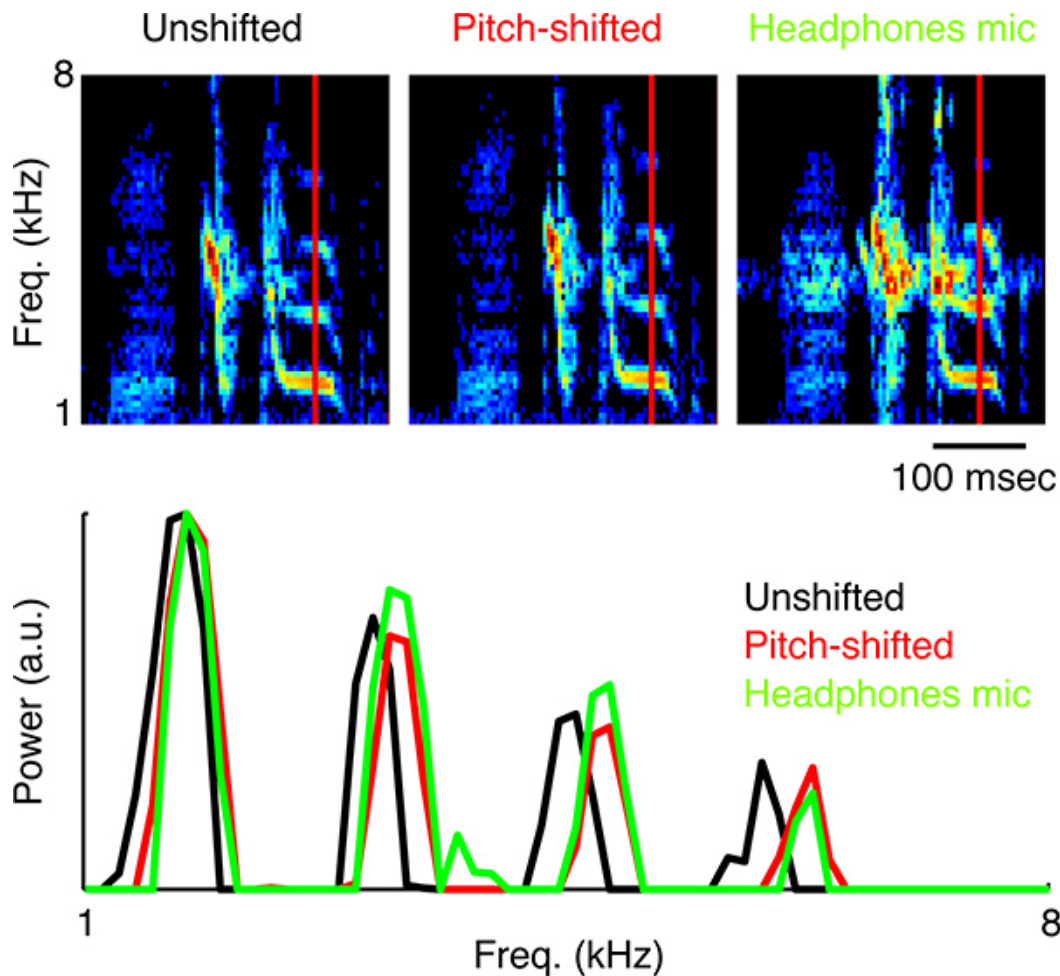

Figure 5. Testing the system. **a.** Spectrograms of sound recorded on the three data channels. Each data channel shows three song syllables. Color represents power at each time and acoustic frequency. **b.** Power spectrum at the time indicated by the vertical red lines in **a.** Note that the peaks in the headphones mic spectrum (green) match the peaks in the pitch-shifted (red) rather than the unshifted (black) signal, indicating that the sound reaching the bird's ear is dominated by the shifted feedback.

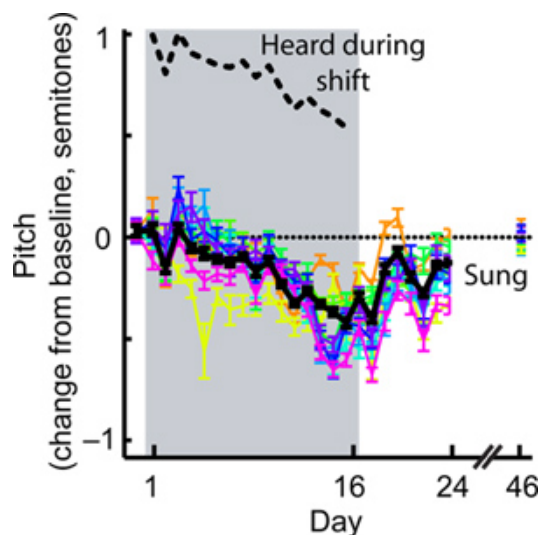

Figure 6. Using the headphones system to drive vocal learning. Vocal error correction in an adult Bengalese finch. Colored lines show changes in the pitch of seven different song syllables during a 16-day period (gray box) in which the headphones system was used to shift the pitch of auditory feedback upwards by one semitone. Solid black line, mean pitch change across all song syllables. Dashed black line shows the mean pitch error experienced by the subject during the shift epoch. Note that the change in song pitch serves to reduce the experienced pitch error. After the pitch shift was set back to zero on day 17 pitch approaches baseline. On day 24 the headphones were removed, and then replaced on day 46, at which time pitch had recovered back to its baseline value.

Discussion

The protocol presented here allows the experimenter to manipulate auditory feedback in singing birds. The lightweight construction allows such manipulations to be sustained over long periods, and birds will sing prolifically while wearing headphones for a month or more. Although some songbirds will sing for as long as 10 weeks wearing headphones, in some cases the amount of singing begins to decline after ~5 weeks of use. For this reason, we typically limit experiments to 4 weeks. In our experience, every songbird fitted with headphones can be expected to sing 100+ song bouts per day (and sometimes much more). Therefore, if properly employed, the headphones system offers a nearly 100% success rate (if success is defined by the acquisition of data from singing birds). Furthermore, after completing one learning experiment the headphones can be removed and subsequently reattached for further data collection. Provided that the animal is in good general health reattachment can take place at any time.

One important determinant of success is minimizing the weight and optimizing the comfort of the headphones. During construction, care should be taken to minimize the amount of epoxy or dental acrylic used as excess adhesive will increase the overall weight of the apparatus and potentially reduce the bird's willingness to sing. Additionally, several days after attaching the headphones, the apparatus should be briefly removed to verify that the skin around the ear canals has not become irritated by the earbuds, which can occur if the earbuds are too tight. The ear canals should appear just as they did at the time of headphones attachment (open and with no signs of redness or swelling). If irritation occurs, pressure can be alleviated by reducing the thickness of the foam pads. Take care to ensure that foam hardened by dried epoxy does not contact the bird's skin, as this will also cause irritation.

It is important to note that in addition to the pitch shift selected by the experimenter, virtual auditory feedback is also delayed (by ~10 msec, reflecting the processing latency of the Harmonizer) and is introduced at a greater amplitude than the bird's natural auditory feedback (in order to drown out the sound of the bird's natural song "leaking" into the headphones). For this reason, experiments should begin with a baseline period of several days in which the bird sings with the headphones on but with zero pitch shift¹⁴, allowing the effect of the pitch shift to be isolated from vocal changes resulting from other factors related to the headphones paradigm. In practice, changes in song pitch or amplitude are seldom observed when birds first begin to sing with headphones in the absence of a pitch shift. Furthermore, we have shown that extended exposure to unshifted feedback delivered via headphones does not cause a change in song pitch¹⁴.

We have previously used this design to demonstrate that in adult songbirds, both upward and downward shifts in the pitch of auditory feedback generate adaptive changes in vocal pitch (*i.e.* changes opposite in sign to the feedback shift)¹⁴. Including both upward and downward shifts in any experiment employing this paradigm is important because such a design can demonstrate that song pitch changes in response to changes in the pitch of auditory feedback (and not in response to the delay or amplitude artifacts introduced by the headphones). Additionally, a key strength of this paradigm is that it can be used to introduce arbitrary auditory manipulations. The Harmonizer system can generate a wide variety of online perturbations, for example by altering the amplitude or spectral envelope of the acoustic signal. Expanding the range of manipulations beyond pitch shifts could therefore be used to examine a variety of vocal learning phenomena. Additionally, the headphones could be used to deliver white noise or other conditional reinforcement signals to drive learning in individual syllables¹⁶. Finally, this paradigm could in principle be employed in any small animal system that relies on auditory feedback during vocal behavior.

We note that our technique, which mimics auditory feedback manipulations used to study human speech⁴⁻⁷, allows vocal plasticity to be investigated in a physiologically accessible animal model. Combining behavioral studies of vocal error correction with brain lesions, pharmacological manipulations, or neural recordings could be used to reveal how particular neural circuits contribute to the correction of errors in vocal performance.

Disclosures

No conflicts of interest declared.

Acknowledgements

This work was supported by NINDS 5P30NS069250. We thank Diala Chehayeb, Jeffrey Simpson, Taylor Rosenbaum, and Christopher Hoover for technical assistance.

References

1. Shadmehr, R., Smith, M.A., & Krakauer, J.W. Error correction, sensory prediction, and adaptation in motor control. *Annu. Rev. Neurosci.* **33**, 89-108, doi:10.1146/annurev-neuro-060909-153135 (2010).
2. Krakauer, J.W., Pine, Z.M., Ghilardi, M.F., & Ghez, C. Learning of visuomotor transformations for vectorial planning of reaching trajectories. *J. Neurosci.* **20**, 8916-8924 (2000).
3. Krakauer, J.W., Ghilardi, M.F., & Ghez, C. Independent learning of internal models for kinematic and dynamic control of reaching. *Nature Neuroscience*. **2**, 1026-1031, doi:10.1038/14826 (1999).
4. Chen, S.H., Liu, H., Xu, Y., & Larson, C.R. Voice F0 responses to pitch-shifted voice feedback during English speech. *J. Acoust. Soc. Am.* **121**, 1157-1163 (2007).
5. Houde, J.F. & Jordan, M.I. Sensorimotor adaptation in speech production. *Science*. **279**, 1213-1216 (1998).
6. Jones, J.A. & Munhall, K.G. Perceptual calibration of F0 production: evidence from feedback perturbation. *J. Acoust. Soc. Am.* **108**, 1246-1251 (2000).
7. Liu, H. & Larson, C.R. Effects of perturbation magnitude and voice F0 level on the pitch-shift reflex. *J. Acoust. Soc. Am.* **122**, 3671-3677 (2007).
8. Doupe, A.J. & Kuhl, P.K. Birdsong and human speech: common themes and mechanisms. *Annu. Rev. Neurosci.* **22**, 567-631 (1999).
9. Mooney, R. Neural mechanisms for learned birdsong. *Learn Mem.* **16**, 655-669, doi:10.1101/lm.1065209 (2009).
10. Brainard, M.S. & Doupe, A.J. Interruption of a basal ganglia-forebrain circuit prevents plasticity of learned vocalizations. *Nature*. **404**, 762-766, doi:10.1038/35008083 (2000).
11. Chi, Z. & Margoliash, D. Temporal Precision and Temporal Drift in Brain and Behavior of Zebra Finch Song. *Neuron*. **32**, 899-910 (2001).
12. Sober, S.J., Wohlgenuth, M.J., & Brainard, M.S. Central contributions to acoustic variation in birdsong. *J. Neurosci.* **28**, 10370-10379, doi:10.1523/JNEUROSCI.2448-08.2008 (2008).
13. Kao, M.H., Doupe, A.J., & Brainard, M.S. Contributions of an avian basal ganglia-forebrain circuit to real-time modulation of song. *Nature*. **433**, 638-643 (2005).
14. Sober, S.J. & Brainard, M.S. Adult birdsong is actively maintained by error correction. *Nat. Neurosci.* **12**, 927-931, doi:10.1038/nn.2336 (2009).
15. Choe, C.S. & Welch, R.B. Variables affecting the intermanual transfer and decay of prism adaptation. *J. Exp. Psychol.* **102**, 1076-1084 (1974).
16. Tumer, E.C. & Brainard, M.S. Performance variability enables adaptive plasticity of 'crystallized' adult birdsong. *Nature*. **450**, 1240-1244 (2007).