

## NOTES

### CAPILLARY TUBE METHOD FOR COUNTING VIABLE BACTERIA

TOMOMICHI YANAGITA

*Institute of Food Microbiology, Chiba University, Japan*

Received for publication September 12, 1955

To simplify the counting of viable bacterial cells, a new method was developed in our laboratory and has been used quite satisfactorily for several years.

The bacterial suspension is properly diluted with saline in a test tube to obtain 1,000 to 10,000 cells per ml. One-half ml of this suspension is mixed thoroughly with 4.5 ml of melted nutrient

desirable for strength and to magnify the colonies formed inside the tube.

After leaving the capillaries at room temperature until the agar hardens, they are placed horizontally into an incubator at 37 C for 24 hr. Each group of triplicate capillaries is held together with a paper band marked with proper notations.

Subsequently colonies are counted in a special device (see figures 1 and 2). The capillary is put into the horizontal metal tube of the counter in one end and shifted slowly toward the other end.



*Figure 1.* Special colony counter. The instrument was constructed by Mr. Y. Maruyama of our laboratory.

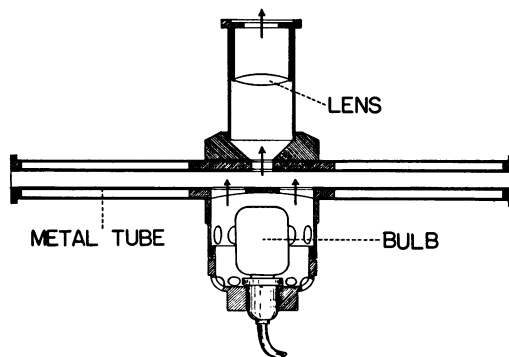

*Figure 2.* Sectional view of a colony counter (Reduction is 63.7%). Arrows indicate the path of light.

agar (nutrient broth and 0.5 per cent sodium nitrate and 0.8 per cent agar) in a test tube. The inoculated agar then is sucked into 3 capillaries, each of which has 2 marks calibrated to indicate a total volume of 0.5 ml. Dimensions of the capillary tubes are as follows: total length, 400 mm; outside diameter, 5 mm; inside diameter, 1.3 to 1.6 mm; and the length between 2 marks, 250 to 380 mm. A rather thick wall of the capillary is

Colonies formed in the capillary are observed through a lens; the dark field illumination is obtained by a device at the bottom of the metal tube. Counting the colonies is very easy because of their almost one-dimensional arrangement in the capillary and marking of the colonies once counted is unnecessary.

Viable counts obtained by this method are practically identical with those obtained by plate counts. The accuracy of counting by this method appears considerably higher than that of plate counts, since more than 1,000 cells per ml can be counted easily. Advantages of this method are

(1) ease of counting, (2) high accuracy, (3) space saving in an incubator, (4) reduced chances of contamination, and (5) inexpensiveness of the capillaries. This method has limitations since it can be used only with anaerobes and facultative

anaerobes that do not form gas. *Escherichia coli*, *Micrococcus pyogenes* var. *aureus* and *Lactobacillus casei* are the organisms which have been counted successfully by this method in our laboratory.

## PARTIAL PURIFICATION OF CELLULASE FROM A WOOD-ROTTING BASIDIOMYCETE

HARRY H. HIGA,<sup>1</sup> R. D. O'NEILL AND M. W. JENNISON

Laboratories of Microbiology, Department of Plant Sciences, Syracuse University, Syracuse, N. Y.

Received for publication September 30, 1955

In a recent series of communications, Whitaker has reported (Arch. Biochem. and Biophys., **43**, 253, 1953; **49**, 257, 1954) procedures for purification of cellulase from *Myrothecium verrucaria*. These and most other studies of enzymatic hydrolysis of cellulose (see Siu and Reese, Botan. Rev., **19**, 377, 1953) have employed preparations from organisms which are incapable of depolymerizing cellulose as found complexed with lignin in wood. *Polyporus palustris* is among those unique fungal types which can utilize the cellulose of wood, leaving a brown, lignin-rich residue. Because this fungus consistently produced cellulase in demonstrable quantities in a synthetic medium, it was selected as the source of enzyme for a series of studies currently in progress. The purpose of this preliminary report is to present a method for the concentration and partial purification of cellulase from this wood-rotting organism. The ultimate objective of our studies is to define the differences, if any, between enzymic attack on cellulose coupled with lignin and on uncomplexed cellulose.

The organism was grown in a synthetic medium (glycerol, glutamic acid, thiamin and inorganic salts) in submerged culture for 15 days at 28 C. Cell-free culture filtrates were then passed through "Nalcite HCR" cation exchange resin and the effluent dialyzed in a collodion membrane

having an alcohol index of 15. Concentration of the dialyzed material to  $\frac{1}{40}$  of its original volume was effected by evaporation in a forced air draft at 25 C; the sediment was removed by centrifugation, and discarded. The enzymatically-active fraction was precipitated from the concentrate by absolute ethanol (3 parts ethanol cooled to -15 C to one part of 40 $\times$  concentrate cooled to 2 C) and the mixture centrifuged. The supernatant was discarded and the precipitate then dissolved in Clark and Lubs phthalate buffer, pH 4.4, at 4 C. This buffer-enzyme mixture, upon evaporation to dryness by forced air draft in the cold, yielded two crystalline forms: one large and irregular, and the other considerably smaller, more uniform and of rectangular shape. The former was soluble in cold distilled water and contained buffer salts as shown by a positive phthalic anhydride reaction. The latter crystals were insoluble in cold water and negative for phthalic anhydride. Both types gave a positive ninhydrin reaction and in solution both showed enzyme activity against carboxymethyl cellulose and against filter paper treated with cold phosphoric acid, using the Somogyi iodometric dextrose test as a measure of hydrolysis of the substrate.

These results indicate that much of the cellulolytic activity of the original culture filtrate resided in the protein-containing, phthalate-free, rectangular crystals. Further work is in progress to determine the purity and characteristics of these crystals.

<sup>1</sup> Present address: School of Chemical and Metallurgical Engineering, Purdue University, Lafayette, Indiana.