

## A Novel Nonreceptor Tyrosine Kinase, Srm: Cloning and Targeted Disruption

NAOHIRO KOHMURA,<sup>1,2†</sup> TAKESHI YAGI,<sup>1†</sup> YASUHIRO TOMOOKA,<sup>3‡</sup> MITSURU OYANAGI,<sup>4</sup>  
RYO KOMINAMI,<sup>4</sup> NAOKI TAKEDA,<sup>1§</sup> JOE CHIBA,<sup>2</sup> YOJI IKAWA,<sup>1,5</sup> AND SHINICHI AIZAWA<sup>1\*</sup>

Laboratory of Molecular Oncology<sup>1</sup> and Cell Biology,<sup>3</sup> Tsukuba Life Science Center, Institute of Physical and Chemical Research, Riken, Tsukuba, Ibaraki 305, Laboratory of First Biochemistry, Niigata University School of Medicine, Niigata,<sup>4</sup> Department of Biological Science and Technology, Science University of Tokyo, Noda, Chiba,<sup>2</sup> and Department of Biochemistry, Tokyo Medical and Dental University School of Medicine, Tokyo 113,<sup>5</sup> Japan

Received 29 March 1994/Returned for modification 17 May 1994/Accepted 5 July 1994

**We have isolated a novel nonreceptor tyrosine kinase, Srm, that maps to the distal end of chromosome 2. It has SH2, SH2', and SH3 domains and a tyrosine residue for autophosphorylation in the kinase domain but lacks an N-terminal glycine for myristylation and a C-terminal tyrosine which, when phosphorylated, suppresses kinase activity. These are structural features of the recently identified Tec family of nonreceptor tyrosine kinases. The Srm N-terminal unique domain, however, lacks the structural characteristics of the Tec family kinases, and the sequence similarity is highest to Src in the SH region. The expression of two transcripts is rather ubiquitous and changes according to tissue and developmental stage. Mutant mice were generated by gene targeting in embryonic stem cells but displayed no apparent phenotype as in mutant mice expressing Src family kinases. These results suggest that Srm constitutes a new family of nonreceptor tyrosine kinases that may be redundant in function.**

A rapidly increasing number of nonreceptor protein tyrosine kinases (NR-PTKs) have been identified recently with the aid of PCR and other techniques (18, 27, 34, 74). Their general structure is characterized not only by the tyrosine kinase catalytic domain but also by the presence of Src homology (SH) domains (32, 49). NR-PTKs can be classified into several families: the Src family (Src, Yes, Fyn, Lyn, Fgr, Lck, Hck, Blk, and Yrk), the Abl family (Abl and Arg), the Fps family (Fps/Fes and Fer/Flk/Tyk3), the Syk family (Syk/PTK72 and Zap-70), the Jak family (Jak1, Jak2, and Tyk2), and the Tec family (Tec, Btk/Emb, and Itk/Tsk/Emt) (8, 18, 19, 23, 24, 27, 28, 37, 51, 62, 65, 66, 68, 71, 73, 75, 81). In addition, there exist several NR-PTKs, such as Csk (44) and Fak (17, 60), for which homologs are not identified or that may not constitute a family; Fak is a unique NR-PTK that has no SH2, SH2', or SH3 domain. Some of the NR-PTKs (Src, Yes, Fyn, Abl, Arg, Fer, Jak1, Jak2, Tyk2, Csk, and Fak) are expressed ubiquitously, while others are more restricted. For example, the expression of each member of the Src family is rather unique among hematopoietic cells, and Lck, Hck, and Blk expression is restricted to hematopoietic cells (11, 24, 39, 50, 84). The *fps*, *syk*, *zap-70*, *tec*, *btk*, and *itk* genes are also restricted to a subset of hematopoietic cells (8, 12, 23, 37, 62, 66, 68, 81).

It is believed that Src family kinases locate to the inner surface of the plasma membrane through myristyl residues at

their N-terminal glycines and associate with cell surface receptors, thereby transducing signals brought about by specific ligand binding. This has been demonstrated in the association of Lck with CD4, CD8 (72), and the interleukin-2 receptor  $\beta$  chain (20) and of Fyn with the T-cell receptor-CD3 complex (59) and the immunoglobulin receptor complex (5), with which Lyn and Blk are also reported to associate (5, 82). On the other hand, some NR-PTKs function as essential regulators of Src family kinases or as the second transducers of signals via Src family kinases. For example, Csk uniquely phosphorylates the tyrosine at the C-terminal end of Src family kinases, thereby suppressing their activity (45, 47). Fak is activated by Src family kinases (16) and play roles in focal adhesion, possibly regulating the cytoskeletal architecture (6). Syk or Zap-70 associates with an immunoglobulin receptor complex or a T-cell receptor-CD3 complex, respectively, and the association is likely to be regulated by Src family kinases (8, 28).

To define genes that regulate growth and differentiation of neuroepithelial cells, one of us has developed a culture of neuroepithelial cells from midgestation stages of embryos; they divide continuously, segregate into a variety of neurons and glial cells, and produce neural tube-like structures when placed in collagen gels (31, 67, 69). We have screened for new NR-PTKs in these cells. Coincidental production of mutant mice by gene targeting in mouse embryonic stem (ES) cells (77, 80) is our strategy to assess their functions in vivo. Here, we describe a novel NR-PTK gene named *srm* (Src-related kinase lacking C-terminal regulatory tyrosine and N-terminal myristylation sites) and mutant mice lacking *srm*. The structural features of Srm as well as lack of apparent phenotype in the mutant mice suggest that Srm may be a member of a new family of NR-PTKs that are redundant in function.

### MATERIALS AND METHODS

**PCR for tyrosine kinases in NPC cells.** Total RNAs were isolated from neural precursor (NPC) cells as described pre-

\* Corresponding author. Present address: Laboratory of Morphogenesis, Institute of Molecular Embryology and Genetics, Kumamoto University School of Medicine, 2-2-1 Honjo, Kumamoto 860, Japan.

† Present address: Department of Neurobiology and Behavioral Genetics, National Institute for Physiological Sciences, Myodaiji, Okazaki 444, Japan.

‡ Present address: Department of Biological Science and Technology, Science University of Tokyo, Yamazaki, Noda City, Chiba 278, Japan.

§ Present address: Laboratory of Morphogenesis, Institute of Molecular Embryology and Genetics, Kumamoto University School of Medicine, 2-2-1 Honjo, Kumamoto 860, Japan.

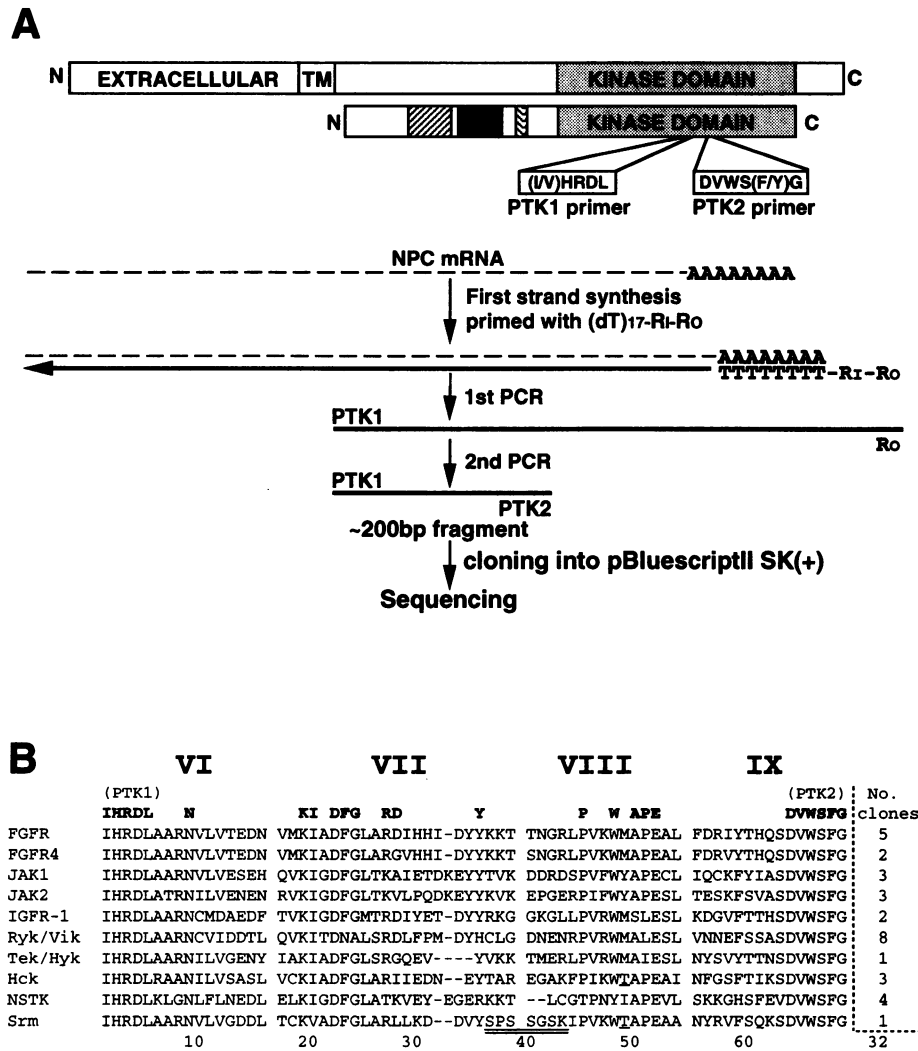

FIG. 1. Identification of PTKs that are expressed in NPC cells. (A) Strategy. PTK1 and PTK2 are degenerate primers that correspond to amino acid sequences conserved in the kinase domain of PTKs. Reverse transcription was performed with the  $(dT)_{17}$ -R<sub>i</sub>-R<sub>O</sub> primer to perform 3' RACE (Fig. 2A) (14). The first PCR was done with PTK1 and R<sub>O</sub> primers, and the second PCR was done with PTK1 and PTK2 primers. Amplified fragments of about 200 bp were cloned into BSK, and sequence analyses were performed on 34 independent clones. TM, transmembrane. (B) Alignment of deduced amino acid sequences encoded in the amplified fragments. The number of individual isolates is shown at the right. Roman numerals indicate the conserved subdomain nomenclature devised by Hanks et al. (18). Conserved amino acids are shown in boldface. The amino acid sequence to isolate the 3' cDNA end (Fig. 2A) is double underlined. The threonine residues conserved in the kinase domain of Src family kinases, Abl family kinases, and Csk are underlined.

viously (58); the NPC cells used in this study were cultured from heads of 10-day embryos (31). The first-strand cDNA was synthesized, using 5  $\mu$ g of total RNAs, by using reverse transcriptase (SuperScript; Bethesda Research Laboratories [BRL]) primed with  $(dT)_{17}$ -R<sub>i</sub>-R<sub>O</sub> (14) at 41°C for 2 h. The products were diluted 50-fold with Tris-EDTA (pH 8.0). Five microliters of this first-strand cDNA dilution was subjected as a template to the first PCR in 50  $\mu$ l of reaction mixture containing 0.2 mM each deoxynucleoside triphosphate, 1.5 mM MgCl<sub>2</sub>, 10 mM Tris-HCl (pH 8.3), 50 mM KCl, 0.001% gelatin, 25 pmol of R<sub>O</sub> primer (5'-AAGGATCCGTCGACATC-3'), 25 pmol of PTK1 primer [5'-CGGATCCAC(A/C)G(A/C/G/T)GA(C/T)(C/T)T-3'], and 2.5 U of *Taq* DNA polymerase (Ampli*Taq*; Perkin-Elmer). The amplifications were performed for 30 cycles; each cycle consisted of 45 s of denaturation at 94°C, 25 s of annealing at 50°C, and 3 min of

elongation at 72°C. The amplified products were diluted 20-fold with deionized water and, using 1  $\mu$ l, the second PCR was performed with the PTK1 primer and PTK2 primer [5'-CT(G/A)CA(G/C)ACCAGGA(A/T)ACCTTAAGG-3']. PCR products of about 200 bp thus generated were digested with *Bam*HI and *Eco*RI and cloned into pBluescriptII SK(+) (BSK).

**DNA sequencing.** DNAs were sequenced by the dideoxy-chain termination method, using the ABI *Taq* dye-primer cycle sequencing kit. The analyses were done with an ABI model 373A automatic DNA sequencer.

**3'RACE.** One microliter of the 20-fold dilution of the first PCR reaction mixture that was amplified in the kinase domain as described above was used as a template in the second amplification by 3'RACE (rapid amplification of 3' cDNA ends) with the 20-mer oligonucleotide primer corresponding to

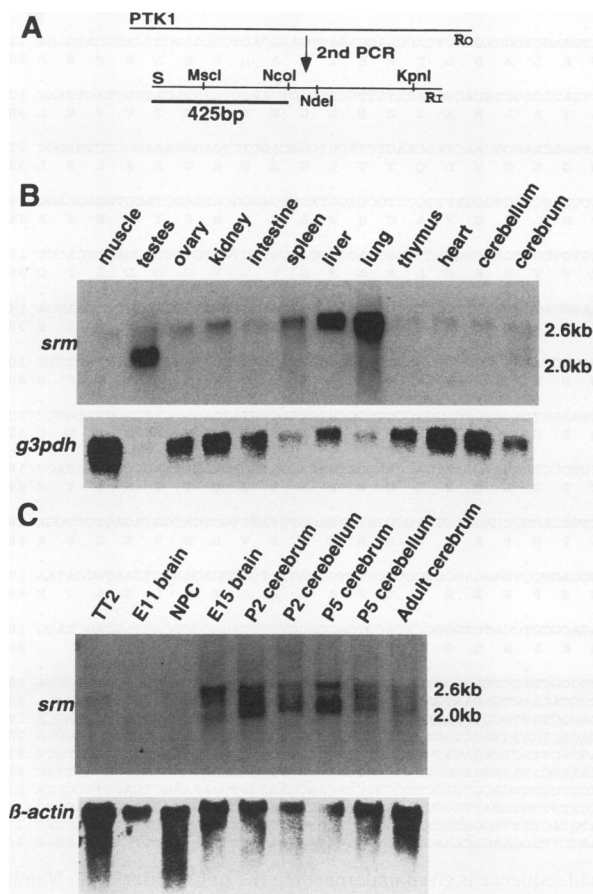

FIG. 2. Northern blot analysis of *srm* expression. (A) Identification of the 3' cDNA end by 3' RACE. The second PCR was performed with primers S and R<sub>1</sub> on the first-PCR product shown in Fig. 1A. The 425-bp fragment from the 5' end to the *Nco*I site of this product was used as a probe for Northern blot analysis after random priming. (B) *srm* expression in adult mouse tissues. Five micrograms of poly(A)<sup>+</sup> RNA from each tissue of a 3.5-month-old mouse was loaded in each lane. The lower panel represents the same Northern blot hybridized with a *g3pdh* cDNA probe. (C) *srm* expression in brain at several developmental stages. Four micrograms of poly(A)<sup>+</sup> RNAs was loaded in each lane. The lower panel shows the same Northern blot hybridized with a  $\beta$ -actin cDNA probe. The sizes of *srm* mRNAs were determined by using an RNA ladder marker (BRL). TT2, ES cells established from an embryonic day 4 blastocyst (80); NPC, NPC cells cultured from heads of 10-day embryos (31).

the amino acid sequence SPSSGSK (5'-TCCCCA AGCAGT GGCTCCAA-3') and the R<sub>1</sub> primer (5'-GACATCGATAAT ACGAC-3'). The conditions were as described above except that the annealing step performed at 55°C.

**Northern (RNA) blot analysis.** Total RNAs were isolated from tissues and cultured cells as described previously (58). Poly(A)<sup>+</sup> RNAs were prepared by using oligo(dT)-cellulose columns (BRL), electrophoresed through a 1% agarose gel containing 2.2 M formaldehyde, and transferred to nylon membranes (GeneScreen; Du Pont). Hybridization was carried out in a solution containing 50% deionized formamide, 1% sodium dodecyl sulfate (SDS), 5 $\times$  SSPE (1 $\times$  SSPE is 150 mM NaCl, 10 mM NaH<sub>2</sub>PO<sub>4</sub>H<sub>2</sub>O, and 1 mM EDTA [pH 7.4]), 10% dextran sulfate, and 5 $\times$  Denhardt's solution (1 $\times$  Denhardt's solution is 0.02% Ficoll, 0.02% polyvinylpyrrolidone, and

0.02% bovine serum albumin) with random-primed probes indicated in the text at 42°C for 24 h. The membranes were washed in 2 $\times$  SSPE twice at room temperature, in 2 $\times$  SSPE-2% SDS twice at 65°C, and in 0.1 $\times$  SSPE once at room temperature and were exposed to X-ray films at -70°C.

**Library screening for cDNA.** A mouse lung cDNA library (CLML1046b; Clontech) was probed with the 425-bp fragment from the 5' end to the *Nco*I site of the 3' RACE product (see Fig. 2A). Hybridization was carried out at 42°C in a solution containing 50% formamide, 4 $\times$  SSC (1 $\times$  SSC is 0.15 M NaCl plus 0.015 M sodium citrate), 50 mM N-2-hydroxyethylpiperazine-N'-2-ethanesulfonic acid (HEPES; pH 7.0), 10 $\times$  Denhardt's solution, and 100  $\mu$ g of salmon testis DNA (Sigma) per ml for 16 h. Stringency of the final wash was 0.2 $\times$  SSC-0.1% SDS at 55°C. The recombinant DNAs of a positive phage were digested with *Eco*RI, and the cDNA insert was subcloned into BSK. Deletion mutants for sequencing were prepared by size-fractionated unidirectional deletion (22) on both strands through the entire cDNA.

**Chromosome mapping.** The chromosomal localization of the *srm* gene was determined by using intersubspecific backcross progeny as described by Hayashi et al. (21). In brief, several primers in sequences of the *srm* gene were tested as to whether they yielded polymorphisms between C57BL/6 and MSM strains of mice in PCR assays. A primer set, 5'-ACG AGAGCCAGCAGTTTCCT-3' and 5'-GTCCCCTAAAAGT ACATAGCA-3', complementary to the 3' noncoding region gave bands with similar mobilities at about 160 bp for C57BL/6 and MSM DNAs, but it yielded an extra band in their F<sub>1</sub> DNAs which was probably due to heteroduplex formation. The primers were then used for genotyping 106 backcross mice that were obtained by mating (C57BL/6  $\times$  MSM)F<sub>1</sub> females to MSM males. The MSM strain originates from Japanese wild mice (*Mus musculus molossinus*) (3). In parallel, the backcross mice were typed with 67 published markers (9, 10) and 52 newly isolated markers (unpublished data).

**Construction of gene targeting vector.** A mouse genomic DNA was cloned by using the 425-bp fragment of the 3' RACE product as a probe from an EMBL3 BALB/c mouse genomic DNA library (Clontech). After the restriction map was made, the 870-bp *Kpn*I fragment (see Fig. 5A) was found to hybridize with the 425-bp fragment. The *Kpn*I fragment and the adjacent *Apa*I-*Kpn*I fragment (see Fig. 5A) were subcloned into BSK and sequenced; exon-intron boundaries were determined by comparing the sequences with those of cDNA. To disrupt the *srm* gene, the *lacZ-neo*<sup>r</sup> cassette was inserted into *Eco*571 site in the kinase domain (see Fig. 5A); the cassette was composed of *trpS-lacZ*, the simian virus 40 small t intron, a polyadenylation signal, and the *neo*<sup>r</sup> gene; the *neo*<sup>r</sup> gene was derived from PGKneo, which has the mouse *pgk-1* gene promoter, with deletion of polyadenylation signal (2). For negative selection to enrich homologous recombinants, the diphtheria toxin A-fragment cassette was added at the *Nde*I site in the last exon (77); the cassette was composed of an mRNA-destabilizing AT-rich sequence (61), minute virus of mice pausing signal (52), and BSK. In the targeting vector thus produced, pSGT, the length of homologous region was 7.7 kb at the 5' side of the *lacZ-neo*<sup>r</sup> cassette insert and 1.6 kb at the 3' side.

***srm* targeting in ES cells.** The ES cells used in this study were TT2 cells from an F<sub>1</sub> blastocyst from a cross between C57BL/6 and CBA/JNcrj mice (80); they were cultured in high-glucose Dulbecco's modified Eagle's medium (BRL) supplemented with 20% fetal bovine serum (CELLECT Gold; Flow Laboratories), 1 $\times$  nonessential amino acids (Flow Laboratories), 1 mM sodium pyruvate, 0.1 mM 2-mercaptoetha-

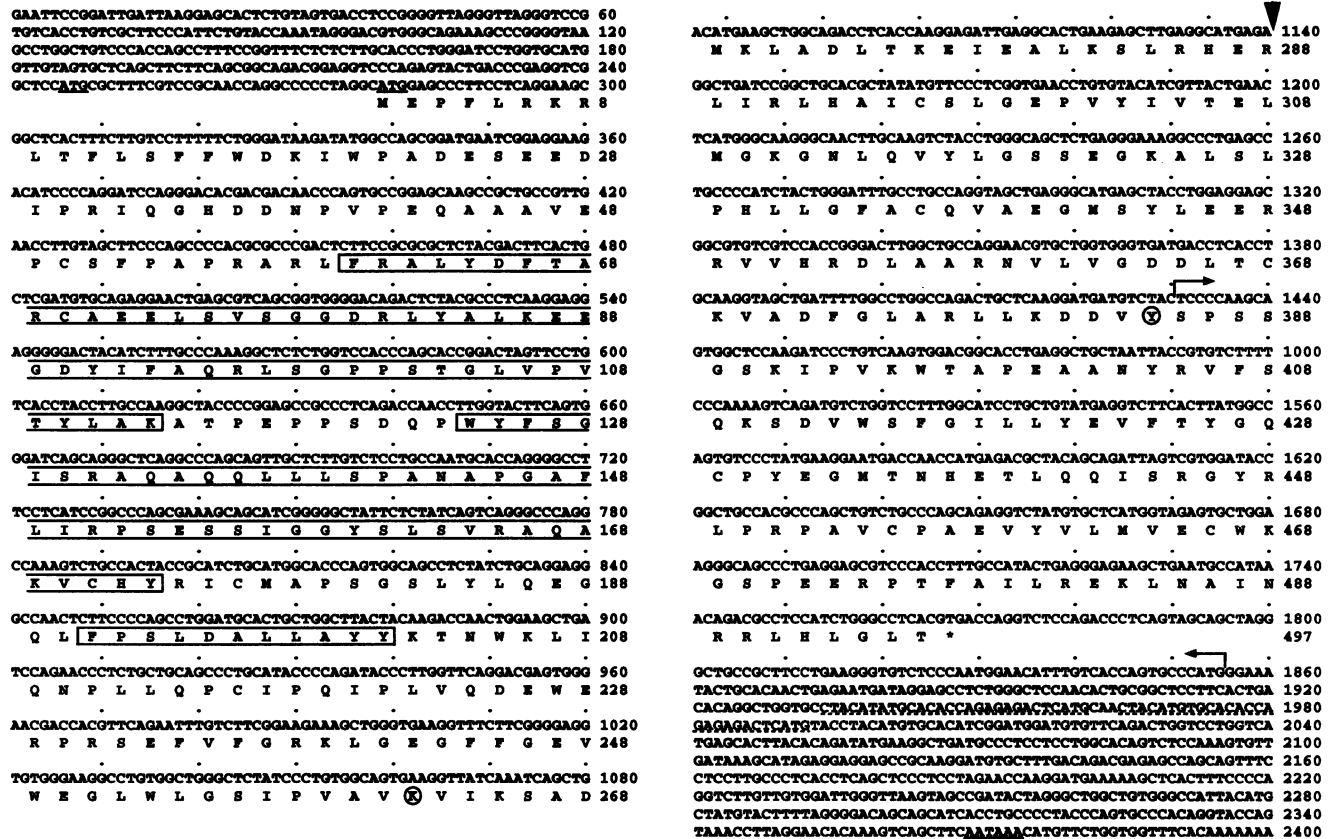

FIG. 3. Nucleotide sequence of the murine *sm* gene. The deduced amino acid sequence is given underneath in the single-letter code. Numbers indicate nucleotide positions from the 5' end of the cDNA and amino acid positions from the N-terminal end. SH3, SH2, and SH2' regions are boxed. Two potential in-frame ATG start codons are underlined. A polyadenylation signal (AATAAA) is double underlined. A lysine residue for an ATP binding site and a tyrosine residue for autophosphorylation are circled. The DNA fragment between two arrows is the probe used for Northern blot analysis in Fig. 2B and C and for cDNA library screening. The arrowhead indicates the position of the *lacZ-neo<sup>r</sup>* cassette insertion for targeted disruption. Tandemly repeated sequences in the 3' noncoding region are underlined by dashes.

nol, and 1,000 U of leukemia inhibitory factor (AMRAD) per ml on mitomycin-treated embryonic fibroblasts from YF4 mice carrying the *neo<sup>r</sup>* gene (80);  $10^7$  TT2 cells were electroporated with 12 nM pSGT linearized by *NotI* digestion, using a Gene Pulser (Bio-Rad) at an electric pulse of 250 V and 960  $\mu$ F. Selection was started 48 h later in medium containing 150  $\mu$ g of G418 (Sigma) per ml. After 7 days of selection, G418-resistant colonies were cloned; two-thirds of each colony was passaged onto 12-well plates containing feeder cells of embryonic fibroblasts, and the rest was subjected to PCR analysis for homologous recombinants as follows. The cell suspensions were pooled for every four clones, and the cell pellets were resuspended in 50  $\mu$ l of water, boiled for 10 min, treated with 5  $\mu$ g of proteinase K at 55°C for 120 min, and boiled again for 10 min. Half of the mixture was used as a template for PCR analyses; the analyses were made with 25 pmol each of two primers, 5'-TTGACGAGTTCTTCTGA-3' and 5'-GACCAG GACCAGTCTGAACACATCCATCCG-3'; the former is located at the 3' terminus of the *neo<sup>r</sup>* gene, and latter is located at the 3' end outside of the targeting vector in the *sm* gene (see Fig. 5A). The clones of the pools that gave an expected amplification of about 1.8 kb were propagated, and each was further analyzed by PCR. The homologous recombinant clones thus identified were further propagated to select the cells frozen and to isolate DNAs. The homologous

nature of the recombination was confirmed by genomic Southern blot analysis.

**Southern blot analysis.** Genomic DNAs were extracted from cells or mouse tail tips by the SDS-proteinase K method (42). Ten micrograms of DNAs was digested with restriction enzymes and separated by electrophoresis in a 0.8% agarose gel. The gels were treated with denaturation buffer (0.5 M NaOH, 1.5 M NaCl) for 45 min and with neutralization buffer (0.5 M Tris-HCl [pH 7.5], 3 M NaCl) for 1 h and then transferred to nitrocellulose membranes (BA85; Schleicher & Schuell). Hybridization was performed with random-primed probes in 50% formamide-4 $\times$  SSC-50 mM HEPES (pH 7.0)-10 $\times$  Denhardt's solution containing 20  $\mu$ g of denatured salmon testis DNA per ml at 42°C for 16 h, followed by washing twice in 2 $\times$  SSC-0.1% SDS at room temperature for 15 min and twice in 0.2 $\times$  SSC-0.1% SDS at 55°C for 30 min. The analyses were performed with several restriction enzymes and probes that correspond to sequences outside and inside of the targeting vector.

**RT-PCR.** Poly(A)<sup>+</sup> RNAs were extracted from livers of wild-type, heterozygous, and homozygous mutant mice. The first-strand cDNAs were synthesized, using 1  $\mu$ g of the poly (A)<sup>+</sup> RNAs, by using reverse transcriptase (SuperScriptII; BRL) with d(T) primer (Pharmacia) in 20- $\mu$ l reaction mixtures. The mixtures were diluted 25-fold with deionized water,

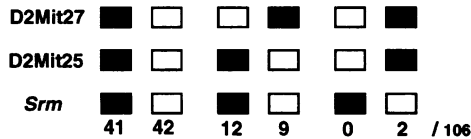

FIG. 4. Position of the *srm* locus on mouse chromosome 2. The distribution of haplotypes for 106 progeny from intersubspecific backcross mice that were obtained by mating (C57BL/6 × MSM)<sub>F1</sub> females to MSM males is shown. The loci monitored in the cross are indicated on the left. Filled squares represent the C57BL/6 allele, and open squares represent the MSM allele. Each column represents the chromosome identified in the progeny. The number of progeny carrying each type of chromosome is listed at the bottom. The primer sequences used are 5'-ACGAGAGCCAGCAGTTTCCT-3' and 5'-GTCCCCTAAAAGTACATAGCA-3', which span a 157-bp region. PCR products were analyzed by 9% polyacrylamide gel electrophoresis.

and 1 μl served as the template in a reverse transcriptase-mediated PCR (RT-PCR). The primers used for the amplification were p1 (5'-ATGGAGCCCTTCCTCAGGAA-3' [nucleotide positions 279 to 298 in Fig. 3]), p2 (5'-TGGTACTTCAGTGGGATCAG-3' [648 to 667]), p3 (5'-TAACCTTCACTGCCACAGGG-3' [1068 to 1049]), p4 (5'-GGTGAGGTCATCACCCACCA-3' [1379 to 1360]), p5 (5'-TGGGAAAAGACACGGTAATTA-3' [1504 to 1484]), p6 (5'-TACTGGTACCTGTGGGCACT-3' [2342 to 2323]), and p7 (5'-TCGTGCTTTACGGTATCGCCGCTCCCGATT-3', located at the 3' terminus of the *neo<sup>r</sup>* gene). The amplifications were performed for 30 cycles; each cycle consisted of 45 s of denaturation at 94°C, 25 s of annealing at 60°C, and 3 min of elongation at 72°C. The reaction products were run on 1% agarose gels, and Southern blot analysis was performed. The probes used were o2 (5'-TGGTACTTCAGTGGGATCAG-3' [648 to 667]), o3 (5'-TTTGCTGCCAGGTAGCTGA-3' [1278 to 1297]), o4 (5'-TCCCAAGCAGTGGCTCCAA-3' [1431 to 1450]), and o5 (5'-GACCAGACCAGTCTGAA CACATCCATCCG-3' [2033 to 2008]).

**Phylogenetic analysis.** The analysis was made with the programs Clustal V, Clust To Tree, and Tree Draw Deck by EMBnet BioInformation Resources (EMBL).

**Nucleotide sequence accession number.** The sequence data have been filed in the GenBank database (accession number D26186).

## RESULTS

### Identification of tyrosine kinases expressed in NPC cells.

The total RNAs from primary cultures of mouse NPC cells from embryonic day 10 (E10) fetal heads (31) were used to identify novel PTKs by PCR (76) (Fig. 1A); the degenerate primers used correspond to the amino acid sequences (I/V)HRDL (PTK1) and DVWS(F/Y)G (PTK2) in the highly conserved subdomains VI and IX in the kinase domain of PTKs (18). The first-strand cDNA was synthesized by reverse transcription using (dT)<sub>17</sub>-R<sub>1</sub>-R<sub>O</sub> as a primer as described by Frohman et al. (14). This was followed by the first PCR with PTK1 and R<sub>O</sub> primers and then by the second PCR with PTK1 and PTK2 primers after dilution. The expected products of about 200 bp in length were cloned into BSK and sequenced.

Sequence analyses of 34 independent clones thus isolated yielded 11 sequences that had significant similarity to sequences of PTKs. One matched the sequence of elongation factor-2, and eight matched sequences of the known PTKs FGFR (38), FGFR4 (48), Jak1 (75), Jak2 (19), IGFI-R (13),

Ryk (26)/Vik (30), Tek (83)/Hyk (25), and Hck (50) (Fig. 1B). Two were novel, and one appeared to be a new Ser/Thr kinase (NSTK in Fig. 1B), resembling the cyclic AMP-dependent protein kinase at the nucleotide level and the protein kinase C family at the amino acid level (53, 70). The other was *Srm*, which is analyzed here in detail; it was obtained as a single clone among 34 clones analyzed. The amino acid sequence of the amplified product predicted *Srm* to be a new Src family tyrosine kinase. All Src family kinases known to date have threonine at amino acid position 49 in Fig. 1B as *Srm* does, while most receptor PTKs have methionine at this position; among NR-PTKs, Abl, Arg, and Csk also have threonine at this position, but others do not. A homology database search indicated that *Srm* had the highest level of homology to Src family kinases.

**Expression pattern of *srm* mRNA.** Using the 20-mer oligonucleotide primer corresponding to the amino acid sequence SPSSGSK (amino acids 37 to 43 in Fig. 1B) and the R<sub>1</sub> primer, 3'RACE was performed on the first-PCR products described above (Fig. 2A). This yielded a 1.0-kb product which corresponded to the 3' terminus of *srm* cDNA containing a polyadenylation site. The 425-bp fragment from the 5' end to the *Nco*I site of the product was then used to examine the tissue distribution of *srm* expression in adult mice by Northern blot analysis (Fig. 2B and C). The fragment can be considered to identify specifically the *srm* transcript, since it gave unique hybridization in Southern blot analysis of genomic DNAs digested with several restriction enzymes. Two sizes of mRNAs, 2.6 and 2.0 kb, were found to be tissue dependent (Fig. 2B). The 2.6-kb product was abundant in lung, liver, spleen, and kidney, but it was ubiquitous in other tissues. The 2.0-kb product was abundant in testes, and it was also found in cerebrum. Figure 2C shows the developmental changes in *srm* expression in brain. It was very low in E11 brain, the 2.6-kb transcript was detected in E15 brain, and the 2.0-kb transcript was found in postnatal brain. Expression of the 2.6-kb mRNA was reduced in postnatal brain, and both transcripts were expressed at low levels in adult brain. The NPC cells with which the *srm* gene was identified and TT2 ES cells that were used for the *srm* gene targeting as described below had very low *srm* expression.

***Srm* is a novel NR-PTK.** Since *srm* expression was highest in lung, a full-length cDNA was isolated from a mouse lung cDNA library. The complete nucleotide sequence extended for 2,400 nucleotides and contained an open reading frame of about 1,500 nucleotides (Fig. 3). Two potential translational initiation ATG codons were present in frame at nucleotide positions 246 and 279. The latter was speculated to be the true initiation site, since it matched strongly the optimal consensus sequence defined by Kozak (33). An open reading frame of 497 amino acid residues is framed by 278 nucleotides of 5' untranslated sequence and 631 nucleotides of 3' untranslated sequence.

Like Src family kinases, *Srm* had kinase (SH1), SH2, SH2', and SH3 domains. It also had lysine for ATP binding and tyrosine for autophosphorylation in the kinase domain. However, contrary to our initial expectation, the sequences had several structural features that were different from those of Src family kinases (see Fig. 7A). All Src family kinases have a glycine residue at the second amino acid of the N-terminal region, myristylation of which serves as an anchor to the inner surface of the plasma membrane. *Srm* did not have this glycine; it did not exist even if the ATG at position 246 was speculated to be the initiation codon, and there were numerous stop codons upstream. In the kinase domain, all Src family kinases have a tyrosine residue close to the C-terminal end that

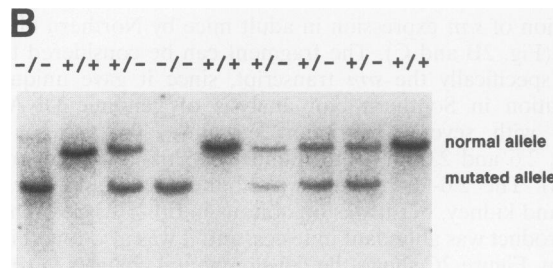
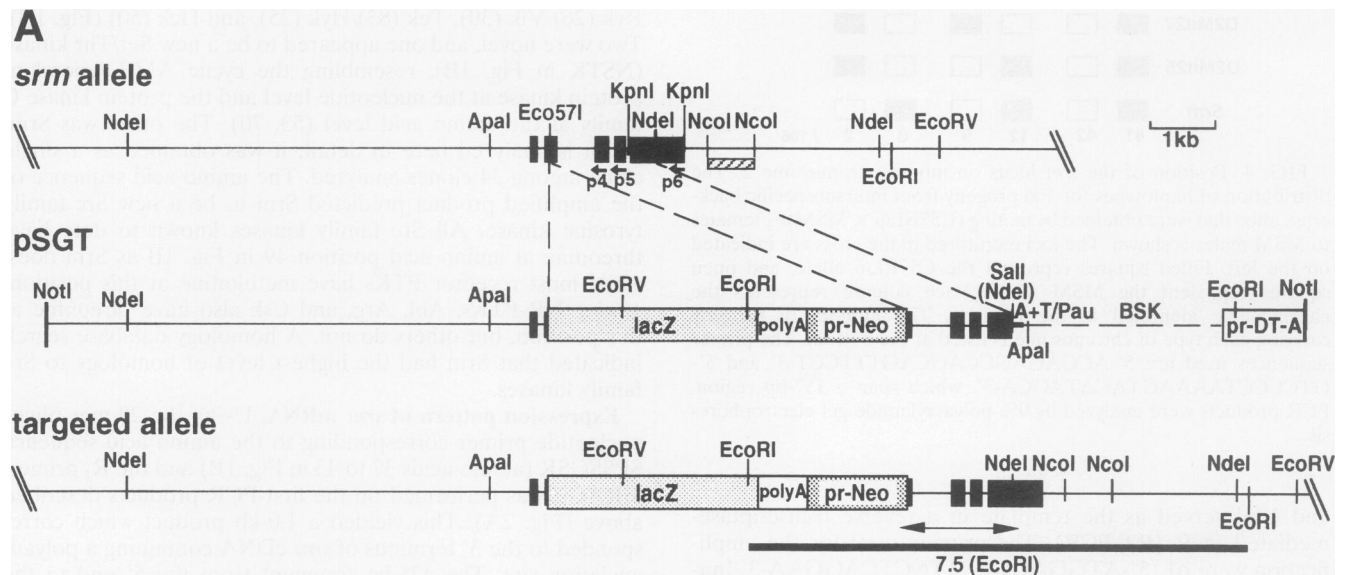

**FIG. 5.** Targeting of the *srn* gene by homologous recombination in ES cells. (A) The genomic structure of the *srn* allele, the targeting vector pSGT, and the predicted structure of the targeted allele after homologous recombination. The homologous recombinants were isolated with the *neo<sup>r</sup>* gene (pr-Neo) for positive selection and the diphtheria toxin A-fragment gene (pr-DT-A) for negative selection, directed by the *pgk-1* gene promoter and MC1 promoter, respectively; A+T/Pau is the mRNA-destabilizing AT-rich sequence and pausing signal of minute virus of mice (77). Closed boxes indicate exons. The probe for Southern blot analysis used in Fig. 5B is shown by a hatched box. The line with arrows at both ends represents the PCR amplification to detect homologous recombinants. There are other, not-yet-identified exons between the 5' *NdeI* and *Eco57I* sites, as well as several other *KpnI*, *NcoI*, and *Eco57I* sites whose locations were also not identified. A solid bar represents the 7.5-kb *EcoRI* fragment diagnostic of homologous recombination in Fig. 5B; the 5' upstream *EcoRI* site in the endogenous *srn* allele was not identified but is located about 15 kb upstream. The locations of primers p4 to p6 for RT-PCR assays in Fig. 6 are also given. (B) Southern blot analysis after *EcoRI* digestion on tail tips of offspring from heterozygous parents. +/+, +/-, and -/- represent wild-type, heterozygous, and homozygous mutant mice, respectively.

corresponds to tyrosine 527 in chicken c-Src and phosphorylation of which suppresses the kinase activity (7), but Srm did not.

**The *srn* gene maps to chromosome 2.** Segregation analysis was performed to map the *srn* gene (21). A primer pair complementary to the 3' noncoding sequence was found to yield a variation in the PCR assay between DNAs from C57BL/6 and MSM strains of mice. Genotyping was made with this primer set on 106 intersubspecific backcross mice between the two strains. The strain distribution pattern was compared with the pattern of 119 anchor loci. Figure 4 summarizes the result of typing the backcross mice. A clear linkage of the *srn* locus was found with a marker, D2Mit25, on chromosome 2 (9, 10). From this haplotype analysis, the most likely order of loci was Cen--D2Mit27--20  $\pm$  3.9 centimorgans-D2Mit25--1.9  $\pm$  1.3 centimorgans-*srn* . . . . Thus, the analysis concludes that the *srn* locus is located 2.1 centimorgans distal to the D2Mit25 locus on chromosome 2 (LOD score, 27.6).

***srn*-deficient mice.** To assess the function of the *srn* gene, mutant mice were generated by gene targeting in ES cells. Figure 5A shows the targeting vector pSGT, in which a

*lacZ-neo<sup>r</sup>* cassette was placed at the *Eco57I* site in the exon encoding the kinase domain IV. The *lacZ* gene was fused in frame to the 5' side of the *srn* gene. The *neo<sup>r</sup>* gene for positive selection was directed with a *pgk-1* gene promoter and lacked a polyadenylation signal, and the diphtheria toxin A-fragment gene was used for negative selection to enrich for homologous recombinants (77). The targeting vector pSGT was introduced into TT2 ES cells from a (C57BL/6  $\times$  CBA/JNCrj)F<sub>1</sub> embryo (80) by electroporation. The frequency of homologous recombinants was 7 of 160 G418-resistant clones when assessed by PCR analysis (data not shown). The homologous nature of the recombinations in these clones was confirmed by Southern blot analysis with several restriction enzymes and probes that correspond to sequences either inside or outside of the targeting vector (Fig. 5B). The five homologous recombinant clones were injected into ICR eight-cell stage embryos, and three clones (AD1, DA4, and DB4) generated chimeras with a coat color which was exclusively TT2-derived agouti. These chimeras were mated with C57BL/6 females to obtain heterozygous mice. Initially we expected to examine *srn* expression in detail by  $\beta$ -galactosidase staining of heterozygous embryos and mice,

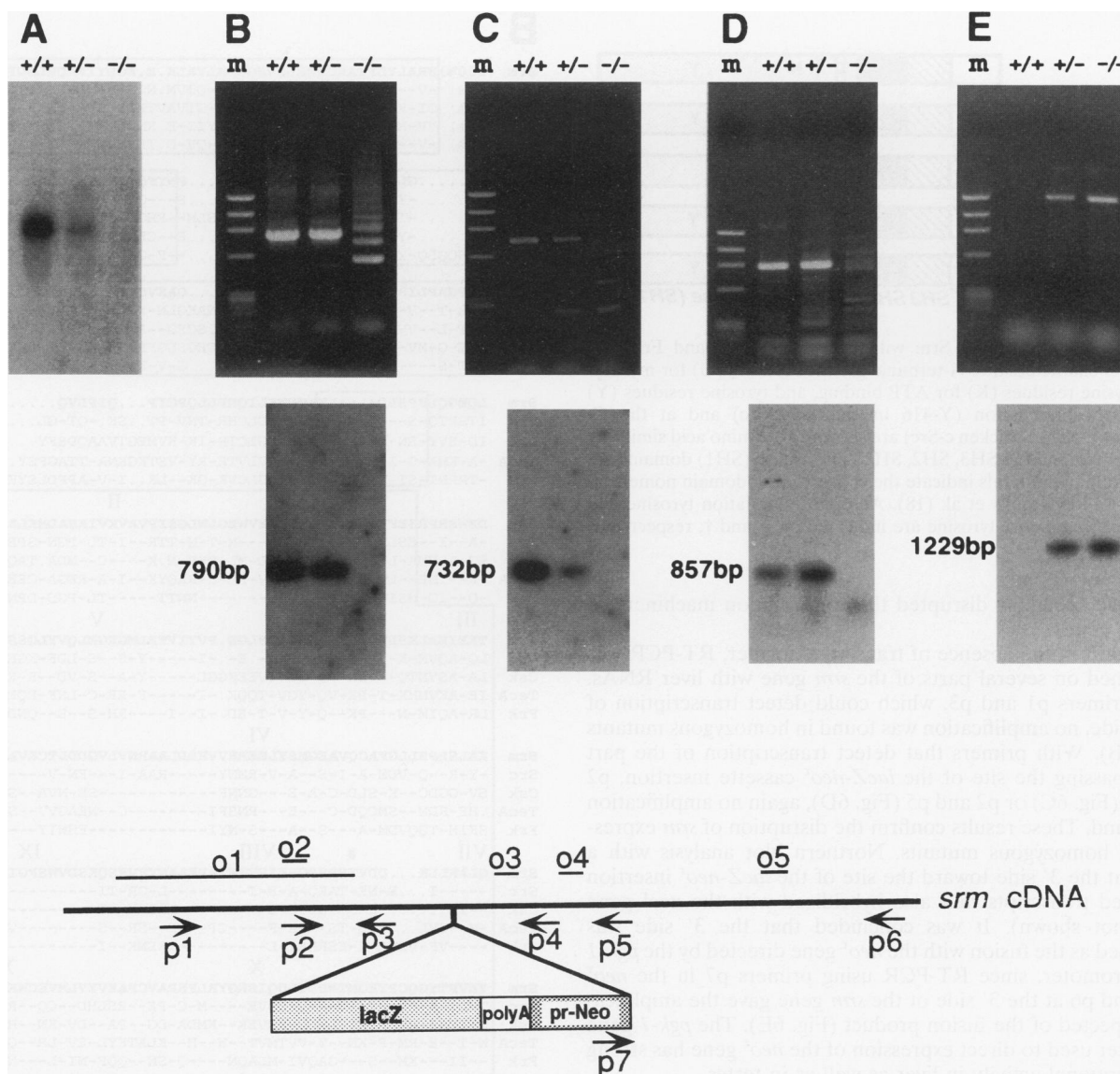

FIG. 6. Disruption of the *srm* gene in mutant mice. Shown are Northern blot analysis (A) and RT-PCR assays (B to E) of liver poly(A)<sup>+</sup> RNAs. Northern blot analysis was performed with the o1 probe (*Bam*HI-*Pst*I fragment; nucleotide positions 168 to 836 in Fig. 3), and RT-PCR assays were performed with p1 and p3 primers to detect transcription of the 5' side (B), with p2 and p4 primers (C) or p2 and p5 primers (D) to detect transcription of the part encompassing the site of *lacZ-neo*<sup>r</sup> cassette insertion, and with p7 and p6 primers to detect the fusion transcription between the *neo*<sup>r</sup> gene and 3' side (E). The upper blots in panels B to E show the ethidium bromide staining of the amplified products, and the lower blots show hybridization with probes o2 (B), o3 (C), o4 (D), and o5 (E). The position of each primer and probe and the insertion site of the *lacZ-neo*<sup>r</sup> cassette in the *srm* cDNA are indicated below. The exons in which p4, p5, and p6 are located are indicated in Fig. 5A. m, *Hae*III-digested  $\phi$ X174 DNA size markers (1,353, 1,078, 872, 603, and 310 bp); +/+, wild-type mice; +/-, heterozygous mice; -/-, homozygous mutant mice.

but no staining could be found even in lungs and testes that had high mRNA expression.

The heterozygous female and male mice were crossed to examine any phenotype caused by *srm* deficiency. Among the total of 106 offspring analyzed, 27 were homozygous mutant, as expected from Mendelian transmission (Fig. 5B). The homozygous mutant mice were apparently normal; the external appearance of the whole body and each organ, body weight, and general behavior were indistinguishable from those of normal mice. Both homozygous mutant females and males yielded offspring normally. In addition, no abnormality was found histologically in lung, liver, spleen, brain, or testis samples that had significant *srm* mRNA expression.

The lack of apparent abnormality in homozygous mutants raised the question of whether the *srm* gene was indeed disrupted by the targeting. Northern blot analysis using a probe located at the 5' side toward the site of the *lacZ-neo*<sup>r</sup> insertion, however, did not detect the presence of any transcript in liver which had high *srm* expression (Fig. 6A). This indicates no transcription of this part even in fusion with the *lacZ* gene, contrary to our initial expectation. Indeed, no transcripts either of the fusion product or of *lacZ* itself were detected with *lacZ* as a probe (data not shown), explaining why no  $\beta$ -galactosidase staining could be observed in mutant embryos or adult tissues. The insertion of the *lacZ-neo*<sup>r</sup> cassette into the kinase domain

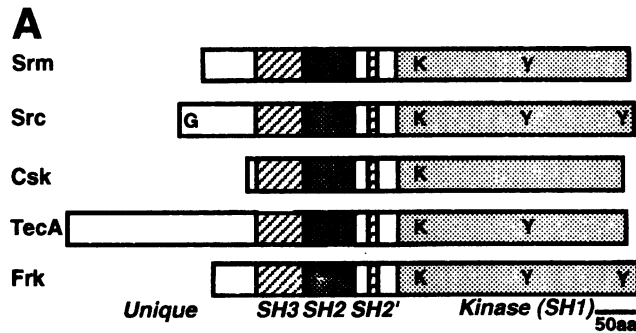

FIG. 7. Comparison of Srm with Src, Csk, TecA, and Frk. (A) Structural characteristics. N-terminal glycine residues (G) for myristylation, lysine residues (K) for ATP binding, and tyrosine residues (Y) for autophosphorylation (Y-416 in chicken c-Src) and at the C-terminus (Y-527 in chicken c-Src) are shown. (B) Amino acid similarity in the SH region. The SH3, SH2, SH2', and kinase (SH1) domains are boxed. Roman numerals indicate the conserved subdomain nomenclature devised by Hanks et al. (18). Autophosphorylation tyrosine and C-terminal regulatory tyrosine are indicated by # and †, respectively.

may have somehow disrupted the transcription machinery of the *src* gene.

To confirm the absence of transcripts further, RT-PCR was performed on several parts of the *src* gene with liver RNAs. With primers p1 and p3, which could detect transcription of the 5' side, no amplification was found in homozygous mutants (Fig. 6B). With primers that detect transcription of the part encompassing the site of the *lacZ-neo<sup>r</sup>* cassette insertion, p2 and p4 (Fig. 6C) or p2 and p5 (Fig. 6D), again no amplification was found. These results confirm the disruption of *src* expression in homozygous mutants. Northern blot analysis with a probe at the 3' side toward the site of the *lacZ-neo<sup>r</sup>* insertion displayed transcripts that also hybridized with the *neo<sup>r</sup>* gene (data not shown). It was concluded that the 3' side was expressed as the fusion with the *neo<sup>r</sup>* gene directed by the *pgk-1* gene promoter, since RT-PCR using primers p7 in the *neo<sup>r</sup>* gene and p6 at the 3' side of the *src* gene gave the amplification expected of the fusion product (Fig. 6E). The *pgk-1* gene promoter used to direct expression of the *neo<sup>r</sup>* gene has strong transcriptional activity in liver as well as in testes.

## DISCUSSION

There are several known families of NR-PTKs that have SH2, SH2', and SH3 domains, but Srm appears to constitute a new family (Fig. 7A). Srm diverges from the Src family kinases in the absence of a glycine for myristylation at the N-terminal end and of a negative tyrosine at the C-terminal end, and it resembles Csk, which uniquely phosphorylates the negative tyrosine of Src family kinases (45, 47). However, Csk does not have the tyrosine in the middle of the kinase domain that corresponds to Tyr-416 in chicken c-Src which activates the kinase by autophosphorylation, while Srm does have this tyrosine. In addition, the amino acid sequence similarity of Srm to rat Csk was only 56% in the SH region that includes the kinase, SH2, SH2', and SH3 domains (44) (Fig. 7B). In these structural features, Srm appears to belong to the recently identified Tec family of NR-PTKs, whose members include Tec, Btk/Emb, and Itk/Tsk/Emt (23, 37, 62, 68, 81). Expressions of the genes of this family is restricted to a subset of hematopoietic cells, and mutations in the *btk* gene are involved in human X-linked agammaglobulinemia (51, 68, 73). How-

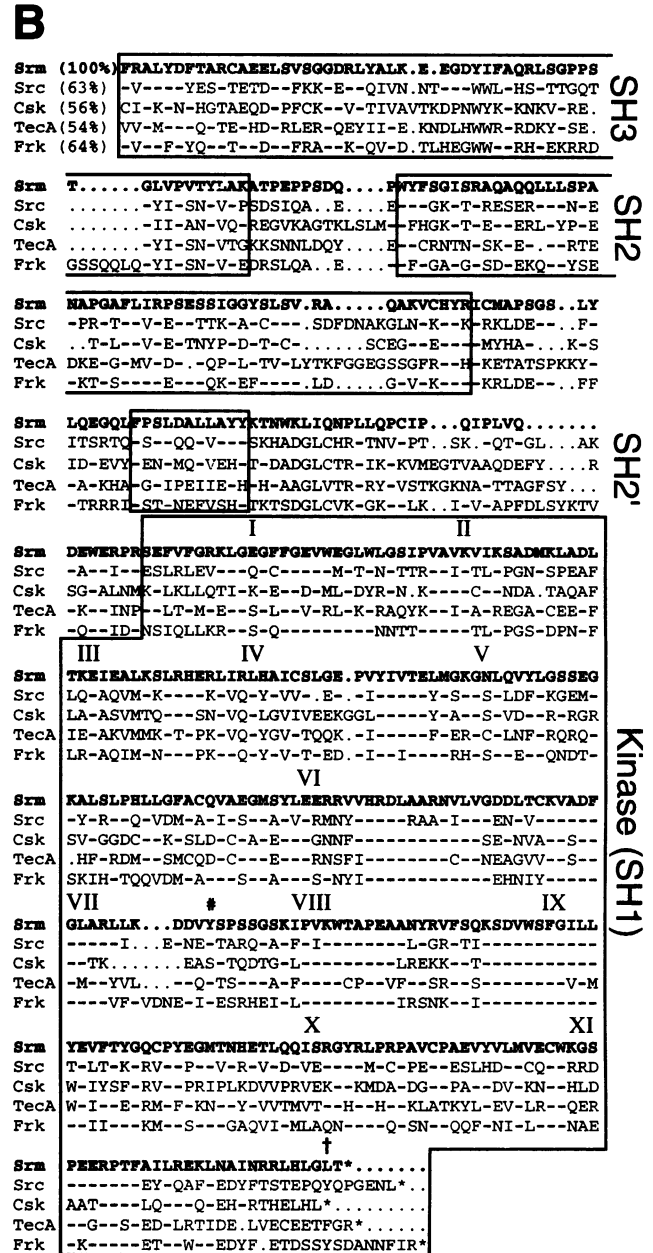

ever, members of this family of NR-PTKs all have long (about 200 amino acid residues) N-terminal unique domains, are rich in basic amino acids, and have a linker sequence rich in proline in front of the SH3 domain. The amino acid similarity in this unique region is quite high among the family members. However, the length of the N-terminal region of Srm is only 59 amino acids, similar to those of Src family kinases, and the N-terminal unique region of Srm does not have other features of Tec family kinases; no significant homology was found with Tec family kinases in this region. Furthermore, the amino acid similarity between Srm and Tec family kinases was in the range of about 53 to 55% in the SH region (Fig. 7B).

Figure 8 shows a phylogenetic tree of NR-PTKs deduced from the overall amino acid sequence similarity (57). In the SH region, Src family kinases are one of the two kinds of kinases



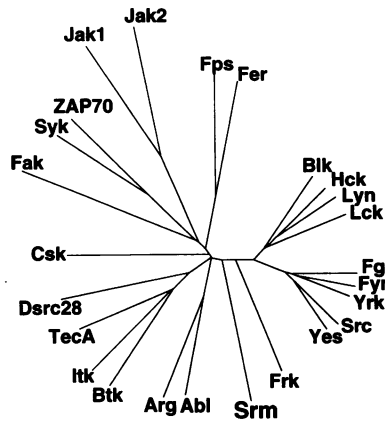

FIG. 8. Phylogenetic tree of NR-PTKs deduced from the amino acid sequence similarity (57).

most homologous to *Srm*: mouse *Src* is 63% (40) and mouse *Lck* is 62% (39) homologous to *Srm*. Among *Src* family kinases, *Src* is most similar to *Yes* (92% similarity) and least similar to *Lck* (74% similarity). The other tyrosine kinase that had the highest similarity to *Srm* is *Frk*, recently identified in humans (64% similarity in the SH region) (35). *Frk* has no glycine for myristylation but otherwise has the same structural features as *Src* family kinases, being 71% similar to *Src* in the SH region.

Although the expression of a gene at a certain site and at a certain stage does not necessarily mean that the gene is playing a role there, the expression data suggest that functions of the *srn* gene may be rather ubiquitous. In the neural system, it is most likely to play roles in establishment of the system rather than in initiation of neurogenesis or in adult brain functions. The isolation of the *srn* gene from embryonic NPC cells may be just coincidental. Unexpectedly, the mutant mice did not reveal any functions of the *srn* gene. The absence of phenotype in the targeted mice, however, does not mean that the gene is not playing a role *in vivo*. An increasing number of mutant mice have been generated by gene targeting in ES cells, and their phenotypes are generally much more limited than those expected from expression patterns and/or *in vitro* experiments. For example, contrary to the wide belief about the roles of tenascin in morphogenesis, tenascin-deficient mice did not display any obvious phenotype (56). The findings in these mice may not mean that tenascin does not have functions *in vivo*. Rather, other tenascin-like molecules such as restriction (46) and major histocompatibility complex-tenascin (41), which were recently identified, or other extracellular matrix components may compensate for the lack of tenascin, leaving subtle defects that could not be identified. The expression of a number of *Src* family kinases starts at the neurula stage during development (78), while mice lacking a single *Src* family kinase (such as mice deficient in *Src*, *Fyn*, *Yes*, *Lck*, *Fgr*, or *Hck*) (1, 15, 36, 43, 62, 63, 79) could develop normally. However, the necessity of the regulated activity of *Src* family kinases for neurulation was demonstrated in mice lacking *Csk* (45, 63). Furthermore, though *myf-5*- or *myoD*-deficient mice did not display any abnormality in muscle differentiation (4, 54), mice lacking both genes had clear defects in muscle differentiation (55). Thus, the absence of an apparent defect in *srn*-deficient mice and the uniqueness of the structural features of the gene may suggest that *srn* encodes a new family of NR-PTKs that are redundant in function.

#### ACKNOWLEDGMENTS

This work was supported in part by grants-in-aid from the Science and Technology Agency and the Ministry of Education, Science and Culture of Japan.

#### REFERENCES

- Appleby, M. W., J. A. Gross, M. P. Cooke, S. D. Levin, X. Qian, and R. M. Perlmutter. 1992. Defective T cell receptor signaling in mice lacking the thymic isoform of p59<sup>lck</sup>. *Cell* 70:751-763.
- Boer, P. H., H. Potten, C. N. Adra, K. Jardine, G. Mullhofer, and M. W. McBurney. 1990. Polymorphisms in the coding and non-coding regions of murine *Pgk-1* alleles. *Biochem. Genet.* 28:299-308.
- Bonhomme, F., and J.-L. Guenet. 1989. The wild house mouse and its relatives, p. 649-662. In M. P. Lyon and A. G. Searle (ed.), *Genetic variants and strains of the laboratory mouse*. Oxford University Press, New York.
- Braun, T., M. A. Rudnicki, H. H. Arnold, and R. Jaenisch. 1992. Targeted inactivation of the muscle regulatory gene *Myf-5* results in abnormal rib development and perinatal death. *Cell* 71:369-382.
- Burkhardt, A. L., M. Brunswick, J. B. Bolen, and J. J. Mond. 1991. Anti-immunoglobulin stimulation of B lymphocytes activates src-related protein tyrosine kinases. *Proc. Natl. Acad. Sci. USA* 88:7410-7414.
- Burridge, K. T., C. E. Turner, and L. H. Romer. 1992. Tyrosine phosphorylation of paxillin and pp125<sup>FAK</sup> accompanies cell adhesion to extracellular matrix: a role in cytoskeletal assembly. *J. Cell Biol.* 119:893-903.
- Cantley, L. C., K. R. Auger, C. Carpenter, B. Duckworth, A. Graziani, R. Kapeller, and S. Soltoff. 1991. Oncogenes and signal transduction. *Cell* 64:281-302.
- Chan, A. C., M. Iwashima, C. W. Turck, and A. Weiss. 1992. ZAP-70: a 70 kd protein-tyrosine kinase that associates with the TCR  $\zeta$  chain. *Cell* 71:649-662.
- Cornell, R. J., T. J. Altman, C. M. Hearne, and J. A. Todd. 1991. The generation of a library of PCR-analyzed microsatellite for genetic mapping of the mouse genome. *Genomics* 10:874-881.
- Dietrich, W., H. Katz, S. E. Lincoln, H. S. Shin, J. Friedman, N. Dracopoli, and E. S. Lander. 1992. A genetic map of the mouse suitable for typing intraspecific crosses. *Genetics* 131:423-447.
- Dymecki, S. M., J. E. Niederhuber, and S. V. Desiderio. 1990. Specific expression of tyrosine kinase, *blk*, in B lymphoid cells. *Science* 247:332-336.
- Feldman, R. A., J. L. Gabilove, J. P. Tam, M. A. Moore, and H. Hanafusa. 1985. Specific expression of the human cellular *fps/fes*-encoded protein NCP92 in normal and leukemic myeloid cells. *Proc. Natl. Acad. Sci. USA* 82:2379-2383.
- Flores-Riveros, J. R., E. Sibley, T. Kastelic, and M. D. Lane. 1989. Substrate phosphorylation catalyzed by the insulin receptor tyrosine kinase: kinetic correlation to autophosphorylation of specific sites in the beta subunit. *J. Biol. Chem.* 264:21557-21572.
- Frohman, M. A., M. K. Dush, and G. R. Martin. 1988. Rapid production of full-length cDNAs from rare transcripts: amplification using a single gene-specific oligonucleotide primer. *Proc. Natl. Acad. Sci. USA* 85:8993-9002.
- Grant, S. G. N., T. J. O'Dell, K. A. Karl, P. L. Stein, P. Soriano, and E. R. Kandel. 1992. Impaired long-term potentiation, spatial learning, and hippocampal development in *fyn* mutant mice. *Science* 258:1903-1910.
- Guan, J.-L., and D. Shalloway. 1992. Regulation of focal adhesion-associated protein tyrosine kinase by both cellular adhesion and oncogenic transformation. *Nature (London)* 358:690-692.
- Hanks, S. K., M. B. Calalb, M. C. Harper, and S. K. Patel. 1992. Focal adhesion protein-tyrosine kinase phosphorylated in response to cell attachment to fibronectin. *Proc. Natl. Acad. Sci. USA* 89:8487-8491.
- Hanks, S. K., A. M. Quinn, and T. Hunter. 1988. The protein kinase family: conserved features and deduced phylogeny of the catalytic domains. *Science* 241:42-52.
- Harpur, A. G., A.-C. Andres, A. Ziemiecki, R. R. Aston, and A. F. Wilks. 1992. JAK2, a third member of the JAK family of protein tyrosine kinases. *Oncogene* 7:1347-1353.

20. Hatakeyama, M., T. Kano, N. Kobayashi, A. Kawahara, S. D. Levin, R. M. Perlmutter, and T. Taniguchi. 1991. Interaction of the IL-2 receptor with the src-family kinase p56<sup>lck</sup>: identification of novel intermolecular association. *Science* **252**:1523–1528.
21. Hayashi, T., H. Ohtsuka, K. Kuwabara, Y. Mafune, N. Miyashita, K. Moriawaki, Y. Takahashi, and R. Kominami. 1993. A variant family of mouse minor satellite located on the centromeric region of chromosome 2. *Genetics* **17**:490–492.
22. Henikoff, S. 1984. Unidirectional digestion with exonuclease III creates targeted breakpoints for DNA sequencing. *Gene* **28**:351–359.
23. Heyeck, S. D., and L. Berg. 1993. Developmental regulation of a murine T-cell-specific tyrosine kinase gene, *Tsk*. *Proc. Natl. Acad. Sci. USA* **90**:669–673.
24. Holtzman, D. A., W. D. Cook, and A. R. Dunn. 1987. Isolation and sequence of cDNA corresponding to a src-related gene expressed in murine hemopoietic cells. *Proc. Natl. Acad. Sci. USA* **84**:8325–8329.
25. Horita, K., T. Yagi, N. Kohmura, Y. Tomooka, Y. Ikawa, and S. Aizawa. 1992. A novel tyrosine kinase, *hyk*, expressed in murine embryonic stem cells. *Biochem. Biophys. Res. Commun.* **189**:1747–1753.
26. Hovens, C., S. A. Stacker, A.-C. Andres, A. G. Harpur, A. Ziemiecki, and A. F. Wilks. 1992. RYK, a receptor tyrosine kinase-related molecule with unusual kinase domain motifs. *Proc. Natl. Acad. Sci. USA* **89**:11818–11822.
27. Hunter, T. 1991. Protein kinase classification. *Methods Enzymol.* **200**:3–33.
28. Hutchcroft, J. E., M. L. Harrison, and R. L. Geahlen. 1992. Association of the 72-kDa protein-tyrosine kinase PTK72 with the B cell antigen receptor. *J. Biol. Chem.* **267**:8613–8619.
29. Imamoto, A., and P. Soriano. 1993. Disruption of the *csk* gene encoding a negative regulator of Src family tyrosine kinases, leads to neural tube defects and embryonic lethality in mice. *Cell* **73**:1117–1124.
30. Kelman, Z., D. Simon-Chazottes, J.-L. Guent, and Y. Yarden. 1993. The murine *vik* gene (chromosome 9) encodes a putative receptor with unique protein kinase motifs. *Oncogene* **8**:37–44.
31. Kitani, H., R. Shibata, T. Sakakura, and Y. Tomooka. 1991. Isolation and characterization of mouse neural precursor cells in primary culture. *In Vitro Cell. Dev. Biol.* **27A**:615–624.
32. Koch, C. A., D. Anderson, M. F. Moran, C. Ellis, and T. Pawson. 1991. SH2 and SH3 domains: elements that control interactions of cytoplasmic signaling proteins. *Science* **252**:668–674.
33. Kozak, M. 1984. Compilation and analysis of sequences upstream from the transcriptional start site in eukaryote mRNAs. *Nucleic Acids Res.* **12**:857–872.
34. Lai, C., and G. Lemke. 1991. An extended family of protein-tyrosine kinase genes differentially expressed in vertebrate nervous system. *Neuron* **6**:691–704.
35. Lee, J., Z. Wang, S. Luoh, W. I. Wood, and D. T. Scadden. 1994. Cloning of frk, a novel intracellular src-like tyrosine kinase-encoding gene. *Gene* **138**:247–251.
36. Lowell, C., P. Soriano, and H. Varmus. 1994. Functional overlap in the src gene family: inactivation of hck and fgr impairs natural immunity. *Genes Dev.* **8**:387–398.
37. Mano, H., K. Mano, B. Tang, M. Koehler, T. Yi, D. J. Gilgert, N. A. Jenkins, N. G. Copeland, and J. N. Ihle. 1993. Expression of a novel form of *Tec* kinase in hematopoietic cells and mapping of the gene to chromosome 5 near *Kit*. *Oncogene* **8**:417–424.
38. Mansukhani, A., D. Moscatelli, D. Talarico, V. Levytska, and C. Basiglio. 1990. A murine fibroblast growth factor (FGF) receptor expressed in CHO cells is activated by basic FGF and Kaposi FGF. *Proc. Natl. Acad. Sci. USA* **87**:4378–4382.
39. Marth, D. J., R. Peet, E. G. Krebs, and R. M. Perlmutter. 1985. A lymphocyte-specific protein-tyrosine kinase gene is rearranged and overexpressed in the murine T cell lymphoma LSTRA. *Cell* **43**:393–404.
40. Martinez, R., B. M. Mathey-Prevot, A. Bernards, and D. Baltimore. 1987. Neural pp60<sup>c-src</sup> contains a six-amino acid insertion relative to its non-neural counterpart. *Science* **237**:411–415.
41. Matsumoto, K., M. Arai, N. Ishihara, A. Ando, H. Inoko, and T. Ikemura. 1992. Cluster of fibronectin type III repeats found in the human major histocompatibility complex class III region shows the highest homology with the repeats in an extracellular matrix protein, tenascin. *Genomics* **12**:485–491.
42. McKnight, G. S. 1978. The induction of ovalbumin and coalbumin mRNA by estrogen and progesterone in chick oviduct explant cultures. *Cell* **14**:403–413.
43. Molina, T. J., M. E. Backmann, T. M. Kundig, R. M. Zinkernagel, and T. W. Mak. 1993. Peripheral T cell in mice lacking p56<sup>lck</sup> do not express significant antiviral effector functions. *J. Immunol.* **151**:699–706.
44. Nada, S., M. Okada, A. MacAuley, J. Cooper, and H. Nakagawa. 1991. Cloning of a complementary DNA for a protein-tyrosine kinase that specifically phosphorylates a negative regulatory site of p60<sup>c-src</sup>. *Nature (London)* **351**:69–72.
45. Nada, S., T. Yagi, H. Takeda, T. Tokunaga, H. Nakagawa, Y. Ikawa, M. Okada, and S. Aizawa. 1993. Constitutive activation of Src family kinases in mouse embryos that lack Csk. *Cell* **73**:1125–1135.
46. Norenberg, U., H. Wille, J. M. Wolff, R. Frank, and G. Rathjen. 1991. The chicken neural extracellular matrix molecule restrictin: similarity with EGF-, fibronectin type III-, and fibrinogen-like motifs. *Neuron* **8**:849–863.
47. Okada, M. S. Nada, Y. Yamanashi, T. Yamamoto, and H. Nakagawa. 1991. Csk: a protein-tyrosine kinase involved in regulation of src family kinases. *J. Biol. Chem.* **266**:24249–24252.
48. Partanen, J., T. P. Makela, E. Eerola, J. Korhonen, H. Hirvonen, L. Claesson-Welsh, and K. Alitalo. 1991. FGFR-4, a novel acidic fibroblast growth factor receptor with a distinct expression pattern. *EMBO J.* **10**:1347–1354.
49. Pawson, T., and G. D. Gish. 1992. SH2 and SH3 domains: from structure to function. *Cell* **71**:359–362.
50. Quintrell, N., R. Lebo, H. Varmus, J. M. Bishop, M. J. Pettenati, M. M. Le Beau, M. O. Diaz, and J. D. Rowley. 1987. Identification of a human gene (*HCK*) that encodes a protein-tyrosine kinase and is expressed in hemopoietic cells. *Mol. Cell. Biol.* **7**:2267–2275.
51. Rawlings, D. J., D. C. Saffran, S. Tsukada, D. A. Largaespada, J. C. Grimaldi, L. Cohen, R. N. Mohr, J. F. Bazan, M. Howard, N. G. Copeland, N. A. Jenkins, and O. N. Witte. 1993. Mutation of unique region of Bruton's tyrosine kinase in immunodeficient XID mice. *Science* **261**:358–361.
52. Resnekov, O., and Y. Aloni. 1989. RNA polymerase II is capable of pausing and prematurely terminating transcription at a precise location in vivo and in vitro. *Proc. Natl. Acad. Sci. USA* **86**:12–16.
53. Rose-John, S., A. Dietrich, and F. Marks. 1988. Molecular cloning of mouse protein kinase C (PKC) cDNA from Swiss 3T3 fibroblasts. *Gene* **74**:465–471.
54. Rudnicki, M. A., T. Braun, S. Himura, and R. Jaenisch. 1992. Inactivation of *myoD* in mice leads to up-regulation of the myogenic HLH gene *myf-5* and results in apparently normal muscle development. *Cell* **71**:383–390.
55. Rudnicki, M. A., P. N. J. Schnegelsberg, R. H. Stead, T. Braun, H.-H. Arnold, and R. Jaenisch. 1993. MyoD or Myf-5 is required for the formation of skeletal muscle. *Cell* **75**:1351–1359.
56. Saga, Y., T. Yagi, Y. Ikawa, T. Sakakura, and S. Aizawa. 1992. Mice develop normally without tenascin. *Genes Dev.* **6**:1821–1831.
57. Saitou, N., and M. Nei. 1987. The neighbor-joining method: a new method for reconstructing phylogenetic trees. *Mol. Biol. Evol.* **4**:406–425.
58. Sambrook, J., E. F. Fritsch, and T. Maniatis. 1989. Molecular cloning: a laboratory manual, 2nd ed. Cold Spring Harbor Laboratory Press, Cold Spring Harbor, N.Y.
59. Samelson, L. E., A. F. Phillips, E. T. Luong, and R. D. Klausner. 1990. Association of the fyn protein-tyrosine kinase with the T-cell antigen receptor. *Proc. Natl. Acad. Sci. USA* **87**:4358–4362.
60. Schaller, M. D., C. A. Borgman, B. S. Cobb, R. R. Vines, A. B. Reynolds, and J. T. Parsons. 1992. pp125<sup>FAK</sup>, a structurally distinctive protein-tyrosine kinase associated with focal adhesions. *Proc. Natl. Acad. Sci. USA* **89**:5192–5196.
61. Shaw, G., and R. Kamen. 1986. A conserved AU sequence from the 3' untranslated region of GM-CSF mRNA mediates selective mRNA degradation. *Cell* **46**:659–667.
62. Siliciano, J. D., T. A. Morrow, and S. V. Desiderio. 1992. *itk*, a T-cell-specific tyrosine kinase gene induced by interleukin 2. *Proc.*

- Natl. Acad. Sci. USA **89**:11194–11198.
63. Soriano, P., C. Montgomery, R. Geske, and A. Bradley. 1991. Targeted disruption of the *c-src* proto-oncogene leads to osteopetrosis in mice. *Cell* **64**:693–702.
  64. Stein, P. L., H.-M. Lee, S. Rich, and P. Soriano. 1992. *pp59<sup>lck</sup>* mutant mice display differential signaling in thymocytes and peripheral T cells. *Cell* **70**:741–750.
  65. Sudol, M., H. Greulich, L. Newman, A. Sarkar, J. Sukegawa, and T. Yamamoto. 1993. A novel Yes-related kinase, Yrk, is expressed at elevated levels in neural and hematopoietic tissues. *Oncogene* **8**:823–831.
  66. Taniguchi, T., T. Kobayashi, J. Kondo, K. Takahashi, H. Nakamura, J. Suzuki, K. Nagai, T. Yamada, S.-I. Nakamura, and H. Yamamura. 1991. Molecular cloning of a porcine gene *syk* that encodes a 72-kDa protein-tyrosine kinase showing high susceptibility to proteolysis. *J. Biol. Chem.* **266**:15790–15796.
  67. Tomooka, Y., H. Kitani, N. Jing, M. Matsushima, and T. Sakakura. 1993. Reconstruction of neural tube-like structures in vitro from primary neural precursor cells. *Proc. Natl. Acad. Sci. USA* **90**:9683–9687.
  68. Tsukada, S., D. C. Saffran, D. J. Rawlings, O. Parolini, R. C. Allen, I. Klisak, R. S. Sparkes, H. Kubagawa, T. Mohandas, S. Quan, J. W. Belmont, M. D. Cooper, M. E. Conley, and O. N. Witte. 1993. Deficient expression of a B cell cytoplasmic tyrosine kinase in human X-linked agammaglobulinemia. *Cell* **72**:279–290.
  69. Tsukada, T., Y. Tomooka, S. Takai, Y. Ueda, S. Nishikawa, T. Yagi, T. Tokunaga, N. Takeda, Y. Suda, S. Abe, I. Matsuo, Y. Ikawa, and S. Aizawa. 1993. Enhanced proliferative potential in culture of cells from *p53*-deficient mice. *Oncogene* **8**:3313–3322.
  70. Uhler, M. D., J. C. Chrivia, and G. S. McKnight. 1986. Evidence for a second isoform of the catalytic subunit of cAMP-dependent protein kinase. *J. Biol. Chem.* **261**:15360–15363.
  71. Velazquez, L., M. Fellous, G. R. Stark, and S. Pellegrini. 1992. A protein tyrosine kinase in the interferon  $\alpha/\beta$  signaling pathway. *Cell* **70**:313–322.
  72. Veillette, A., M. A. Bookman, E. M. Horak, and J. B. Bolen. 1988. The CD4 and CD8 T cell surface antigens are associated with the internal membrane tyrosine-protein kinase *p56<sup>lck</sup>*. *Cell* **55**:301–308.
  73. Vetrie, D., I. Voechovsky, P. Sideras, J. Holland, A. Davies, F. Flinter, L. Hammarström, C. Kinnon, R. Levinsky, M. Bobrow, C. I. E. Smith, and D. R. Bentley. 1993. The gene involved in X-linked agammaglobulinemia is a member of the *src* family of protein-tyrosine kinases. *Nature (London)* **361**:226–233.
  74. Wilks, A. F. 1989. Two putative protein-tyrosine kinases identified by application of the polymerase chain reaction. *Proc. Natl. Acad. Sci. USA* **86**:1603–1607.
  75. Wilks, A. F., A. G. Harpur, R. R. Kurban, S. J. Ralph, G. Zurcher, and A. Ziemiecki. 1991. Two novel protein-tyrosine kinases, each with a second phosphotransferase-related catalytic domain, define a new class of protein kinase. *Mol. Cell. Biol.* **11**:2057–2065.
  76. Wilks, A. F., R. R. Kurban, C. M. Hovens, and S. J. Ralph. 1989. The application of the polymerase chain reaction to cloning members of the protein tyrosine kinase family. *Gene* **85**:67–74.
  77. Yagi, T., S. Nada, N. Watanabe, H. Tamemoto, N. Kohmura, Y. Ikawa, and S. Aizawa. 1993. A novel negative selection for homologous recombinants using diphtheria toxin A fragment gene. *Anal. Biochem.* **214**:77–86.
  78. Yagi, T., Y. Shigetani, Y. Furuta, S. Nada, N. Okado, Y. Ikawa, and S. Aizawa. *Fyn* expression during neurogenesis in mouse embryos. *Oncogene*, in press.
  79. Yagi, T., Y. Shigetani, N. Takeda, N. Okado, Y. Ikawa, and S. Aizawa. 1993. Regional localization of *Fyn* in adult brain; studies with mice in which *fyn* gene was replaced by *lacZ*. *Oncogene* **8**:3343–3351.
  80. Yagi, T., T. Tokunaga, Y. Fruta, S. Nada, M. Yoshida, T. Tsukada, Y. Saga, N. Takeda, Y. Ikawa, and S. Aizawa. 1993. A novel ES cell line, TT2, with high germline-differentiating potency. *Anal. Biochem.* **214**:70–76.
  81. Yamada, N., Y. Kawakami, H. Kimura, H. Fukamachi, G. Baier, A. Altman, T. Kato, Y. Inagaki, and T. Kawakami. Structure and expression of novel protein-tyrosine kinases, *emb* and *emt*, in hematopoietic cells. 1993. *Biochem. Biophys. Res. Commun.* **192**:231–240.
  82. Yamanashi, Y., T. Kakiuchi, J. Mizuguchi, T. Yamamoto, and K. Toyoshima. 1991. Association of B cell antigen receptor with protein tyrosine kinase *Lyn*. *Science* **251**:192–194.
  83. Ziegler, S. F., T. A. Bird, J. A. Schneringer, K. A. Schooley, and P. R. Baum. 1993. Molecular cloning and characterization of a novel receptor protein tyrosine kinase from human placenta. *Oncogene* **8**:663–670.
  84. Ziegler, S. F., J. D. Marth, D. B. Lewis, and R. M. Perlmutter. 1987. Novel protein-tyrosine kinase gene (*hck*) preferentially expressed in cells of hematopoietic origin. *Mol. Cell. Biol.* **7**:2276–2285.