

Inhibition of T-Cell Antigen Receptor-Mediated Transmembrane Signaling by Protein Kinase C Activation

ROBERT T. ABRAHAM,* STEFFAN N. HO, THOMAS J. BARNA, KARNA M. RUSOVICK,
AND DAVID J. MCKEAN

Department of Immunology, Mayo Clinic, Rochester, Minnesota 55905

Received 6 April 1988/Accepted 15 September 1988

The murine T-lymphoma cell line LBRM-33 is known to require synergistic signals delivered through the antigen receptor (T_i-CD3) complex, together with interleukin 1 (IL-1), for activation of IL-2 gene expression and IL-2 production. Although 12-O-tetradecanoylphorbol-13-acetate (TPA) was capable of replacing IL-1 as an activating stimulus under certain conditions, biologic studies indicated that TPA failed to synergize with T_i-CD3-dependent stimuli under conditions in which IL-1 was clearly active. Acute exposure to TPA and other active phorbol esters resulted in a concentration-dependent inhibition of the increases in phosphoinositide hydrolysis and intracellular free Ca²⁺ concentration stimulated by phytohemagglutinin or anti-T_i antibodies. TPA treatment induced no direct alteration of phospholipase C enzymatic activities in LBRM-33 cells. In contrast, both T_i-CD3 cross-linkage and TPA rapidly stimulated the phosphorylation of identical CD3 complex polypeptides, presumably via activation of protein kinase C. Exposure of LBRM-33 cells to TPA resulted in a time-dependent, partial down-regulation of surface T_i-CD3 expression. Thus, TPA treatment inhibited the responsiveness of LBRM-33 cells to T_i-CD3-dependent stimuli by inducing an early desensitization of T_i-CD3 receptors, followed by a decrease in membrane receptor expression. These studies indicate that phorbol esters deliver bidirectional signals that both inhibit T_i-CD3-dependent phosphoinositide hydrolysis and augment IL-2 production in LBRM-33 cells.

The T-cell antigen receptor is a multimeric structure consisting of a clonotypic, disulfide-linked heterodimer (T_i) noncovalently associated with a series of invariant transmembrane proteins collectively termed CD3 (40, 41). Physiologic triggering of quiescent T cells occurs upon T_i-CD3 binding of antigen plus major histocompatibility complex molecules on the surface of accessory cells (4). Cross-linkage of surface T_i-CD3 receptors by specific ligands (antigens, mitogens, anti-T_i-CD3 antibodies) initiates a sequence of transmembrane and intracellular events that transmit signals requisite for the activation of resting T cells (46). Both the structural features and the close association of the CD3 polypeptides with the ligand-binding T_i heterodimer suggest that the CD3 complex is involved in signal transduction during T_i cross-linking.

The mechanism by which T_i-CD3 stimulation initiates transmission of regulatory signals across the T-cell plasma membrane remains undefined. However, certain biochemical consequences of T_i-CD3 cross-linking have been elucidated. Antigen receptor cross-linking induces rapid increases in the hydrolysis of membrane inositol phospholipids, particularly phosphatidylinositol-4,5-bisphosphate (PIP₂) (46). This hydrolytic reaction is catalyzed by a hormone-sensitive phospholipase C activity and gives rise to two molecules, inositol-1,4,5-trisphosphate and 1,2-diacylglycerol, known to stimulate mobilization of intracellular calcium ([Ca²⁺]_i) and activation of protein kinase C (pkC), respectively (see references 1 and 7 for reviews). The proposal that these biochemical events are involved in stimulus response coupling during T-cell activation is supported by the abilities of pharmacologic agents that directly elevate [Ca²⁺]_i and pkC activity (e.g., Ca²⁺ ionophores and phorbol esters, respec-

tively) to bypass the ligand-receptor interactions normally required to stimulate resting T lymphocytes (5, 22).

Although phorbol ester treatment stimulates a diversity of cellular responses, these compounds also possess negative regulatory effects on certain cellular functions, including those of specific membrane receptors. Acute treatment with 12-O-tetradecanoylphorbol-13-acetate (TPA) strongly suppressed Ca²⁺ mobilization induced by fMet-Leu-Phe in the human leukemic cell line HL60 (25), by carbachol in astrocytoma cells (36), and by anti-immunoglobulin antibodies in B cells (32). The results of these studies suggested that receptor desensitization was secondary to the pkC-mediated phosphorylation of a protein(s) critical to receptor-phospholipase C coupling. Receptor phosphorylation represents one major mechanism by which pkC activation could modulate receptor affinity, surface expression, or coupling to signal transduction systems (28). Alternatively, in certain receptor systems, pkC-mediated protein phosphorylation appears to inhibit directly the function of a guanine nucleotide-binding (G) protein responsible for integrating receptor stimulation and phospholipase C activation (20, 36).

We previously reported that short-term exposure to TPA partially suppressed the [Ca²⁺]_i increase induced by phytohemagglutinin (PHA) in LBRM-33 cells (12). In this study, we have further characterized the effect of TPA on transmembrane signaling in these cells. The results indicate that TPA-dependent pkC activation in T cells has bidirectional effects on the cellular activation process. Increases in pkC activity not only deliver a synergistic auxiliary signal for T-cell activation but also negatively modulate T_i-CD3-dependent transmembrane signaling by uncoupling the receptor complex from phospholipase C. Thus, pkC activation may represent an important autoregulatory mechanism that limits the output of activating signals from the T_i-CD3 receptor in T cells.

* Corresponding author.

MATERIALS AND METHODS

Cells. The LBRM-33 (subclone 1A5) cell line, derived from a radiation-induced splenic T-cell lymphoma in the B10.BR mouse strain (15), was obtained from the American Type Culture Collection (Rockville, Md.). LBRM-33 cells were passaged in spinner flasks in complete medium containing RPMI 1640, 10% heat-inactivated fetal calf serum, 2 mM L-glutamine, 100 U of penicillin per ml, 100 µg of streptomycin per ml, and 50 µM 2-mercaptoethanol, buffered to pH 7.3 with 10 mM *N*-2-hydroxyethylpiperazine-*N'*-2-ethanesulfonic acid (HEPES) (3).

Reagents. All chemicals and drugs, unless otherwise noted, were obtained from Sigma Chemical Co. (St. Louis, Mo.). [³H]phosphatidylinositol ([³H]PI; specific activity, 10 Ci/mmol), [³H]PIP₂ (5 Ci/mmol), and *myo*-[2-³H]inositol (14 Ci/mmol), and carrier-free ³²P_i were from Dupont, NEN Research Products (Boston, Mass.). Protein was assayed by the method of Bradford (9) with protein standards (bovine immunoglobulin) and reagents obtained from Bio-Rad Laboratories (Richmond, Calif.). Ionomycin and fura-2 acetoxy-methyl ester were purchased from Calbiochem-Behring (La Jolla, Calif.). Ionomycin stock solutions in dimethyl sulfoxide and phorbol ester stock solutions in absolute ethanol were prepared as previously described (2). Recombinant murine interleukin 1α (IL-1) was the gift of Steven Mizel (Bowman-Gray School of Medicine, Winston-Salem, N.C.).

Antibodies. KJ16-133 (19) and F23.1 (44), monoclonal antibodies directed against Vβ8-encoded determinants expressed by the T_H heterodimer of LBRM-33 cells, were generously provided by Phillipa Marrack (National Jewish Hospital, Denver, Colo.) and Larry Samelson (Cell Biology and Metabolism Branch, National Institutes of Health, Bethesda, Md.), respectively. The mouse anti-rat kappa antibody MAR18.5 (39) was obtained from the American Type Culture Collection. The monoclonal antibody 145-2C11 (29), directed against the ε subunit of the murine CD3 complex, was the gift of Jeffrey Bluestone, University of Chicago (Chicago, Ill.). Antibodies were prepared as concentrated serum-free culture supernatants generated by ultrafiltration through a 10,000-molecular-weight cutoff membrane (YM-10; Amicon Corp., Lexington, Mass.) and dialysis against phosphate-buffered saline.

Bioassays. LBRM-33 cells were stimulated for 4 or 24 h before collection of the conditioned medium for assay of IL-2 biologic activity, using the IL-2-dependent T-cell line HT-2 (45). Four-hour bioassays were performed in 48-well tissue culture plates containing 2 × 10⁶ LBRM-33 cells per well in a final volume of 0.5 ml of complete medium. Twenty-four-hour bioassays were performed in 96-well plates containing 10⁵ LBRM-33 cells per well in a final volume of 0.2 ml of complete medium. The assay for IL-2 biologic activity in LBRM-33 cell-conditioned supernatants has been described in detail elsewhere (3). Although HT-2 cells also respond to IL-4, Northern (RNA) blot analyses of mRNA from stimulated LBRM-33 cells revealed only IL-2 mRNA transcripts (S. N. Ho, unpublished data), which indicates that IL-2 represents the only growth-promoting activity measured in these experiments. Preliminary experiments revealed that the IL-2 response of HT-2 cells was not influenced by the mediators added to the primary cultures at the indicated concentrations and supernatant dilutions.

Flow cytofluorometric analysis. Cell surface expression of the CD3 complex on LBRM-33 cells was quantitated by indirect immunofluorescence on a FACS IV cytofluorometer (Becton Dickinson and Co., Palo Alto, Calif.). LBRM-33

cells (3 × 10⁶ cells per sample) were incubated in duplicate at 37°C with TPA for predetermined times and then rapidly diluted in 10 volumes of ice-cold Hanks balanced salt solution (HBSS). The cells were centrifuged and fixed with HBSS containing 1% paraformaldehyde. CD3 expression was quantitated by staining the cells with the 145-2C11 monoclonal antibody followed by fluorescein isothiocyanate-conjugated rabbit anti-hamster immunoglobulin (Organon Teknica, Malvern, Pa.).

Release of inositol phosphates. Labeling of LBRM-33 cells with *myo*-[2-³H]inositol and measurement of the release of inositol-1-monophosphate (IP₁), inositol-1,4-bisphosphate (IP₂), and inositol trisphosphates (IP₃) were performed by a modification (2) of the method of Bijsterbosch et al. (8). Samples (1.5 × 10⁶ cells) were prepared in triplicate, and assays were performed at 37°C. Except where indicated otherwise, total inositol phosphate release was determined by elution of the anion-exchange column with 5 ml of 1.2 M ammonium formate–0.1 M formic acid.

Measurement of [Ca²⁺]_i. Changes in [Ca²⁺]_i during stimulation of LBRM-33 cells were studied by using cells preloaded with the Ca²⁺-sensitive fluorescent dye fura-2 (17). The Ca²⁺-specific fluorescence of stirred, dye-loaded cell suspensions was measured as described elsewhere (2).

Phospholipase C activities. Phospholipase C activities present in cytosolic extracts from LBRM-33 cells were assayed against both PI and PIP₂ bilayer vesicles by a modification of previously described methods (24, 27). LBRM-33 cells were incubated at 10⁷ cells per ml (5 × 10⁷ cells per sample) in HBSS containing 0.2% bovine serum albumin in the presence or absence of various stimuli. After incubation, the cells were rapidly diluted with 5 volumes of ice-cold HBSS–0.2% bovine serum albumin and centrifuged. All remaining steps were performed at 0 to 4°C. The cells were washed one time with HBSS–0.2% bovine serum albumin, suspended in phosphate-buffered saline (pH 7.2) containing 0.5 mM EDTA, and pelleted once again. The cells were lysed with a glass Dounce tissue grinder in 1.5 ml of hypotonic buffer containing 10 mM HEPES (pH 7.0), 5 mM ethylene glycol-bis(β-aminoethyl ether)-*N,N,N',N'*-tetraacetic acid (EGTA), 1 mM MgCl₂, 0.2 mM dithiothreitol, and 0.5 mM phenylmethylsulfonyl fluoride. The resulting homogenate was centrifuged (600 × *g*, 10 min) to remove nuclei and cellular debris, and the supernatant was recentrifuged at 100,000 × *g* for 40 min. In preliminary experiments, all detectable cellular phospholipase C activities were found in the post-100,000 × *g* cytosolic fraction of LBRM-33 cells (data not shown). The cytosolic fractions were diluted to 200 µg of protein per ml in 50 mM 2-(*N*-morpholino)ethanesulfonic acid (MES)–2 mM EGTA, pH 6.0. Phospholipase C activities present in the cytosolic extracts were assayed in triplicate under linear reaction conditions. When PI was the substrate, the sample tubes contained, in a final volume of 250 µl, 50 mM MES, 2 mM EGTA, 1.0 mM CaCl₂, 0.05% (wt/vol) sodium cholate, and 10 µM [³H]PI (specific activity, 4 µCi/µmol). Reactions were initiated by addition of 50 µl of diluted cytosolic extract, and the samples were incubated at 37°C for 3 min. Phospholipase C-mediated hydrolysis of [³H]PIP₂ was determined by the same procedure except that 0.025% (wt/vol) octylglucoside was substituted for sodium cholate and the CaCl₂ concentration was lowered to 0.2 mM. All reactions were terminated by addition of 1 ml of chloroform-methanol-HCl (100:100:0.6). Background controls received the organic solvent mixture before addition of cytosol. The samples were vortexed, and 0.3 ml of either 1 N HCl–5 mM EGTA (for [³H]PI hydrolysis) or 2 M KCl (for

[³H]PIP₂ hydrolysis) was added to each tube. After mixing and centrifugation, the upper aqueous phase was assayed for ³H-labeled inositol phosphates by liquid scintillation counting.

³²P_i labeling, immunoprecipitation, and two-dimensional electrophoresis. LBRM-33 cells were washed in labeling medium (phosphate-free minimal essential medium containing 5% fetal calf serum, 2 mM L-glutamine, and 50 μM 2-mercaptoethanol, buffered to pH 7.3 with 10 mM HEPES). The washed cell pellet was suspended in labeling medium at 2.5 × 10⁷ cells per ml and incubated for 30 min at 37°C. The phosphate-depleted cells were then centrifuged and suspended at the same density in labeling medium containing 0.5 mCi of ³²P_i per ml. After a 90-min incubation at 37°C, 2-ml portions (5 × 10⁷ cells) were transferred to 50-ml polypropylene tubes containing 8 ml of labeling medium plus various stimuli. The samples were incubated at 37°C for 10 min and then rapidly diluted in 4 volumes of ice-cold phosphate-buffered saline containing 10 mM sodium pyrophosphate, 50 mM sodium fluoride, and 10 μM sodium orthovanadate. After centrifugation, the cells were suspended in 2 ml of lysis buffer (25 mM Tris hydrochloride [pH 8.0], 100 mM NaCl, 1 mM EDTA, 50 mM NaF, 5 mM iodoacetic acid, 10 μM sodium orthovanadate, 10 μg of leupeptin per ml, 1 mM phenylmethylsulfonyl fluoride) containing 0.5% (wt/vol) Triton X-100. The samples were incubated at 0°C for 30 min with occasional gentle mixing and then centrifuged at 1,000 × g for 5 min to remove insoluble material. Postnuclear supernatants were precleared for 30 min with protein A-Sepharose beads and then immunoprecipitated with a mixture of monoclonal antibodies F23.1 and 145-2C11 adsorbed to protein A-Sepharose. After 2 h at 4°C, the protein A-Sepharose beads were washed four times with lysis buffer containing 0.1% Triton X-100. The immunoprecipitates were eluted with 60 μl of sample buffer (9.5 M urea, 2% Triton X-100, 5% [wt/vol] 2-mercaptoethanol, 2% ampholines [pH 3 to 10]). Two-dimensional nonequilibrium pH gradient electrophoresis (NEPHGE)-sodium dodecyl sulfate-polyacrylamide gel electrophoresis of the eluted proteins was performed as described by Samelson et al. (40), with the second-dimension sodium dodecyl sulfate-polyacrylamide gel electrophoresis performed in a 12.5% acrylamide slab gel. Prestained molecular weight standards were run in parallel with each set of slab gels. ³²P-labeled proteins were detected by autoradiography at -70°C for 4 days.

RESULTS

Bidirectional effects of TPA on stimulus-induced IL-2 production. LBRM-33 cells are activated to secrete high levels of IL-2 by synergistic signals delivered by PHA and IL-1 (15) or, alternatively, by replacement of these mediators with a Ca²⁺ ionophore and the phorbol ester TPA (47). However, in a previous study (2) we observed that TPA provided a less effective second signal for IL-2 production than did IL-1 when PHA was present as the primary stimulus. The data presented in Fig. 1 describe this phenomenon in greater detail. Figure 1A provides representative results from 4-h culture experiments in which LBRM-33 cells were stimulated with 0.3% (vol/vol) PHA in the absence or presence of IL-1 and/or TPA. The IL-1 and TPA concentrations (10 U/ml and 30 nM, respectively) used in these studies each provided a maximal costimulatory signal in the assay (data not shown). Under these conditions, PHA alone stimulated no detectable IL-2 production, and TPA was completely inactive as a costimulus with PHA. In contrast, the combination

of PHA plus IL-1 stimulated significant IL-2 release. These 4-h bioassays, therefore, demonstrate the marked difference between IL-1 and TPA in the provision of second signals for IL-2 production. Moreover, the combination of PHA, IL-1, and TPA stimulated higher levels of IL-2 production than were attainable with PHA plus IL-1. It is important to note that IL-1 plus TPA alone stimulated no IL-2 production at either 4 h (not shown) or 24 h (Fig. 1B). The data presented in Fig. 1B provide representative results from a series of 24-h incubations with the same stimuli. With these longer incubation times, synergy between PHA and TPA was readily apparent, although IL-1 remained the more potent costimulus for IL-2 production. In three independent experiments, the IL-2 level in supernatants from PHA-plus-TPA-stimulated cells ranged from 40 to 65% of the level in supernatants from PHA-plus-IL-1-stimulated cultures (based on comparisons of supernatant dilutions required to produce a half-maximal proliferative response in the IL-2 bioassay). Simultaneous addition of PHA, IL-1, and TPA into LBRM-33 cell cultures consistently resulted in a partial suppression of IL-2 production relative to that observed with PHA plus IL-1 only.

Although T-cell activation initiated by PHA presumably results from cross-linkage of the T_i-CD3 complex (12), other T-cell surface structures react with PHA and may contribute to the activation response (12). To examine the specific effects of TPA on T_i-CD3-dependent signaling, we used a monoclonal anti-T-cell receptor antibody, KJ16.133 (KJ16), shown previously to bind and stimulate the T_i-CD3 complex expressed by LBRM-33 cells (48). In preliminary experiments, the activating properties of the KJ16 antibody were shown to be markedly enhanced by prior complexing with the monoclonal mouse anti-rat kappa-chain antibody MAR18.5. This augmentation of biologic activity appears to result from enhancement of the efficiency or extent (or both) of T_i-CD3 cross-linking (26). MAR18.5 antibody alone had no effect on any parameter of activation examined in this study (data not shown). All experiments were performed with KJ16-MAR18.5 immune complexes under conditions (i.e., antibody ratios and concentration) that yielded optimal biologic responses from LBRM-33 cells in preliminary experiments. Figure 1C provides representative results from 24-h incubations with KJ16-MAR18.5 complexes. The results are comparable to those obtained with PHA after 4 h of cellular stimulation: KJ16-MAR18.5 complexes synergized with IL-1, but not TPA, to stimulate high-level IL-2 release from LBRM-33 cells. Nonetheless, TPA was clearly capable of delivering a positive signal for IL-2 production, because in the presence of both KJ16-MAR18.5 complexes and IL-1, TPA markedly enhanced IL-2 production. Taken together, the studies summarized in Fig. 1 suggested that TPA might deliver both stimulatory and antagonistic signals for IL-2 production in the presence of different T_i-CD3 ligands.

Effects of TPA on [Ca²⁺]_i. Ligand-induced T_i-CD3 cross-linking has been shown to induce rapid increases in [Ca²⁺]_i, due in part to mobilization from labile intracellular stores (46). This increase in [Ca²⁺]_i appears to transduce signals for T-cell activation and lymphokine gene expression (30). We previously demonstrated that acute TPA treatment markedly suppressed the increase in [Ca²⁺]_i normally induced by PHA in LBRM-33 cells (2). In this study, we further characterized the effects of acute TPA exposure on [Ca²⁺]_i changes elicited by a specific T_i-CD3 ligand, the KJ16 antibody. KJ16-MAR18.5 immune complexes rapidly increased [Ca²⁺]_i in fura-2-loaded LBRM-33 cells, as monitored by the increase in the Ca²⁺-specific fluorescence emission from

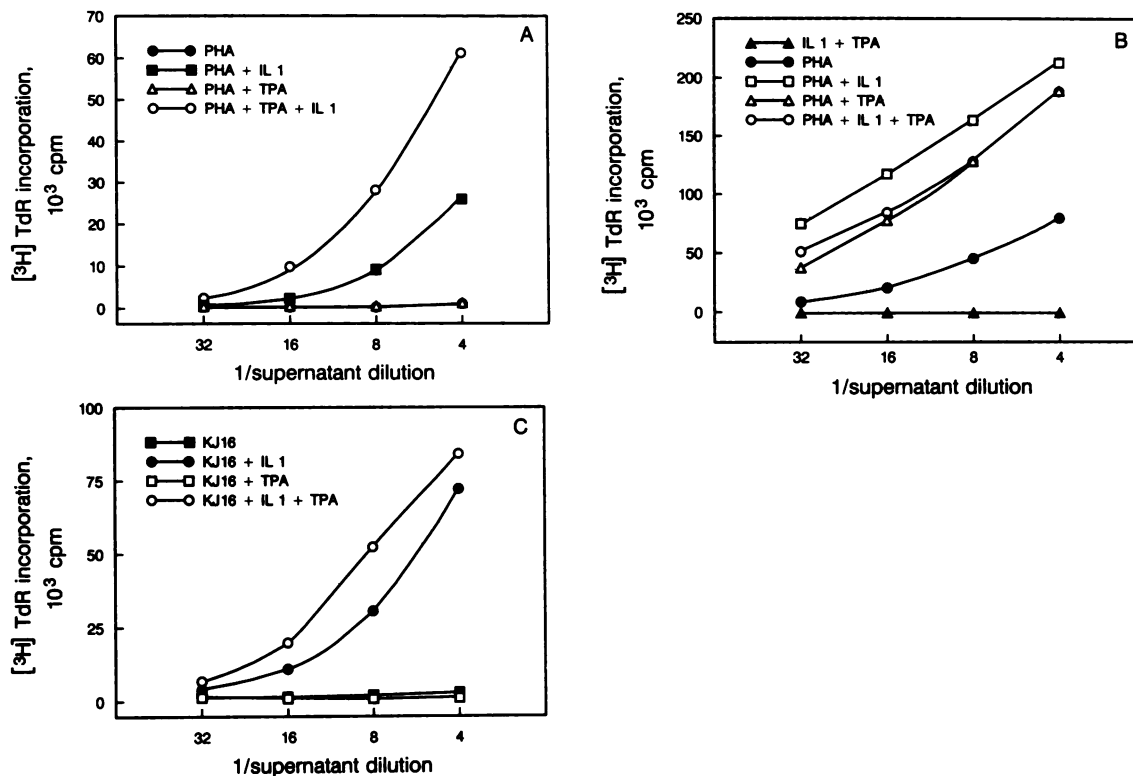

FIG. 1. Effect of TPA on PHA-stimulated or anti- T_i -CD3 antibody-stimulated IL-2 production. LBRM-33 cells were stimulated for (A) 4 h or (B) 24 h with 0.3% PHA or for (C) 24 h with KJ16-MAR18.5 immune complexes in the presence or absence of 10 U of recombinant IL-1 per ml and/or 30 nM TPA. LBRM-33 cell-conditioned supernatants were diluted, and IL-2 bioactivity was determined in secondary cultures of IL-2-dependent HT-2 cells. Data points represent mean values from quadruplicate measurements. Standard deviations were less than 7% of the mean value. The data shown are representative of at least three independent experiments. TdR, Thymidine.

stirred cell suspensions (Fig. 2B). This $[Ca^{2+}]_i$ increase was comparable in magnitude to the plateau phase of the Ca^{2+} signal stimulated by 0.3% PHA (Fig. 2A). Within minutes of addition to the dye-loaded cell suspensions, 16 nM TPA rendered the cells totally nonresponsive to the Ca^{2+} -mobilizing effects of KJ16-MAR18.5 (Fig. 2C and Table 1). TPA alone had no detectable effect on basal $[Ca^{2+}]_i$ in LBRM-33 cells (Fig. 2C). These results suggest that the failure of TPA to synergize with KJ16-MAR18.5 complexes as a costimulus for IL-2 production (Fig. 1) may result from a concomitant blockade of T_i -CD3-dependent Ca^{2+} mobilization, a critical early event in this T_i -CD3-dependent signal transduction pathway.

Effects of TPA on T_i -CD3-dependent phosphoinositide hydrolysis. Cross-linkage of T_i -CD3 receptors on T cells triggers the specific hydrolysis of membrane phosphoinositides and the release of IP_3 , a Ca^{2+} -mobilizing second messenger (7, 46). The inhibitory effects of TPA on the $[Ca^{2+}]_i$ increase in LBRM-33 cells stimulated with PHA (2) or KJ16-MAR18.5 complexes (Table 1) might therefore be secondary to an inhibition by TPA of T_i -CD3-dependent PIP_2 hydrolysis.

TPA induced a concentration-dependent inhibition of inositol phosphate formation in LBRM-33 cells stimulated with either 0.3% PHA or KJ16-MAR18.5 complexes (Fig. 3). In these experiments, the cells were exposed to TPA for less than 5 min before stimulation with PHA or KJ16-MAR18.5 complexes. The concentrations of TPA required to inhibit PHA- and KJ16-MAR18.5-dependent inositol phosphate release by 50% (IC_{50}) were 2.8 and 0.7 nM, respectively. These

IC_{50} s approximate the binding constant of TPA for pK in purified enzyme preparations (6). The lower potency of TPA as an inhibitor of PHA relative to that of KJ16-MAR18.5-stimulated phosphoinositide hydrolysis suggests either that PHA represents a more efficient T_i -CD3 receptor agonist or that PHA activates other phospholipase C-linked membrane receptors with lesser sensitivities to the uncoupling effects of TPA.

Effect of TPA homologs on phosphoinositide hydrolysis. Like TPA, 4 β -phorbol didecanoate (PDD) is known to activate pK in LBRM-33 cells (2), albeit with lower potency in intact cells because of its greater hydrophobicity (11). In contrast, the 4 α -PDD isomer was virtually inactive in these earlier pK translocation studies. 4 α -PDD was correspondingly inactive, over a wide concentration range, as an inhibitor of PHA-stimulated inositol phosphate release in LBRM-33 cells (Fig. 4). The pK-activating isomer, 4 β -PDD, was an effective inhibitor of this response, with an approximate IC_{50} of 3.9 nM. Therefore these results support the hypothesis that T_i -CD3 receptor uncoupling by phorbol esters is mediated through activation of pK in LBRM-33 cells.

Kinetics of TPA-mediated inhibition of specific phosphoinositide hydrolysis. The preceding experiments demonstrated that TPA blocks total inositol phosphate accumulation in LBRM-33 cells stimulated by T_i -CD3 receptor cross-linking. However, IP_3 appears to represent the principal Ca^{2+} -mobilizing second-messenger metabolite generated during receptor activation (7). Therefore, TPA must inhibit specifically the hydrolysis of PIP_2 , and the concomitant formation

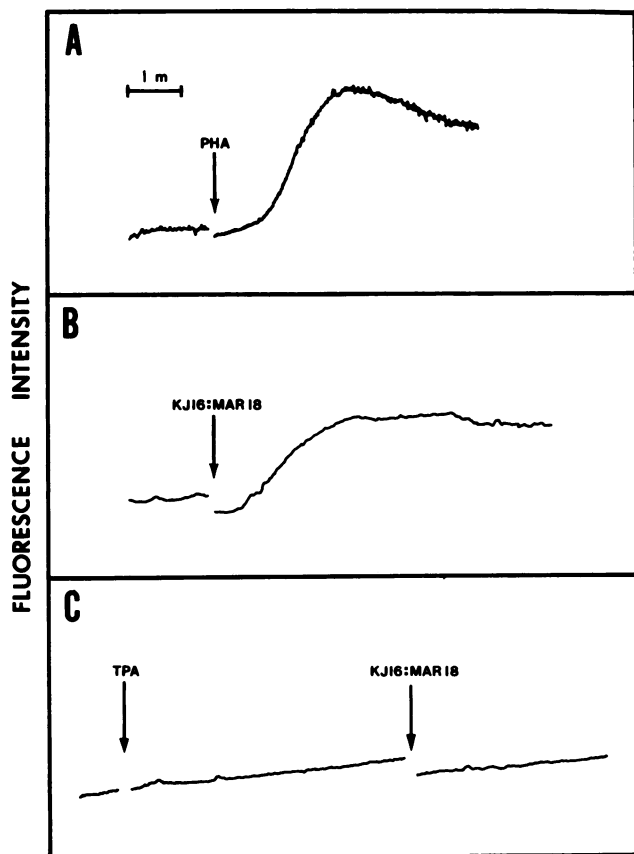

FIG. 2. Effect of TPA on anti-T₁-CD3-stimulated Ca²⁺ mobilization. Fura-2-loaded LBRM-33 cells (2×10^6 cells per ml) were stimulated in stirred cuvettes with (A) 0.3% PHA, (B) KJ16-MAR18.5 immune complexes, or (C) 30 nM TPA followed by KJ16-MAR18.5 immune complexes. Curves depict time-dependent (bar = 1 min) changes in Ca²⁺-dependent fluorescence and are representative of at least four independent determinations.

of IP₃, in PHA- or KJ16-MAR18.5-stimulated cells if receptor uncoupling from phospholipase C is to be implicated in the inhibition of T₁-CD3-dependent Ca²⁺ mobilization. Figure 5 presents a kinetic analysis of the effect of TPA on the release of IP₃ isomers and IP₂ plus IP₁ during cellular stimulation with KJ16-MAR18.5 complexes in the absence of Li⁺ ion. Although LBRM-33 cells stimulated with the T₁-CD3-specific ligand exhibited rapid increases in both inositol phosphate fractions, only IP₃ levels were signifi-

TABLE 1. Effect of TPA on the calcium mobilization induced by KJ16-MAR18.5 complexes in fura-2-loaded LBRM-33 cells

Pretreatment	Stimulus ^a	% Increase in calcium-dependent fluorescence (mean \pm SEM) ^b
Control medium	PHA	35.8 \pm 4.0 (2)
	KJ16-MAR18.5	21.8 \pm 5.2 (4)
TPA (16 nM, 5 min)	KJ16-MAR18.5	2.9 \pm 2.0 (4)

^a Stimuli were either 0.3% (vol/vol) PHA or saturating concentrations of KJ16-MAR18.5 immune complexes.

^b Numbers represent peak percentage increase in Ca²⁺-specific fluorescence over base-line fluorescence values before addition of stimulus. Numbers in parentheses represent number of independent determinations per group.

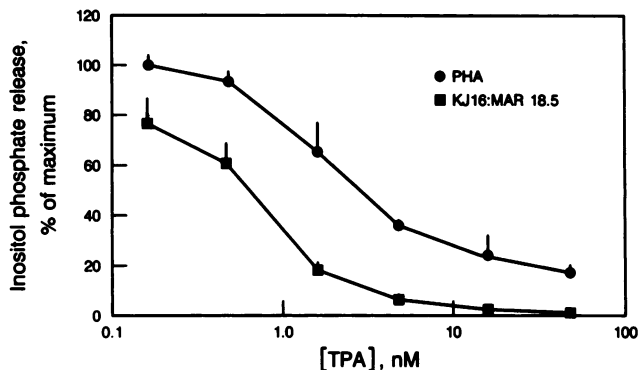

FIG. 3. Effect of TPA on stimulus-induced phosphoinositide hydrolysis. LBRM-33 cells (1.5×10^6 cells per sample) were incubated with 0.3% PHA or KJ16-MAR18.5 immune complexes for 20 min in the presence or absence of the indicated concentrations of TPA. Total release of [³H]inositol phosphate was measured as described in Materials and Methods. Data points represent mean \pm standard error from three separate experiments (three determinations per experiment). Average [³H]inositol phosphate release from stimulated cells in the absence of TPA was $9,154 \pm 1,619$ cpm.

cantly elevated within 1 min of addition of the stimulus (Fig. 5). Both inositol phosphate fractions exhibited maximal elevations after 10 min of stimulation. The addition of 1.6 nM TPA at the start of the incubation induced an immediate and persistent suppression of the stimulus-induced release of both IP₃ and IP₂ plus IP₁. Thus, pkC activation by TPA very rapidly uncouples the T₁-CD3 complex from phospholipase C activation and PIP₂ hydrolysis. Furthermore, these data do not support the possibility that TPA inhibits net IP₃ formation by stimulation of 5'-phosphomonoesterase activity, as described in platelets (13), because TPA treatment also suppressed, rather than enhanced, receptor-dependent IP₂-plus-IP₁ production (Fig. 5B).

Ca²⁺-independence of T₁-CD3-phospholipase C uncoupling by TPA. In most cellular systems, hormonal activation of phospholipase C does not depend on increases in [Ca²⁺]_i, although phospholipase C activities are often Ca²⁺ sensitive

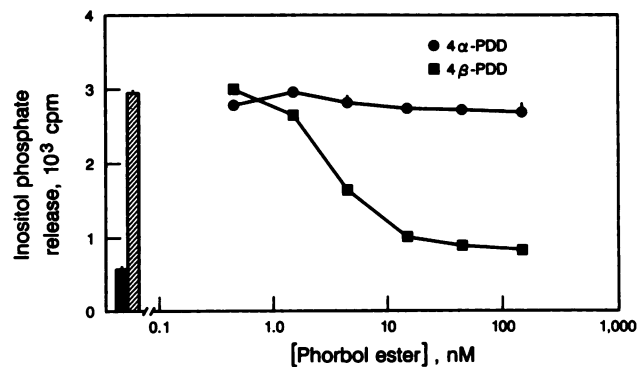

FIG. 4. Differential effects of phorbol ester homologs on PHA-dependent inositol phosphate release. LBRM-33 cells were incubated with 0.3% PHA in the absence (bars) or presence (lines) of the isomeric phorbol esters 4 α -PDD and 4 β -PDD. Bars represent counts per minute (mean \pm standard deviation; $n = 3$) of total inositol phosphate release from unstimulated (stippled bar) or PHA-stimulated cells. Data points represent counts per minute (mean \pm standard deviation) released from PHA-stimulated cells in the presence of the indicated concentrations of phorbol ester. Data shown are representative of two independent experiments.

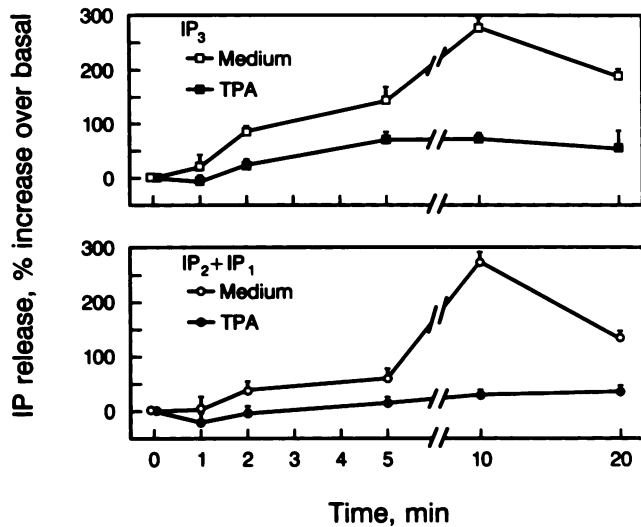

FIG. 5. Effect of TPA on kinetics of IP_3 and IP_2 -plus- IP_1 formation in anti- T_i -CD3 antibody-stimulated cells. LBRM-33 cells (1.5×10^6 cells per sample) were stimulated for the indicated times with KJ16-MAR18.5 antibody complexes in the presence or absence of 1.6 nM TPA. Radiolabeled IP_3 isomers (upper panel) and the total IP_2 -plus- IP_1 fraction (lower panel) were isolated by anion-exchange chromatography as described in Materials and Methods. Data points represent percentage increase (mean \pm standard deviation; $n = 3$) in [3H]inositol phosphate release relative to that of unstimulated controls. Unstimulated controls averaged 82 ± 11 cpm in the IP_3 fraction and 38 ± 1 cpm in the IP_2 -plus- IP_1 fraction.

(10). The possibility remained that the inhibitory effect of TPA on the T_i -CD3-mediated $[Ca^{2+}]_i$ increase was a cause rather than a consequence of the inhibition of receptor-dependent phosphoinositide hydrolysis. This hypothesis was tested by examining the ability of ionomycin to antagonize the inhibitory effect of TPA on KJ16-stimulated inositol phosphate hydrolysis. LBRM-33 cells were stimulated with various combinations of KJ16-MAR18.5 complexes, ionomycin, and TPA, and inositol phosphate release was measured after 20 min of stimulation (Fig. 6). As described previously, TPA (30 nM) decreased the inositol phosphate formation induced by KJ16-MAR18.5 complexes to levels observed in unstimulated LBRM-33 cells. Ionomycin (0.5 μ M) alone had no effect on the hydrolysis of phosphoinositides, which indicated that a $[Ca^{2+}]_i$ increase alone was not sufficient to activate the relevant phospholipase C. Stimulation of LBRM-33 cells with ionomycin plus KJ16-MAR18.5 complexes failed to reverse the inhibitory effect of TPA on T_i -CD3 receptor-stimulated inositol phosphate release. Similar results were observed at both lower (0.2 μ M) and higher (1 μ M) concentrations of ionomycin (data not shown). Thus, the inhibition by TPA of T_i -CD3 receptor-stimulated phospholipase C activity in LBRM-33 cells is not a consequence of the suppression of receptor-dependent $[Ca^{2+}]_i$ increases in LBRM-33 cells.

Effects of TPA on T_i -CD3 expression. Phorbol esters have been shown to induce the internalization of a wide variety of cell surface receptors, including the T_i -CD3 receptor complex (31). The resulting decrease in surface expression of T_i -CD3 provides an obvious mechanism for the negative effect of TPA on T_i -CD3-phospholipase C coupling. Treatment of LBRM-33 cells with 8 nM TPA induced a time-dependent decrease in surface T_i -CD3 expression (apparent $t_{1/2}$, 8 min), as measured by flow cytometric IV analysis with

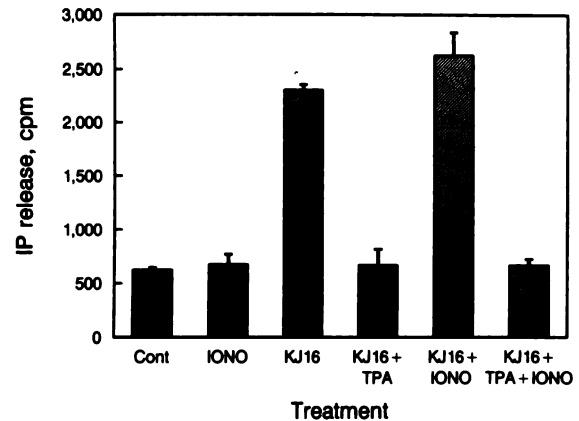

FIG. 6. Evidence that inhibition by TPA of anti- T_i -CD3 antibody-stimulated IP release is independent of $[Ca^{2+}]_i$. LBRM-33 cells (1.5×10^6 cells per sample) were incubated for 20 min with KJ16-MAR18.5 antibody complexes in the absence or presence of various combinations of TPA (30 nM) or ionomycin (IONO) (0.5 μ M). Bars represent total [3H]inositol phosphate release (mean \pm standard deviation; $n = 3$). The data shown are representative of three independent experiments. Cont, Control.

the anti-mouse CD3 antibody 145-2C11 (Fig. 7). As observed previously (31), T_i -CD3 expression in TPA-treated cells plateaued at 40 to 60% of the level in untreated cells. Figure 7B illustrates the effect of increasing TPA concentrations on the level of T_i -CD3 surface expression after 15 min of phorbol ester exposure. Although a concentration-response relationship for T_i -CD3 internalization was apparent, comparison of the approximate IC_{50} for internalization (13 nM) relative to the IC_{50} for TPA inhibition of KJ16-dependent inositol phosphate generation (0.7 nM) demonstrated that the latter response was significantly more sensitive to TPA. Thus, these results suggest that the inhibitory effect of TPA on T_i -CD3-dependent phosphoinositide hydrolysis is due in part to the down-regulation of available binding sites for T_i -CD3 ligands.

Effect of TPA treatment on phospholipase C activities. Phospholipase C activity itself might be inhibited by a pkC-mediated phosphorylation event in TPA-treated LBRM-33 cells. In preliminary experiments (data not shown), we examined the subcellular distribution of phospholipase C activities in LBRM-33 cells. In LBRM-33 cells, all detectable phospholipase C activities were present in the high-speed supernatant prepared from cell sonic extracts, and we have obtained no evidence for G-protein modulation of these activities (data not shown). Subsequently, we examined the effects of various cellular pretreatments on the hydrolysis of [3H]PI and [3H]PIP₂ bilayer vesicles by phospholipase C activities present in crude cytosolic extracts prepared from LBRM-33 cells (Fig. 8). The phospholipase C-dependent hydrolysis of both substrates was shown to be Ca^{2+} dependent; therefore, free Ca^{2+} concentrations were optimized in EGTA-buffered medium to allow maximal hydrolysis of either PI or PIP₂ vesicles by cytosolic extracts from untreated LBRM-33 cells. Under linear reaction conditions, phospholipase C activity against either PI (Fig. 8A) or PIP₂ (Fig. 8B) was not modulated by LBRM-33 cell stimulation with PHA, TPA, or PHA plus TPA before preparation of the cytosolic fractions. Therefore these data indicate that prior activation of pkC in intact cells with PHA or TPA has no direct inhibitory effect on in vitro phospholipase C activities in LBRM-33 cells.

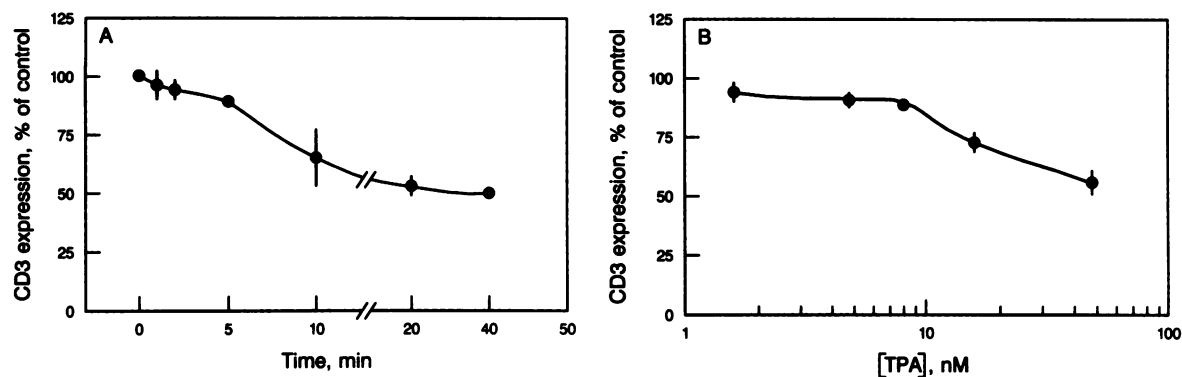

FIG. 7. Effect of TPA on cell surface T_H-CD3 receptor expression. (A) LBRM-33 cells (3×10^6 cells per sample) were treated for the indicated times with 8 nM TPA or (B) with the indicated TPA concentrations for 15 min. Cell surface T_H-CD3 receptor expression was measured by quantitative indirect immunofluorescence with the anti-CD3 antibody 145-2C11 as described in Materials and Methods. Data points represent peak channel fluorescence values (mean \pm standard deviation; two independent experiments) corrected for background (nonspecific) fluorescence in paired controls.

Effect of TPA treatment on T-cell receptor phosphorylation.

Phorbol ester exposure has been shown to induce the rapid phosphorylation of the CD3- γ (gp21) and CD3- ϵ (p25) chains in T cells (31, 40, 41). Because receptor phosphorylation has been shown to regulate both receptor function and internalization rate (28, 31), we examined the effect of TPA on the phosphorylation states of CD3 polypeptides expressed by LBRM-33 cells. The cells were labeled with $^{32}\text{P}_i$, stimulated with various agonists, and immunoprecipitated with a cocktail of F23.1 (anti-T_H heterodimer) and 145-2C11 (anti-CD3- ϵ) monoclonal antibodies. No basal phosphorylation of CD3 polypeptides was detected in immunoprecipitates from unstimulated LBRM-33 cells (Fig. 9A). Stimulation with 0.3% PHA for 10 min (Fig. 9B) induced detectable but relatively low-level phosphorylations of acidic polypeptides with molecular weights identical to those reported for the CD3- γ and - ϵ chains (40). TPA (4.8 nM) alone induced a series of phosphorylation events involving both CD3- γ and CD3- ϵ polypeptides (Fig. 9C). The TPA effect was concentration dependent, with maximal phosphorylation observed at a concentration of 30 nM (data not shown). The resolution of three separate 21-kilodalton phosphoproteins in the first (NEPHGE) dimension reflects the variable sialylation of the γ chain (40, 41). The relatively basic phosphoprotein observed at a slightly lower molecular weight than that of this

γ -chain series appears to represent either an intracellular precursor or a partial proteolytic product of the γ polypeptide. Costimulation of LBRM-33 cells with 0.3% PHA and 4.8 nM TPA yielded an identical phosphorylation pattern; however, the combined stimuli consistently induced a higher level of CD3 phosphorylation than was observed with either stimulus alone (Fig. 9D). Therefore, TPA concentrations that inhibit T_H-CD3-dependent transmembrane signaling concomitantly enhance the pK-dependent phosphorylation of CD3 polypeptides in LBRM-33 cells.

DISCUSSION

Cross-linkage of cell surface T_H-CD3 complexes by antigen-pulsed accessory cells, mitogenic lectins, or anti-T_H-CD3 antibodies results in rapid increases in inositol phospholipid hydrolysis, elevation of $[\text{Ca}^{2+}]_i$, and activation of pK (46). It is generally believed that these early biochemical events provide the requisite signals for T-cell activation and lymphokine production, in part on the basis of the synergistic effects of Ca^{2+} ionophores and phorbol esters as receptor-independent stimuli for these T-cell responses (5). In fact, TPA has been extensively used in T-cell activation studies as a replacement for accessory cell-derived second signals, including IL-1. In this study, we report findings consistent

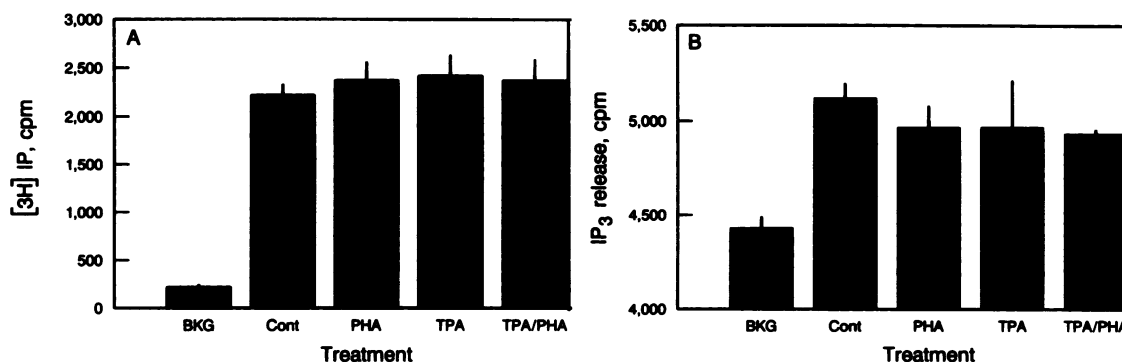

FIG. 8. Effect of TPA treatment on phospholipase C activities in LBRM-33 cells. LBRM-33 cells (40×10^6 cells per sample) were incubated in the absence or presence of PHA (0.3% [vol/vol]) and/or TPA (30 nM) for 10 min. Cytosolic extracts were prepared, and hydrolysis of (A) ^3H PI or (B) ^3H PIP₂ bilayer vesicles was determined under linear reaction conditions as described in Materials and Methods. Bars represent ^3H inositol phosphate released during a 3-min reaction (mean \pm standard deviation). The data shown are representative of at least three independent determinations with each phospholipid substrate.

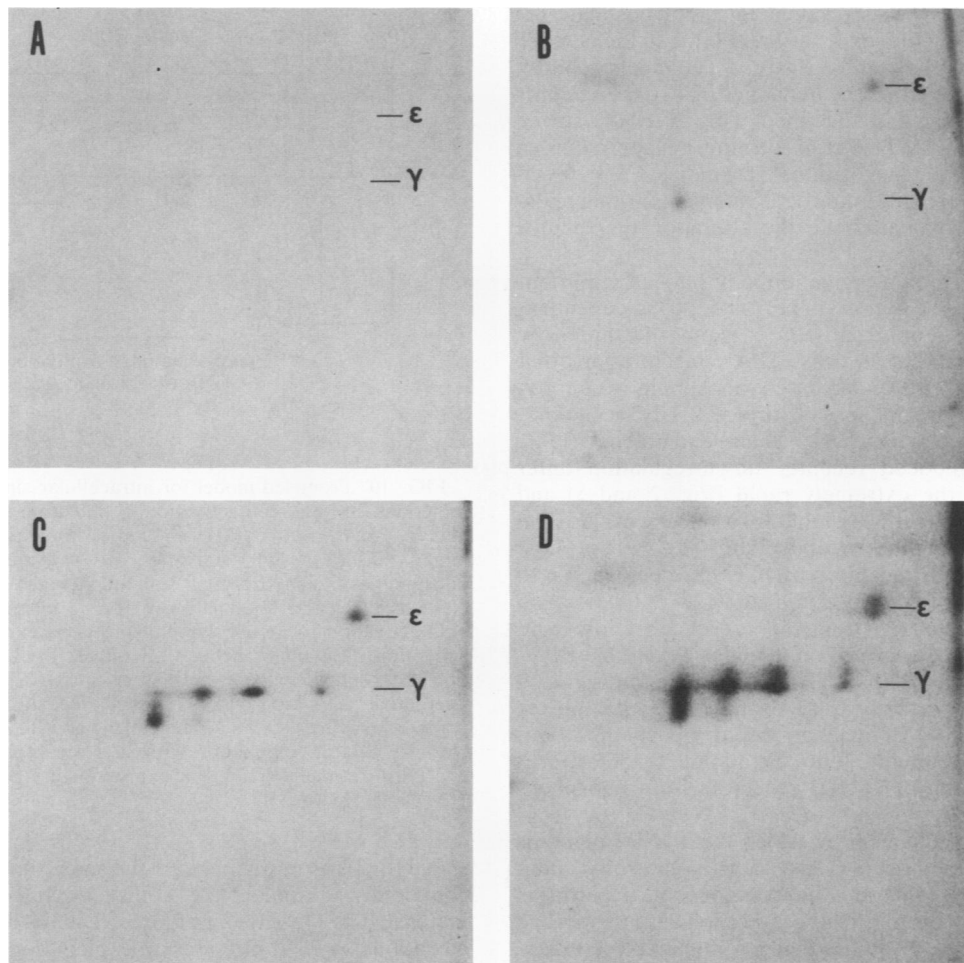

FIG. 9. Stimulation of T_i -CD3 complex phosphorylation by TPA. LBRM-33 cells (50×10^6 cells per sample) were prelabeled with $^{32}P_i$ for 90 min and stimulated for 10 min with (A) no stimuli, (B) 0.3% PHA, (C) 4.8 nM TPA, and (D) 0.3% PHA plus 4.8 nM TPA. Cells were lysed, and T_i -CD3 receptor complexes were immunoprecipitated and subjected to NEPHGE in the first dimension and sodium dodecyl sulfate-polyacrylamide gel electrophoresis on 12.5% acrylamide gels in the second dimension. Phosphoproteins were detected by autoradiography for 4 days. ϵ and γ denote CD3 complex polypeptides identified by molecular weight according to Samelson et al. (40). Autoradiograms represent gel sections containing all specific phosphorylation events detected. Gels are oriented such that pH gradients run from basic (left) to acidic (right). Prestained molecular weight standards were run in parallel with each set of slab gels.

with the notion that TPA and by inference pkC do not function solely in the delivery of a stimulatory signal for T-cell activation. We observed previously that TPA treatment of LBRM-33 cells induced a rapid suppression of PHA-stimulated $[Ca^{2+}]_i$ increases without affecting basal $[Ca^{2+}]_i$ (2). The data reported here suggest that the inhibitory effects of TPA on PHA- or anti- T_i -CD3 antibody-stimulated Ca^{2+} mobilization in LBRM-33 cells are secondary to an inhibition of receptor-dependent phosphoinositide hydrolysis. The rapidity with which TPA uncouples T_i -CD3 stimulation from phospholipase C activation indicates that phosphorylation of one or more of the proximal components of the receptor-transducer-phospholipase C axis results in blockade of the signal relay system. Phorbol esters have been reported to disrupt signal transmission in several other receptor systems. In B lymphocytes, phorbol ester treatment rapidly inhibits both the inositol phosphate release and the Ca^{2+} mobilization induced by cross-linking of surface immunoglobulin M molecules with anti- μ antibodies (32). In BAL17 B lymphoma cells, phosphoinositide hydrolysis is also stimulated by direct activation of cellular G proteins

with the fluoroaluminate complex $[AlF_4]^{1-}$ (33). The demonstration that phorbol ester treatment inhibits $[AlF_4]^{1-}$ -stimulated inositol phosphate release in BAL17 cells (33) implicates either a G protein or phospholipase C itself as a relevant pkC substrate in this system. In contrast, TPA alters the smooth-muscle response to norepinephrine by stimulating phosphorylation of the α_1 -adrenergic receptor, which results in a decrease in receptor affinity for ligand (28). From these studies and others (25, 35, 36), it becomes clear that phorbol esters can perturb stimulus-response coupling in membrane receptor systems by distinctly different molecular mechanisms, depending on the target protein(s) phosphorylated by pkC.

Down-regulation of surface receptor expression represents an obvious mechanism by which pkC-mediated phosphorylation could block signal initiation by cellular receptors. Recently, Minami et al. (31) reported that a 30-min pretreatment with TPA induced a 40 to 60% decrease in T_i -CD3 expression in a T-hybridoma cell line. We observed similar effects of TPA on T_i -CD3 expression in LBRM-33 cells, which suggested that the TPA-mediated suppression of

PHA- or KJ16-MAR18.5-dependent inositol phosphate release could be explained in part by a reduction in the number of receptors accessible to these ligands. The mechanism by which pkC activation alters the dynamics of T_H-CD3 receptor cycling in T cells remains undefined. However, the strong correlation between the TPA concentration-response curves for CD3- γ -chain phosphorylation (31) and T_H-CD3 down-regulation (Fig. 7) provides indirect evidence that this phosphorylation event may underlie the alteration in receptor cycling in T cells.

Although T_H-CD3 down-regulation may play an important role in the suppressive action of TPA on T_H-CD3-dependent signaling, this effect only partially explains the inhibitory effect of TPA on LBRM-33 cells. TPA concentrations that virtually abrogate T_H-CD3-mediated phosphoinositide hydrolysis induce only partial loss of surface T_H-CD3 receptors. Second, the kinetics (apparent $t_{1/2}$, 8 min) and potency (IC₅₀, 13 nM) of TPA-induced receptor down-regulation differ significantly from the extremely rapid (Fig. 2 and 5) and potent (IC₅₀, 0.7 to 2.8 nM) inhibitory effects of TPA on T_H-CD3 receptor coupling to phospholipase C. The phosphorylation of certain receptors by pkC has been shown to result in a decreased affinity for ligand (28); however, no evidence is available regarding the presence of low- and high-affinity T_H-CD3 receptors on T cells. Nonetheless, recent data have shown that TPA is capable of inducing phosphorylation of virtually 100% of the T_H-CD3 complexes expressed by T cells (31), making receptor phosphorylation, with or without concomitant internalization, a tenable mechanism for uncoupling of T_H-CD3 receptors from phospholipase C.

The molecular mechanism by which the T_H-CD3 receptor is coupled to phospholipase C in T cells is currently undefined. Indirect evidence for the presence of a pertussis toxin-insensitive G protein in the T-cell plasma membrane was provided by recent studies using a human T-cell leukemia line, Jurkat (21, 42), and a murine T-cell hybridoma (37) as model systems. In both cell lines, the [AIF₄]¹⁻ complex stimulated rapid increases in phosphoinositide hydrolysis and [Ca²⁺]_i. However, these studies failed to provide evidence for the coupling of this putative G protein to the T_H-CD3 receptor complex. Moreover, treatment of LBRM-33 cells with the [AIF₄]¹⁻ complex does not release inositol phosphates and, in fact, inhibits the response to PHA (R. T. Abraham, unpublished data). Unlike most G-protein-coupled phospholipase C activities defined to date (16), the phospholipase C activities in LBRM-33 are entirely cytosolic in nature. In recent studies of transmembrane signaling through surface immunoglobulin receptors expressed by B lymphocytes, Harris and Cambier (18) have also reported that the relevant phospholipase C activity is localized to the cytosol. Interestingly, this B-cell receptor system demonstrates a similar requirement for multivalent cross-linkage to initiate hydrolysis of inositol phospholipids. Although phospholipase C itself represents an obvious potential target for pkC, the results of this study indicate that PHA or TPA treatment induces no detectable alteration of either PI- or PIP₂-specific phospholipase C enzyme activities in LBRM-33 cells. Clearly, further information on the molecular basis of receptor-phospholipase C coupling in T cells is required, and the potent inhibitor, TPA, represents a potentially powerful tool for these studies.

The complex bidirectional effects of TPA on IL-2 production in LBRM-33 cells are schematized in Fig. 10. Under specific conditions of stimulation, e.g., in the presence of anti-T_H antibodies plus IL-1, TPA clearly delivers a positive

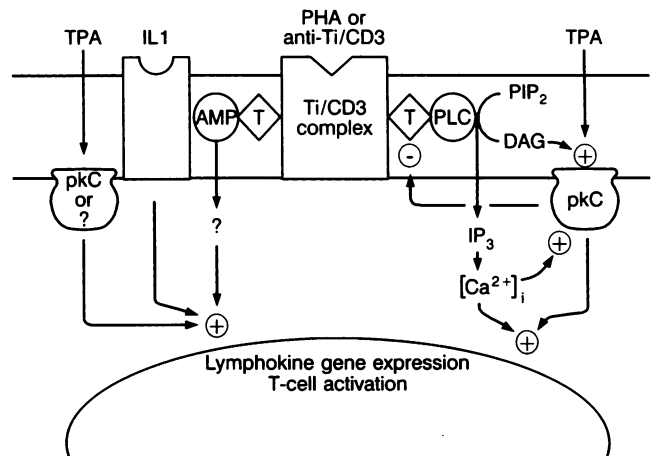

FIG. 10. Proposed model for intracellular signaling pathway interactions during T-cell activation. Stimulation of the T_H-CD3 complex by PHA or anti-T_H-CD3 antibodies initiates, through an undefined transducer (T), activation of phospholipase C (PLC), phosphoinositide hydrolysis, and an increase in [Ca²⁺]_i. In the classical T-cell activation pathway, [Ca²⁺]_i increases synergize with pkC activation to induce lymphokine gene expression and T-cell activation. TPA simultaneously uncouples T_H-CD3 receptor occupation from phospholipase activation and [Ca²⁺]_i increases. The alternative activation pathway, mediated through an undefined amplifier (AMP), is Ca²⁺ independent and TPA insensitive. This pathway acts in conjunction with IL-1 receptor-dependent signals and TPA to stimulate IL-2 gene expression in LBRM-33 cells. DAG, 1,2-Diacylglycerol.

signal for IL-2 production. At the same time, however, TPA completely abrogates the ability of anti-T_H antibodies to increase [Ca²⁺]_i. The inhibition of T_H-CD3-dependent [Ca²⁺]_i elevations by TPA provides an explanation for the failure of TPA to synergize with PHA at 4 h (Fig. 1A) and with the anti-T_H antibodies even after 24 h (Fig. 1C) in the absence of IL-1. PHA alone can synergize with TPA; however, much longer periods of cellular stimulation are required. Taken together, these results strongly suggest that T_H-CD3 stimulation delivers both Ca²⁺-dependent and -independent signals for IL-2 production. The former signaling pathway is mediated through phospholipase C activation and is susceptible to inhibition by TPA, whereas the latter signaling pathway is initiated by an unknown mechanism and is insensitive to TPA. Indeed, TPA itself may trigger biochemical events by mechanisms distinct from pkC activation. Gelfand and co-workers (14) first described the ability of TPA to stimulate a Ca²⁺-independent proliferative response in mitogen-activated T cells. According to our model, IL-1 would provide a requisite costimulus when anti-T_H antibodies are used as primary stimuli in the presence of TPA. Higher concentrations of PHA (0.3 to 1% [vol/vol]) and longer periods of lectin stimulation can at least partially overcome the IL-1 requirement, which is consistent with the ability of these PHA concentrations to deliver both a T_H-CD3 receptor-like first signal and an IL-1-like second signal in LBRM-33 cells (15). The IL-1 requirement for T_H-CD3-dependent IL-2 production in the absence of [Ca²⁺]_i elevations was not simply due to the provision of a Ca²⁺ signal by IL-1. IL-1 alone has no effect on [Ca²⁺]_i in LBRM-33 cells (2), and our recent studies have demonstrated that IL-1 does not override the inhibitory effect of TPA on PHA-dependent phosphoinositide hydrolysis and [Ca²⁺]_i increases (Abraham, unpublished data). Thus, IL-1 appears to modulate the Ca²⁺ sensitivity of

LBRM-33 cells such that T_i -CD3-dependent signals and TPA can drive IL-2 production in the absence of the otherwise requisite receptor-mediated Ca^{2+} signal.

The disruption of T_i -CD3-mediated signal transduction by TPA has several important implications for helper T-cell immunobiology. Because T_i -CD3 receptor cross-linkage itself activates pkC (2), the T_i -CD3 complex stimulation may generate a self-damping negative-feedback signal that limits both phosphoinositide-derived second-messenger release and IL-2 production. Negative-feedback regulation of receptor function has been clearly demonstrated in the β -adrenergic receptor system (43). Recently, we have obtained direct support for this hypothesis by demonstrating that both phosphoinositide hydrolysis and IL-2 production are markedly augmented in PHA-stimulated LBRM-33 cells depleted of pkC by chronic TPA pretreatment (Abraham, unpublished data). The profound desensitizing effects of TPA on T_i -CD3 receptors may have several more physiologic correlates in other T-cell systems, in which nonresponsiveness is elicited by IL-2 (38), immobilized anti- T_i antibodies (34), or fixed antigen-presenting cells (23). Further studies of the mechanisms of T_i -CD3 complex desensitization will, therefore, not only increase our understanding of the molecular mechanisms and regulation of T_i -CD3-dependent signal transduction but also help elucidate the biochemical events that modulate T-cell responses to antigenic stimulation *in vivo*.

ACKNOWLEDGMENTS

This work was supported by a grant from the Fraternal Order of Eagles, by National Science Foundation grant DCB-8616001 (to R.T.A.), by Public Health Service grant CA-42199 from the National Institutes of Health (to D.J.M.), and by a medical scientist scholarship from the Life and Health Insurance Medical Research Fund (to S.N.H.).

We acknowledge the excellent technical assistance of Allan Nilson and the skillful secretarial assistance provided by Kathy Jensen.

LITERATURE CITED

- Abdel-Latif, A. A. 1986. Calcium mobilizing receptors, polyphosphoinositides, and the generation of second messengers. *Pharmacol. Rev.* **38**:227-272.
- Abraham, R. T., S. N. Ho, T. J. Barna, and D. J. McKean. 1987. Transmembrane signaling during IL-1-dependent T cell activation: interactions of signal 1- and signal 2-type mediators with the phosphoinositide-dependent signal transduction mechanism. *J. Biol. Chem.* **262**:2719-2728.
- Abraham, R. T., S. N. Ho, and D. J. McKean. 1987. Bioassay of interleukins. *J. Tissue Culture Methods* **10**:93-99.
- Acuto, O., and E. L. Reinherz. 1985. The human T-cell receptor. *N. Engl. J. Med.* **312**:1100-1111.
- Albert, F., C. Hua, A. Truneh, M. Pierres, and A.-M. Schmitt-Verhulst. 1985. Distinction between antigen receptor and IL2 receptor triggering events in the activation of alloreactive T cell clones with calcium ionophore and phorbol ester. *J. Immunol.* **134**:3649-3655.
- Ashendel, C. L. 1985. The phorbol ester receptor: a phospholipid-regulated protein kinase. *Biochim. Biophys. Acta* **822**:219-242.
- Berridge, M. J. 1984. Inositol triphosphate and diacylglycerol as second messengers. *Biochem. J.* **220**:345-360.
- Bijsterbosch, M. K., C. J. Meade, G. A. Turner, and G. G. B. Klaus. 1985. B lymphocyte receptors and phosphoinositide degradation. *Cell* **41**:999-1066.
- Bradford, M. 1976. A rapid and sensitive method for the quantitation of microgram quantities of protein utilizing the principle of protein-dye binding. *Anal. Biochem.* **72**:248-254.
- Carter, H. R., and A. D. Smith. 1987. Resolution of the phosphoinositide-specific phospholipase C isolated from porcine lymphocytes into multiple species. *Biochem. J.* **244**:639-645.
- Castagna, M., Y. Takai, K. Kaibuchi, K. Sano, U. Kikkawa, and Y. Nishizuka. 1982. Direct activation of calcium-activated, phospholipid-dependent protein kinase by tumor-promoting phorbol esters. *J. Biol. Chem.* **257**:7847-7851.
- Chilson, O. P., A. W. Boyston, and M. J. Crumpton. 1984. *Phaseolis vulgaris* phytohemagglutinin (PHA) binds to the human T lymphocyte antigen receptor. *EMBO J.* **3**:3239-3245.
- Connolly, T. M., W. J. Lawing, and P. W. Majerus. 1986. Protein kinase C phosphorylates human platelet inositol trisphosphate 5'-phosphomonoesterase, increasing the phosphatase activity. *Cell* **46**:951-958.
- Gelfand, E. W., R. K. Cheung, G. B. Mills, and S. Grinstein. 1985. Mitogens trigger a calcium-independent signal for proliferation in phorbol ester treated lymphocytes. *Nature (London)* **315**:419-420.
- Gillis, S., and S. B. Mizel. 1981. T-cell lymphoma model for interleukin 1-mediated T-cell activation. *Proc. Natl. Acad. Sci. USA* **78**:1133-1137.
- Graziano, M. P., and A. G. Gilman. 1987. Guanine nucleotide-binding regulatory proteins: mediators of transmembrane signaling. *Trends Pharmacol. Sci.* **8**:478-481.
- Gryniewicz, G., M. Poenie, and R. Y. Tsien. 1985. A new generation of Ca^{2+} indicators with greatly improved fluorescence properties. *J. Biol. Chem.* **260**:3340-3350.
- Harris, L. K., and J. C. Cambier. 1987. B lymphocyte activation. Transmembrane signal transduction by membrane immunoglobulin in isolated cell membranes. *J. Immunol.* **139**:963-970.
- Haskins, K., C. Hannum, J. White, N. Roehm, R. Kubo, J. Kappler, and P. Marrack. 1984. The major histocompatibility complex-restricted antigen receptor on T cells. VI. An antibody to a receptor allotype. *J. Exp. Med.* **160**:452-471.
- Hepler, J. R., and T. K. Harden. 1986. Guanine nucleotide-dependent pertussis-toxin-insensitive stimulation of inositol phosphate formation by carbachol in a membrane preparation from human astrocytoma cells. *Biochem. J.* **239**:141-146.
- Imboden, J. B., D. Shoback, G. Pattison, and J. D. Stobo. 1986. Cholera toxin inhibits the T-cell antigen receptor-mediated increases in inositol trisphosphate and cytoplasmic free calcium. *Proc. Natl. Acad. Sci. USA* **83**:5673-5677.
- Isakov, N., and A. Altman. 1987. Human T lymphocyte activation by tumor promoters: role of protein kinase C. *J. Immunol.* **138**:3100-3107.
- Jenkins, M. K., D. M. Pardoll, J. Mizuguchi, T. M. Chused, and R. M. Schwartz. 1987. Molecular events in the induction of a nonresponsive state in interleukin 2-producing helper T-lymphocyte clones. *Proc. Natl. Acad. Sci. USA* **84**:5409-5413.
- Kamisaka, Y., S. Toyoshima, and T. Osawa. 1986. Phosphatidylinositol-specific phospholipase C of murine lymphocytes. *Arch. Biochem. Biophys.* **249**:569-578.
- Kikuchi, A., K. Ikeda, O. Kozawa, and Y. Takai. 1987. Modes of inhibitory action of protein kinase C in the chemotactic peptide-induced formation of inositol phosphates in differentiated human leukemic (HL-60) cells. *J. Biol. Chem.* **262**:6766-6770.
- Ledbetter, J. A., C. H. June, P. J. Martin, C. E. Spooner, J. A. Hansen, and K. E. Meier. 1986. Valency of CD3 binding and internalization of the CD3 complex control T cell responses to second signals: distinction between effects on protein kinase C, cytoplasmic free calcium, and proliferation. *J. Immunol.* **136**:3945-3952.
- Lee, K.-Y., S. H. Ryu, P.-G. Suh, W. C. Choi, and S. G. Rhee. 1987. Phospholipase C associated with particulate fractions of bovine brain. *Proc. Natl. Acad. Sci. USA* **84**:5540-5544.
- Leeb-Lundberg, L. M. F., S. Cotecchia, A. DeBlasi, M. G. Caron, and R. J. Lefkowitz. 1987. Regulation of adrenergic receptor function by phosphorylation. *J. Biol. Chem.* **262**:3098-3105.
- Leo, O., M. Foo, D. H. Sachs, L. E. Samelson, and J. A. Bluestone. 1987. Identification of a monoclonal antibody specific for a murine T3 polypeptide. *Proc. Natl. Acad. Sci. USA* **84**:1374-1378.

30. Mills, G. B., R. K. Cheung, S. Grinstein, and E. W. Gelfand. 1985. Increase in cytosolic free calcium concentration is an intracellular messenger for the production of interleukin 2 but not for interleukin 2 receptor. *J. Immunol.* **134**:1640-1643.
31. Minami, Y., L. E. Samelson, and R. D. Klausner. 1987. Internalization and cycling of the T cell antigen receptor. Role of protein kinase C. *J. Biol. Chem.* **262**:13342-13347.
32. Mizuguchi, J., M. A. Beaven, J. H. Li, and W. E. Paul. 1986. Phorbol myristate acetate inhibits anti-IgM-mediated signaling in resting B cells. *J. Immunol.* **83**:4474-4478.
33. Mizuguchi, J., J. Yong-Yong, H. Nakabayashi, K.-P. Huang, M. A. Beaven, T. Chused, and W. E. Paul. 1987. Protein kinase C blocks anti-IgM-mediated activation in BAL17 B lymphoma cells. *J. Immunol.* **139**:1054-1059.
34. Nau, G. J., R. J. Moldwin, D. W. Lancki, D.-K. Kim, and F. W. Fitch. 1987. Inhibition of IL2-driven proliferation of murine T lymphocyte clones by supraoptimal levels of immobilized anti-T cell receptor antibody. *J. Immunol.* **139**:114-122.
35. O'Flynn, K., M. Russal-Saib, I. Ando, D. L. Wallace, P. C. L. Beverley, A. W. Boyston, and D. C. Linch. 1986. Different pathways of human T-cell activation revealed by PHA-P and PHA-M. *Immunology* **57**:55-60.
36. Orellana, S., P. A. Solski, and J. Heller Brown. 1987. Guanosine 5'-O-(thio-triphosphate)-dependent inositol trisphosphate formation in membranes is inhibited by phorbol ester and protein kinase C. *J. Biol. Chem.* **262**:1638-1643.
37. O'Shea, J. J., K. B. Urdahl, H. T. Luong, T. M. Chused, L. E. Samelson, and R. D. Klausner. 1987. Aluminum fluoride induces phosphatidylinositol turnover, elevation of cytoplasmic free calcium, and phosphorylation of the T cell antigen receptor in murine T cells. *J. Immunol.* **139**:3463-3469.
38. Otten, G., D. B. Wilde, M. B. Prystowsky, J. S. Olshan, H. Rabin, L. E. Henderson, and F. W. Fitch. 1986. Cloned helper T lymphocytes exposed to interleukin 2 become unresponsive to antigen and concanavalin A but not to calcium ionophore and phorbol ester. *Eur. J. Immunol.* **16**:217-225.
39. Roehm, N., L. Herron, J. Cambier, D. DiGiusto, K. Haskins, J. Kappler, and P. Marrack. 1984. The major histocompatibility complex restricted antigen receptor on T cells: distribution on thymus and peripheral T cells. *Cell* **38**:577-584.
40. Samelson, L. E., J. B. Harford, and R. D. Klausner. 1985. Identification of the components of the murine T cell antigen receptor complex. *Cell* **43**:223-231.
41. Samelson, L. E., M. D. Patel, A. M. Weissman, J. B. Harford, and R. E. Klausner. 1986. Antigen activation of murine T cells induces tyrosine phosphorylation of a polypeptide associated with the T cell antigen receptor. *Cell* **46**:1083-1090.
42. Sasaki, T., and H. Hasegawa-Sasaki. 1987. Activation of a polyphosphoinositide phospholipase C by guanosine 5'-O-(3-thio)triphosphate and fluoroaluminate in membranes prepared from human T cell leukemia line, Jurkat. *FEBS Lett.* **218**:87-92.
43. Sibley, D. R., and R. J. Lefkowitz. 1985. Molecular mechanisms of receptor desensitization using the β -adrenergic receptor-coupled adenylate cyclase system as a model. *Nature (London)* **317**:124-129.
44. Staerz, V. D., and J. M. Bevan. 1985. An allotypic determinant on the murine T cell antigen receptor, p. 61-64. *In* J. W. Streilein, F. Ahmad, S. Black, B. Blomberg, and R. W. Voellmy (ed.), *Molecular biology of the immune system*. Cambridge University Press, Cambridge.
45. Watson, J. 1979. Continuous proliferation of murine antigen-specific helper T lymphocytes in culture. *J. Exp. Med.* **150**:1510-1519.
46. Weiss, A., J. Imboden, K. Hardy, B. Manger, C. Terhorst, and J. Stobo. 1986. The role of the T3/antigen receptor complex in T-cell activation. *Annu. Rev. Immunol.* **4**:593-620.
47. Zlotnik, A., and B. Daine. 1986. Activation of IL1-dependent and IL1-independent T cell lines by calcium ionophore and phorbol ester. *J. Immunol.* **136**:1033-1037.
48. Zlotnik, A., B. Daine, and C. A. Smith. 1985. Activation of an interleukin-1 responsive T-cell lymphoma by fixed P388D1 macrophages and an antibody against the Ag:MHC receptor. *Cell. Immunol.* **94**:447-453.