

Photoreduction and Oxidation of Cytochrome *f* in Bundle Sheath Cells of Maize

Received for publication July 26, 1971

D. G. BISHOP, KIRSTEN S. ANDERSEN,¹ AND ROBERT M. SMILLIE

Plant Physiology Unit, Commonwealth Scientific and Industrial Research Organization, Division of Food Research, and School of Biological Sciences, Macquarie University, North Ryde 2113, Sydney, Australia

ABSTRACT

The photo-oxidation of cytochrome *f* (cytochrome c_{554}) in bundle sheath cells isolated from leaves of maize (*Zea mays* var. DS 606A) has been compared with that in intact maize leaf and in isolated pea leaf cells (*Pisum sativum* L.). In all cases, illumination with red light caused a negative absorbance change at 554 nm which was attributed to the oxidation of cytochrome *f*. The extent of this change was greater using monochromatic red light at wavelengths above 700 nm compared with wavelengths below 700 nm. 3-(3,4-Dichlorophenyl)-1,1-dimethylurea abolished this difference in bundle sheath cells. After illumination for 1 minute or longer in bundle sheath cells, reduction of cytochrome *f* in the dark was rapid only if the wavelength of the illuminating light was below 700 nm. In the presence of 3-(3,4-dichlorophenyl)-1,1-dimethylurea, reduction was slow after illumination at all wavelengths.

Cytochrome *f* photo-oxidation was also followed in cells of a mutant of *Chlamydomonas reinhardi*, *ac-21*, which has isolated chloroplasts that exhibit photochemical reactions similar to those shown by isolated bundle sheath chloroplasts. No evidence was obtained for photoreduction of cytochrome *f* in the mutant.

It was concluded that in the chloroplast of the intact bundle sheath cell of maize there is electron flow between photosystem II and cytochrome *f* resulting in photoreduction of the cytochrome.

important implications to the elucidation of the pathway of carbon in C4 plants and has been the subject of much recent debate (7).

One approach to this problem has been made by Edwards *et al.* (6), who have studied photosynthetic CO₂ fixation in separated but intact bundle sheath cells isolated from leaves of crabgrass (*Digitaria sanguinalis*). We have used another experimental approach, namely, to study the effect of wavelength of the illuminating light upon the photo-oxidation of cytochrome *f* (cytochrome c_{554}) in intact bundle sheath cells of maize as a means of obtaining evidence for electron transfer between photosystem II and photosystem I in the intact cell. The photo-oxidation of cytochrome *f* is associated with photosystem I (4), and, in chloroplasts which contain grana, the oxidized cytochrome is reduced by reductants produced in photosystem II. If there is also electron flow in the agranal chloroplasts of bundle sheath cells between photosystem II and cytochrome *f*, photo-oxidation of the cytochrome should vary depending on whether the light given is absorbed by photosystems I and II (<700 nm) or by photosystem I only (>700 nm). The photo-oxidation of cytochrome *f* in isolated bundle sheath chloroplasts of maize and *Sorghum* is independent of wavelength (1, 12), but chloroplasts in intact bundle sheath cells have not been examined.

MATERIALS AND METHODS

Seeds of maize (*Zea mays* var. DS 606A) and pea (*Pisum sativum* L.) were germinated in moist vermiculite, and the seedlings were raised in a greenhouse. Leaves were harvested from 14-day-old seedlings. Intact bundle sheath cells were prepared from maize leaves by the method of Woo *et al.* (12), and intact mesophyll cells were prepared by maceration (11) of pea leaves. The bundle sheath cells were not separated from each other but were essentially free of mesophyll cells (1).

Measurement of cytochrome *f* photo-oxidation was made on intact maize leaf and on suspensions of maize bundle sheath cells and pea leaf cells with an Aminco-Chance dual wavelength spectrophotometer (American Instrument Co.). The temperature was 23 C. The concentration of the cell suspension was adjusted so that an absorbance change of about 0.002 at 554 nm was obtained upon illumination with red light. Monochromatic red light was obtained from a tungsten lamp filtered through a Bausch and Lomb interference filter and a Corning 2-60 red cutoff and two Corning 1-69 filters. Light intensity was measured with a radiometer (YSI-Kettering, model 65).

Cells of *Chlamydomonas reinhardi*, wild type and the mutant *ac-21* (originally obtained from Professor R. P. Levine), were grown as described previously (9).

The chloroplasts of plants possessing the Hatch-Slack or C4 pathway of photosynthesis (C4 plants) often show distinct differences in structure, composition, and photosynthetic activities compared to chloroplasts from plants containing the Calvin cycle (C3 plants) (7). Several of the C4 plants, including maize, *Sorghum*, and sugar cane, are characterized by chloroplasts which show little evidence of grana development in the cells surrounding the vascular bundle. Chloroplasts isolated from these cells do not photoreduce NADP (1-3, 12), even though they contain demonstrable photosystem I and photosystem II activities (1-3). These and related observations (5) have raised the question of whether in the intact cell the bundle sheath chloroplasts are capable of photosynthetically reducing NADP, as is thought to occur in the grana-containing chloroplasts found in C3 plants and in the mesophyll cells of C4 plants. The answer to this question has

¹ Visiting scientist from Institute of Genetics, Copenhagen University, Øster Farimagsgade 2A, DK1353, Denmark.

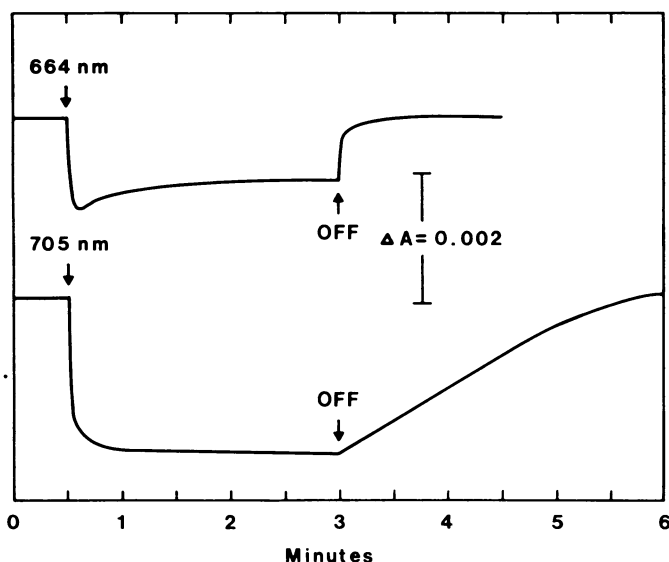

FIG. 1. Light-induced absorbance change at 554 nm in a suspension of maize bundle sheath cells. The light intensities at 664 and 705 nm were 5.5 and 5.8×10^8 ergs $\text{cm}^{-2} \text{sec}^{-1}$, respectively. The reference wavelength was 541 nm.

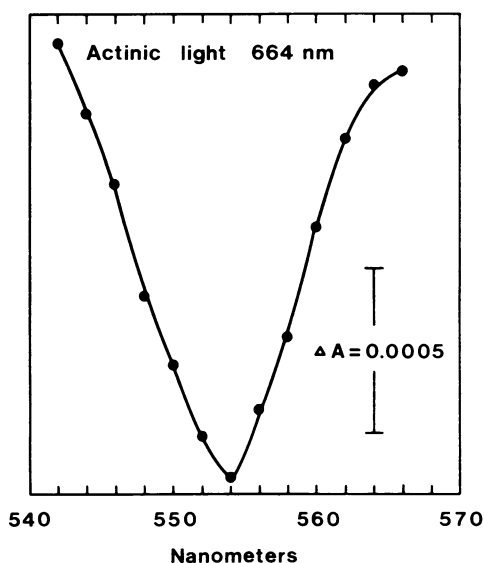

FIG. 2. Spectrum of absorbance change in bundle sheath cells brought about by monochromatic light at 664 nm (5.2×10^8 ergs $\text{cm}^{-2} \text{sec}^{-1}$).

RESULTS

Photo-oxidation of Cytochrome *f* in Whole Maize Leaf. An analysis of the absorbance changes at 554 nm in the fully expanded portion of a maize leaf after illumination indicated that, in the leaf, cytochrome *f* was reduced by photosystem II and oxidized by photosystem I. For instance, the magnitude of the absorbance change at 554 nm with 664-nm light, which is absorbed by both photosystems I and II, was 10% of the change obtained using 705-nm light of equal intensity, which is absorbed predominantly by photosystem I. Thus reductants produced in photosystem II were affecting the steady state level of oxidation of the cytochrome. The intact leaf, however, contains both mesophyll and bundle sheath cells, and the changes observed may have been

mainly localized in the mesophyll cells. To see if the oxidation of cytochrome *f* in the chloroplasts of bundle sheath cells was also influenced by light absorbed by photosystem II, we made similar measurements with a suspension of isolated bundle sheath cells in which there was no significant contamination by intact mesophyll cells.

The Effect of Wavelength upon Cytochrome Changes in Isolated Intact Bundle Sheath Cells. Figure 1 shows the absorbance change at 554 nm when a suspension of bundle sheath cells was illuminated with monochromatic red light. The absorbance changes measured at various wavelengths of the measuring beam indicated that the change was due to oxidation of cytochrome *f* (Fig. 2). While light at both 664 and 705 nm caused a rapid decrease in absorbance at 554 nm, the magnitude of the change at 664 nm was smaller (Fig. 1). Further, with 664-nm light, there was an increase in absorbance to a less oxidized steady state after 10 sec of illumination. This was more pronounced with light at 641 nm. The smaller absorbance change with 664-nm light compared to that with 705-nm light is consistent with an effect on cytochrome *f* of light absorbed by photosystem II. In this case the difference between the absorbance changes with 664- and 705-nm light should be abolished by the addition of DCMU, an inhibitor of photosystem II. Table I shows the absorbance changes at 554 nm, both before and after the addition of DCMU, using light at several wavelengths. Red light or monochromatic light below 700 nm produced a smaller absorbance change than monochromatic light above 700 nm. After treatment of the cell suspension with DCMU, the absorbance change at 554 nm was independent of wavelength of the illuminating light and corresponded to the change produced by light absorbed by photosystem I only before treatment with DCMU.

Another difference between illumination with 664- and 705-nm light can be seen in the postillumination absorbance change. At all wavelengths, after a few seconds of illumination, there was a rapid reduction of cytochrome *f*. With longer periods of illumination, however, reduction in the dark was slow after illumination at wavelengths above 700 nm ($t_{1/2} = 0.7$ – 1.4 min) while it remained fast at wavelengths below 700 nm ($t_{1/2} \sim 2$ sec) (see Fig. 1). This difference is abolished by DCMU. After 2 min of illumination the dark reduction of cytochrome *f* is slow in the presence of DCMU at all wavelengths and above 700 nm in the absence of DCMU.

Absorbance Changes at 554 nm in Isolated Pea Leaf Cells. The isolation of bundle sheath cells may possibly cause some

Table I. Effect of Treatment of Bundle Sheath Cells with DCMU upon Photo-oxidation of Cytochrome *f*

| Light | | Change in Absorbance | |
|------------------------|--|--|-------------------|
| Wavelength | Intensity | No DCMU | DCMU ¹ |
| nm | ergs $\text{cm}^{-2} \text{sec}^{-1} \times 10^{-3}$ | $\Delta (A_{554} - A_{541}) \times 10^4$ | |
| 641 | 5.8 | 4.3 | 18 |
| 664 | 5.5 | 12 | 19 |
| 693 | 5.8 | 14 | 19 |
| 705 | 5.8 | 21 | 19 |
| 725 | 5.8 | 18 | 17 |
| Red light ² | 69 | 11 | 18 |

¹ DCMU (6 μM) was added to a suspension of bundle sheath cells, and measurements were commenced after 15 min.

² Light from a tungsten lamp filtered through a Corning 2-60 red cutoff filter.

metabolic changes in the cells, and attempts were made to isolate mesophyll cells from maize leaves so a comparative study of light-induced changes could be made. Procedures employing grinding (6) or maceration (11) were unsuccessful in obtaining intact maize mesophyll cells, and, instead, comparative experiments were carried out using a suspension of separated intact mesophyll cells from pea leaves. Red light induced a rapid decrease in absorbance at 554 nm, and as in the case of the bundle sheath cells the change was smaller at wavelengths below 700 nm (Fig. 3). In contrast to maize bundle sheath cells, the low rate of increase in absorbance after illumination for a minute or longer at wavelengths above 700 nm was not seen.

Light-induced Changes of Cytochrome *f* in a Mutant of *Chlamydomonas*. Chloroplast fragments isolated from the wild type cell of *C. reinhardi* can photoreduce NADP from water (9). However, chloroplasts from a mutant of this organism, *ac-21*, show many of the same characteristics exhibited by chloroplasts isolated from maize bundle sheath cells. Chloroplasts from the *ac-21* mutant do not photoreduce NADP although both photosystem I and photosystem II activities are present (9). Also, like isolated bundle sheath chloroplasts, the photoreduction of cytochrome *f* in isolated *ac-21* chloroplast fragments is independent of the wavelength of the incident light (8). In wild type cells photo-oxidation of cytochrome *f* can be affected by varying either the wavelength of the incident light or its intensity. Figure 4 compares the photo-oxidation of cytochrome *f* as a function of the light intensity in wild type cells and in cells of the mutant *ac-21*. As the intensity of the 700-nm light illuminating the wild type cells is decreased the photoreduction of cytochrome from photosystem II becomes increasingly evident. In the case of the *ac-21* mutant, there is no evidence of photoreduction of the cytochrome.

DISCUSSION

The site of cytochrome *f* in photosynthetic electron transfer is between photosystems I and II, the cytochrome being reduced by reductants produced in photosystem II and photo-oxidized by photosystem I (4). In illuminated chloroplasts isolated from maize or *Sorghum* mesophyll and bundle sheath cells, cytochrome *f* is oxidized, but in the case of bundle sheath chloroplasts there is no dependence upon wavelength of the incident red light (1, 12). A parallel can be found in chloroplasts isolated from wild type *C. reinhardi* and the *ac-21* mutant. Wild type chloroplasts, like mesophyll chloroplasts, show a wavelength dependence at the red end of the spectrum for cytochrome *f* oxidation, whereas chloroplasts from the *ac-21* mutant, which like bundle sheath chloroplasts cannot photoreduce NADP (9) although photosystems I and II are present (8), show no such dependence on wavelength. From measurements made on cells of *C. reinhardi* this same lack of dependence on wavelength for cytochrome *f* oxidation appears to hold for the intact cell of the *ac-21* mutant (Fig. 4). However, in the bundle sheath cell the situation is quite different. There is a definite effect of wavelengths below 700 nm on cytochrome *f* oxidation compared with wavelengths above 700 nm. The changes observed are similar to those obtained with a suspension of pea leaf cells prepared by a technique designed to release mesophyll cells from dicotyledonous leaves (11). This dependence upon wavelength in the bundle sheath cells is abolished by DCMU (Table I).

The main difference noted between cytochrome *f* changes in maize bundle sheath and pea leaf cells was the slow dark reduction of cytochrome *f* in the former after a period of

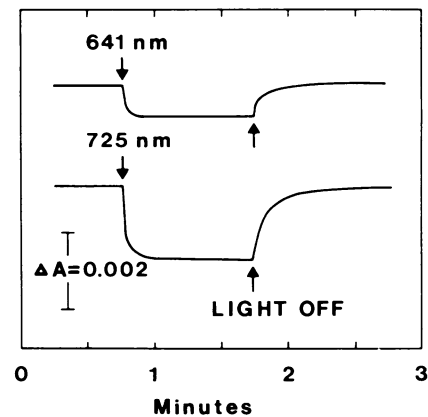

FIG. 3. Absorbance changes at 554 nm in a suspension of pea leaf cells upon illumination with 641- and 725-nm light. Incident intensity was 5.8×10^8 ergs $\text{cm}^{-2} \text{sec}^{-1}$.

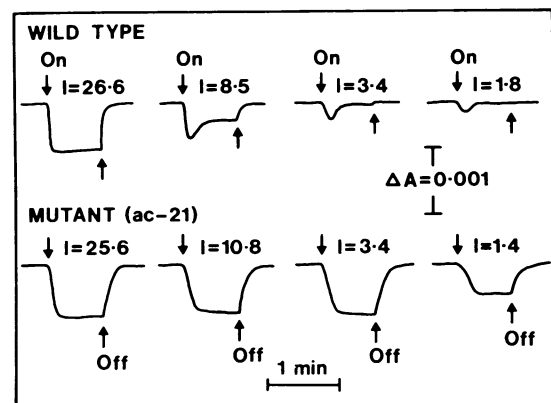

FIG. 4. Light-induced changes at 554 nm in cells of *C. reinhardi*, wild type and the mutant *ac-21*. The wavelength of the light used was 700 nm and the intensities (I) shown are in ergs $\text{cm}^{-2} \text{sec}^{-1}$. The reference wavelength of the spectrophotometer was set at 570 nm.

extended illumination. The slow dark reduction in the bundle sheath cells appeared to be due to exhaustion of readily available reductants for cytochrome *f* reduction during illumination by light which is absorbed predominantly by photosystem I. If the light is absorbed by photosystem II also, then a pool of reductants is replenished (presumably produced in photosystem II since the effect is abolished by DCMU). The difference between bundle sheath and pea leaf cells may stem from the fact that the intensities of the monochromatic light used, while being close to saturation for photosystem I as well as for photosystem II in grana-containing chloroplasts, were well below saturation for photosystem II of bundle sheath chloroplasts, as saturation is not achieved until very high intensities ($>2 \times 10^8$ ergs $\text{cm}^{-2} \text{sec}^{-1}$) are reached (unpublished results). Thus, in the case of pea leaf cells, there may be enough "leakage" of light above 700 nm into photosystem II to allow accumulation of sufficient reductants for rapid dark reduction of cytochrome *f*, whereas, in the bundle sheath cells (because the system is operating below light saturation), the light absorbed by photosystem II with wavelengths above 700 nm is too small to appreciably affect the dark reduction of cytochrome *f*.

Our results then indicate that in the intact bundle sheath cells of maize cytochrome *f* is reduced by reductants produced in photosystem II and oxidized in photosystem I. There are two important consequences of this conclusion.

Firstly, it lends support to the notion that agranal bundle sheath cells of C4 plants can, in fact, photoreduce NADP. Secondly, it suggests that a possible reason for the inability of isolated bundle sheath chloroplasts to photoreduce NADP is due to a deficiency (not shared by the isolated mesophyll chloroplast) in one or more soluble components which are necessary to link photosystem II to reactions leading to the reduction of ferredoxin via photosystem I. This possibility is investigated in an accompanying paper (10).

Acknowledgment—The authors gratefully acknowledge the technical assistance of Ann Bartsch.

LITERATURE CITED

- ANDERSEN, K. S., J. M. BAIN, D. G. BISHOP, AND R. M. SMILLIE. 1972. Photosystem II activity in agranal bundle sheath chloroplasts from *Zea mays*. *Plant Physiol.* 49: 461-466.
- BISHOP, D. G., K. S. ANDERSEN, AND R. M. SMILLIE. 1971. Incomplete membrane-bound photosynthetic electron transfer pathway in agranal chloroplasts. *Biochem. Biophys. Res. Commun.* 42: 74-81.
- BISHOP, D. G., K. S. ANDERSEN, AND R. M. SMILLIE. 1971. The distribution of galactolipids in mesophyll and bundle sheath chloroplasts of maize and *Sorghum*. *Biochim. Biophys. Acta* 231: 412-414.
- BOARDMAN, N. K. 1968. The photochemical systems of photosynthesis. *Advan. Enzymol.* 30: 1-79.
- DOWNTON, W. J. S., J. A. BERRY, AND E. B. TREGUNNA. 1970. C4-photosynthesis: non-cyclic electron flow and grana development in bundle-sheath chloroplasts. *Z. Pflanzenphysiol.* 63: 194-198.
- EDWARDS, G. E., S. S. LEE, T. M. CHEN, AND C. C. BLACK. 1970. Carboxylation reactions and photosynthesis of carbon compounds in isolated mesophyll and bundle sheath cells of *Digitaria sanguinalis* (L.) Scop. *Biochem. Biophys. Res. Commun.* 39: 389-395.
- HATCH, M. D., C. B. OSMOND, AND R. O. SLATYER (eds.). 1971. Photosynthesis and Photorespiration. John Wiley Interscience, New York.
- LEVINE, R. P. AND D. S. GORMAN. 1966. Photosynthetic electron transport chain of *Chlamydomonas reinhardtii*. III. Light-induced absorbance changes in chloroplast fragments of the wild type and mutant strains. *Plant Physiol.* 41: 1293-1300.
- LEVINE, R. P. AND R. M. SMILLIE. 1963. The photosynthetic electron transport chain of *Chlamydomonas reinhardtii*. *J. Biol. Chem.* 238: 4052-4057.
- SMILLIE, R. M., K. S. ANDERSEN, N. F. TOBIN, B. ENTSCH, AND D. G. BISHOP. 1972. Nicotinamide adenine dinucleotide phosphate photoreduction from water by agranal chloroplasts isolated from bundle sheath cells of maize. *Plant Physiol.* 49: 471-475.
- TAKEBE, I., Y. OTSUKI, AND S. AOKI. 1968. Isolation of tobacco mesophyll cells in intact and active state. *Plant Cell Physiol.* 9: 115-124.
- WOO, K. C., J. M. ANDERSON, N. K. BOARDMAN, W. J. S. DOWNTON, C. B. OSMOND, AND S. W. THORNE. 1970. Deficient photosystem II in agranal bundle sheath chloroplasts of C4 plants. *Proc. Nat. Acad. Sci. U. S. A.* 67: 18-25.