



Published in final edited form as:

J Biomed Opt. 2008 ; 13(3): 034009. doi:10.1117/1.2937476.

Protoporphyrin IX fluorescence photobleaching increases with the use of fractionated irradiation in the esophagus

Brian W. Pogue,

Dartmouth College, Thayer School of Engineering, Hanover New Hampshire 03755 and Dartmouth Medical School Department of Surgery Hanover New Hampshire 03755 and Harvard Medical School, Massachusetts General Hospital, Wellman Center for Photomedicine Boston, Massachusetts 02114

Chao Sheng,

Dartmouth College, Thayer School of Engineering, Hanover, New Hampshire 03755

Juan Benevides,

Dartmouth Medical School, Department of Surgery, Hanover, New Hampshire 03755

David Forcione,

Dartmouth Medical School, Department of Surgery, Hanover, New Hampshire 03755

Bill Puricelli,

Harvard Medical School, Massachusetts General Hospital, Wellman Center for Photomedicine, Boston, Massachusetts 02114

Norm Nishioka, and

Harvard Medical School, Massachusetts General Hospital, Wellman Center for Photomedicine and Department of Medicine Boston, Massachusetts 02114

Tayyaba Hasan

Harvard Medical School, Massachusetts General Hospital, Wellman Center for Photomedicine Boston, Massachusetts 02114

Abstract

Fluorescence measurements have been used to track the dosimetry of photodynamic therapy (PDT) for many years, and this approach can be especially important for treatments with aminolevulinic-acid-induced protoporphyrin IX (ALA-PpIX). PpIX photobleaches rapidly, and the bleaching is known to be oxygen dependent, and at the same time, fractionation or reduced irradiance treatments have been shown to significantly increase efficacy. Thus, *in vivo* measurement of either the bleaching rate and/or the total bleaching yield could be used to track the deposited dose in tissue and determine the optimal treatment plans. Fluorescence in rat esophagus and human Barrett's esophagus are measured during PDT in both continuous and fractionated light delivery treatment, and the bleaching is quantified. Reducing the optical irradiance from 50 to 25 mW/cm did not significantly alter photobleaching in rat esophagus, but fractionation of the light at 1-min on and off intervals did increase photobleaching up to 10% more (p value=0.02) and up to 25% more in the human Barrett's tissue (p value<0.001). While two different tissues and two different dosimetry systems are used, the data support the overall hypothesis that light fractionation in ALA-PpIX PDT esophageal treatments should have a beneficial effect on the total treatment effect.

Keywords

fluorescence; photodetection; fiber optic sensors; photodynamic therapy; fiber optics; targets

1 Introduction

Recently, 5-aminolevulinic acid (ALA) has increased in usage as a prodrug for photosensitization, and there are promising data for its clinical use in skin and mucosally related diseases. ALA is metabolized within tissue to form the photosensitizer (PS) molecule protoporphyrin IX (PpIX) and partly owes its application to the selectivity with which PpIX is formed within cancerous tissue, and also to the ease of use in topical and oral administration of ALA itself. However, a major limiting factor in the useful application of photodynamic therapy (PDT) with PpIX is the rapid photobleaching that is known to occur.¹ In this paper, the use of ALA-PpIX-based PDT is examined with a particular focus on the issue of how much photobleaching occurs in the course of therapy, and if the photobleaching is affected by the method of light administration. While there are limited data on this subject in humans, due to the limited use of dosimetry instrumentation in these treatments, it may be possible to improve the significance of this effect by comparing the sum of pertinent data from human and rodent measurements.

The kinetics of photobleaching are actually quite complex, as the initial decay appears to be oxygen dependent.² Thus, while basic cellular studies of the bleaching have provided fundamental insight, the implementation of real *in vivo* dosimetry through this approach has been a little more elusive, because of the complex dynamics between PSs and oxygen.³ It is well known that PpIX is photobleached quickly,^{4,5} yet it is also well established that there is a later phase during PDT when the bleaching rate is substantially lower than the initial rate, which is presumably due to the absence of oxygen.^{1,6} The bleaching rate also appears to have some information about the photochemical deposition, which could be exploited. Independent of the real underlying physical chemistry, a system for real-time control of bleaching is essential to providing some intelligent and dynamic feedback control of the PDT process in the esophagus.

However, another confounding factor in these measurements is that the photobleaching *in vivo* by fluorescence can be artifactually contaminated by a depth-dependent bleaching, where initially there is a loss of intensity in the upper tissue layers, and fluorescence decays at a slower rate due to detection of emission from lower tissue layers.^{7,8} To minimize this effect, it has been shown that detection of the fluorescence from very small sampling fibers can restrict this effect in the measured data.^{1,9-11} However, PpIX is actually only weakly fluorescent, and it has a small Q-band absorption peak at 633 nm. When excited by visible light, PpIX will produce fluorescence with a peak around 645 nm and with a secondary peak near 700 nm. Figure 1 shows the spectrum of PpIX both before and after 10-J/cm² irradiation to the solution. Measuring fluorescence from PpIX is a well-developed method for dosimetric measurements,^{1,6,12-14} and in this paper, the small fiber-optic-based system was used to produce real-time “microsampling” of photosensitizer tissue fluorescence^{11,15,16} in a manner that is not highly affected by the tissue optical properties.

To noninvasively measure PpIX during PDT, there are two possible ways to sample the signal, either actively or passively during the therapy. In an active dosimeter, the probe light is applied to the tissue, possibly with some lock-in detection approach to sampling where the applied light dose is intermittently turned on to induce fluorescence.^{10,11} In passive dosimetry, the fluorescence is directly measured during treatment illumination, recording the emission signal continuously during the entire treatment.¹ While active dosimetry has been

approved and used in our clinical center for some time, the use of passive dosimetry has not been, and so remains an experimental protocol. However, the use of passive dosimetry, while technically challenging, can provide a much richer temporal data set, as values are acquired throughout the entire treatment. Thus, here we compare active dosimetry values for human studies with passive dosimetry values for rodent studies.

The goal of this study was predominantly to examine the available data to determine if the photobleaching rate is affected during changes in light delivery, and if that change was mirrored in the animal versus human data available. Eventually this information could be useful to impact the treatment efficacy, since the rate of photobleaching^{1,6} is expected to be correlated to the treatment effect.

2 Materials and Methods

2.1 Passive Esophageal Dosimetry System

A second design for an esophageal dosimetry system was constructed, to “passively” measure the porphyrin fluorescence (i.e., proportional to active concentration) during PDT light treatment. The dosimeter has capability for six input fibers from six different sites of the esophagus. In this design, the fluorescent signals excited by the treatment laser at a 635-nm wavelength and would be acquired by the fiber tips which are attached to the treatment balloon. The optical signals that contain porphyrin fluorescence signal (fluorescence channel measurement) and the treatment laser signal (reference channel measurement) are separated by a splitter and then measured by two different photomultiplier tubes (PMTs) (Fig. 2). These signals from different sites are recorded sequentially in a rapid cycling manner. Relative to the PpIX fluorescence spectrum excited by a 635-nm laser, two filters (620- to 650-nm bandpass filter for the reference channel and a 690-nm high-pass filter for the fluorescence channel) are placed before the PMTs to reduce crosstalk between the two optical channel signals and eliminate the noise.

Both the PpIX fluorescence signal and the PDT treatment laser signal were acquired by diffused end tip fibers. The diffused end tip is 1 cm long with a diameter of 200 μm . Two different kinds of probes were used for signal acquisition. For large animal studies (not reported here), a balloon probe was used [Fig. 2(a)] with detection fibers attached to the balloon membrane at up to six different positions. After the probe is inserted into the esophagus and reaches the treatment area, the balloon probe is inflated and the detection fibers are closely attached to the esophagus; thus, those fibers would acquire both signal intensity and signal spatial information. For small-animal studies, a single detection fiber was attached right beside the PDT irradiation fiber.

The detection fibers were lined to a 6-to-1 fiber coupler. Right before the coupler, six shutter sets were introduced. Each shutter consisted of a mechanical block, two collimators, and an aluminum holder. The shutter was controlled by Lab-VIEW to open/block the optical path between two collimators. Each of the six input fibers of the coupler were 200 μm and the output fiber was 800 μm , which is lined to the optical collimator [Fig. 2(c)]. By sequentially opening and closing each shutter, the signal from six different detection fibers are sent to the PMT via this single optical pathway.

The optical signal from the detection fiber contained both PDT treatment laser information (around 635 nm) and PpIX fluorescence information. The photoproduct of PpIX (most likely the result of PpIX photobleaching) yields fluorescence with a peak around 670 nm of 10-nm bandwidth, and thus it can be challenging to separate this from the 700-nm peak of PpIX. As illustrated in Fig. 2(b), the photons from the detection fiber hit a dichroic mirror and are divided into two difference channels. The reference channel had a 620- to 650-nm bandpass

filter right before the PMT. This reference channel was required to measure the PDT treatment laser (635-nm) intensity. The fluorescence channel used a 690-nm long-pass filter right before the PMT, to block both the excitation laser and the photoproduct fluorescence.

Two separate photomultipliers (Model HC120, Hamamatsu Inc.) were used to measure the optical signals. The PMT gains were fixed at 0.6 and 0.8 V for reference and fluorescence channels, respectively, as these provided a measurable range from 0 to 1.0 V. The current signals coming from PMTs were amplified and acquired as a voltage using a standard 12-bit data acquisition card (National Instruments DAQ 2064E) which was addressed through LabVIEW.

2.2 Passive Dosimetry System Calibration in Liquid Phantoms

As the dosimeter system was constructed, a series of calibration studies in liquid phantoms were designed to verify the consistency of the dosimeter, and to investigate the correlation between the PDT treatment laser output power and reference channel signal, and also to investigate the correlation between PpIX concentration and fluorescence channel signals.

Liquid phantoms were made up of different concentrations of Intralipid, ink, and PpIX. A mixture of 1% Intralipid approximately equals the reduced scattering coefficient of $\mu'_s=1.1 \text{ mm}^{-1}$, with 1% of the 100:1 diluted ink solution is approximately equal to an absorption coefficient of $\mu_a = 0.025 \text{ mm}^{-1}$ at 635 nm. To simulate the measurement in esophageal tissue, phantoms were made to approximately the same optical properties expected in tissue, with values of $\mu'_s=1.1 \text{ mm}^{-1}$ and $\mu_a = 0.04 \text{ mm}^{-1}$. Liquid phantoms were held in 15-ml plastic tubes with a total volume of 10 ml.

2.3 Animal Experiments

The Dartmouth College Animal Care and Use Committee (IACUC) approved all animal work in this study. Sprague-Dawley rats were purchased from Charles River Laboratories (Wilmington, Massachusetts), at 6 weeks old and housed in cages under standard laboratory conditions (room temperature, $22\pm 2^\circ \text{ C}$; relative humidity, $55\% \pm 5\%$; and 12-h light/dark cycle).

The animals were a subset of a larger study with normal Sprague-Dawley rats, with a total of 28 used here. Animals were randomized into four groups and ALA was administered at different doses [intraperitoneal (ip) at 50 mg/kg]. After a 2-h incubation time, the rat esophagus was irradiated with a 633-nm laser. The irradiation was delivered into the lower esophagus through a 1 cm long diffusing tip fiber. A total of 20 J/cm linear irradiance was delivered to each rat with different fluence rates (25 or 50 mW/cm) and different laser irradiation methods (continuous irradiation or fractionated irradiation with a 1-min laser on/off interval). During the treatment, rats were anaesthetized with ketamine (90 mg/kg) and xylazine (10 mg/kg). The passive fluorescence dosimeter was used during the PDT treatment; both local laser fluence rate and PpIX fluorescence were monitored. The initial values and final values are used in this report.

Four PDT treatment groups were studied:

1. **Group 1** ($n = 8$) with 50-mg/kg ALA administration dose and 20-J/cm light irradiation at the fluence rate of 50 mW/cm (continuous treatment)
2. **Group 2** ($n = 5$) with 50-mg/kg ALA administration dose and 20-J/cm light irradiation at the fluence rate of 25 mW/cm (continuous treatment)

3. **Group 3** ($n = 7$) with 50-mg/kg ALA administration dose and 20-J/cm light irradiation at the fluence rate of 50 mW/cm (fractionated treatment)
4. **Group 4** ($n = 9$) with 50-mg/kg ALA administration dose and 20-J/cm light irradiation at the fluence rate of 25 mW/cm (fractionated treatment).

The passive esophagus dosimeter was used in the esophagus beside the treatment fiber during the PDT light delivery. This dosimeter could monitor both irradiation light fluence rate and PpIX fluorescence. The system is illustrated in Fig. 2, however, only one detection sensor was used in the rat esophagus study. After rats were anaesthetized, both the PDT irradiation fiber and dosimeter detection fiber were inserted down to rat lower esophagus together. During PDT treatment, measurements were taken every 10 s. The treatment laser fluence rate was measured through a 620- to 650-nm bandpass filter, and the PpIX fluorescence was measured through a 690-nm longer pass filter. The dual PMT detection of this dosimeter was used to provide simultaneous acquisition of the signals, and correction for laser intensity fluctuations.

2.4 Clinical Active Photosensitizer Dosimetry

While the passive dosimeter has been successfully used in animals, it is not yet approved for human use, and therefore it is not possible to obtain continuous measurement of the fluorescence during treatment. The clinical dosimetry system *in vivo* was developed and demonstrated in previous studies.^{11,15,17-19} Briefly, the system uses blue light (405 nm wavelength) excitation and very small optical fibers (100 μm core diameter) to limit the penetration and distance traveled by light that is detected. The light that is captured from the tissue must have originated within a few scattering distances (typically 100 to 300 μm) of the fibers surface for significant probability of detection. This enables the signal to be linearly proportional to the fluorophore concentration and not significantly affected by variations in tissue optical properties.¹¹ The original design was proposed for surface measurements and the working end, which took measurements from the tissue, was designed to be 6 mm across. This end consisted of a set of seven fiber bundles, each having seven individual fibers, where the middle fiber delivered the excitation light and the surrounding ring of six fibers collected the fluorescence. Each set of fibers was separated from each other one by more than a millimeter to enable minimal crosstalk between them. This dosimeter system has been used here for esophageal measurements using a smaller single fiber, consisting of only a single set of seven fibers, with the inner fiber carrying the excitation and the outer six fibers picking up the emission.

Sampling of the fluorescence uses approximately 1 mW of total power, and lock-in detection with the light cycled on and off at 200 Hz. The signal is calibrated to be linearly proportional to typical *in vivo* concentrations of PpIX, and normal acquisition requires about 0.5 s. Due to the light sensitivity of this instrument, it cannot be used during laser therapy, without additional filtering optics.

This dosimetry system was produced through NCI sponsorship and three such dosimeters are in use at the biomedical laboratories of Massachusetts General Hospital (clinical and preclinical use), Cleveland Clinic (clinical and preclinical use), and Dartmouth Hitchcock Medical Center (preclinical use only). Due to the fact that the treatment beam must be turned off during acquisition, there are fluorescence data only for before and after therapy for clinical studies.

2.5 Clinical PDT Treatment and Fluorescence Dosimetry

Human studies were carried out at the Massachusetts General Hospital under an Institutional Review Board (IRB)-approved protocol for Barrett's esophagus PDT. Six subjects were

recruited into this arm of the study and baseline fluorescence measurements of the buccal mucosa were taken using the active fluorescence dosimeter. Patients were then given a solution of ALA in orange juice to take orally (30 mg/kg ALA by body weight). Following a 4-h incubation period, patients received topical anesthesia to numb the pharynx as well as intravenous sedation. Pre-PDT irradiation measurements of PpIX levels were taken of the Barrett's tissue and surrounding normal sites using the fluorescence dosimeter. Postirradiation measurements were taken of the treated sites with the Aurora to measure PpIX levels. Biopsy samples of the diseased and normal tissue were also obtained at the pre- and posttreatment times.

A 5-mm diffusing optical fiber nested in a cylindrical balloon dilator (Fig. 1) was then used to deliver 635-nm light from a KTP/YAG XP 800 dye laser (Laserscope, San Jose, California) to the esophageal lumen. The 5-mm radially diffusing optical fiber was placed within an 18-mm-diam clear cylindrical balloon dilator, so that the fiber was at the center of the esophageal lumen, providing even distribution of the light to the esophageal lumen. A total fluence of 150 J/cm^2 , at a tissue surface irradiance of 150 mW/cm^2 , was delivered either continuously or as a fractionated dose (60-s light/dark intervals).

The fluorescence dosimeter was used to measure PpIX fluorescence levels in the patient tissue. A 405-nm diode laser provides the excitation light to a fiber optic bundle composed of one excitation fiber surrounded by six fluorescence emission collection fibers with a total diameter of 0.1 in. at the distal tip.

2.6 Statistical Analysis

In all analyses of fluorescence changes examined here, a one-tailed t test was used, with two-sample unequal variance. The differences in fluorescence pre- and posttreatment were mainly examined for differences, to determine if photobleaching was significant.

3 Results

3.1 Passive Dosimeter Calibration and Correction for Crosstalk

A total of three sets of liquid phantoms were made with $\mu'_s = 1.1 \text{ mm}^{-1}$ and $\mu_a = 0.04 \text{ mm}^{-1}$, but no PpIX was added in phantoms. The detection fiber was inserted into the center of the liquid. Laser outputs were set at 0, 14, 21, 32, 67, 128, and 165 mW/cm, and measurements were taken at each of these levels.

As illustrated in Fig. 3(a), the reference channel PMT output signals (voltage) had linear correlation with laser outputs. Since 25, 50, and 100 mW/cm are the most used laser powers for ALA-PpIX PDT treatment in the esophagus, our phantom study demonstrated a reliable laser dosimeter in our system. The reading from the reference channel PMT could be used to calculate the PDT light dose.

From the light dosimeter calibration phantom study, it was also noticed that even without any PpIX inside the phantoms, there still were some readings from the fluorescence channel PMT. This was concluded to be crosstalk from the irradiation laser, assuming the 690 longer pass filter could not block all photons in the range of 620 to 690 nm. To investigate the crosstalk between reference channel and fluorescence channel, a new set of phantom studies was designed.

A total of four sets of phantoms were made. Considering that there could be some optical variations in individual targets, absorption coefficient μ_a was different in each phantom ($\mu_a = 0.0125, 0.025, 0.04, \text{ and } 0.05 \text{ mm}^{-1}$). Reduced scattering coefficient μ'_s was still set at 1.1

mm^{-1} for all phantoms and no PpIX was added into the phantoms. Laser outputs were set at 32, 67, and 128 mW/cm, and measurements were taken at each of these settings.

As seen in Fig. 3(b), the results showed that the crosstalk from the reference channel was linearly increasing with the laser output, yet the crosstalk was also very consistent as the optical properties varied within the pertinent range of possible values. These data were fitted into a linear function $y = kx + b$, where the reference channel (x) to fluorescence channel (y) crosstalk functions were $y = 0.108x + 0.068$ ($\mu_a = 0.0125 \text{ mm}^{-1}$), $y = 0.110x + 0.062$ ($\mu_a = 0.025 \text{ mm}^{-1}$), $y = 0.112x + 0.060$ ($\mu_a = 0.04 \text{ mm}^{-1}$), and $y = 0.118x + 0.059$ ($\mu_a = 0.05 \text{ mm}^{-1}$), respectively. The slope rate k had 3.8% variation, while b has 6% variation, indicating that these calibration lines could work for a broad range of tissue optical properties. With this consistent linear crosstalk function, readings from the fluorescence channel could be adjusted according to reference channel readings and the crosstalk could be effectively corrected for.

To investigate the correlation between detected fluorescence signal and the actual PpIX concentration, eight sets of liquid phantoms were made with same optical properties (and $\mu_a = 0.04 \text{ mm}^{-1}$). A total of eight different concentrations of $\mu'_s = 1.1 \text{ mm}^{-1}$ PpIX were added into phantoms (0, 0.1, 0.2, 0.3, 0.5, 1.0, 2.0, and 3.0 $\mu\text{g/ml}$, respectively). Irradiation laser output was set at 50 mW/cm and six measurements were taken for each phantom.

The readings are illustrated in Fig. 3(c), with the fluorescence showing positive correlation with PpIX concentration, while the reference channel readings did not. Reference channel readings varied $\pm 4\%$ and decreased a little while the PpIX concentration (fluorescence intensity) increasing significantly. This minor decrease of reference channel signal was reasonable with the assumption that the PpIX would affect the phantom absorption coefficient somewhat. From the consistency of the reference channel readings, it was assumed that the crosstalk from the fluorescence channel to the reference channel was a minor factor. Only crosstalk from reference channel to fluorescence channel must be addressed.

Using the measured crosstalk function, $y = 0.112x + 0.060$, to adjust the fluorescence channel readings for this minor correlation, the corrected results are shown in Fig. 3(d). A linear relationship between the fluorescence channel signal (after crosstalk adjustment) and the PpIX concentrations was observed. It was encouraging that this passive dosimetry system could detect down to a 0.1- $\mu\text{g/ml}$ difference in the PpIX concentrations, while the linear range included from 0 to 4.0 $\mu\text{g/ml}$, which was also the *in vivo* PpIX concentration range expected in tissue.

3.2 Animal Data

The full fluorescence kinetic change was examined in detail in a previous study, but here the focus is on the initial versus final fluorescence intensity values. There was a change in signal level from all animals studied in this work, and the average values for each treatment group are shown in Fig. 4(a). This illustrates the fluorescence signal in esophagus, for a fixed ALA ip administration dose of 50 mg/kg, with a 2-h incubation time. The fluorescence intensity changes were 15 ± 2 , 10 ± 3 , 25 ± 3 , and 21 ± 4 , respectively, for the 50-mW/cm continuous group, the 25-mW continuous group, the 50-mW/cm fractionated group, and the 25-mW/cm fractionated group. Interestingly, the lower fluence rates did not cause less photobleaching than the higher ones, based on a one-tailed t test analysis of the average data. However, the light fractionation groups both had significant increases in the photobleaching, with p values of 0.02 and 0.016 for the 50- and the 25-mW/cm groups, respectively.

3.3 Clinical Data

Relative to post-ALA, pre-PDT fluorescence measurements, a significant decrease in PpIX fluorescence levels was observed in Barrett's tissue that received either continuous illumination ($49\% \pm 5\%$) versus the fractionated illumination ($74\% \pm 12\%$) (Fig. 5). The fractionated illumination caused significantly more photobleaching than continuous illumination (p value < 0.001). PpIX fluorescence levels did not change in the oral cavity and normal squamous control sites, as might be expected, since these areas were not irradiated with light. However, measurement of these tissues provides a simple internal control measurement for each subject. Biopsies of the Barrett's tissue taken 4 h after administration of ALA, just before treatment with light, showed a heterogeneous distribution of PpIX fluorescence in the metaplastic tissue as confirmed by histology in a parallel tissue section (Fig. 6).

4 Discussion

As expected during PDT, the fluorescence signal from the rat esophagus decreased in all cases, and the effect was greatest in the fractionated delivery cases, confirming previous reports of a greater photobleaching effect when the treatment delivery was lengthened. The increase in photobleaching was subtle in the case of rodent data (approximate 10% increase in bleaching), and more pronounced in the human data (approximate 25% increase in bleaching). Interestingly in the case of 25-versus 50-mW/cm linear irradiance change, the amount bleached did not significantly change, indicating that likely even lower linear irradiances might be required to increase this effect. However, the inconsistency between the effect observed with fractionation versus the effect not observed with decreased irradiance is difficult to fully understand. It is possible that some biological or biochemical effects occur in response to the light-off fractions, which are not present when continuous lower irradiance illumination is used. While treatment effect could not be objectively evaluated in the patient studies, the rodent work in this paper, combined with the previous study, would indicate that greater photobleaching corresponds to more damage to the tissue, and hence a superior treatment effect.

The two dosimetry systems were used without difficulty, and with sufficient dynamic range to make them useful for routine dosimetry in clinical situations. The dosimetry could actually be carried out with both active and passive measurement if need be. The main technological requirement is simply working out the logistics of how to attach the fibers to the exterior of the treatment balloon. In prototype studies, this was done reasonably well with RTV-based glue, and several device manufacturers have potential solutions for this type of delicate attachment. The performance of the two dosimeters in terms of SNR and repeatability were not directly compared here, but have quite different issues in terms of use. The active dosimeter used blue light, so the issues of crosstalk were considerably less in that system, because the optical filtering of blue light from the emission red light is efficient and provides a strong signal. The passive dosimeter must rely on the treatment light for excitation and therefore uses red excitation and red-to-near-IR emission, and the crosstalk in this type of system is inevitable. The calibration procedure used for minimization of the crosstalk was efficient for our purposes and led to a repeatable signal with low enough detection efficiency. Both systems were sensitive enough to be used in physiologically known values of ALA-induced PpIX, but the active dosimeter can likely be optimized for better sensitivity, because of the blue excitation yielding significantly higher fluorescence, and the better ability to filter the excitation from emission light. However, a direct comparison of the two was not done here.

There was not a significant difference in the treatment plan between the two PDT studies of humans and rodents, since the light doses were similar. However, a weakness in the

comparison done here is that the measurement in the human system was done with a blue-light-based dosimeter, whereas the measurement in the rodent was done with the red-treatment-light-based dosimeter. It is likely that the upper layers of the esophagus mucosa bleach more quickly, and this decay is more readily observed with a blue-light-based dosimeter. The red-light-generated signal would have a signal from a deeper mixture of depths. Alternatively, it is possible that the human tissue had greater oxygenation and blood supply, enabling it to be more effectively bleached away, but this hypothesis remains to be tested fully. Future work could focus on a more mechanistic study of photobleaching with the two types of systems, and examine the bleaching in the layers of the esophagus. Unfortunately, the experiment is very difficult, if not impossible, to do in the human case where the esophagus thickness and complexity is greatest.

Conclusions

The two dosimetry systems used here for esophageal measurements worked, and appeared to give similar trends in their data in terms of fluorescence signals and photobleaching in response to therapy. The use of reduced linear irradiance in the esophagus from 50 to 25 mW/cm did not have a significant effect on the photobleaching yield in the rodent model. However, light fractionation on and off at 1-min intervals had a significant photobleaching effect in both the rodent normal esophagus and the human Barrett's esophagus treatments. The increased photobleaching is generally thought to be indicative of a more complete treatment, since it is oxygen dependent, and past studies have shown that the integrated fluorescence during the photobleaching phase is linearly related to the damage done in the tissue. Further studies could focus on either combinations of dosimetry with both blue and red light to take measurements or more mechanistic studies to quantify the bleaching in different.

Acknowledgments

This work has been sponsored by National Institutes of Health (NIH) funding PO1CA84203 and through the Wellman Center Graduate Scholarship Fund at the Massachusetts General Hospital.

References

1. Sheng C, Hoopes PJ, Hasan T, Pogue BW. Photobleaching-based dosimetry predicts deposited dose in ALA-PpIX PDT of rodent esophagus. *Photochem Photobiol.* 2007; 83:738–748. [PubMed: 17576383]
2. Georgakoudi I, Foster TH. Singlet oxygen- versus nonsinglet oxygen-mediated mechanisms of sensitizer photobleaching and their effects on photodynamic dosimetry. *Photochem Photobiol.* 1998; 67(6):612–625. [PubMed: 9648527]
3. Robinson DJ, de Bruijn HS, van der Veen N, Stringer MR, Brown SB, Star WM. Protoporphyrin IX fluorescence photobleaching during ALA-mediated photodynamic therapy of UVB-induced tumors in hairless mouse skin. *Photochem Photobiol.* 1999; 69(1):61–70. [PubMed: 10063801]
4. Robinson DJ, de Bruijn HS, van der Veen N, Stringer MR, Brown SB, Star WM. Fluorescence photobleaching of ALA-induced protoporphyrin IX during photodynamic therapy of normal hairless mouse skin: the effect of light dose and irradiance and the resulting biological effect. *Photochem Photobiol.* 1998; 67(1):140–149. [PubMed: 9477772]
5. Moan J, Peng Q, Sorensen R, Iani V, Nesland JM. The biophysical foundations of photodynamic therapy. *Endoscopy.* 1998; 30(4):387–391. [PubMed: 9689514]
6. Boere IA, Robinson DJ, de Bruijn HS, Kluin J, Tilanus HW, Sterenberg HJCM, de Bruin RWF. Protoporphyrin IX fluorescence photobleaching and the response of rat Barrett's esophagus following 5-aminolevulinic acid photodynamic therapy. *Photochem Photobiol.* 2006; 82(6):1638–1644. [PubMed: 16879035]

7. Hyde DE, Farrell TJ, Patterson MS, Wilson BC. A diffusion theory model of spatially resolved fluorescence from depth-dependent fluorophore concentrations. *Phys Med Biol.* 2001; 46(2):369–383. [PubMed: 11229720]
8. Juzenas P, Juzeniene A, Kaalhus O, Iani V, Moan J. Noninvasive fluorescence excitation spectroscopy during application of 5-aminolevulinic acid in vivo. *Photochem Photobiol Sci.* 2002; 1(10):745–748. [PubMed: 12656473]
9. Pogue BW, Gibbs SL, Chen B, Savellano M. Fluorescence imaging in vivo: raster scanned point-source imaging provides more accurate quantification than broad beam geometries. *Technol Cancer Res Treat.* 2004; 3(1):15–21. [PubMed: 14750889]
10. Pogue BW, Burke G, Lee CC, Hoopes PJ. Photosensitizer quantitation in vivo by fluorescence micro-sampling. *Proc SPIE.* 2000; 3914:33–39.
11. Pogue BW, Burke GC. Fiber optic bundle design for quantitative fluorescence measurement from tissue. *Appl Opt.* 1998; 37(31):7429–7436. [PubMed: 18301577]
12. Hewett J, Nadeau V, Ferguson J, Moseley H, Ibbotson S, Allen JW, Sibbett W, Padgett M. The application of a compact multispectral imaging system with integrated excitation source to in vivo monitoring of fluorescence during topical photodynamic therapy of superficial skin cancers. *Photochem Photobiol.* 2001; 73(3):278–282. [PubMed: 11281024]
13. Nadeau V, O'Dwyer M, Hamdan K, Tait I, Padgett M. In vivo measurement of 5-aminolaevulinic acid-induced protoporphyrin IX photobleaching: a comparison of red and blue light of various intensities. *Photodermatol Photoimmunol Photomed.* 2004; 20(4):170–174. [PubMed: 15238094]
14. Sudworth CD, Stringer MR, Cruse-Sawyer JE, Brown SB. Fluorescence microspectroscopy technique for the study of intracellular protoporphyrin IX dynamics. *Appl Spectrosc.* 2003; 57(6):682–688. [PubMed: 14658702]
15. Lee CC, Pogue BW, Burke GC, Hoopes PJ. Comparison of photosensitizer (AIS2Pc) quantitation techniques: in situ fluorescence microsampling versus tissue chemical extraction. *Photochem Photobiol.* 2001; 74(3):453–460. [PubMed: 11594060]
16. Sheng C, Pogue BW, Wang E, Hutchins JE, Hoopes PJ. Assessment of photosensitizer dosimetry and tissue damage assay for photodynamic therapy in advanced-stage tumors. *Photochem Photobiol.* 2004; 79(6):520–525. [PubMed: 15291303]
17. Pogue BW, Chen B, Zhou X, Hoopes PJ. Analysis of sampling volume and tissue heterogeneity upon the in vivo detection of fluorescence. *J Biomed Opt.* 2005; 10:041206.
18. Zhou X, Pogue BW, Chen B, Hasan T. Analysis of effective molecular diffusion rates for verteporfin in subcutaneous versus orthotopic Dunning prostate tumors. *Photochem Photobiol.* 2004; 79(4):323–331. [PubMed: 15137508]
19. Lee CC, Pogue BW, O'Hara JA, Wilmot CM, Straw-bridge RR, Burke GC, Hoopes PJ. Spatial heterogeneity and temporal kinetics of photosensitizer (AIPcS2) concentration in murine tumors RIF-1 and MTG-B. *Photochem Photobiol Sci.* 2003; 2(2):145–150. [PubMed: 12664976]

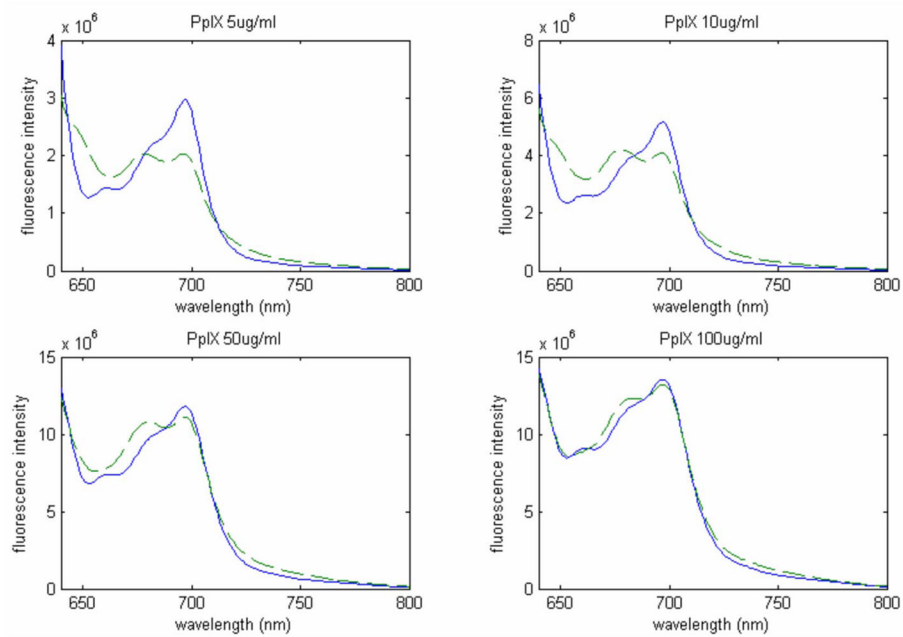

Fig. 1. Emission spectrum (excited at 635 nm) of PpIX in saline. The solid lines are the PpIX spectrum before PDT irradiation. Dashed lines are fluorescence [which likely includes photoproduct(s) from the PpIX molecular photobleaching] spectrum after 10-J/cm^2 PDT irradiation. The PpIX photobleaching product is known to have a fluorescence peak around 670 nm, while PpIX itself has a fluorescence peak around 700 nm.

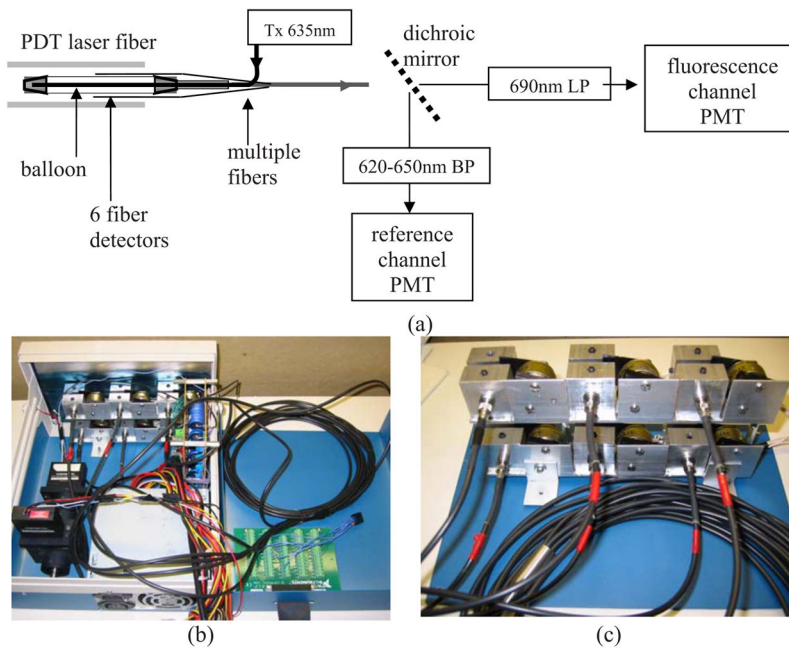
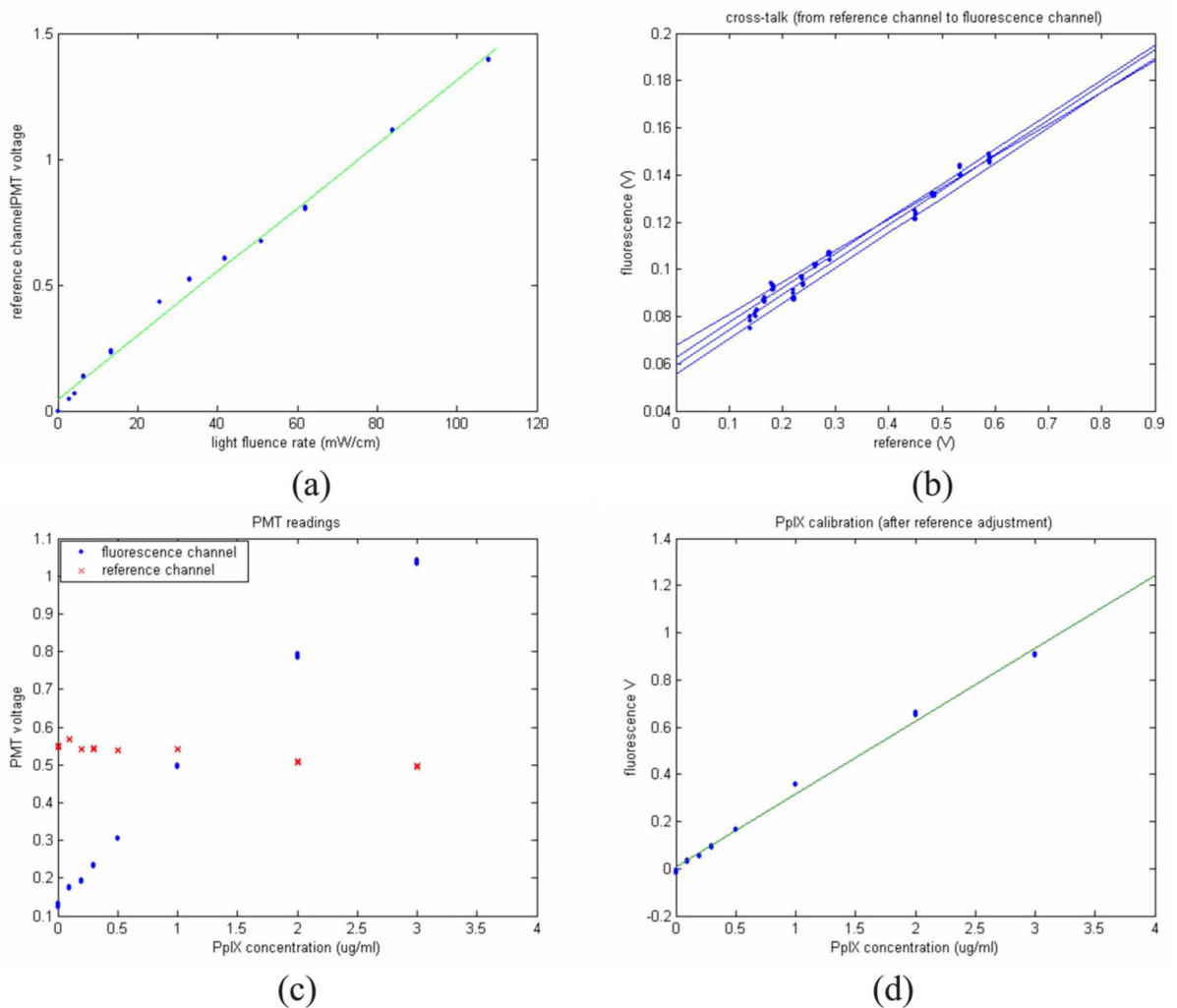
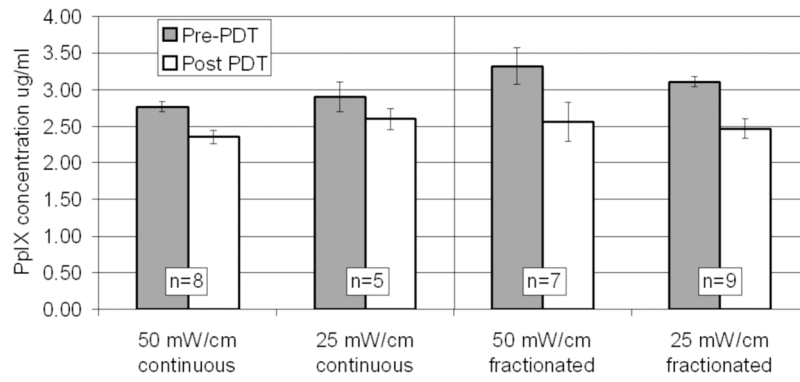

Fig. 2.

Dosimetry system structure is outlined in (a), including a brief illustration of the fiber excitation at 635 nm and the way to split the signal of the detection fibers into 690 long-pass and 620 to 650 bandpass, enabling simultaneous detection and rationing. (b) and (c) The key hardware components of the dosimetry system, including the 6-to-1 optical switch (b), PMT detector [lower-left in (b)], electronic control board [lower-middle in (b)], and the DAQ (data acquisition) card (lower-right). PpIX has a fluorescence peak around 700 nm, and the peaks at 660 and 680 are thought to be photoproducts whose signal, and so emission, is collected through a 690-nm long-pass filter. The detection part includes two PMTs for the optical signals of excitation light and PpIX fluorescence.

**Fig. 3.**

(a) Correlation of the reference channel signal to the laser output, as measured in a liquid phantom with linear irradiances of 0 to 165 mW/cm; (b) crosstalk from the reference channel to the fluorescence channel shown from a set of phantoms (fixed transport scattering $\mu'_s = 1.1 \text{ mm}^{-1}$) with different absorption coefficient values, $\mu_a = 0.0125, 0.025, 0.04,$ and 0.05 mm^{-1} ; (c) fluorescence and reference channel PMT readings (red crosses=reference, blue dots=fluorescence) for increasing concentrations of PpIX in a phantom; and (d) correlation of fluorescence channel signals to PpIX concentrations, after crosstalk adjustment. The detection precision was estimated to be $0.1 \mu\text{g/ml}$, and the linear range was up to $4 \mu\text{g/ml}$. (Color online only.)



(a)

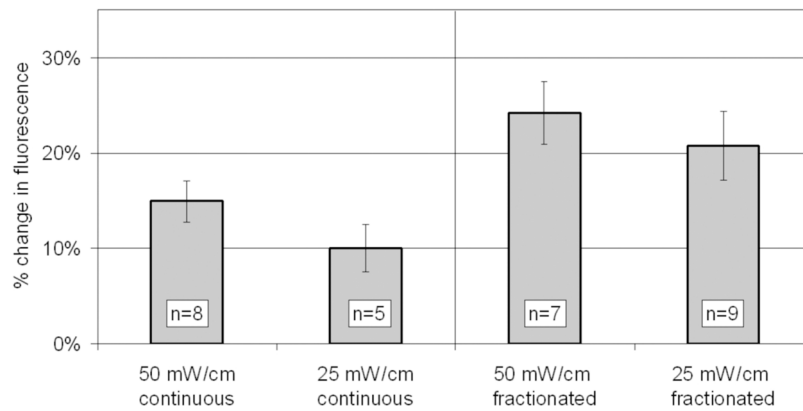

(b)

Fig. 4. (a) PpIX fluorescence as measured from rat esophagus under varying treatment conditions before and after PDT, with error bars showing the standard error in the groups, and (b) the calculated percentage change in the esophagus fluorescence.

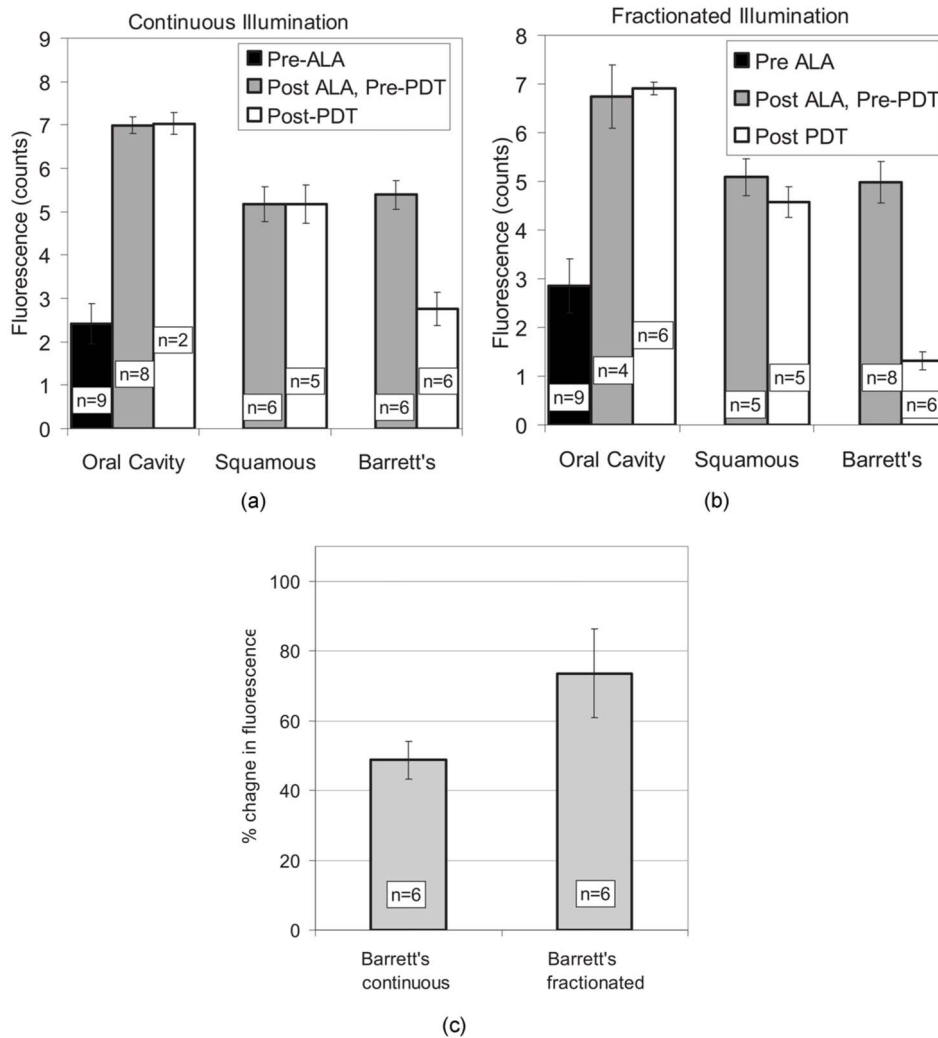
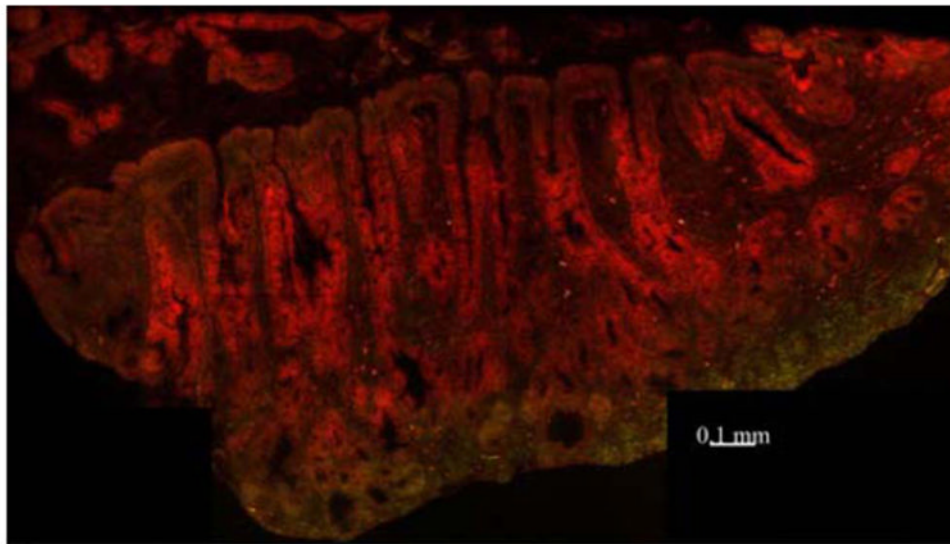
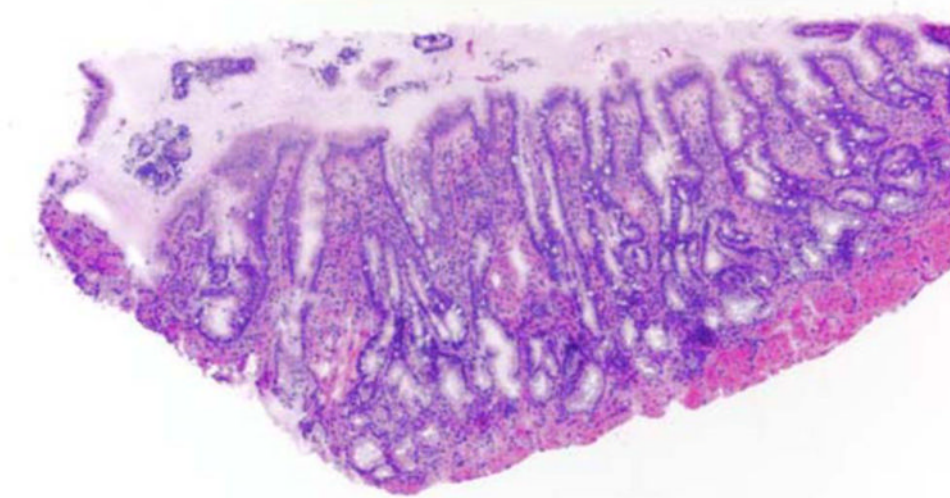

Fig. 5. PpIX fluorescence as measured from Barrett’s tissue and two nonilluminated control sites of oral cavity and normal squamous tissue, with standard error values in each group shown as error bars. (a) Data from continuous irradiation (b) and fractionated irradiation with 1-min on/off fractions. (c) Significant photobleaching was observed in the Barrett’s tissue for both continuous illumination ($P < 0.001$) and fractionated illumination ($P < 0.001$) with the 635-nm light (150 J/cm^2 at 150 mW/cm^2). The Barrett’s site treated with fractionated illumination photobleached significantly more than the site treated with continuous illumination following PDT ($P < 0.001$).



(a)



(b)

Fig. 6. PpIX fluorescence levels shown as measured from Barrett's tissue and two nonilluminated control sites of oral cavity and normal squamous tissue. Significant photobleaching was observed in the Barrett's tissue following either (a) continuous illumination (P value <0.001 , $n = 4$) or (b) fractionated illumination ($P < 0.001$, $n = 3$) with 635-nm light (150 J/cm^2 at 150 mW/cm^2). The Barrett's site treated with fractionated illumination photobleached significantly more than the site treated with continuous illumination following PDT (P value <0.001).