



Review

Cite this article: Witter MP, Canto CB, Couey JJ, Koganezawa N, O'Reilly KC. 2014 Architecture of spatial circuits in the hippocampal region. *Phil. Trans. R. Soc. B* **369**: 20120515.
<http://dx.doi.org/10.1098/rstb.2012.0515>

One contribution of 24 to a Theo Murphy Meeting Issue 'Space in the brain: cells, circuits, codes and cognition'.

Subject Areas:

neuroscience

Keywords:

entorhinal cortex, presubiculum, parasubiculum, hippocampus, development

Author for correspondence:

Menno P. Witter
e-mail: menno.witter@ntnu.no

Architecture of spatial circuits in the hippocampal region

Menno P. Witter¹, Cathrin B. Canto^{1,2}, Jonathan J. Couey^{1,3},
Noriko Koganezawa^{1,4} and Kally C. O'Reilly^{1,5}

¹Kavli Institute for Systems Neuroscience and Centre for Neural Computation, Norwegian University of Science and Technology, 7030 Trondheim, Norway

²Royal Academy for Arts and Sciences, Netherlands Institute for Neuroscience, 1105 BA Amsterdam, The Netherlands

³Department of Psychiatry, Erasmus Medical Center, Rotterdam, The Netherlands

⁴Department of Neurobiology and Behavior, Gunma University Graduate School of Medicine, 371-8511 Maebashi, Japan

⁵Center for Neural Science, New York University, 4 Washington Place, New York, NY 10003-6621, USA

The hippocampal region contains several principal neuron types, some of which show distinct spatial firing patterns. The region is also known for its diversity in neural circuits and many have attempted to causally relate network architecture within and between these unique circuits to functional outcome. Still, much is unknown about the mechanisms or network properties by which the functionally specific spatial firing profiles of neurons are generated, let alone how they are integrated into a coherently functioning meta-network. In this review, we explore the architecture of local networks and address how they may interact within the context of an overarching space circuit, aiming to provide directions for future successful explorations.

1. Introduction

The hippocampal–parahippocampal region contains a diversity of neural circuits and functionally specialized cell-types involved in the representation of self-location. Hippocampal networks, particularly those of CA3 and CA1, embed the place cells, encoding locations in specific environments. Parahippocampal networks in the medial entorhinal cortex (MEC) and the associated presubiculum (PrS) and parasubiculum (PaS) provide anchorage for grid cells, head-direction cells and border cells. The latter three functionally defined neuron types universally map directions and positions, irrespective of the environment. As yet, little is known about the mechanisms or network properties by which these functionally specific firing profiles are generated, let alone how they are integrated into a coherently functioning meta-network.

From the maiden exploratory voyages through the navigational system in the brain, the system appeared neatly organized, with individual functional cell-types belonging to unique neural networks. Place cells were described in the hippocampus [1], whereas head-direction neurons were associated with the dorsal PrS [2,3]. In MEC, grid cells were subsequently discovered as the third main component [4,5]. Similar to how sirens lured ship's navigators to their treacherous coast, these observations lured the field to the concept that each functional cell-type was associated with a certain network architecture and that there was likely a hierarchical relationship between these three functional cell-types. This induced attempts to model upstream or downstream relationships between these cell-types [6–10]. Subsequent studies showed that although grid cells are prominent in layer II of MEC, they co-localize, particularly in deeper layers III–VI, with head-direction cells and with yet another cell-type, the border or boundary vector cells. Neurons that showed combinations of some features were also described in MEC [5,11–13]. The same constellation of neuron types exists in PrS and PaS [11], casting doubts on whether functional cell-types could be related to specific neural architectures. An alternative interpretation is that the neural signals do reflect neural

computations of a specific neural architecture, and that emerging local signals are transferred to adjacent networks. Although this might provide a suitable and attractive explanation for the presence of for example border or boundary vector cells in subiculum, in MEC and in PrS and PaS [14], it does not explain why grid cells, head-direction cells and border cells are not present in the CA-fields, and vice versa, why the typical CA1 place cells with narrow fields are only sparsely present in the subiculum and any of the parahippocampal areas [15–18]. In this review, we explore our current knowledge about the architecture of local networks and how networks interact, providing possibilities for input interactions or interactions between inputs and local circuit operations [19–21].

2. Classical network

We focus on MEC as the core structure around which to centre the remaining (para)hippocampal structures. The by now accepted ‘classical’ network [22–24] is already more elaborate than that proposed at the time of the trisynaptic pathway [25]. Neurons in layers II and III of MEC give rise to projections to all constituents of the hippocampus. Layer II cells project to DG and CA3, whereas cells in layer III project to CA1 and the subiculum. The layer II projection to DG is the entry point of the trisynaptic pathway, which subsequently includes the mossy fibre projection from DG to CA3 and the Schaffer collateral projection from CA3 to CA1 (figure 1). The two entorhinal inputs have become known as the direct (layer III to CA1) and the indirect (layer II via the trisynaptic pathway) pathways to CA1. A substantial part of the inputs to MEC layers II and III originate from PrS and PaS [26]. Efferent MEC projections to cortical and subcortical domains originate mainly from layers V and VI, the recipients of hippocampal output from CA1 and the subiculum. Although the reciprocal entorhinal–CA1 network shows a complicated topographical organization, it has a high connective fidelity in that any point source in MEC that originates projections to CA1 will receive output from that recipient part of CA1 [27]. This reciprocal connectivity provides a clear hierarchical perspective in that grid cells in MEC are downstream to head-direction cells in pre- and parasubiculum, and upstream to place cells. The latter is true for both CA3 and CA1, because grid cells are present in both layers II and III of MEC. Model studies have shown that the sum of many grid cells with different orientations and spatial phases or the summation of border cells can result in place cell firing [8,9,19,20,28–30]. Place cell firing can be transformed into grid cell firing [31], potentially explaining the presence of grid cells in MEC layer V. Adding the projections from layer V neurons to superficial layers II and III [32,33] closes the loop between place cells in CA1 and grid cells in layers II and III (figures 1, 2 and 3).

3. Place cells and grid cells

The fact that place cells mature earlier than grid cells during postnatal development [35,36] defies the concept that place cells emerge from convergence of grid cell outputs onto a pyramidal cell, although disrupting the inputs from MEC layer III to CA1 lowers the specificity of place cell firing [37]. Even more challenging is fact that inputs from grid

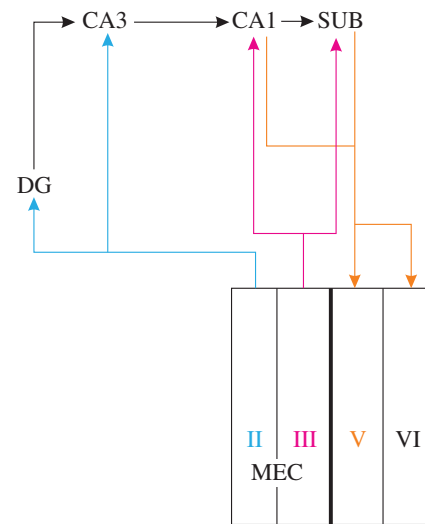

Figure 1. The ‘classical’ hippocampal–parahippocampal network. Neurons in MEC layer II provide inputs DG and CA3, feeding into the trisynaptic pathway that includes projections from DG to CA3 to CA1. Layer III neurons project to CA1 and SUB, which both reciprocate with projections to layer V (and weaker to VI). (Online version in colour.)

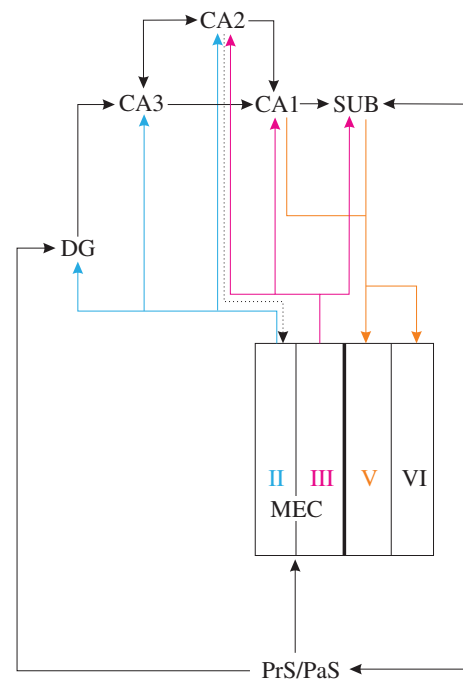

Figure 2. Extended hippocampal–parahippocampal network. The ‘classical’ scheme with added local connectivity of PrS and PaS and the reciprocal layer II–CA2 pathway. (Online version in colour.)

cells in MEC layer III, of which combined output result in CA1 place cells, likely project to pyramidal cells in the subiculum as well, yet resulting in very different spatial properties of subiculum neurons [15,16]. The difference between CA1 and subiculum neural firing, narrow place fields in CA1 and more broader ones with a higher background firing in subiculum, might result from two different network architectures. First, CA1 single pyramidal cells receive convergent input from MEC and CA3. However, removing the output from CA3 does not strongly effect place fields recorded in CA1 [38,39]. In the subiculum, such convergence between CA1 and MEC inputs is non-existent [40]. Second, neurons in the MEC recipient portion of the

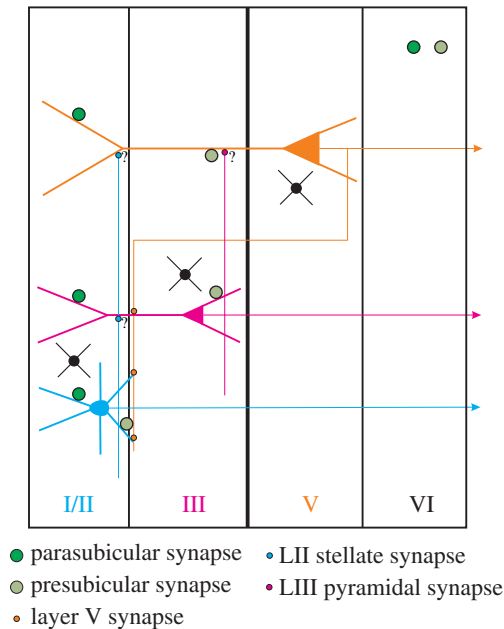

Figure 3. Medial entorhinal circuits. Principal cells in all layers receive monosynaptic convergent inputs from PrS and PaS. Axons of layer V pyramidal cells target superficial layers, making synaptic contacts onto principal cells in layers II and III. These layer V cells are likely contacted by local axons of layer II and III cells, and cells in layer II presumably contact layer III cells. Although no neurons are indicated in layer VI, synaptic contacts from PrS and PaS have been reported [34] and are schematically indicated. (Online version in colour.)

subiculum, the distal part that borders PrS, differ markedly in their electrophysiological properties from those in CA1 [41]. Particularly, the distal neurons may combine hippocampal spatial codes with contextual information into spatial-rich signal to be used by other brain regions [16].

4. Layer II medial entorhinal cortex network generates grid cell firing

Among the theoretical models for grid cells in layer II, one class, the attractor models, emphasizes the internal connectivity in MEC, assuming that between grid cells a precisely formed connectivity pattern exists that includes both excitatory and inhibitory connections [6,7,42]. The other class, the oscillatory interference models, postulates interactions between two independent oscillators to be responsible for grid cell properties. In the case of grid cells in layer II, the interference is between field theta oscillations or network oscillations, and cell-specific subthreshold membrane oscillations [43–45]. Both models converge on the basic assumption that grid cells emerge from certain local network features with the added presence of directional input. In two recent studies, the local network in layer II was scrutinized using an *in vitro* approach [46,47]. The focus was on stellate cells, which are the most likely candidates to be grid cells in layer II [48–50]. Both studies showed that stellate cells are exclusively interconnected via fast-spiking inhibitory interneurons. Model attractor networks demonstrated that stable grid firing can emerge from a simple recurrent inhibitory network, thus suggesting that the observed inhibitory microcircuitry between stellate cells is sufficient to generate grid-cell firing. The models rely on the presence of head-directional and velocity-tuned inputs in addition to an

excitatory input that exceeds the local inhibition. The two studies differ with respect to the type of excitatory input used in the model, constant [46] or oscillatory in the theta range [47]. There is experimental evidence that removing either type of input disrupts grid cell properties *in vivo* [51–53]. The excitatory input from the hippocampus is thought to reach the grid cells in layer II via an intermediary synapse in layer V, following the scheme outlined above (figure 3). A direct projection from CA2 to layer II of MEC has been suggested as a monosynaptic alternative (figure 2) [54], but this projection has not been confirmed by others [55]. Whether or not to welcome CA2 as a new player in the field of place-to-grid cell interactions remains thus to be seen, although the unique integrative responses of CA2 neurons make them likely key players in the grid-to-place cell interactions [56,57]. The required excitatory drive may also come from local excitatory networks in MEC, embedded in layer II through non-stellate cells or feedback loops between the layers [32,33,58,59]. Interestingly, a comparable local architecture with principal cells being connected almost exclusively through an inhibitory interneuron network that receives excitatory inputs is also found in DG [60,61]. The fact that grid cells have not been reported in DG thus points to head-directional and velocity-tuned inputs as relevant for grid cell firing to emerge.

It is well known that layer II of MEC not only contains stellate cells and fast-spiking interneurons, but also pyramidal cells and low threshold-spiking interneurons [46,62]. Our data indicated that reciprocal connectivity between fast-spiking interneurons and stellate cells was high, and stellate cell connectivity to fast-spiking interneurons was much higher than to low threshold-spiking interneurons. Stellate cells connect to pyramidal neurons, whereas the reverse connection was not found [46]. Among the fast-spiking neurons are parvalbumin-positive basket cells providing perisomatic inhibition onto stellate cells and pyramidal cells [63,64]. Further detailing this network ([65]; own unpublished observations, 2013), we postulate the presence of two, independently modulated networks. The first, made up by hippocampus-projecting, reelin-positive stellate cells and fast-spiking parvalbumin-positive interneurons, and a second, comprising non-hippocampal projecting pyramidal cells and parvalbumin-cholecystokinin (CCK)-positive interneurons (figure 4). The interactions between these two networks and the position of the low threshold-spiking interneurons remain to be established. It also remains to be seen whether the pyramidal cells in this second network do express grid-like firing. Although current *in vivo* recording data seem to indicate the opposite [48,49], pyramidal grid cells cannot be ruled out [46,48].

5. Grid cells in medial entorhinal cortex deep layers and in pre-parasubiculum

Grid cells are not unique for layer II of MEC; layers III, V and VI of MEC, as well as PrS and PaS, also contain grid cells together with stable percentages of head-direction, conjunctive and border cells [11–13]. The architecture in these layers and domains, although less well studied compared with layer II of MEC, is unlikely to be similar to the latter [63,66]. This raises the question whether grid cell properties in these networks are independently generated, as suggested above, through a local pyramidal cell network, or inherited

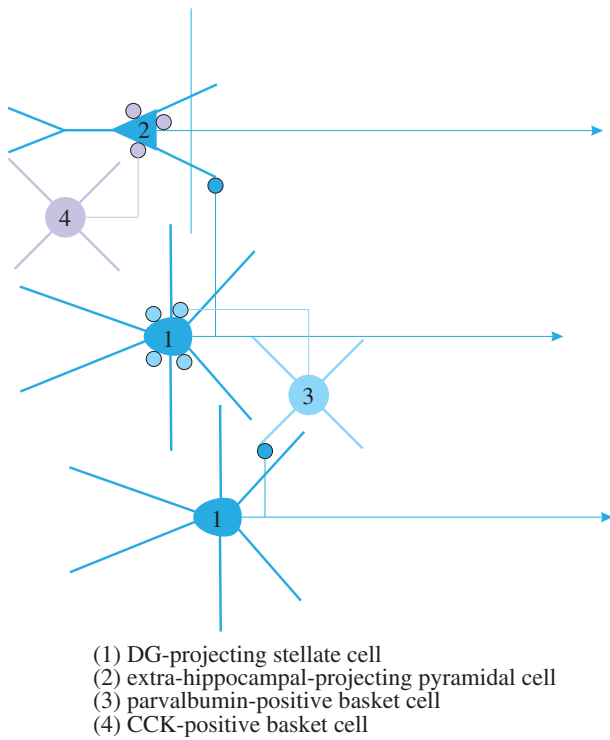

Figure 4. Proposed local circuits in medial entorhinal layer II. (1) DG projecting stellate cells make synaptic contacts with fast-spiking, (3) parvalbumin-positive interneurons that innervate the somata of stellate cells. Stellate-to-stellate synaptic contacts are non-existent. (2) Non-hippocampal projecting neurons, likely pyramidal cells receive input from stellate cells but do not reciprocate that input. The pyramidal cells are innervated by (4) CCK-positive basket cells. Other interneuron types, such as chandelier, goblet and multipolar cells, are not indicated. CCK, cholecystokinin. (Online version in colour.)

from MEC layer II. The latter scenario, in the case of MEC, requires an intrinsic network, connecting neurons in layer II to those in deeper layers. Although it is well established that neither axons of layer II stellate cells nor of pyramidal cells extensively target deep layers [59,62,67,68], superficial-to-deep connections do exist [69]. These are likely mediated by way of the apical dendrites of pyramidal cells in layers III and V (figure 3) [62,70]. Known connectivity does not make it plausible that the grid cells in PrS and PaS depend on inputs from MEC layer II. Projections from MEC to PrS and PaS are not dense and they mainly originate from layer V of MEC [71]. It thus seems likely that grid cells in PrS and PaS are locally generated.

6. Grid cells and head-direction cells

Directional information is apparently relevant for grid cell firing and is represented in all layers of MEC. Most models for grid cells in layer II of MEC postulated velocity-dependent directional information as relevant for the emergence of grid cell properties [6,7,44,46,47]. Supporting this postulate is the finding that layer II grid cells reveal directional tuning after removal of hippocampal inputs [51]. Grid cells in all layers show remarkably consistent orientations and directionally tuned neurons are present in layers III, V and VI [12]. Directional information is likely not generated within the network, because necessary inputs to MEC from the vestibular system, mediated by way of the lateral mammillary–anterior thalamic route [72–74],

are either sparse and restricted to the extreme dorsocaudal part [75,76], or absent [26]. Vestibular inputs however specifically influence PrS and PaS [77], which are known to give rise to about 35% of the hippocampal–parahippocampal input and around 15% of the total cortical inputs to MEC [26].

Projections from PrS and PaS show a strikingly laminar terminal distribution in superficial MEC [78,79]. Both inputs form synaptic contacts with principal neurons and interneurons that reside in the targeted layers [80–82]. In line with the above, proposed architecture mediating superficial to deep intrinsic connectivity in MEC, PrS and PaS inputs contact layer V pyramidal neurons on their apical dendrites [83]. We recently showed electrophysiologically that principal neurons in all layers of MEC receive convergent monosynaptic inputs from both PaS and PrS (figure 3) [34]. These shared inputs thus provide a parsimonious substrate for the prominent directional tuning of head-direction cells and the coherent orientational tuning of grid cells in all layers of MEC.

The postnatal timing of emergent head-directional and grid cell properties in the network may be indicative as well for the relevance of head-direction cells. *In vivo* recordings in freely behaving animals, from the moment after eye-opening (postnatal day (P) 14/15), when they start to actively leave the nest, showed that the latter are the first to be present. The percentage of head-direction cells as well as the degree of directional tuning were similar to that in adults, and the cells were stable between sessions [35,36]. Data obtained in brain slices with preserved connectivity between PaS, PrS and MEC showed that projections from PaS and PrS to MEC become functional around P9/P10 before grid cell firing is apparent in MEC. After P14/P15, the connectivity from PaS and PrS to MEC becomes more adult-like even though minor changes still occur from P15 to P30 [35,84].

Grid cell properties continue to develop from P16 until at least P34. Their periodic properties evolve between P16 and P34, reaching adult levels around the end of that period [35]. The gradually increasing precision of grid cells was found to be paralleled with developmental changes in the local layer II network [35,46]. There was a notable increase in the synchrony of spontaneous subthreshold changes in membrane potentials of stellate cells from P16 to P29. These membrane potential changes are considered a hallmark feature of MEC layer II stellate cells and have been implicated in the oscillatory interference models as one of the two oscillators needed for the formation of grid cells [44,85,86]. All data thus suggest that head-directional representations are established and reach MEC before grid-like firing properties emerge. These inputs are fine-tuned during the subsequent two weeks, in parallel to a further development of the intrinsic connectivity of the layer II network.

7. Concluding remarks

Networks in divisions of the hippocampal region provide the substrate for many complex integrative processes, resulting from local and more complex, higher-order interactions. The focus on either these local interactions or the more complex, partially hierarchical processes has contributed to a mechanistic description of the functionally different spatially modulated cells. Now, it is time to move forward to abandon the classic hierarchical view and to encompass the many parallel and converging routes present in the region and the

importance of feedback and feed-forward balance. A similar shift in emphasis in visual research away from a pure hierarchical conceptualization has led to the notion that feedback from downstream and lateral processing systems contribute to a sharpened upstream processing [87]. The balance between feed-forward and feedback processing in the visual system partially depends on differential distributions of various glutamate receptors [88]. In a parallel manner, a differential

distribution of NMDA receptors onto two different types of MEC layer II interneurons has been proposed to result in the switching between slow and fast gamma oscillations [89]. Adding this level of detail to network descriptions is one of the future challenges.

Funding statement. The preparation of this manuscript was supported by the Kavli Foundation and a Centre of Excellence grant from the Norwegian Research Council.

References

- O'Keefe J, Dostrovsky J. 1971 The hippocampus as a spatial map. Preliminary evidence from unit activity in the freely-moving rat. *Brain Res.* **34**, 171–175. (doi:10.1016/0006-8993(71)90358-1)
- Ranck JB. 1985 Head direction cells in the deep cell layer of dorsal presubiculum in freely moving rats. In *Electrical activity of the archicortex* (eds G Buzsáki, CH Vanderwolf), pp. 217–220. Budapest, Hungary: Akademiai Kiado.
- Taupe JS, Muller RU, Ranck Jr JB. 1990 Head-direction cells recorded from the postsubiculum in freely moving rats. I. Description and quantitative analysis. *J. Neurosci.* **10**, 420–435.
- Fyhn M *et al.* 2004 Spatial representation in the entorhinal cortex. *Science* **305**, 1258–1264. (doi:10.1126/science.1099901)
- Hafting T, Fyhn M, Molden S, Moser M-B, Moser EI. 2005 Microstructure of a spatial map in the entorhinal cortex. *Nature* **436**, 801–806. (doi:10.1038/nature03721)
- Fuhs MC, Touretzky DS. 2006 A spin glass model of path integration in rat medial entorhinal cortex. *J. Neurosci.* **26**, 4266–4276. (doi:10.1523/JNEUROSCI.4353-05.2006)
- McNaughton BL, Battaglia FP, Jensen O, Moser EI, Moser M-B. 2006 Path integration and the neural basis of the 'cognitive map'. *Nat. Rev. Neurosci.* **7**, 663–678. (doi:10.1038/nrn1932)
- Solstad T, Moser EI, Eivvoll GT. 2006 From grid cells to place cells: a mathematical model. *Hippocampus* **16**, 1026–1031. (doi:10.1002/hipo.20244)
- O'Keefe J, Burgess N. 2005 Dual phase and rate coding in hippocampal place cells: theoretical significance and relationship to entorhinal grid cells. *Hippocampus* **15**, 853–866. (doi:10.1002/hipo.20115)
- Molter C, Yamaguchi Y. 2008 Entorhinal theta phase precession sculpts dentate gyrus place fields. *Hippocampus* **18**, 919–930. (doi:10.1002/hipo.20450)
- Boccaro CN, Sargolini F, Thoresen VH, Solstad T, Witter MP, Moser EI, Moser M-B. 2010 Grid cells in pre- and parasubiculum. *Nat. Neurosci.* **13**, 987–994. (doi:10.1038/nn.2602)
- Sargolini F *et al.* 2006 Conjunctive representation of position, direction, and velocity in entorhinal cortex. *Science* **312**, 758–762. (doi:10.1126/science.1125572)
- Solstad T, Boccaro CN, Kropff E, Moser M-B, Moser EI. 2008 Representation of geometric borders in the entorhinal cortex. *Science* **322**, 1865–1868. (doi:10.1126/science.1166466)
- Lever C, Burton S, Jewejee A, O'Keefe J, Burgess N. 2009 Boundary vector cells in the subiculum of the hippocampal formation. *J. Neurosci.* **29**, 9771–9777. (doi:10.1523/JNEUROSCI.1319-09.2009)
- Sharp PE, Green C. 1994 Spatial correlates of firing patterns of single cells in the subiculum of the freely moving rat. *J. Neurosci.* **14**, 2339–2356.
- Kim SM, Ganguli S, Frank LM. 2012 Spatial information outflow from the hippocampal circuit: distributed spatial coding and phase precession in the subiculum. *J. Neurosci.* **32**, 11 539–11 558. (doi:10.1523/JNEUROSCI.5942-11.2012)
- Hargreaves EL *et al.* 2005 Major dissociation between medial and lateral entorhinal input to dorsal hippocampus. *Science* **308**, 1792–1794. (doi:10.1126/science.1110449)
- Taupe JS. 1995 Place cells recorded in the parasubiculum of freely moving rats. *Hippocampus* **5**, 569–583. (doi:10.1002/hipo.450050608)
- Rolls ET, Stringer SM, Elliot T. 2006 Entorhinal cortex grid cells can map to hippocampal place cells by competitive learning. *Network* **17**, 447–465. (doi:10.1080/09548980601064846)
- Savelli F, Knierim JJ. 2010 Hebbian analysis of the transformation of medial entorhinal grid-cell inputs to hippocampal place fields. *J. Neurophysiol.* **103**, 3167–3183. (doi:10.1152/jn.00932.2009)
- Lee D, Lin BJ, Lee AK. 2012 Hippocampal place fields emerge upon single-cell manipulation of excitability during behavior. *Science* **337**, 849–853. (doi:10.1126/science.1221489)
- van Strien NM, Cappaert NL, Witter MP. 2009 The anatomy of memory: an interactive overview of the parahippocampal–hippocampal network. *Nat. Rev. Neurosci.* **10**, 272–282. (doi:10.1038/nrn2614)
- Somogyi P. 2010 Hippocampus: intrinsic organization. In *Handbook of brain microcircuits* (eds GM Shepherd, S Grillner), pp. 148–164. Oxford, UK: Oxford University Press.
- Witter MP. 2011 Connectivity of the Hippocampus. In *Hippocampal microcircuits* (ed. VEA Cutsuridis), pp. 5–26. Springer series in Computational Neuroscience. Berlin, Germany: Springer.
- Andersen P, Bliss TV, Skrede KK. 1971 Unit analysis of hippocampal population spikes. *Exp. Brain Res.* **13**, 208–221. (doi:10.1007/BF00234086)
- Kerr KM, Agster KL, Furtak SC, Burwell RD. 2007 Functional neuroanatomy of the parahippocampal region: the lateral and medial entorhinal areas. *Hippocampus* **17**, 697–708. (doi:10.1002/hipo.20315)
- Naber PA, Lopes Da Silva FH, Witter MP. 2001 Reciprocal connections between the entorhinal cortex and hippocampal fields CA1 and the subiculum are in register with the projections from CA1 to the subiculum. *Hippocampus* **11**, 99–104. (doi:10.1002/hipo.1028)
- de Almeida I, Idiart M, Lisman JE. 2009 The input–output transformation of the hippocampal granule cells: from grid cells to place fields. *J. Neurosci.* **29**, 7504–7512. (doi:10.1523/JNEUROSCI.6048-08.2009)
- O'Keefe J, Burgess N. 1996 Geometric determinants of the place fields of hippocampal neurons. *Nature* **381**, 425–428. (doi:10.1038/381425a0)
- Barry C *et al.* 2006 The boundary vector cell model of place cell firing and spatial memory. *Rev. Neurosci.* **17**, 71–97. (doi:10.1515/REVNEURO.2006.17.1-2.71)
- Kropff E, Treves A. 2008 The emergence of grid cells: intelligent design or just adaptation? *Hippocampus* **18**, 1256–1269. (doi:10.1002/hipo.20520)
- Kloosterman F, van Haften T, Witter MP, Lopes da Silva FH. 2003 Electrophysiological characterization of interlaminar entorhinal connections: an essential link for re-entrance in the hippocampal–entorhinal system. *Eur. J. Neurosci.* **18**, 3037–3052. (doi:10.1111/j.1460-9568.2003.03046.x)
- Van Haften T, Baks-te-Bulte L, Goede PH, Wouterlood FG, Witter MP. 2003 Morphological and numerical analysis of synaptic interactions between neurons in deep and superficial layers of the entorhinal cortex of the rat. *Hippocampus* **13**, 943–952. (doi:10.1002/hipo.10144)
- Canto CB, Koganezawa N, Beed P, Moser EI, Witter MP. 2012 All layers of medial entorhinal cortex receive presubicular and parasubicular inputs. *J. Neurosci.* **32**, 17 620–17 631. (doi:10.1523/JNEUROSCI.3526-12.2012)
- Langston RF, Ainge JA, Couey JJ, Canto CB, Bjerknes TL, Witter MP, Moser EI, Moser M-B. 2010 Development of the spatial representation system in the rat. *Science* **328**, 1576–1580. (doi:10.1126/science.1188210)
- Wills TJ, Cacucci F, Burgess N, O'Keefe J. 2010 Development of the hippocampal cognitive map in preweaning rats. *Science* **328**, 1573–1576. (doi:10.1126/science.1188224)

37. Brun VH, Leutgeb S, Wu H-Q, Schwarz R, Witter MP, Moser EI, Moser M-B. 2008 Impaired spatial representation in CA1 after lesion of direct input from entorhinal cortex. *Neuron* **57**, 290–302. (doi:10.1016/j.neuron.2007.11.034)
38. Brun VH *et al.* 2002 Place cells and place recognition maintained by direct entorhinal–hippocampal circuitry. *Science* **296**, 2243–2246. (doi:10.1126/science.1071089)
39. Nakashiba T, Young JZ, McHugh TJ, Buhl DL, Tonegawa S. 2008 Transgenic inhibition of synaptic transmission reveals role of CA3 output in hippocampal learning. *Science* **319**, 1260–1264. (doi:10.1126/science.1151120)
40. Cappaert NL, Wadman WJ, Witter MP. 2007 Spatiotemporal analyses of interactions between entorhinal and CA1 projections to the subiculum in rat brain slices. *Hippocampus* **17**, 909–921. (doi:10.1002/hipo.20309)
41. Graves AR, Moore SJ, Bloss EB, Mensh BD, Kath WL, Spruston N. 2012 Hippocampal pyramidal neurons comprise two distinct cell types that are countermodulated by metabotropic receptors. *Neuron* **76**, 776–789. (doi:10.1016/j.neuron.2012.09.036)
42. Burak Y, Fiete IR. 2009 Accurate path integration in continuous attractor network models of grid cells. *PLoS Comput. Biol.* **5**, e1000291. (doi:10.1371/journal.pcbi.1000291)
43. Welday AC, Shlifer IG, Bloom ML, Zhang K, Blair HT. 2011 Cosine directional tuning of theta cell burst frequencies: evidence for spatial coding by oscillatory interference. *J. Neurosci.* **31**, 16 157–16 176. (doi:10.1523/JNEUROSCI.0712-11.2011)
44. Burgess N, Barry C, O'Keefe J. 2007 An oscillatory interference model of grid cell firing. *Hippocampus* **17**, 801–812. (doi:10.1002/hipo.20327)
45. Zilli EA, Hasselmo ME. 2010 Coupled noisy spiking neurons as velocity-controlled oscillators in a model of grid cell spatial firing. *J. Neurosci.* **30**, 13 850–13 860. (doi:10.1523/JNEUROSCI.0547-10.2010)
46. Couey JJ *et al.* 2013 Recurrent inhibitory circuitry as a mechanism for grid formation. *Nat. Neurosci.* **16**, 318–324. (doi:10.1038/nn.3310)
47. Pastoll H, Solanka L, van Rossum MCW, Nolan MF. 2013 Feedback inhibition enables theta-nested gamma oscillations and grid firing fields. *Neuron* **77**, 141–154. (doi:10.1016/j.neuron.2012.11.032)
48. Domnisoru C, Kinkhabwala AA, Tank DW. 2013 Membrane potential dynamics of grid cells. *Nature* **495**, 199–204. (doi:10.1038/nature11973)
49. Burgalossi A, Herfst L, von Heimendahl M, Haskic K, Schmidt M, Brecht M. 2011 Microcircuits of functionally identified neurons in the rat medial entorhinal cortex. *Neuron* **70**, 773–786. (doi:10.1016/j.neuron.2011.04.003)
50. Schmidt-Hieber C, Hausser M. 2013 Cellular mechanisms of spatial navigation in the medial entorhinal cortex. *Nat. Neurosci.* **16**, 325–331. (doi:10.1038/nn.3340)
51. Bonnevie T *et al.* 2013 Grid cells require excitatory drive from the hippocampus. *Nat. Neurosci.* **16**, 309–317. (doi:10.1038/nn.3311)
52. Brandon MP, Bogaard R, Libby CP, Connerney MA, Gupta K, Hasselmo ME. 2011 Reduction of theta rhythm dissociates grid cell spatial periodicity from directional tuning. *Science* **332**, 595–599. (doi:10.1126/science.1201652)
53. Koenig J, Linder AN, Leutgeb JK, Leutgeb S. 2011 The spatial periodicity of grid cells is not sustained during reduced theta oscillations. *Science* **332**, 592–595. (doi:10.1126/science.1201685)
54. Rowland DC *et al.* 2013 Transgenically targeted rabies virus demonstrates a major monosynaptic projection from hippocampal area CA2 to medial entorhinal layer II neurons. *J. Neurosci.* **33**, 14 889–14 898. (doi:10.1523/JNEUROSCI.1046-13.2013)
55. Cui Z, Gerfen CR, Young 3rd WS. 2012 Hypothalamic and other connections with the dorsal CA2 area of the mouse hippocampus. *J. Comp. Neurol.* **521**, 1844–1866. (doi:10.1002/cne.23263)
56. Chevaleyre V, Siegelbaum SA. 2010 Strong CA2 pyramidal neuron synapses define a powerful disinhibitory cortico-hippocampal loop. *Neuron* **66**, 560–572. (doi:10.1016/j.neuron.2010.04.013)
57. Jones MW, McHugh TJ. 2011 Updating hippocampal representations: CA2 joins the circuit. *Trends Neurosci.* **34**, 526–535. (doi:10.1016/j.tins.2011.07.007)
58. Beed P, Bendels MHK, Wiegand HF, Leibold C, Jochenning FW, Schmitz D. 2010 Analysis of excitatory microcircuitry in the medial entorhinal cortex reveals cell-type-specific differences. *Neuron* **68**, 1059–1066. (doi:10.1016/j.neuron.2010.12.009)
59. Quilichini P, Sirota A, Buzsaki G. 2010 Intrinsic circuit organization and theta-gamma oscillation dynamics in the entorhinal cortex of the rat. *J. Neurosci.* **30**, 11 128–11 142. (doi:10.1523/JNEUROSCI.1327-10.2010)
60. Morgan RJ, Santhakumar V, Soltesz I. 2007 Modeling the dentate gyrus. *Prog. Brain Res.* **163**, 639–658. (doi:10.1016/S0079-6123(07)63035-0)
61. Acsady L *et al.* 1998 GABAergic cells are the major postsynaptic targets of mossy fibers in the rat hippocampus. *J. Neurosci.* **18**, 3386–3403.
62. Canto CB, Witter MP. 2012 Cellular properties of principal neurons in the rat entorhinal cortex. II. The medial entorhinal cortex. *Hippocampus* **22**, 1277–1299. (doi:10.1002/hipo.20993)
63. Canto CB, Wouterlood FG, Witter MP. 2008 What does the anatomical organization of the entorhinal cortex tell us? *Neural Plast.* **2008**, 381243. (doi:10.1155/2008/381243)
64. Jones RS, Buhl EH. 1993 Basket-like interneurons in layer II of the entorhinal cortex exhibit a powerful NMDA-mediated synaptic excitation. *Neurosci. Lett.* **149**, 35–39. (doi:10.1016/0304-3940(93)90341-H)
65. Varga C, Lee SY, Soltesz I. 2010 Target-selective GABAergic control of entorhinal cortex output. *Nat. Neurosci.* **13**, 822–824. (doi:10.1038/nn.2570)
66. Dhillon A, Jones RS. 2000 Laminar differences in recurrent excitatory transmission in the rat entorhinal cortex *in vitro*. *Neuroscience* **99**, 413–422. (doi:10.1016/S0306-4522(00)00225-6)
67. Jones RS. 1994 Synaptic and intrinsic properties of neurons of origin of the perforant path in layer II of the rat entorhinal cortex *in vitro*. *Hippocampus* **4**, 335–353. (doi:10.1002/hipo.450040317)
68. Klink R, Alonso A. 1997 Morphological characteristics of layer II projection neurons in the rat medial entorhinal cortex. *Hippocampus* **7**, 571–583. (doi:10.1002/(SICI)1098-1063(1997)7:5<571::AID-HIPO12>>3.0.CO;2-Y)
69. Iijima T, Witter MP, Ichikawa M, Tominaga T, Kajiwara R, Matsumoto G. 1996 Entorhinal–hippocampal interactions revealed by real-time imaging. *Science* **272**, 1176–1179. (doi:10.1126/science.272.5265.1176)
70. Hamam BN *et al.* 2000 Morphological and electrophysiological characteristics of layer V neurons of the rat medial entorhinal cortex. *J. Comp. Neurol.* **418**, 457–472. (doi:10.1002/(SICI)1096-9861(20000320)418:4<457::AID-CNE7>>3.0.CO;2-L)
71. Kohler C. 1986 Intrinsic connections of the retrohippocampal region in the rat brain. II. The medial entorhinal area. *J. Comp. Neurol.* **246**, 149–169. (doi:10.1002/cne.902460202)
72. Taube JS. 1995 Head direction cells recorded in the anterior thalamic nuclei of freely moving rats. *J. Neurosci.* **15**, 70–86.
73. Stackman RW, Taube JS. 1998 Firing properties of rat lateral mammillary single units: head direction, head pitch, and angular head velocity. *J. Neurosci.* **18**, 9020–9037.
74. Vann SD. 2010 Re-evaluating the role of the mammillary bodies in memory. *Neuropsychologia* **48**, 2316–2327. (doi:10.1016/j.neuropsychologia.2009.10.019)
75. Shibata H. 1993 Direct projections from the anterior thalamic nuclei to the retrohippocampal region in the rat. *J. Comp. Neurol.* **337**, 431–445. (doi:10.1002/cne.903370307)
76. Van Groen T, Wyss JM. 1995 Projections from the anterodorsal and anteroventral nucleus of the thalamus to the limbic cortex in the rat. *J. Comp. Neurol.* **358**, 584–604. (doi:10.1002/cne.903580411)
77. Taube JS. 2007 The head direction signal: origins and sensory-motor integration. *Annu. Rev. Neurosci.* **30**, 181–207. (doi:10.1146/annurev.neuro.29.051605.112854)
78. Kohler C. 1985 Intrinsic projections of the retrohippocampal region in the rat brain. I. The subicular complex. *J. Comp. Neurol.* **236**, 504–522. (doi:10.1002/cne.902360407)
79. Caballero-Bleda M, Witter MP. 1993 Regional and laminar organization of projections from the presubiculum and parasubiculum to the entorhinal cortex: an anterograde tracing study in the rat. *J. Comp. Neurol.* **328**, 115–129. (doi:10.1002/cne.903280109)
80. Caballero-Bleda M, Witter MP. 1994 Projections from the presubiculum and the parasubiculum to morphologically characterized entorhinal–

- hippocampal projection neurons in the rat. *Exp. Brain Res.* **101**, 93–108. (doi:10.1007/BF00243220)
81. Van Haeften T *et al.* 1997 GABAergic presubicular projections to the medial entorhinal cortex of the rat. *J. Neurosci.* **17**, 862–874.
 82. Tolner EA, Frahm C, Metzger R, Gorter JA, Witte OW, Lopes da Silva FH, Heinemann U. 2007 Synaptic responses in superficial layers of medial entorhinal cortex from rats with kainate-induced epilepsy. *Neurobiol. Dis.* **26**, 419–438. (doi:10.1016/j.nbd.2007.01.009)
 83. Wouterlood FG, van Haeften T, Eijkhoudt M, Baks-te-Bulte L, Goede PH, Witter MP. 2004 Input from the presubiculum to dendrites of layer-V neurons of the medial entorhinal cortex of the rat. *Brain Res.* **1013**, 1–12. (doi:10.1016/j.brainres.2004.03.017)
 84. Koganezawa N, Canto CB, Witter MP. 2010 Postnatal development of functional connectivity from pre- and parasubiculum to medial entorhinal cortex. FENS abstr., p. 087.30.
 85. Giocomo LM, Zilli EA, Fransen E, Hasselmo ME. 2007 Temporal frequency of subthreshold oscillations scales with entorhinal grid cell field spacing. *Science* **315**, 1719–1722. (doi:10.1126/science.1139207)
 86. Hasselmo ME, Giocomo LM, Zilli EA. 2007 Grid cell firing may arise from interference of theta frequency membrane potential oscillations in single neurons. *Hippocampus* **17**, 1252–1271. (doi:10.1002/hipo.20374)
 87. Gilbert CD, Sigman M. 2007 Brain states: top-down influences in sensory processing. *Neuron* **54**, 677–696. (doi:10.1016/j.neuron.2007.05.019)
 88. Self MW, Kooijmans RN, Super H, Lamme VA, Roelfsema PR. 2012 Different glutamate receptors convey feedforward and recurrent processing in macaque V1. *Proc. Natl Acad. Sci. USA* **109**, 11 031–11 036. (doi:10.1073/pnas.1119527109)
 89. Middleton S, Jalics J, Kispersky T, LeBeau FEN, Roopun AK, Kopell NJ, Whittington MA, Cunningham MO. 2008 NMDA receptor-dependent switching between different gamma rhythm-generating microcircuits in entorhinal cortex. *Proc. Natl Acad. Sci. USA* **105**, 18 572–18 577. (doi:10.1073/pnas.0809302105)