

# A yeast artificial chromosome-based map of the region of chromosome 20 containing the diabetes-susceptibility gene, *MODY1*, and a myeloid leukemia related gene

(diabetes mellitus/leukemia/genetics/chromosome 20)

MARKUS STOFFEL\*†‡§, MICHELLE M. LE BEAU†, RAFAEL ESPINOSA III†, STEFAN F. BOHLANDER†, DENIS LE PASLIER¶, DANIEL COHEN¶, KUN-SAN XIANG\*†, NANCY J. COX†, STEFAN S. FAJANS||, AND GRAEME I. BELL\*†\*\*

\*Howard Hughes Medical Institute and Departments of †Medicine and \*\*Biochemistry and Molecular Biology, The University of Chicago, Chicago, IL 60637; ‡Laboratory of Metabolic Diseases, Rockefeller University, New York, NY 10021; ¶Fondation Jean Dausset-Centre d'Étude du Polymorphisme Humain, 75010 Paris, France; and ||Department of Internal Medicine, University of Michigan, Ann Arbor, MI 48109

Communicated by Alexander G. Bearn, The Rockefeller University, New York, NY, December 26, 1995 (received for review October 23, 1995)

**ABSTRACT** We have generated a physical map of human chromosome bands 20q11.2–20q13.1, a region containing a gene involved in the development of one form of early-onset, non-insulin-dependent diabetes mellitus, *MODY1*, as well as a putative myeloid tumor suppressor gene. The yeast artificial chromosome contig consists of 71 clones onto which 71 markers, including 20 genes, 5 expressed sequence tags, 32 simple tandem repeat DNA polymorphisms, and 14 sequence-tagged sites have been ordered. This region spans about 18 Mb, which represents about 40% of the physical length of 20q. Using this physical map, we have refined the location of *MODY1* to a 13-centimorgan interval ( $\approx 7$  Mb) between *D20S169* and *D20S176*. The myeloid tumor suppressor gene was localized to an 18-centimorgan interval ( $\approx 13$  Mb) between *RPN2* and *D20S17*. This physical map will facilitate the isolation of *MODY1* and the myeloid tumor suppressor gene.

Non-insulin-dependent diabetes mellitus (NIDDM) is a heterogeneous disorder characterized by impaired glucose-stimulated insulin release and reduced ability of insulin to stimulate glucose uptake by muscle and adipose tissue and suppress hepatic glucose production (1). Genetic factors play an important role in the development of this disorder, and one of the genes responsible for maturity-onset diabetes of the young (*MODY*), a form of NIDDM with onset in the first and second decades of life and autosomal dominant inheritance, is tightly linked to markers in the region of the adenosine deaminase gene (*ADA*) on chromosome 20 (2, 3). This diabetes-susceptibility gene, *MODY1*, has been localized to an approximately 13 centimorgan (cM) region of chromosome 20 in bands q11.2–q13.1 (4), a region which overlaps with a segment of the long arm of chromosome 20 deleted in some patients with malignant myeloid disorders and containing a putative tumor suppressor gene (5). The q11.2–q13.1 region of chromosome 20 may also include the genes responsible for several other disorders including posterior polymorphous corneal dystrophy, Holt–Oram syndrome, one form of Fanconi anemia, and benign neonatal epilepsy (6).

As a first step in isolating the genes responsible for these and other disorders, we have assembled a contig of yeast artificial chromosome (YAC) clones that spans a region of approximately 18 Mb and represents about 40% of the long arm of chromosome 20.

## MATERIALS AND METHODS

**YACs.** The YAC libraries were from the Centre d'Étude du Polymorphisme Humain (CEPH) and were screened using PCR and specific oligonucleotide primers. PCR was carried out in a 30- $\mu$ l volume containing 10 ng of pooled YAC DNA (CEPH 'A' and 'B' YAC DNA pools, Research Genetics, Huntsville, AL), 100  $\mu$ M of each primer, 400  $\mu$ M dNTP, 10 mM Tris-HCl (pH 8.3), 50 mM KCl, 1.5 mM MgCl<sub>2</sub>, and 2.5 units of *Taq* polymerase in a GeneAmp PCR System 9600 (Perkin-Elmer) for 35 cycles of denaturation at 94°C for 1 min, annealing for 1 min at a temperature 5–7°C below the melting temperature ( $t_m$ ) of the primer, and elongation at 72°C for 90 s. PCR products were separated by electrophoresis on 2% agarose gels and visualized by ethidium bromide staining.

**Chromosomal Microdissection and Alu PCR.** Chromosomal microdissection and Alu PCR were used to generate new and linking sequence-tagged sites (STSs). Bands 20q11.2–20q13.2 were microdissected from 15 trypsin-Giemsa-banded chromosome 20 homologs, amplified by sequence independent amplification (7), cloned into pGEM-3Z, and sequenced. Inter-Alu and vector-Alu PCR were carried out using the A33 primer, 5'-CACTGCACTCCAGCCTGGGCGAC-3' as described by Chumakov *et al.* (8). The Alu PCR products were cloned into pGEM-3Z and sequenced, and the sequence was used to generate a new STS.

**Pulsed-Field Gel Electrophoresis (PFGE).** High molecular weight YAC DNA was prepared in low melting point agarose plugs. YACs were separated from the other yeast chromosomes in 1% PFGE agarose in 0.5 $\times$  TBE (1 $\times$  TBE = 89 mM Tris base/89 mM boric acid/2 mM EDTA) at 14°C using the CHEF MAPPER (Bio-Rad). Electrophoresis conditions were a 120 angle, 6 V/cm voltage gradient, 60-s pulse time for the first 15 hr, and 60-s pulse time for the next 22 hr. Following electrophoresis, gels were stained with ethidium bromide, depurinated in 0.2 N HCl for 20 min, denatured and neutralized for 30 min and transferred to a nitrocellulose membrane in 20 $\times$  SSC (1 $\times$  SSC = 150 mM NaCl/15 mM sodium citrate, pH 7.0). The filters were hybridized to <sup>32</sup>P-labeled total human DNA to localize the YAC.

**Fluorescence *in Situ* Hybridization (FISH).** FISH was performed as described (9) using YAC DNA labeled by sequence independent amplification with Bio-11-dUTP (Enzo Diagnos-

Abbreviations: NIDDM, non-insulin-dependent diabetes mellitus; *MODY*, maturity-onset diabetes of the young; STS, sequence-tagged site; EST, expressed sequence tag; FISH, fluorescence *in situ* hybridization; PFGE, pulsed-field gel electrophoresis; STRP, simple tandem repeat DNA polymorphism; YAC, yeast artificial chromosome; cM, centimorgan.

§To whom reprint requests should be addressed at: Laboratory of Metabolic Diseases, Rockefeller University, New York, NY 10021.

The publication costs of this article were defrayed in part by page charge payment. This article must therefore be hereby marked "advertisement" in accordance with 18 U.S.C. §1734 solely to indicate this fact.

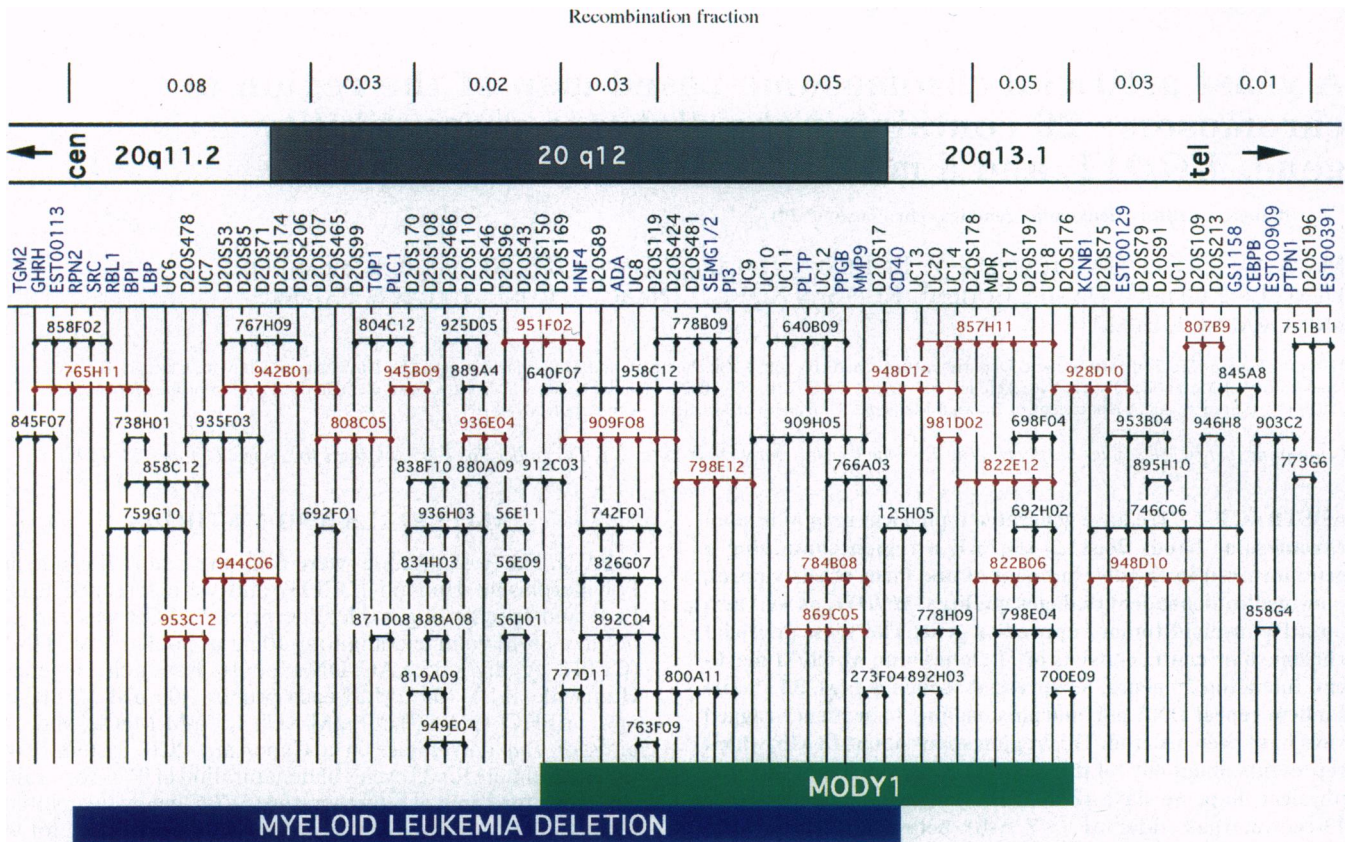

FIG. 1. STS content map of human chromosome bands 20q11.2-20q13.1. Expressed sequence tags (ESTs) are shown in blue, anonymous (STSs) are shown in black. YACs are shown as lines, the length of which reflects the number of included STSs, and not actual size. YACs shown in red were used for FISH to determine their cytogenetic location and degree of chimerism. The physical distances between adjacent STSs have not been determined directly. Diamonds indicate that the YAC was positive for the indicated STS. The relevant portion of 20q is shown above the contig with the genetic distances in cM between selected markers indicated. Only YACs that were found positive with more than one STS are shown. The regions containing *MODY1* and deleted in myeloid leukemia are indicated. The sequences of the STSs have been deposited in the GenBank database.

tics). Hybridization was detected with fluorescein-conjugated avidin (Vector Laboratories), and chromosomes were identified by staining with 4',6-diamidino-2-phenylindole dihydrochloride (DAPI). The probes for ordering *RPN2*, *SRC*, and *RBL1* by dual-color FISH were  $\lambda$ hRPII, cos1B, and  $\lambda$ p107-13A, with insert sizes of 15, 40, and 18 kb, respectively.

**Family with Early-Onset NIDDM.** The RW family, which includes >360 individuals from 5 generations and 72 members with diabetes including those with *MODY*, has been studied prospectively for 36 years (2). *MODY* subjects in this pedigree have varying degrees of hyperglycemia;  $\approx 80\%$  have or develop fasting hyperglycemia and  $\approx 30\%$  require insulin (2). Linkage

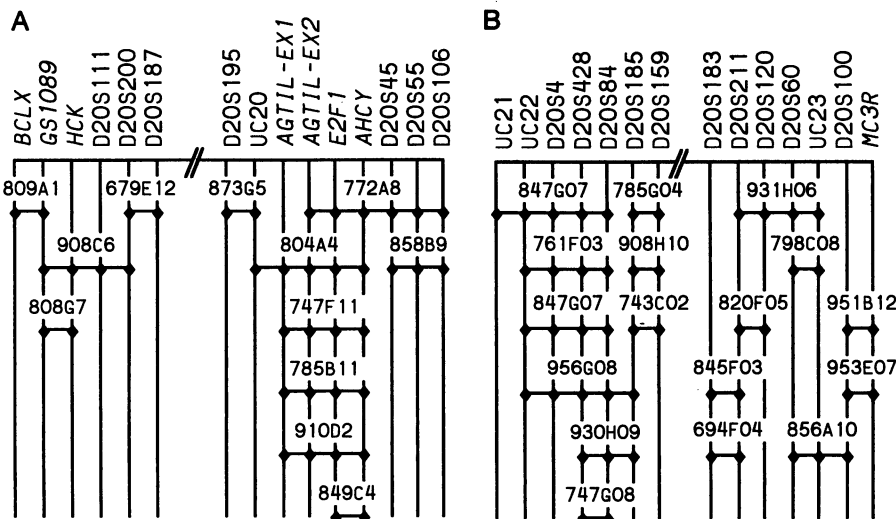

FIG. 2. STS content maps of human chromosome 20q proximal (centromeric) (A) and distal (telomeric) (B) to *TGM2* and *EST391*, respectively. EST and gene symbols are shown in italics.



studies have shown that the gene responsible for MODY in the RW family is the MODY1 locus in the region of the adenosine deaminase gene (3, 4).

**Genotyping.** Genotyping was carried out by PCR using specific oligonucleotide primers as described (10).

## RESULTS

**Construction of a YAC Contig by STS Analysis.** A YAC contig containing *MODY1* and the minimal deletion region associated with malignant myeloid disorders (Fig. 1) was generated using the CEPH YAC libraries (11). Individual YAC clones were identified by screening three-dimensional YAC pools with polymorphic markers, simple tandem repeat DNA polymorphisms (STRPs), genetically mapped to chromosome 20q, and STSs derived from genes localized to 20q, microdissection clones from 20q12–20q13.2, and YAC inter-Alu and vector-Alu fragments. DNA was prepared from all positive YACs, and the presence of the STS in that YAC confirmed by PCR.

Seventy-one markers were uniquely localized in the YAC contig. The order of STRPs placed in the genetic linkage map of chromosome 20 with odds >1000:1 (12) was confirmed in the contig map. In addition, STRPs showing no evidence for recombination in the genetic map—e.g., *D20S99* and *D20S107*—or not well mapped genetically—e.g., *D20S65*, *D20S465*, *D20S424*, and *D20S75*—could be precisely localized in the physical map.

The overlap between adjacent YACs is defined by at least two STS in all but two regions: UC9, an STS generated by vector-Alu PCR of 798E12, and *D20S176*. The overlap in these regions needs to be confirmed by screening additional YACs, P1, or BAC libraries with these markers. Several YAC clones appear to be unstable and prone to deletion as judged by inconsistencies in STS content mapping using different YAC DNA preparations and by PFGE—e.g., 765H11 is deleted for *SRC*—and the sizes of the YACs 857H11, 807B09, and 948D10 varied in independent DNA preparations as determined by PFGE analysis.

While it was possible to deduce STS order, the absolute physical size of the contig is not precisely known, as the distance between adjacent STSs has not been determined by PFGE. The presence of YACs that are chimeric or contain deletions can also confound the estimation of the physical size of the contig. We have attempted to overcome some of these problems by isolating multiple YACs for each STS and determining whether or not the YACs are chimeric by FISH. We estimate that the interval from *TGM2* to *EST391* is approximately 18 Mb based on the sum of the sizes of 20 YACs:

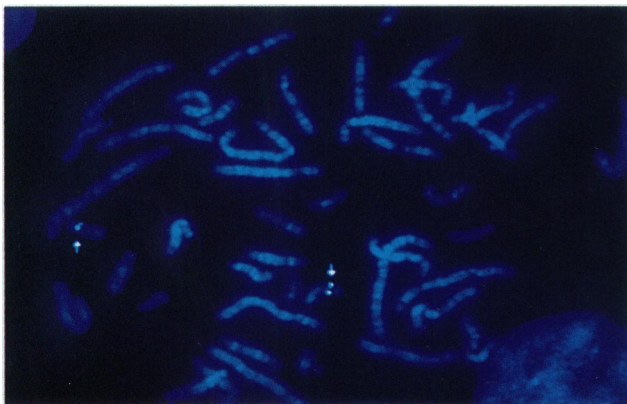

FIG. 3. FISH of YAC clone 948D12. In this example, the YAC DNA was recovered after PFGE prior to sequence independent amplification and hybridization to normal human metaphase chromosomes. There was no evidence for chimerism and a signal can only be seen in the distal part of chromosome 20, band q12.

Table 1. FISH analysis of chromosome 20 YACs

YAC address	Localization		YAC size, kb
	Chromosome 20	Other sites	
733D10	q13.2	6q24–25 1q31–32	500
765H11	q11.1–11.2	19p13.3	550
784B08	q12	5q31	1200
798E12	q13.1	16p13.2	650
807B09	q13.1	11q14, 18q21	950
808C05	q12	—	1000
822B06	q13.1 (proximal)	—	200
822E12	q13.1	—	500
845A08	q13.1	—	210
857H11	q13.1	—	850
869C05	q12–13.1 (junction)	—	600
903C02	q13.1	—	150
909F08	q13.2	—	800
909H05	q13.1–13.2 (junction)	12q14	950
928D10	q13.1	9q12	1100
936E04	q11.2	—	1200
936H03	q12	—	1400
942B01	q11.2	—	1400
945B09	q12	—	1500
948D12	q12–13.1 (junction)	—	800
948D10	q13.1	—	500
951F02	q13.1	Xq12	2000
953B04	q13.1	—	250
953C12	q11.2	6q12	950
981D02	q13.1	—	200

765H11, 858C12, 935F03, 942B01, 808C05, 945B09, 949E04, 936E04, 951F02, 909F08, 798E12, 909H05, 948D12, 822E12, 928D10, 948D10, 807B09, 845A08, 903C02, and 773G06. The sex-averaged genetic distance between *SRC* and *D20S196* is approximately 29 cM.

Several small YAC contigs proximal and distal to *TGM2* and *EST391*, respectively, were also isolated during the course of this study (Fig. 2). A contig containing *BCLX* and *HCK*, initially considered as candidates for the tumor suppressor gene in malignant myeloid disorders but now excluded based on their location, and the polymorphic markers *D20S111*, *D20S200*, and *D20S187*, were localized proximal to *TGM2*. Mutations at the agouti locus in mice are associated with obesity and diabetes. The human homolog of agouti, *AGTIL*, was localized in a small contig with *D20S195* and *D20S55*, a location which excludes *AGTIL* as being the locus responsible for MODY. As shown in Fig. 2A, exons 1 and 2 of *AGTIL* are located in different YACs indicating that the 5' end of this gene is oriented towards the centromere. Two small contigs from the region distal to *EST391* were also assembled, each comprising seven STSs, and nine and eight YACs, respectively (Fig. 2B); the melanocortin-3 receptor (*MC3R*) is in the more distal contig.

**Cytogenetic Localization of the Contig.** To verify the physical map and to test for the presence of chimeric clones, 25 of the 72 YACs shown in Fig. 1 were mapped to normal metaphase chromosomes by FISH. Seventeen YACs were not chimeric and mapped to chromosome 20 bands q11.1–q13.2 (Fig. 3 and Table 1). The inserts in these YACs contain ≈12 Mb of DNA. Thus, a substantial share of the interstitial portion of chromosome 20 can be isolated in nonchimeric clones which will facilitate the isolation of disease genes from this region since the YACs can be used directly to screen cDNA libraries and for exon trapping without worrying about isolating cDNA clones or exons from genes mapping to other chromosomes.

**Ordering of *RPN2*, *SRC*, and *RBL1* by FISH.** Dual-color FISH was used to order *RPN2*, *SRC*, and *RBL1* (p107) since the order of these genes could not be unambiguously deter-

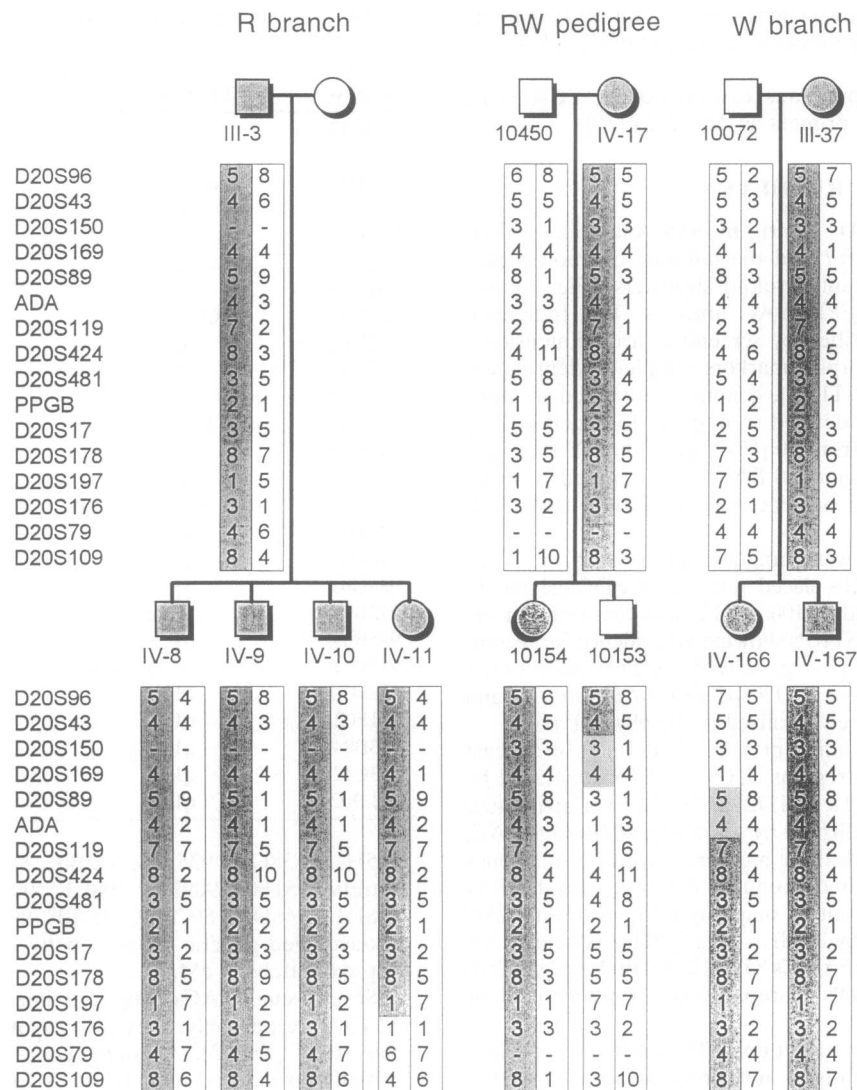

FIG. 4. Partial pedigree of the RW family showing haplotypes of key individuals for localizing *MODY1*. Of the W branch, III-37 and her offspring are described in figure 1 of ref. 2. IV-17, an offspring of III-3, and the subjects of the R branch have not been published. The numbers under the subjects of the W branch give repository numbers of immortalized cell lines stored in the National Institute of General Medical Sciences Human Genetic Mutant Cell Repository. Individuals with NIDDM are noted by black symbols (■). The marker genotypes and haplotypes are indicated. The at-risk haplotype is noted by shading, with the lighter shading indicating ambiguity in the transmitted haplotype.

mined by STS content analysis. Dual-color FISH to metaphase chromosomes indicated that *SRC* was proximal to *RBL1* (of 33 chromosomes examined, *SRC* was proximal to *RBL1* in 48%, *SRC* and *RBL1* signals were fused in 21%, and *SRC* was distal to *RBL1* in 27%). Hybridization of *SRC*- and *RBL1*-specific probes to interphase nuclei resulted in discrete signals that were well separated. In contrast, cohybridization of *RPN2* and *SRC* probes to interphase cells showed a fused signal suggesting that these genes were very close. Although the order of *RPN2* and *SRC* could not be deduced by interphase analysis, the results obtained by the analysis of leukemia cells with deletions or translocations of 20q suggest that *RPN2* was proximal to *SRC*. In one patient, the proximal breakpoint of an interstitial deletion of 20q occurred between the *RPN2* and *SRC* genes; *RPN2* was retained, whereas *SRC* was included in the deleted segment. In another patient with a t(17;20)(q21;q11.2), the breakpoint was between *SRC* and *RBL1* which was translocated to chromosome 17. Thus, the order was inferred to be cen-*RPN2*-*SRC*-*RBL1*-tel.

**Localization of Genes on the Physical Map.** Twenty known genes and six ESTs were placed on the contig by STS mapping. The locations of the genes in the physical map corresponded

well with previously reported genetic and cytogenetic assignments except for *TGM2* and *KCNB1*. *TGM2* was previously localized to 20q12 by FISH (13), whereas our data place it in band q11.2. Similarly, *KCNB1* was mapped to band q13.2 by FISH (14), and our data localize it to band q13.1.

**Localization of *MODY1*.** Previous studies have localized *MODY1* to a 13-cM interval between *PLCG1* and *D20S4* (3, 4). Using the markers shown in Fig. 1, we have refined the location of *MODY1* to an interval between *D20S169* and *D20S176*. The haplotypes of the key recombinants in the RW pedigree, the original pedigree in which this linkage was described and the only pedigree identified to date showing statistical evidence for linkage with markers on chromosome 20, are shown in Fig. 4.

## DISCUSSION

We have generated a physical map of a significant portion of the long arm of chromosome 20. This map is comprised of 71 overlapping YAC clones onto which we have ordered 71 markers including 20 genes, 5 ESTs, 32 STRPs and 14 STSs. The sex-averaged length of this region is 29 cM and the maximum physical length about 18 Mb. Thus, 1 cM corre-

sponds to  $\approx 620$  kb. Overall, the order of markers based on genetic or physical methods are in excellent agreement. Moreover, markers which were tightly linked genetically could be ordered on the physical map.

Chromosome bands 20q11.2–20q13.1 contain a putative tumor-suppressor gene involved in myeloid leukemias and a gene, *MODY1*, responsible for one form of early-onset NIDDM. A number of candidate genes for the putative tumor-suppressor gene have been mapped to the long arm of chromosome 20 including *BCLX*, a *BCL2*-related gene involved in regulating cell growth and apoptosis; *HCK*, a hematopoietic cell-specific tyrosine kinase gene; *E2F1*, *SRC*, *RBL1*, *TOP1*, *PLCG1*, and *PTPN1* (15, 16). *BCLX*, *HCK*, *E2F1*, and *PTPN1* lie outside the commonly deleted segment which extends from *RPN2* proximally to *D20S17* distally, and thus are excluded as being the putative suppressor gene. Of the other genes, *RBL1* may be the best candidate for a tumor-suppressor gene. This gene encodes the retinoblastoma-related protein p107 which is believed to play a role in regulating cellular proliferation. The protein p107 binds to cyclin D1-CDK4 and cyclin A-CDK2 complexes as well as to complexes of cyclin A-CDK2 and the transcription factors E2F/DP-1 and the binding is modulated during the cell cycle and by phosphorylation of p107 (17). In addition, p107 suppresses the transactivation domain of MYC and mutant MYC proteins are resistant to this suppression. Thus, disruption of a regulatory interaction between p107 and cyclin complexes or MYC may be important in the process of tumorigenesis (17, 18).

The *MODY1* gene product appears to be involved in the regulation of insulin secretion by pancreatic  $\beta$ -cells and clinical studies have shown that subjects with mutations in *MODY1* have an altered insulin secretory response to glucose that is evident even before the onset of overt NIDDM, suggesting that the primary defect affects insulin secretion/ $\beta$ -cell function rather than insulin action (19). Several candidates for *MODY1* have been mapped to chromosome 20. The agouti gene product, a paracrine signaling molecule which is expressed at highest levels in skin but whose ectopic expression can lead to obesity and diabetes, and phospholipase C, an intracellular second messenger encoded by *PLCG1*, are proximal to the *MODY1* region and thus excluded as being the disease-causing locus (14, 20). Similarly, the tyrosine phosphatase gene, *PTPN1*, which encodes a protein involved in intracellular signaling, is distal to *MODY1* and thus excluded. The cytosolic phosphoenolpyruvate carboxykinase gene, which encodes a key regulatory enzyme of gluconeogenesis, has been mapped to chromosome 20 and transgenic mice overexpressing this gene in liver develop NIDDM (21). The phosphoenolpyruvate carboxykinase gene, *PCK1*, has been mapped by FISH to 20q13.3, which is outside the *MODY1* interval, and linkage studies have shown that it is not tightly linked to *MODY1* (9).

Several candidate genes are located in the interval containing *MODY1*. Hepatocyte nuclear factor 4, *HNF4*, a transcription factor of the steroid hormone receptor superfamily, is expressed at high levels in liver, intestine, and kidney and at lower levels in endocrine pancreas and skin. It plays an important role in the regulation of genes of glucose (phosphoenolpyruvate carboxykinase and pyruvate kinase), fatty acid (medium chain acyl-CoA dehydrogenase), and lipoprotein metabolism (apolipoproteins AI, AII, AIV, CIII, and B) (22). *HNF4* deficiency is an embryonic lethal, and mice lacking this protein die due to a defect in gastrulation (23). However, heterozygous mice having only one functional gene will provide a useful model to test whether insulin secretion profiles are affected in these mice. Mutations in *ADA* and protective protein genes (*PPGB*) are associated with single-gene disorders, but diabetes is not a feature of severe-combined immunodeficiency or hemolytic anemia associated with adenosine deaminase deficiency or excess, respectively, or galactosialidosis. *SEMG*, *PI3*, *CD40*, and *KCNB1* are not expressed in human

pancreatic islets as judged by reverse transcriptase PCR (M.S., unpublished results) and are therefore unlikely causes of *MODY*; *KCNB1* is also excluded because it maps outside the *MODY1* interval.

In summary, we have established a long-range physical map of chromosome bands 20q11.2–20q13.1. The YAC contig which defines this map will be useful for the molecular characterization of myeloid leukemia deletions and linkage studies of *MODY* families. Moreover, it will facilitate the cloning of the genes responsible for these and other disorders.

We thank Anthony A. Fernald and Elizabeth M. Davis for technical assistance. These studies were supported by the Howard Hughes Medical Institute, U.S. Public Health Service Grants DK-20595 and CA-67021, and an unrestricted grant for cardiovascular research from Bristol-Myers/Squibb.

- DeFronzo, R. A., Bonadonna, R. C. & Ferrannini, E. (1992) *Diabetes Care* **15**, 318–368.
- Fajans, S. S., Bell, G. I., Bowden, D. W., Halter, J. B. & Polonsky, K. S. (1994) *Life Sci.* **55**, 413–422.
- Bell, G. I., Xiang, K. S., Newman, M. V., Wu, S. H., Wright, L. G., Fajans, S. S., Spielman, R. S. & Cox, N. J. (1991) *Proc. Natl. Acad. Sci. USA* **88**, 1484–1488.
- Rothschild, C. B., Akots, G., Fajans, S. S. & Bowden, D. W. (1992) *Genomics* **13**, 560–564.
- Roulston, D., Espinosa, R., III, Stoffel, M., Bell, G. I. & Le Beau, M. M. (1993) *Blood* **82**, 3424–3429.
- Hansmann, I. & Keith, T. (1993) in *Human Gene Mapping*, ed. Cuticchia, A. J. (Johns Hopkins Univ. Press, Baltimore), pp. 598–610.
- Bohlander, S. K., Espinosa, R., III, Le Beau, M. M., Rowley, J. D. & Diaz, M. O. (1993) *Genomics* **13**, 1322–1324.
- Chumakov, I. M., Gall, I. L., Billault, A., Ougen, P., Soularue, P., Guillou, S., Rigault, P., Bui, H., De Tand, M.-F., Barillot, E., Abderrahim, H., Cherif, D., Berger, R., Le Paslier, D. & Cohen, D. (1992) *Nat. Genet.* **1**, 222–225.
- Rowley, J. D., Diaz, M. O., Espinosa, R., III, Patel, Y. D., van Melle, E., Ziemin, S., Taillon-Miller, P., Lichter, P., Evans, G. A., Kersey, J. H., Ward, D. C., Domer, P. H. & Le Beau, M. M. (1990) *Proc. Natl. Acad. Sci. USA* **87**, 9358–9362.
- Stoffel, M., Xiang, K. S., Espinosa, R., III, Cox, N. J. & Bell, G. I. (1993) *Hum. Mol. Genet.* **2**, 1–4.
- Albertsen, H. M., Abderrahim, H., Cann, H. M., Dausset, J., Le Paslier, D. & Cohen, D. (1990) *Proc. Natl. Acad. Sci. USA* **87**, 4256–4260.
- Gyapay, G., Morissette, J., Vignal, A., Dib, C., Fizames, C., Millasseau, P., Marc, S., Bernardi, G., Lathrop, M. & Weissenbach, J. (1994) *Nat. Genet.* **7**, 246–340.
- Gentile, G., Davies, P. J. A. & Baldini, A. (1994) *Genomics* **20**, 295–297.
- Melis, R., Stauffer, D., Zao, X., Zhu, X. L., Albrecht, B., Pongs, O., Brothman, A. & Leppert, M. (1994) *Genomics* **25**, 285–287.
- Boise, L. H., Gonzalez-Garcia, M., Postema, C. E., Ding, L., Lindsten, T., Turka, L. A., Mao, X., Nunez, G. & Thompson, C. B. (1993) *Cell* **74**, 597–608.
- Quintrell, N., Lebo, R., Varmus, H., Bishop, J. M., Pettenati, M. J., Le Beau, M. M., Diaz, M. O. & Rowley, J. D. (1987) *Mol. Cell. Biol.* **6**, 2267–2275.
- Beijersbergen, R. L., Carlee, L., Kerkhoven, R. M. & Bernards, R. (1995) *Genes Dev.* **9**, 1340–1353.
- Gu, W., Bhatia, K., Magrath, I. T., Dang, C. V. & Dalla-Favera, R. (1994) *Science* **264**, 251–254.
- Byrne, M. M., Sturis, J., Fajans, S. S., Oritz, F. J., Stoltz, A., Stoffel, M., Smith, M. J., Bell, G. I., Halter, J. B. & Polonsky, K. S. (1994) *Diabetes* **44**, 699–705.
- Wilson, W. D., Ollmann, M. M., Kang, L., Stoffel, M., Bell, G. I. & Barsh, G. S. (1995) *Hum. Mol. Genet.* **4**, 223–230.
- Valera, A., Pujol, A., Pelegrin, M. & Bosch, F. (1994) *Proc. Natl. Acad. Sci. USA* **91**, 9151–9154.
- Sladek, F. M. (1994) in *Liver Gene Expression*, eds Tronche, F. & Yaniv, M. (Landes, Austin, TX), pp. 207–223.
- Chen, W. S., Manova, K., Weinstein, D. C., Duncan, S. A., Plump, A. S., Prezioso, V. R., Bachvarova, R. F. & Darnell, J. E., Jr. (1994) *Genes Dev.* **8**, 2466–2477.