



Published in final edited form as:

*Mamm Genome*. 2014 April ; 25(0): 160–179. doi:10.1007/s00335-014-9500-8.

## A Genetic Map of *Peromyscus* with Chromosomal Assignment of Linkage Groups (A *Peromyscus* Genetic Map)

**Jane Kenney-Hunt,**

Department of Biological Sciences and *Peromyscus* Genetic Stock Center, University of South Carolina, Columbia, SC 29208, USA

**Adrienne Lewandowski,**

Department of Biological Sciences and *Peromyscus* Genetic Stock Center, University of South Carolina, Columbia, SC 29208, USA

**Travis C. Glenn,**

Savannah River Ecology Laboratory, University of Georgia, Aiken, SC 29801, USA

**Julie L. Glenn,**

Department of Biological Sciences and *Peromyscus* Genetic Stock Center, University of South Carolina, Columbia, SC 29208, USA

Savannah River Ecology Laboratory, University of Georgia, Aiken, SC 29801, USA

**Olga V. Tsyusko,**

Savannah River Ecology Laboratory, University of Georgia, Aiken, SC 29801, USA

**Rachel J. O'Neill,**

Department of Molecular and Cell Biology, University of Connecticut, Storrs, CT 06269-2131, USA

**Judy Brown,**

Department of Molecular and Cell Biology, University of Connecticut, Storrs, CT 06269-2131, USA

**Clifton M. Ramsdell,**

Department of Biological Sciences and *Peromyscus* Genetic Stock Center, University of South Carolina, Columbia, SC 29208, USA

**Quang Nguyen,**

Department of Biological Chemistry, University of California, Irvine CA 92799, USA

**Tony Phan,**

Department of Biological Chemistry, University of California, Irvine CA 92799, USA

**Kimberly S. Shorter,**

Department of Biological Sciences and *Peromyscus* Genetic Stock Center, University of South Carolina, Columbia, SC 29208, USA

**Michael J. Dewey,**

---

Corresponding authors: M. R. Felder (mrfelder@mailbox.sc.edu; 803 777 5135) or P. B. Vrana (vrnap@mailbox.sc.edu; 803 777 4946).

Present Address:

J. P. Kenney-Hunt - Department of Biology and Environmental Science, Westminster College, Fulton, MO 65251, USA

T. C. Glenn, J. L. Glenn - Department of Environmental Health Science, University of Georgia, Athens, GA 30602-7396, USA

O. V. Tsyusko - Department of Plant and Soil Sciences, University of Kentucky, Lexington, KY 40546-0091, USA

C. M. Ramsdell - Gene Expression Division, Bio-Rad Laboratories, 2000 Alfred Nobel Drive, Hercules, CA 94547, USA

J. Brown - Department of Allied Health Sciences, University of Connecticut, Storrs, CT 06269, USA

Department of Biological Sciences and *Peromyscus* Genetic Stock Center, University of South Carolina, Columbia, SC 29208, USA

**Gabor Szalai,**

Department of Biological Sciences and *Peromyscus* Genetic Stock Center, University of South Carolina, Columbia, SC 29208, USA

**Paul B. Vrana, and**

Department of Biological Sciences and *Peromyscus* Genetic Stock Center, University of South Carolina, Columbia, SC 29208, USA

**Michael R. Felder**

Department of Biological Sciences and *Peromyscus* Genetic Stock Center, University of South Carolina, Columbia, SC 29208, USA

## Abstract

The rodent genus *Peromyscus* is the most numerous and species rich mammalian group in North America. The naturally occurring diversity within this genus allows opportunities to investigate the genetic basis of adaptation, monogamy, behavioral and physiological phenotypes, growth control, genomic imprinting, and disease processes. Increased genomic resources including a high quality genetic map are needed to capitalize on these opportunities. We produced interspecific hybrids between the prairie deer mouse (*Peromyscus maniculatus bairdii*) and the oldfield mouse (*Peromyscus polionotus*) and scored meiotic recombination events in backcross progeny. A genetic map was constructed by genotyping of backcross progeny at 185 gene-based and 155 microsatellite markers representing all autosomes and the X chromosome. Comparison of the constructed genetic map with the molecular maps of *Mus* and *Rattus* and consideration of previous results from interspecific reciprocal whole chromosome painting allowed most linkage groups to be unambiguously assigned to specific *Peromyscus* chromosomes. Based on genomic comparisons, this *Peromyscus* genetic map covers approximately 83% of the *Rattus* genome and 79% of the *Mus* genome. This map supports previous results that the *Peromyscus* genome is more similar to *Rattus* than *Mus*. For example, coverage of the 20 *Rattus* autosomes and the X chromosome is accomplished with only 28 segments of the *Peromyscus* map, but coverage of the 19 *Mus* autosomes and the X chromosome requires 40 chromosomal segments of the *Peromyscus* map. Furthermore, a single *Peromyscus* linkage group corresponds to about 91% of the rat and only 76% of the mouse X chromosomes.

## Introduction

Members of the genus *Peromyscus* constitute the most numerous and species rich group of mammals in North America. The best known members of the genus are the deer mouse (*P. maniculatus*) and the white-footed mouse (*P. leucopus*). *Peromyscus* species have an appearance superficially similar to old world mice (e.g., species of the genera *Mus* or *Apodemus*), but represent a distantly related lineage. *Mus* and *Rattus* diverged approximately 10-12 million years ago, while their most recent common ancestor with the deer mouse was ca. 25-40 million years ago (Steppan et al. 2004).

Basic research of *Peromyscus* biology covers a variety of disciplines. *Peromyscus* occur in a wide range of habitats including sea-level wetlands, beaches, forests, deserts, and elevations up to 14,000 feet. Thus, these animals are ideal for studies on the genetic basis of adaptation to different environmental conditions, such as the genetic basis of coat color (Hoekstra et al. 2006; Linnen et al. 2009) and adaptation to life at high altitudes (Storz et al. 2011; Storz et al. 2010; Storz et al. 2009). Their ubiquitous presence in North America also means that *Peromyscus* are found at many sites contaminated with toxic chemicals and may be useful as

biomarkers of contamination. *Peromyscus* have been employed in numerous studies on the responses to chemicals, such as PCBs (Voltura and French 2007) and Aroclor 1254 (Wu et al. 1999) as well as being used to demonstrate transgenerational effects of BPA exposure (Jasarevic et al. 2011).

*Peromyscus* species carry several pathogens important to public health. For example, *P. maniculatus* acts as the primary carrier of Sin Nombre virus responsible for hantaviral pulmonary syndrome (Hjelle et al. 1995; Nichol et al. 1993). *P. leucopus* plays a role in the transmission of Lyme disease, both harboring the spirochaete *Borrelia burgdorferi* and acting as the host species for the larval stage of the tick which transmits the bacteria to humans (Anderson et al. 1987; Magnarelli et al. 1988).

*Peromyscus* has also been used to study behavioral and environmental effects on physiology and endocrinology (Bester-Meredith and Marler 2003; Martin et al. 2008a; Pyter et al. 2006; Trainor et al. 2007; Trainor et al. 2010) as well as immunology (Martin et al. 2007; Martin et al. 2008b; Pyter et al. 2005). Other phenotypic differences could inform our understanding of repetitive movements common in obsessive-compulsive disorder (Korff et al. 2008; Tanimura et al. 2010), while still others could address the relationship between blood glucose regulation and stress (Oriol et al. 2008). *Peromyscus* is also a potentially useful model for studying the genetic basis of monogamy and polygamy (Foltz 1981; Ribble 1991; Turner et al. 2010). Perhaps most useful of all is the ability of some species of *Peromyscus* to hybridize in the laboratory. This ability has allowed development of unique mammalian models of hybrid dysgenesis (including severe developmental defects) and epigenetic misregulation (Duselis and Vrana 2010; Vrana et al. 1998; Vrana et al. 2013).

Despite the wide range of habitat types in which *Peromyscus* occur, members of the genus are easily reared under standard *Mus* husbandry conditions (Dewey and Dawson 2001), thus making it possible to determine the genetic basis of naturally occurring variants through the use of controlled crosses in the laboratory. Two species are of particular importance in genetic analysis: the prairie deer mouse, *P. maniculatus bairdii*, and the oldfield mouse, *P. polionotus*. Hybrids produced by mating *P. maniculatus* females with *P. polionotus* males are viable and fertile, thus allowing genetic analysis of important phenotypic differences between the species and natural variants within these species. These species differ markedly in many characteristics where variation is not found in other well-established mammalian models such as *Mus* and *Rattus*. Although extensive genetic and genomic tools are available for *Mus* and *Rattus*, *Peromyscus* genomic resources are still being developed to enhance the utility of *Peromyscus* as an experimental system. Approximately 79,000 *P. maniculatus* expressed sequence tags (ESTs) from various tissues have deposited in GenBank. Approximately 2900 ESTs from testes and placenta have been more thoroughly analyzed with many assigned to *Mus* or *Rattus* chromosomes or a biological function (Glenn et al. 2008). Additional transcriptome sequencing has been conducted (e.g., Genbank accessions GH457086.1 - GH545901.1), but the summaries have not yet been published. Whole genome sequencing of *P. maniculatus*, *P. polionotus*, *P. leucopus* and *P. californicus* has been completed, and assembly of the genomes is underway (<https://www.hgsc.bcm.edu/content/Peromyscus-genome-project>).

Even with the nascent genomic resources, the utility of *Peromyscus* as a model for modern genetic research will be significantly enhanced by a linkage map with the position of markers on chromosomes derived from traditional genetic mapping methods. A linkage map of *Peromyscus* will facilitate genome assembly and increase researchers' ability to identify genes associated with phenotypic variation and/or involved in important biological processes.

Two nascent genetic maps of *Peromyscus* have already been constructed, however, there is little useful overlap between the two. Nearly 80 genes have been mapped and assigned to several linkage groups (Ramsdell et al. 2008) in which comparative linkage analysis revealed greater synteny and gene order conservation between *Peromyscus* and *Rattus* than between *Peromyscus* and *Mus*. A second genetic map was produced by (Steiner et al. 2007) using ca. 120 markers, mostly microsatellites. This map focused on the location of genes controlling adaptive coat color in the light-pigmented beach mice, *P. polionotus leucocephalus*. Although useful in their own right, the small amount of overlap in genetic markers used in the two studies allows little ability to merge the two genetic linkage maps into one with greater marker density.

Here we report on the development of a marker-dense genetic map suitable for a great diversity of studies. By increasing the genomic resources available for this genus, the unique and significant phenotypic differences found within *Peromyscus* may finally make discovering the genetic bases of these phenotypes tractable. A genetic map, therefore, is essential for further development of these animals as a model system and to exploit their large potential as a mammalian small animal research model.

## Materials and methods

Animals used in this study were from the *P. maniculatus* (BW) and *P. polionotus* (PO) stocks maintained at the *Peromyscus* Genetic Stock Center, University of South Carolina (<http://stkctr.biol.sc.edu>). Animal care is provided by the University of South Carolina Animal Care Facility which is fully accredited by American Laboratory Animal Care Committee. The research described here was approved by the University of South Carolina IACUC.

### Development of backcross panels for genetic mapping

The mapping of autosomal genes was done using a *P. maniculatus* × (*P. maniculatus* × *P. polionotus*) F<sub>1</sub> backcross panel. Twenty-two progeny from each of four different backcross families were used for analysis (i.e. for a total of 88 animals). Mapping of X-linked loci was done using a panel of offspring from a backcross of (*P. maniculatus* × *P. polionotus*) F<sub>1</sub> × *P. polionotus*. This panel consisted of 145 animals from ten different matings (families).

DNA from liver tissue of all parents and backcross progeny was isolated using standard SDS/proteinase K and phenol/chloroform methods (Maniatis et al. 1982) or via the Qiagen DNeasy Blood & Tissue Kit. DNA concentration and quality were assessed by using ratio of absorbance at 260 and 280 nm.

### Development of gene based PCR marker assays

Primers were developed from *P. maniculatus* EST sequences (Glenn et al. 2008) as previously described (Ramsdell et al. 2008). Selected genes were also targeted by designing primers based on conserved mammalian sequences as previously described (Loschiavo et al. 2007; Ramsdell et al. 2008)

### PCR methods

Qiagen HotStarTaq and HotStarTaqPlus kits were used for amplification of specific DNA sequences for individual genes. Conditions were as suggested by the supplier with some optimization for different genes. The PCR cycling conditions for HotStarTaqPlus (HSP) were 95°C for 5 min followed by 35 cycles of: 95°C for 30s, annealing for 30s at temperatures between 48-65°C depending on the gene, 72°C for 30s per 0.5kb, 72°C for 10 min, 4°C hold. HotStarTaq (HS) used 14.5 min for the initial denaturation at 95°C. The

same basic conditions were used for Touchdown PCR and were as follows: (1) TD65HSP used 20 cycles with annealing at 65°C for 30s minus 0.5 °C/cycle followed by 20 cycles with annealing at 55°C; (2) TD60HSP and TD55HSP used starting annealing temperatures of 60°C and 55°, respectively, and ramped down over 20 cycles by 10°C followed by 20 cycles at the lower temperature. HotStarTaq was also used in touchdown protocols with just the longer initial denaturation temperature and are referred to as TD65HS, TD60HS or TD55HS. Amplification of some DNA sequences required additional MgCl<sub>2</sub> or Qiagen Q-solution. Some loci were amplified using Invitrogen Taq Polymerase with the suggested methods; this was the method used when only annealing temperature is given in Appendix 1. Amplification products were digested with the appropriate restriction endonuclease and digestion products were resolved on 2% agarose or 7.5 polyacrylamide gels, depending on the size of fragments to be resolved.

### Microsatellite genotyping

Primers and amplification methods of microsatellites were as previously described (Weber et al. 2010). Genotyping of some loci was done by analyzing amplification products on agarose or polyacrylamide gels of appropriate concentration for the size of the amplification product.

### Screening of BAC library

The *Peromyscus maniculatus rufinus* BAC library CHORI-233 was obtained from the BACPAC Resources of the Children Hospital Oakland Research Institute (<http://bacpac.chori.org/library.php?id=280>). Specific primers (see Table 1) were used to produce DNA fragments for the genes *Pacrg*, *Hba*, and *Mpo*. The fragments were gel purified, radiolabeled by random priming (Manufacturer's instructions) and used all together to probe the 5 filters representing the library. Clones identified by hybridization were obtained from BACPAC resources, and the BACs were purified and rescreened by Southern blotting methods using the individual probes.

### Fluorescence *in situ* hybridization

Confluent cell cultures of *Peromyscus maniculatus* fibroblasts were treated with colcemid, harvested by centrifugation, resuspended in hypotonic solution and washed with 3:1 methanol:acetic acid. Chromosomes were spread on dry, acetone cleaned slides per standard protocols, air-dried overnight, and dehydrated in an ethanol series.

Chromosome paint FISH was performed as previously described (Mlynarski et al. 2008). BAC DNA probes were labeled with fluorescein-12-dUTP (green), Texas Red-5-dUTP (red) or Diethylaminocoumarin-5-dUTP (aqua) by nick-translation per manufacturer's protocol (Roche 11745808910). 50 ng of labeled BAC DNA with 1 µg of Cot1 in Hybrisol VII (Qbiogene) was hybridized to denatured slides under a sealed coverslip at 37° C in a humid chamber for 20 hours. Slides were washed at 72° C in 0.4XSSC and subsequently counterstained with a 1:3 dilution of DAPI in Vectashield (Vector Laboratories). Images were captured on an Olympus AX70 fluorescence microscope equipped with appropriate filters and a CCD camera. Images were analyzed with Genus (Applied Imaging). Chromosome identification was made by examining inverted DAPI banding of probe hybridizations and confirmed by FISH (for all but BAC 402) using flow-sorted chromosome paints.

### Construction of genetic linkage maps

Linkage maps were created using JoinMap 4 (Kyazma B.V., Wageningen, Netherlands). The mapping population included 86 individuals in four families genotyped at 340

polymorphic loci resulting from a backcross (described above). Linkage groups were determined by a LOD score of 4.0. Regression maps were created from the linkage groups using Kosambi's function. Identical methods were used to map X-linked genes in the 145 backcross progeny derived from the (*P. maniculatus* × *P. polionotus*)F<sub>1</sub> × *P. polionotus* cross.

### Assignment of linkage groups to specific chromosomes

The linkage groups were assigned to specific *Peromyscus* chromosomes using the results of reciprocal hybridization of isolated whole *Mus* and *Rattus* chromosomes with *Peromyscus* chromosome spreads with visualization by FISH (Mlynarski et al. 2008). Comparisons of the *Peromyscus* genetic map with the *Mus* and *Rattus* molecular maps (Sinha and Meller 2007) also aided in assignment. The standardized *Peromyscus* cytogenetic nomenclature (Greenbaum et al. 1994) was used for identification of *Peromyscus* chromosomes.

## Results

### Development of gene-based markers

The genes for which methods have been developed for genotyping of allelic variants are listed in Appendix 1. Also given are the primers used for amplification, the PCR conditions for production of the DNA amplification product, and the restriction enzyme used to differentiate BW and PO allelic products. Few BW and PO initial amplification products differ in size and those are listed in the table along with the method of resolution by either agarose or acrylamide gel electrophoresis.

### *Peromyscus* genetic map covering all autosomes and the X-Chromosome

A genetic map of the *Peromyscus* genome based upon recombination frequency between markers among the backcross progeny is shown in Fig. 1. The genetic map shows the locations of 185 gene and 155 microsatellite loci for a total of 340 markers.

Initially, one more autosomal linkage group was detected than there are autosomes in *Peromyscus*. Two linkage groups are associated with *Peromyscus* chromosome 8. Confirmation of this association was obtained from FISH analysis using labeled BAC chromosomes harboring specific genes on the two linkage groups (Fig. 2). The *P. maniculatus* CHORI-233 BAC clones which harbor the *Hba*, *Pacrg* and *Mpo* genes are 501B24, 396H17 and 312P13, respectively. *Hba* was not placed on the genetic map using this backcross panel data although it was very loosely associated with *Canx* on chromosome 8b. Thus, *Hba* was used as a marker possibly located near the end of the linkage group assigned to chromosome 8a. The previous linkage group constructed using the female as the hybrid animal did show linkage between *Hba* and *Canx* on chromosome 8 (Ramsdell et al. 2006).

The orientation of the two linkage groups on chromosome 8 as suggested by FISH analysis is shown in Fig. 2A. The FISH analysis using the *Hba*-harboring BAC clone (labeled red), and the *Pacrg*-harboring BAC clone (labeled green) is shown in Fig. 2B. As can be seen, the *Hba* signal is located proximal to the centromere whereas the *Pacrg* gene is located more distally. The location of *Hba* and *Mpo* (aqua labeled) determined by FISH is shown in Fig. 2C, and *Mpo* and *Pacrg* are very close together on the chromosome. This proximity is confirmed in Fig. 2D where both green and aqua are visualized and their position overlaps. From these data, we infer that the two linkage groups are in the order shown in Fig. 2A.

## Comparative analysis of linkage relationships between *Peromyscus*, *Rattus* and *Mus*

The *Peromyscus* genetic linkage map is compared to the *Rattus* and *Mus* molecular maps in Fig. 3. In a few instances, the order of genes not resolved by recombination events is inferred based upon the molecular order in the *Rattus* and *Mus* genomes (i.e. areas of *Peromyscus* chromosomes 1, 2, 8b, 10 and 12). Given these assumptions, synteny, as well as gene order, is conserved between chromosome 1 and much of *Rattus* Chr 1 and a significant portion of *Mus* Chr 7. Synteny, and gene order, is conserved between *Peromyscus* chromosomes 6, 11 and 20 and both *Rattus* and *Mus* corresponding genomic regions. Other regions of shared synteny are extensive but have single or multiple inversion and/or insertion differences between the *Peromyscus* map and the other two species.

While the *Peromyscus* map contains regions of low marker density, the map size suggests it covers much of the genome based on comparisons to *Rattus* and *Mus* genomes (Fig.4). In addition, fewer and longer *Peromyscus* genetic map segments are involved in the coverage of the *Rattus* genome than the *Mus* genome.

A summary of those portions of the *Peromyscus* genetic map sharing synteny with *Mus* or *Rattus* is given in Table 1. Longer regions of shared synteny, including shared gene order, occur between *Peromyscus* and *Rattus* than occur with *Mus* (Table 1). Longer syntenic segments without complete gene co-linearity are also conserved between *Peromyscus* and *Rattus* than between *Peromyscus* and *Mus*. When compared to the *Rattus* and *Mus* molecular maps, the current *Peromyscus* genetic map has regions of synteny conservation and total size representing approximately 83% of the *Rattus* and 79% of the *Mus* genomes.

## Assignment of linkage groups to *Peromyscus* chromosomes

The *Peromyscus* genetic map as linkage groups conditionally assigned to chromosomes, and orientation of the linkage group was possible on some *Peromyscus* chromosomes. The linkage groups on *Peromyscus* chromosomes 1, 5 and 10 are aligned with the short arm of the chromosome at the top of the illustrated linkage group based on correlation between the comparative map and hybridization to *Mus* isolated whole chromosomes. *Peromyscus* Chr 2 has a gap in hybridization to *Mus* Chr 4 possibly due to the insertions of *Mus* Chr1 and *Mus* Chr 3 homologous, short sequences revealed in the comparative map somewhere near the centromere region. This suggests this linkage group also is aligned with the short arm of *Peromyscus* Chr 2 at the top.

The complexity of *Peromyscus* Chr 8 is revealed by both comparative mapping and hybridization analysis. Hybridization of *Mus* whole chromosome probes correlates with the comparative mapping, strongly confirming the chromosome assignment of the linkage group. Only hybridization to *Mus* Chr 4 was not revealed previously (although this is based on a single marker). The longest regions of the rat genome containing orthologous genes mapped to *Peromyscus* chromosome 8 are on chromosomes 1 and 10; both these rat chromosomes also have sequences hybridizing to *Peromyscus* chromosome 8.

Linkage groups assigned to Chr 21 and Chr 22 are tentative. While Chr 21 has sequences homologous to *Mus* Chr 17, hybridization of *Rattus* Chr 9 was not detected to this chromosome. A similar situation holds for *Peromyscus* Chr 22, with *Mus* Chr 10 hybridizing but not the other chromosomes containing orthologous genes. Further, *Rattus* Chr 6 contains orthologous genes to *Peromyscus* Chr 22 but does not show hybridization. These inconsistencies are likely the result of the small size of these chromosomes.

All other *Peromyscus* chromosomes are assigned a single linkage group consistent with their hybridization to single *Rattus* and *Mus* chromosome regions that contain orthologous genes.

Orientation of the linkage group on these chromosomes could not be determined. All X-linked genes identified in *Peromyscus* are also X-linked in both *Mus* and *Rattus*. Extensive inversion differences exist between the species, however.

## Discussion

This medium density genetic map represents a major advance in *Peromyscus* laboratory genetics. The gene-based markers mapped here will provide important and useful landmarks in the genome, while the microsatellites will aid in fine-mapping of phenotypic traits.

The *Peromyscus* genetic map covers approximately 83% of the *Rattus* and 79 % of the *Mus* genomes. The entire *Peromyscus* genetic map presented here including the X chromosome is 1499 cM in length compared to 1445 cM for *Mus* (Cox et al. 2009) and 1503 cM for *Rattus* (Brown et al. 1998). Approximately 20 percent of the *Peromyscus* genome is likely not included in the current genetic map. Thus, identification and assignment of additional markers to the map would appear to make the *Peromyscus* linkage map larger than that of *Mus* or *Rattus*. A recent linkage map constructed for the prairie vole (*Microtus ochrogaster*) suggested to cover about 90% of the genome was 1707 cM in length, based on recombination analysis in both sexes (McGraw et al. 2011). Thus, the *Peromyscus* genetic map may be closer in size to that of the prairie vole.

There is confidence in the identity of synteny and homologous relationships between the *Peromyscus* linkage map and the genome of other species including assignment of linkage groups to chromosomes. This is primarily due to supporting FISH studies and the number of gene-based markers used in map construction. The FISH studies (Mlynarski et al. 2008) using both isolated chromosomes from *Mus* and *Rattus* as probes on *Peromyscus* chromosome spreads as well as the reciprocal were further supported by synteny relationships between *Mus* and *Rattus* at the molecular level (Sinha and Meller 2007).

However, minor differences are observed between results with the reciprocal chromosomal hybridization studies and older ones using only isolated chromosomes of a single species for hybridization analysis on *Peromyscus* chromosome spreads. For example, previous FISH analysis using only *Mus* chromosome paint probes indicated that *Mus* Chr 3 hybridized to two regions of *Peromyscus* Chr 3 (Dawson et al. 1999). However, the use of both *Mus* and *Rattus* chromosome probes suggests *Mus* Chr 3 and *Rattus* Chr 2 correspond to *Peromyscus* Chr 6 (Mlynarski et al. 2008) and large regions of synteny between *Mus* Chr 3 and *Rattus* Chr 2 exists at the molecular level (Sinha and Meller 2007) supporting this conclusion. The *Peromyscus* linkage group assigned to Chr 6 is syntenic with a long region of *Rattus* Chr 2 and *Mus* Chr 3.

Previous FISH analysis with three *Mus* paint probes that suggested hybridization of *Mus* Chr 7 and Chr 9 to *Peromyscus* Chr 1 and Chr 7, respectively (Dawson et al. 1999), are in complete agreement with the results using both *Mus* and *Rattus* chromosome probes (Mlynarski et al. 2008). However, most of *Mus* Chr 3 was presumed to hybridize to two regions of *Peromyscus* Chr 3 (Dawson et al. 1999), but the cross-species whole chromosome FISH using both *Rattus* and *Mus* isolated chromosomes as probes suggested *Mus* Chr 3 hybridizes entirely to *Peromyscus* Chr 6 as does *Rattus* Chr 2 (Mlynarski et al. 2008).

The use of both *Mus* and *Rattus* whole chromosome probes on *Peromyscus* chromosome spreads provides additional evidence of the homology relationships between *Peromyscus* Chr 6, *Rattus* Chr 2 and *Mus* Chr 3. Moreover, *Peromyscus* Chr 3 hybridizes entirely with *Rattus* Chr 4 and *Mus* Chr 6 to a considerable extent with only the proximal region of the long arm of *Peromyscus* Chr 3 hybridizing to *Mus* Chr 5. These results are supported by the



synteny relationships between *Mus* and *Rattus* analyzed at the sequence level (Sinha and Meller 2007). *Peromyscus* chromosomes 3 and 6 are of similar overall size with similar centromere position and somewhat similar banding pattern (Greenbaum et al. 1994) possibly accounting for this discrepancy.

Despite attempts to unify chromosome 8 via additional markers predicted to map to this region, no linkage was obtained. One explanation for the anomalous chromosome 8 results is that this region contains a recombination hotspot, possibly induced by the inter-specific hybridization. Interestingly, the *Prdm9* locus is located within this region. *Prdm9* encodes a histone methyltransferase which has been implicated in determining recombination hotspots (Baudat et al. 2010). Moreover, *Prdm9* has been implicated in reproductive isolation between *Mus musculus musculus* and *Mus musculus domesticus* (Mihola et al. 2009). *P. maniculatus* and *P. polionotus* have been shown to differ in the number of zinc-finger domains encoded by this locus (Oliver et al. 2009) consistent with the hypothesis that *Prdm9* plays a role in this phenomenon.

This study also offers insights into chromosomal evolution. For example, prior studies have indicated inversions in *P. polionotus* relative to *P. maniculatus* on chromosomes 5, 6 and 14 (Greenbaum and Baker 1978). Despite these inversions, there is no obvious evidence of inhibition of recombination as might be predicted. However, each of these chromosomes has substantial regions with a paucity of markers. Thus, increasing marker density may yet reveal regions of inhibited recombination. The nascent genome sequences of both BW and PO will aid in such efforts.

This combination of the genetic map and genomes will allow immediate genetic characterization and gene discovery of natural variants and mutants within the *Peromyscus* species complex, such as those maintained at the *Peromyscus* Genetic Stock Center (PGSC, <http://stkctr.biol.sc.edu/>). That is, rigorous positional cloning approaches are now feasible.

Future resource development will include greatly increasing the density of this map through traditional and newer genome wide approaches such as RAD-seq (Davey et al. 2011) which can be used for gene discovery and facilitating increased density of the genetic map. This approach has recently been used to identify regions in the genome controlling the complex behavior of nest-building in *Peromyscus* (Weber et al. 2013). The results suggested that at least three genetic regions on different linkage groups control this behavior which is consistent with the previous suggestion based on genetic analysis that two or more loci control this phenotype (Dawson et al. 1988). Other differences between these two species that might be similarly investigated include differences in repetitive behavior (Shorter et al., submitted), mating system, cholesterol levels (Wiedmeyer et al., submitted) as well as the aforementioned differences in genomic imprinting/growth control and glucose homeostasis.

## Acknowledgments

This work was supported primarily by NIH GM069601 (MJD, TG), and also by NIH P40 OD010961 (MRF,GS) and NSF 0444165 (MRF, GS). We thank the Colony Manager of the *Peromyscus* Genetic Stock Center, Janet Crossland, for invaluable help in breeding and record keeping of the animals. We thank M. Peters, T. Tuberville, S. Lance, K. Jones, A. McKee for assistance in genotyping of microsatellite loci.

## References

- Anderson JF, Johnson RC, Magnarelli LA, Hyde FW, Andreadis TG. New infectious spirochete isolated from short-tailed shrews and white-footed mice. *J. Clin. Microbiol.* 1987; 25:1490–1494. [PubMed: 3305565]

- Baudat F, Buard J, Grey C, Fledel-Alon A, Ober C, Przeworski M, Coop G, de Massy B. PRDM9 is a major determinant of meiotic recombination hotspots in humans and mice. *Science*. 2010; 327:836–840. [PubMed: 20044539]
- Bester-Meredith JK, Marler CA. The Association Between Male Offspring Aggression and Paternal and Maternal Behavior of *Peromyscus* Mice. *Ethology*. 2003; 109:797–808.
- Brown DM, Matise TC, Koike G, Simon JS, Winer ES, Zangen S, McLaughlin MG, Shiozawa M, Atkinson OS, Hudson JR Jr, Chakravarti A, Lander ES, Jacob HJ. An integrated genetic linkage map of the laboratory rat. *Mamm Genome*. 1998; 9:521–530. [PubMed: 9657848]
- Cox A, Ackert-Bicknell CL, Dumont BL, Ding Y, Bell JT, Brockmann GA, Wergedal JE, Bult C, Paigen B, Flint J, Tsaih SW, Churchill GA, Broman KW. A new standard genetic map for the laboratory mouse. *Genetics*. 2009; 182:1335–1344. [PubMed: 19535546]
- Davey JW, Hohenlohe PA, Etter PD, Boone JQ, Catchen JM, Blaxter ML. Genome-wide genetic marker discovery and genotyping using next-generation sequencing. *Nature Reviews Cancer*. 2011; 12:499–510.
- Dawson WD, Lake CE, Schumpert SS. Inheritance of burrow building in *Peromyscus*. *Behavior Genetics*. 1988; 18:371–382. [PubMed: 3219114]
- Dawson WD, Young SR, Wang Z, Liu LW, Greenbaum IF, Davis LM, Hall BK. Mus and *Peromyscus* chromosome homology established by FISH with three mouse paint probes. *Mamm Genome*. 1999; 10:730–733. [PubMed: 10384049]
- Duselis AR, Vrana PB. Aberrant Growth and Pattern Formation in *Peromyscus* Hybrid Placental Development. *Biology of Reproduction*. 2010; 83:988–996. [PubMed: 20702850]
- Glenn JL, Chen CF, Lewandowski A, Cheng CH, Ramsdell CM, Bullard-Dillard R, Chen J, Dewey MJ, Glenn TC. Expressed sequence tags from *Peromyscus* testis and placenta tissue: analysis, annotation, and utility for mapping. *BMC Genomics*. 2008; 9:300. [PubMed: 18577228]
- Greenbaum IF, Baker RJ. Determination of the primitive karyotype for *Peromyscus*. *J. Mammalogy*. 1978; 59:820–834.
- Greenbaum IF, Gunn SJ, Smith SA, McAllister BF, Hale DW, Baker RJ, Engstrom MD, Hamilton MJ, Modi WS, Robbins LW, Rogers DS, Ward OG, WD D, Elder FFB, Lee MR, Pathak S, Stangle FBJ. Cytogenetic nomenclature of deer mice, *Peromyscus* (Rodentia): revision and review of the standardized karyotype. *Cytogenet Cell Genet*. 1994; 66:181–195. [PubMed: 8125018]
- Hjelle G, Krolkowski J, Torrez-Martinez N, Chavez-Giles F, Vanner C, Laposata E. Phylogenetically distinct hantavirus implicated in a case of hantavirus pulmonary syndrome in the northeastern United States. *J. Med. Virol*. 1995; 46:21–27. [PubMed: 7623002]
- Hoekstra HE, Hirschmann RJ, Bunday RA, Insel PA, Crossland JP. A single amino acid mutation contributes to adaptive beach mouse color pattern. *Science*. 2006; 313:101–104. [PubMed: 16825572]
- Jasarevic E, Sieli PT, Twellman EE, Welsh THJ, Schachtman TR, Roberts RM, Geary DC, Rosenfeld CS. Disruption of adult expression of sexually selected traits by developmental exposure to bisphenol A. *Proc Natl Acad Sci U S A*. 2011; 108:11715–11720. [PubMed: 21709224]
- Korff S, Stein DJ, Harvey BH. Stereotypic behaviour in the deer mouse: pharmacological validation and relevance for obsessive compulsive disorder. *Prog Neuropsychopharmacol Biol Psychiatry*. 2008; 32:348–355. [PubMed: 17888556]
- Linnen CR, Kingsley EP, Jensen JD, Hoekstra HE. On the origin and spread of an adaptive allele in deer mice. *Science*. 2009; 325:1095–1098. [PubMed: 19713521]
- Loschiavo M, Nguyen QK, Duselis AR, Vrana PB. Mapping and Identification of Candidate Loci Responsible for *Peromyscus* Hybrid Overgrowth. *Mamm Genome*. 2007; 18:75–85. [PubMed: 17242862]
- Magnarelli LA, Anderson JF, Hyland KE, Fish D, Mcaninch JB. Serologic analyses of *Peromyscus leucopus*, a rodent reservoir for *Borrelia burgdorferi*, in Northeastern United States. *J. of Clinical Microbiology*. 1988; 26:1138–1141.
- Maniatis, T.; Fritsch, EF.; Sambrook, J. *Molecular Cloning, A Laboratory Manual*. Cold Spring Harbor: Cold Spring Harbor Laboratory Press; 1982.

- Martin LB, Navara KJ, Weil ZM, Nelson RJ. Immunological memory is compromised by food restriction in deer mice *Peromyscus maniculatus*. *American Journal of Physiology-Regulatory Integrative and Comparative Physiology*. 2007; 292:R316–R320.
- Martin LB, Weil ZM, Nelson RJ. Fever and sickness behaviour vary among congeneric rodents. *Functional Ecology*. 2008a; 22:68–77.
- Martin LB; Navara, KJ.; Bailey, MT.; Hutch, CR.; Powell, ND.; Sheridan, JF.; Nelson, RJ. Food restriction compromises immune memory in deer mice (*Peromyscus maniculatus*) by reducing spleen-derived antibody-producing B cell numbers. *Physiol Biochem Zool*. 2008b; 81:366–372. [PubMed: 18419561]
- McGraw LA, Davis JK, Young LJ, Thomas JW. A genetic linkage map and comparative mapping of the prairie vole (*Microtus ochrogaster*) genome. *BMC Genet*. 2011; 12:60. [PubMed: 21736755]
- Mihola O, Trachtulec Z, Vitek C, Schimenti JC, Forejt J. A mouse speciation gene encodes a meiotic histone H3 methyltransferase. *Science*. 2009; 323:373–375. [PubMed: 19074312]
- Mlynarski EE, Oberfell CJ, Rens W, O'Brien PC, Ramsdell CM, Dewey MJ, O'Neill MJ, O'Neill RJ. *Peromyscus maniculatus*--*Mus musculus* chromosome homology map derived from reciprocal cross species chromosome painting. *Cytogenetic and Genome Research*. 2008; 121:288–292. [PubMed: 18758174]
- Nichol ST, Spiropoulou CF, Morzunov SP, Rollin PE, Ksiazek TG, Feldmann H, Sanchez A, Childs J, Zaki S, Peters CJ. Genetic identification of a hantavirus associated with an outbreak of acute respiratory illness (see comments). *science*. 1993; 262:914–917. [PubMed: 8235615]
- Oliver PI, Goodstadt L, Bayes JJ, Birtle Z, Roach KC, Phadnis N, Beatson SA, Lunter G, Malik HS, Ponting CP. Accelerated evolution of the *Prdm9* speciation gene across diverse metazoan taxa. *PLoS Genet*. 2009; 5:e1000753. [PubMed: 19997497]
- Oriel RC, Wiley CD, Dewey MJ, Vrana PB. Adaptive Genetic Variation, Stress & Glucose Regulation. *Disease Models and Mechanisms*. 2008; 1:255–263. [PubMed: 19093033]
- Pyter LM, Neigh GN, Nelson RJ. Social environment modulates photoperiodic immune and reproductive responses in adult male white-footed mice (*Peromyscus leucopus*). *American Journal of Physiology-Regulatory Integrative and Comparative Physiology*. 2005; 288:R891–R896.
- Pyter LM, Trainor BC, Nelson RJ. Testosterone and photoperiod interact to affect spatial learning and memory in adult male white-footed mice (*Peromyscus leucopus*). *European Journal of Neuroscience*. 2006; 23:3056–3062. [PubMed: 16819995]
- Ramsdell CM, Lewandowski AA, Weston Glenn JL, Vrana PB, O'Neill RJ, Dewey MJ. Comparative genome mapping of the deer mouse (*Peromyscus maniculatus*) reveals greater similarity to rat (*Rattus norvegicus*) than to the lab mouse (*Mus musculus*). *BMC Evolutionary Biology*. 2008; 8:65–78. [PubMed: 18302785]
- Ramsdell CM, Thames EL, Weston JL, Dewey MJ. Development of a deer mouse whole-genome radiation hybrid panel and comparative mapping of *Mus* chromosome 11 loci. *Mammalian Genome*. 2006; 17:37–48. [PubMed: 16416089]
- Sinha AU, Meller J. Cinteny: flexible analysis and visualization of synteny and genome rearrangements in multiple organisms. *BMC Biotechnology*. 2007; 8:9.
- Steiner CC, Weber JN, Hoekstra HE. Adaptive variation in beach mice produced by two interacting pigmentation genes. *PLoS Biol*. 2007; 5:1880–1889.
- Storz JF, Natarajan C, Cheviron ZA, Hoffmann FG, Kelly JK. Altitudinal Variation at Duplicated  $\beta$ -Globin Genes in Deer Mice: Effects of Selection, Recombination, and Gene Conversion. *Genetics*. 2011 [Epub ahead of print].
- Storz JF, Runck AM, Moriyama H, Weber RE, Fago A. Genetic differences in hemoglobin function between highland and lowland deer mice. *J Exp Biol*. 2010; 213:2565–2574. [PubMed: 20639417]
- Storz JF, Runck AM, Sabatino SJ, Kelly JK, Ferrand N, Moriyama H, Weber RE, Fago A. Evolutionary and functional insights into the mechanism underlying high-altitude adaptation of deer mouse hemoglobin. *Proc Natl Acad Sci U S A*. 2009; 106:14450–14455. [PubMed: 19667207]
- Tanimura Y, Yang MC, Ottens AK, Lewis MH. Development and temporal organization of repetitive behavior in an animal model. *Dev Psychobiol*. 2010; 52:813–824. [PubMed: 20607792]

- Trainor BC, Lin S, Finy MS, Rowland MR, Nelson RJ. Photoperiod reverses the effects of estrogens on male aggression via genomic and nongenomic pathways. *Proc Natl Acad Sci U S A*. 2007; 104:9840–9845. [PubMed: 17525148]
- Trainor BC, Takahashi EY, Silva AL, Crean KK, Hostetler C. Sex differences in hormonal responses to social conflict in the monogamous California mouse. *Horm Behav*. 2010; 58:506–512. [PubMed: 20430027]
- Voltura MB, French JBJ. Effects of dietary PCB exposure on reproduction in the white-footed mouse (*Peromyscus leucopus*). *Arch Environ Contam Toxicol*. 2007; 52:264–269. [PubMed: 17160489]
- Vrana PB, Fossella JA, Matteson P, del Rio T, O'Neill MJ, Tilghman SM. Genetic and epigenetic incompatibilities underlie hybrid dysgenesis in *Peromyscus*. *Nature Genetics*. 2000; 25:120–124. [PubMed: 10802670]
- Vrana PB, Guan XJ, Ingram RS, Tilghman SM. Genomic imprinting is disrupted in interspecific *Peromyscus* hybrids. *Nature Genetics*. 1998; 20:362–365. [PubMed: 9843208]
- Vrana PB, Shorter KR, Szalai G, Felder MR, Crossland JP, Veres M, Allen JE, Dewey MJ, Dawson WD. *Peromyscus* (Deer Mice) as Developmental Models. *WIREs Developmental Biology*. 2013 in press.
- Weber JN, Peters MB, Tsyusko OV, Linnen CR, Hagen C, Schable NA, Tuberville TD, McKee AM, Lance SL, Jones KL, Fisher HS, Dewey MJ, Hoekstra HE, Glenn TC. Five Hundred Microsatellite Loci for *Peromyscus*. *Conserv Genet*. 2010; 11:1243–1246. [PubMed: 20563244]
- Weber JN, Peterson BK, Hoekstra HE. Discrete genetic modules are responsible for complex burrow evolution in *Peromyscus* mice. *Nature*. 2013; 493:402–406. [PubMed: 23325221]
- Wu PJ, Greeley EH, Hansen LG, Segre M. Immunological, hematological, and biochemical responses in immature white-footed mice following maternal Aroclor 1254 exposure: A possible bioindicator. *Arch Environ Contam Toxicol*. 1999; 36:469–476. [PubMed: 10227867]

## Appendix 1. Conditions for genotyping markers

Gene	Forward Primer	Reverse Primer	PCR Condition <sup>a</sup>	ENZYME <sup>b</sup>
1700001K19Rik	TGAAGGCATCTGGAGAGAG	TCTTCTGAGTCGCCATCATA	TD65HSP+2.0mM	HpyCH4IV
2610528E23Rik	AGGTGTATCACACGCTTCTC	CAGGTCACAGCAGCATTTA	TD55HSP+0.5XQ	BsmAI
4632411B12Rik	GAAAGATCAGAACCATCACT	GACTTAGGAGAACAGCTTGA	TD55HSP	HpyCH4III
4930538K18Rik	AAAACACAGGAAGCGTAGG	ATGGCAATAGGGACGATGAC	TD65HSP	HphI
5430411K18Rik	GTGGCTGGAACAGGTGTAC	GTCGTTCTGCTCCATCTGA	TD55HSP	MnII
9130404D08Rik	CCTGATCTGGGTCTGAGT	ATTCCAAAGCTCTGAGAAGT	TD55HSP	HpaII
Abcf2	CTGCTCAGTGACACCAAACCT	AACCCAATCCGTGTAAGATC	TD65HS+0.5XQ	2%AG
Abr	CAAGAGAGGTCAGGAATG	GGACTGGAAACGGTACTT	TD55HSP+0.5XQ	AvaII
Acads	GAGCTGGCTGCCTCTGAG	GCTGGTGCCTCGTAGAT	TD65HSP+0.5XQ	PvuII
Acbd3	TGAACTCTTGCTGGGAACCAGGAT	TGCTGAGCTTCATTAGTTGGAGC	60HS+1XQ	SspI
Adam3	ACTGGACATCGTATTTATCT	GGGTCTAATTATTTGTGTA	TD65HSP	SspI
Adams1	AAGAAACCAAAGCATTACAT	AAAGATTCTGCCCAGACTCT	TD55HSP+0.5XQ	MboI
Adck5	GGTATGAGGAGGTGATGTCT	ATCGGCTCATAATCAAACCTC	TD65HS+0.5XQ	MspI
Adra1d	CAACTATTTTCATCGTGAACCTGG	TACACGCGGAGTACATGAC	54HS	BtgI
Afp	CAAGAAGACATCCCAACTAT	GACGTGTTTTTGCACTTCT	TD65HSP+2.0mM	MspI
Allc	TTACTTCTCAGGGAGCTATG	CGCTAATGACTCCAAACCTC	TD55HSP	AluI
Angpt4	GCGACATGGACAATGATAAC	AGTGTGATGGACTGGATAG	TD65HSP+2.0mM	Mwol
Ankrd10	CTCCCAAAGATTCTGAGTCT	TACAGTCTGTTTTCAGGTGAG	TD55HSP	NlaIV
Ankrd5	ACAGAAGAAAAGAAAGTACA	GCAACTGCTATGACTTAGAG	TD65HSP+2.0mM	HaeIII

Gene	Forward Primer	Reverse Primer	PCR Condition <sup>a</sup>	ENZYME <sup>b</sup>
Apip	CATGACAGCAGCCTTAGAG	AAAAAAAAAGCCAGTGTACT	TD55HSP+4mM	StyI
Arvcf	GACAATGAGGTCCGTGAG	ATGGGTACAGCTCTGTAAG	TD65HSP	AvaI
Atp13a3	ATCTACCTTTTGGACAAC	ACAGACCGATGACACTTA	TD55HSP	EcoRI
Atp1a1	TTGCCTCCATTGTGACTG	CACTCTCAGCCTGTTCATAG	TD65HSP+2mM	BsaI
Aup1	GGAGCGGCTCTTTGACTC	GGTGCTACAGTGGTGAG	TD65HSP+0.5XQ	Eco0109I
BC068157	GGAGAGAGAAAGGATTTA	AGTCACAGCCCTTCTCTA	TD55HSP+2.0mM	ScrFI
Bcl2	CACCCCTTCATCCAAGAATG	TACCCGTGTTCTCCCTTG	HS58+1XQ	RsaI,12% AC
Btdb12	CTGATGAAGTGGTCAAGTT	CCGCTCCAGATTCAAGT	TD65HS	MboI
C330027C09Rik	AGTTCCTTTGACAGCGATACT	GATGGTGAAGGATCAGATTA	TD65HSP	HindIII
Cage1	TGGGGATATCTCAAGTCT	AGAATAACAAGTACCGAAGA	TD55HSP+4.0mM	MseI
Canx	TGTGGAATGCAGATGGGTGCTAGA	TGTTTGCTTCAAGGAGAACCCTGC	60HS	BfaI
Car1	CCTGGTCTTGATCTTGAAC	TATTTTGGCTCTCTGACTCA	TD65HS+0.5XQ	SfcI
Ccdc132	GACAGTAAAAACAGAGAAC	GGGATCTCATATCAATAAGA	TD55HS+1XQ	Cell IEXTR <sup>a</sup>
Cd24a	ATGCAAATCAATTCATAAC	GAGAGCAGAATTACGTTGA	TD55HSP+0.5XQ	TaqI
Cdk20	GCCTTTGAGTTCATGTGTC	CAGGCCAAAGTCAGCTATCT	TD65HSP+2.0mM	NlaIII
Chst1	CCATCACAGGACCAGTTA	ACAGCCTCCAGGAACATT	TD55HSP+4mM	MboI
Ckm	AACACCCACAACAAGTTCAAGCTG	GTCTGGATGACATCGTCYASAGTG	TD55HSP+2.0mM	BstUI
Clec14a	ACTGGAAGCAAATAAATAAC	ACATTGGAACAGGAAGATAC	TD55HS+1XQ	NlaIII
Clp1	TCCGAGGCTGCTTCTATC	GGTAGCACAGTGAAGACAT	TD55HSP	AvaII
Clptml1	GAATGTGATGGTGGATGACT	TATGGGGAGGTAGTGTACTG	TD65HS+0.5XQ	PstI
Cnot2	TTATGTGGTCAGAAAATACA	CACAAAAGACTCAACACAAT	TD55HSP	DdeI
Col3a1	GGACCAGGAAGTGATGGGAA	ACTTTCTCCTTGACTTCCCT	60HS	12% AC
Col6a1	ATTGACATCCTCTTCGTGCT	CATCTGGTGTGGCTGTACT	TD65HSP+0.5XQ	BstEII
Col9a1	ATCAGGATTGGCCAAGATGA	GGAATCCTGAAGTCTACATT	53HS+1XQ	RsaI
Cpvl	GGGCCTTATGTTATCACAAG	TAAAGCATGGAAAGGGTAGT	TD55HSP	HpaII
Crem	TTGCAGAGACAGATGATTCT	GAATNCCAGGCNATCAGAG	TD65HSP+2.0mM	RsaI
Csf1r	GGGACAGCACGAGAATATAG	GTAGCAGCAGTATTCAGTGA	TD55HSP+2.0mM	DdeI
Csf3r	CCTTGCCACCAACATCTGG	GCTGGAAGGCTGATGTGAAG	TD55HSP	AvaII
Ddx23	GCCGAACAAGACATCTCAAC	GTTCGCCTCTTTTCCATTAG	TD55HSP	MwoI
Dennd5a	TGTGAAGCACTTCCATAAAC	CACTCTCCACAAAGCAACAG	TD55HSP+2.0mM	AvaI
Dgcr14	GTCGGGAGGGGATGTAGA	GAGGANAGCTGGCGGAAC	TD55HSP+0.5XQ	HinPI
Dnmt3a	TACAACAAGCAGCCATGTACC	TCTCCTGTCACCAAGAAGG	59HS	BstU I
Dnrtip2	AAANTCAGGTGTAATGACAG	CATAGACCTGGACTAAGTA	TD55HSP	AvaII
Dpm1	TACCGAAAAGAAGTTCTAC	TGAAATGAACCGGTAAGT	TD55HSP	EarI
Dzip1	GGGGATAAACAGTTACT	TCCCAGGGTTCAC	TD55HSP	2% AG
Ecd	GGTGATGAAAGAGCACTAGAC	TGGTATCAGAAACAGGAAGTA	TD65HSP+1XQ	DraI
Ednrb	ATGACGCCACCCACTAAGAC	GATGATGCCTAGCACGAACA	62; 2.0mM	Msp I
Efcab10	AGTTATTCTATGTCCATCAT	AAAAAACCCGAGAGAGTAT	TD55HSP	AvaII
Efhb	GCACTCAAAGGTTCTGTTA	TGGAGCTTGAATGAGACTA	TD55HSP	RsaI
Efr3a	ACAGGAAAAGGAAAAGAGAC	CCAATATTTGAGCAAGTCTA	TD55HS+1XQ	MnII
Eil2	AATCCGCCTCAGACTGTA	AGCGCAACCTCTTTAACTC	TD65HSP+2.0mM	BglII;HindIII
Elmod2	GTGAACTGGACAGATGTGTA	CCTGGTAGAGCTGCTTATAG	TD65HSP	RsaI

Gene	Forward Primer	Reverse Primer	PCR Condition <sup>a</sup>	ENZYME <sup>b</sup>
Esx1	GTTTGGTTTCAGAACAGAAGG	GATATTTCCAAATAACCTCCACA	52HS	MboI
Fbxw5	CGGGGATGAGTTCTTAT	TGTAGCTCCAGTTGTATG	TD55HSP+0.5XQ	RsaI
Flt1	CACAAAGATCCCAAAGAGA	AATGAAATGCTGGAGCTGTA	TD60HSP	EarI
Fn1	AGAAGAGAGAGCCCCTGATTG	TGAAGATTGGGGTGTGGAAG	54HSP	NcoI
Frzb	CTATGAAGAyGAGGAACGTTCAG	CACTTCTCAGCTATAGAGCCTTC	52; 2.0mM	MnII
Fyn	TCTTTTTAGTTGAATCAGGT	CAGGTGGAGAGAGGTTACAG	TD55HSP	MnII
Gabarapl1	GAGCTGTAGGGGACCATAC	GGACGCTCTTCATTTGTAGA	TD55HSP	EarI
Gart	CAAGTAATAGCTAAAGGACA	GCTTTAGGACTCCAGGTATT	TD55HSP	HpyCH4V
Gast	CGCCTGCTCTGAAGCTTCTTG	GGCCGAAGTCCATCCATCC	58HS	MseI,BsmAI
Gata6	ATGGGTGTAAGAAGCATGTC	GTGGCAGAACTGTGACAAT	TD55HSP+0.5XQ	Taqal
Gira2	TCAGGAAAATGCTGCCTCGT	ACACACCATCTCCATAAATACTGTAG	59	HpyCH4IV
Glul	AAGCAAGCGGCACCAGTACC	CACGTGCGGATGAGAGCTTCT	TD55HSP	NheI
Golim4	TCCTGGTACTGTTTCATCAAC	ATATAAACCCAGCAGATGAC	TD65HS+0.5XQ	HhaI
Gpi1	GTGTGGACCACCAGACAGG	TTCCGTATGGGGTGTGGGTCT	TD55HSP+2.0mM	AciI
Gpx4	GAATTCTCAGCCAAGGACAT	TTTTCATCCATTCCACAGT	TD55HSP+0.5XQ	BsaI
Gpx5	CTGGAAATTAGGTACGTATC	AGAGCCAGGAGAAAATATAG	TD55HSP	StuI
Gramd3	GGACATTTCTGAGACGTGAC	AAACCACCTCGGACAGA	TD55HSP+2.0mM	HpyCH4V
Grb10	CATGCCAAATGAGAGTAA	GCAGGCACACATACAG	TD55HSP+0.5xQ	2%AG
Grk4	AGACCTAAAGCCAGAGAATA	GCTAGACCAAGATCTGAAAT	TD55HSP+2.0mM	SspI
H19	GCACTAAGTCGTTTGCCTG	CTGTTTCCAGACTAGGCGAG	52	AccI
Hba	CCCACCACCAAGACCTACTT	CGGTATTTGGAGGTCAGCAC	TD65HS	MspI
Heatr1	GGGATTGATGGTCAGATCTA	CATCTAATGTTCTGGGGTAT	TD55HSP+1XQ	MseI
Hmox2	GAAACATTAAGAAGGAGCTA	CTCATTCTGCCCTACATAGT	TD55HS	HinPI
Hps4	ACCCCGATTTTCTGAGT	CAGGGAGGGTTCTGAGAT	TD60HSP+0.5XQ	MboII
Hsbp1	GTGACGGTTCCTAGACAT	GGACATGATCTGAAACTT	TD65HSP+0.5XQ	BfaI
Hsf2bp	GTATGCCTTCATGCCTTG	CCTGGTACTCAAGCACAC	TD65HSP	HaeIII
Hsp90b1	GAATGACATCAAACCAATAT	TCCATATTCATCAAACAGAC	TD55HSP+2.5mM	EcoRI
Igfbp1	TTTTACTTGCCAAACTGCAAC	GGTAGACGCACCAGCAGAG	TD55HSP	PvuII
Il23a	AGCCAGATCTGAGAAGCAGG	CTGCTCCTGGGCAAAGACC	HS66	MspI
Impact (#1)	TGGGTGAAAATATGGGCATT	AGGGCATGGACCACAGATAG	49; 2.0mM	BfaI
Impact (#2)	CTGGTATGGAGGGATTCTGC	GCCCATATTTTACCCAGTC	49; 2.0mM	BssSI
Inha	TCAGCTCAGCTGTGGTTCC	CTCGTACTTGAAAGAGTAACCTCCA	TD55HSP	BssHII
Inpp4a	CAGCAGCTTCACAACTG	CGTTGACGAGAGCTTGAC	TD65HSP+0.5XQ	DdeI
Irs4	TAGGCTTGCTCCCGCTGGA	RAGCCCCGGCCATTTCCTGAGC	64HS	BmeI580I
Isg20l2	TTTCATCCCAAGTCTCTCAC	GCTAATTTTCTGGAGGATTC	TD65HSP	PstI
Itm2b	AGAAACCTGTTGGAGCTACT	GCTCATGGAGGAGGTAAG	TD65HSP+2.0mM	BamHI
Iws1	TTGACAGTGGCGTGAT	ATTAATTTCCCTGCCATATC	TD55HSP	MboI
Katnb1	AGGATGCCATGTACAGATA	TTGCAGGAGTTTCTCAATCT	TD55HSP+0.5XQ	MspI
Lit1	ATGTTGGAGGGAGGGGTATC	CCTTTCACAGGGGTACCTA	TD55HSP+0.5xQ	HpyCH4III
Krt17	GGAAGCCGACATCAATGG	TTCTTCAGGTAGGCCAGCTC	52HS	MboI
Lama1	GAGGGGTTGCATCA	CCACAGGGTACAGTTAC	HS59-64	2%AG
Lep	GACCTTAGCCCTGAATGCTG	TGCTTTGCTTCATATCCATCC	52	BsrBI

Gene	Forward Primer	Reverse Primer	PCR Condition <sup>a</sup>	ENZYME <sup>b</sup>
Lrch4	ACCGAAGTCCAGTGCTAC	ACAACGGACTCTGGAGAG	TD65HSP	BccI
Ltp1	TAACACAGAGGGCTTTACA	CCAGAGGACGGCTACA	TD55HSP	2%AG
M33	GCTCCCGTGCATTTCTTTAC	AGACAAGAGCAGTCATTTCTGCACC	52	length
Maoa	ATCAAGTGCATGGTGTATTACA	ATCTTCAATCATCATGCA	52	BstNI
Mapkapk5	AGGAACTGGACACTGTTAG	AAGAACGGTTTGCCTGA	TD55HSP	BsrI
Mas1	GTGCACTGGGTCATYATGAGCAT	GCATTTTCATCTTTGAAAGCCCTGGT	62HSP	AvaII
Mdm1	AAGTCCAAGGCAGACAGA	TTGTCTCAGCTTCGGAGTAG	TD65HSP	HinFI
Mlst8	GGGCGGTAGCAGATGTAG	AGGCCCCACTGACAGTAAT	TD65HS	HphI
Mmel1	CTTCAGAACATGGACAAATC	CGGTCTTTGACATCGGAATC	TD65HS+0.5XQ	HindIII
Mpo	CCACACCCTCATCCAACC	GTCCCCGGATCTCATCC	TD55HSP+2.0mM	PvuII
Mtus1	GTAGATTCTCAAGCGACTTC	GCCCATGAAACCACTAA	TD65HSP	HaeIII
Mtx2	TCTCTGAGAAAGGGCTTGA	GATGGGGGAACAAGACTCT	TD55HSP	BglII
Mut	TACTGTGGAAGAAAGCAATA	AGGGTTGTCTGAATCATAAC	TD55HS+1XQ	RsaI
Myl4	AAGGAGCAGGGCACCTATG	GATGCAGCCATTGGCATC	60HS	NheI
Nap115	GCAGGATCTCTCTGGACCAGCTC	CCGTGTAGCTCCTGGATCTTGGC	62	BtsI
Nck1	AGTATCACTAAAAGCACAAG	TNTCATAACAGTACCAACAG	TD55HSP/4.0mM	MboI
Oprk1	CCTGGCTTTGCRGATGCTTTRGT	TTCCCTGACTTTGGTGCCTCCAAG	60HS	RsaI
Otc	ATGCTATGGCTATCAGCAGATCTGAA	AGACAATCTTGTTGAGTACTTCT	55	Fnu4HI
Pacrg	GAGGAAGAGCTGTACAAGTC	GACTACAGCCAGCAGAAGAG	TD65HSP+0.5XQ	Fnu4HI
Pacs2	CACAATTCCAACCTTCACA	GGTTCATTCCTTTGTGG	TD55HSP	AvaII
Pam	CATTCAGATTCGAAAAATAGT	GAATCGGAGGAGGAGGAGTACT	TD55HSP+0.5XQ	HinFI
Penx	AGATTCTGGAAGGGATTAAC	TGACAGTCACGTATTTATCA	TD55HS+1XQ	MboI
Pdcl2	TAAGAGATTTTGGCATTTC	TCATCTTCTCATAACGGTTTA	TD55HS+2.0mM	NlaIII
Pde9a	CTTCCAGTACCTGCTCTC	GGCTCTGTCTCTTGTGTC	TD65HSP+2.0mM	pFLMI
Peg3	CTGGGTCAGCCATTCGATG	GCTCTGCAGCCTCCACTTC	TD55HSP+2.0mM	MspI
Peg10	TGGTCAGTAGACGCATGAGC	CGCATGAAGCGCTGGATCTTGGC	59+2.0mM	HpyCH4III
Phf1	GCTCTGTGTTGTGTCTGTC	AGTCCATACGGCAGAGAGAG	TD65HSP	PstI
Piwil1	GCATCGACTGTTACCATGAC	TCCACGGTCTGAAAGAC	TD55HSP+0.5XQ	HpaI
Pkhd111	CAATTCCATTAGCAACTGT	CTGAAGGCTCTCGATTCT	TD65HSP+2.0mM	MnII
Plag1	GTTCAACCGCAAGGACCAC	TCTTGGTGTGACGAGTGAGG	54HSP+2.0mM	DdeI
Plekha5	CCATCCCAGGATAATTGTAT	GGTCGCTCCTTCTTTTCTTC	TD55HSP	BfaI
Plp1	GGTCCAGAGAGAATTAGGCTAGA	GTACACAGGCGCAGCAGAGCA	58HS	MseI
Pmfbp1	AGGATGAAAAAGCTCAACAT	CAGCATCTTGAGGTCCTCT	TD55HSP	BsrI
Pofut2	GGAGTCCACCTGAGAAGA	AAAAAACCTGGCATGAG	TD55HSP+2.0mM	RsaI
Ppp1cb	GGAACAGATTTCGGAGAA	AGCTCGACAAATCAAGTCTA	TD55HSP	PmlI
Ppp1r9b(#1)	GTCCGAGARAGAAGCAGAC	CGGAAGAACTTCCTGTACTG	62; 2.0mM	BclI
Ppp1r9b(#2)	GGA CCC CCT GGT CAAACG	GAC CCA ACC CTC TCCCGY GA	62; 2.0mM	MseI
Prdm9	CAAAGAACAATGAGATCTGA	GTCTTYCTGTAATTGTTGAGATG	TD55HSP+0.5xQ	length
Prdx4	TTYGCGCTYGCKTGGTCATGGA	TCTTSGCTTTGCTTAGRTGCAG	52HS	Fnu4HI
Prdx5	GGATGATTCTTTGGTGTCTC	GGCAGACACAAATCAAGACT	TD65HS+0.5XQ	HpyCH4IV
Preb	ACCACTGCTACCTGAGTCTT	CTCTGTGCGCATCTACATAG	TD65HS+0.5XQ	DdeI
Prkcd	GGATGTGCAAAGAGAATATA	ATCCTGATGTTTCTGTTCAT	TD65HSP+2.0mM	DdeI

Gene	Forward Primer	Reverse Primer	PCR Condition <sup>a</sup>	ENZYME <sup>b</sup>
Prpf19	GTCTACCAAGGAAGTCACT	AGCCTGTGGTTTCAGAGTAG	TD65HS+0.5XQ	BsmAI
Prss37	GAAATCTCAAAAGCAGAATC	CAGTCTTTGTCAGTCATCAC	TD55HS+1XQ	MboII
Ptpn13	TTTTTCTTCTCTTTCCTCTG	AGTCCTCAAAGAGCAAATCT	TD65HSP+2.0mM	SmlI
Pygl	AAGAAAACCTTCGCCTATAC	ATCTTTGCTACCCCAATTCAC	TD55HS+1XQ	NheI
GM9999	GGC CTT CCA ATA ACCAC	CTGTGCAGTTGGGTGATCTT	TD65HSP	RsaI
Rbm5	CTTCAACCTTTTTTTTAAAT	GTTGATGAAGAGGAAAACAG	TD55HSP+0.5XQ	AflIII
Rnf20	TTCATACTCTTTCGCGACCT	GAGGAAGTGGTTAAGGAGAC	TD65HS+0.5XQ	SacI
Rnf214	AGCCTTCCTCAGATCCCTAC	AAAAGACAAAGAGCGAGGAT	TD55HSP	MboI
Rnf44	ACATGATGCCACGAAGAC	GTTAGCCTTCAGCCACTT	TD65HSP+2.0mM	MseI
Scal	GCCTGAGTTGGTTGTTA	CAGTATTAAGCGATGAGTA	TD55HSP	BsrI
Sec61a2	TAAGACATGGATAGAAGTGT	AATTTTAGTTCTCTTGTGAA	50HSP	Cell IEXTR
Sec62	TAAAAGCCTGTTGCAGTAGT	GGTCATCGGGTTGATTAT	TD55HSP+2.0mM	MseI
Serinc1	TGTTCTACCTTCTCCTCTCT	AAGAAAGCTCCAACAATAAT	TD65HSP+2.0mM	TaqI
Sh3gl3	CGCGTTCACAGGCTTTAACT	TAGAGGCAGCATTGGACTAT	TD55HSP+0.5xQ	Cac8I
Siah2	AATTTCTACATGCTGTCAGT	ATGTGTAACAGGTCATCAC	TD55HSP+2.0mM	AvaI
Sik1	GTTCCGCATCCCCTTCTT	CAAGGGCCTGCATGATAC	TD55HSP+0.5XQ	PstI
Sos1	ATTCCAGAGCCTGAGCCAACAGA	CTCTTACTGTTCCAATAAATTCYTCCA	62HS	MspI
Spag6	AAGCAGAGATTTTCCAGTT	CCTCCTGCGTTAACAATCAG	TD65+2.0mM	HphI
Spam1	CCCAATTTTAAAGTCTCTTC	GCCTGTCACAATATTTTACA	TD55HSP	SfaNI
Sparc	CCCCAATGTTTAAAATGTTTGG	TTTCGTGTGCTGTTACTTCCCT	TD55HSP+2.0mM	HhaI
Spata21	CTCCAAGACCCGAGAGAC	GATCAGCACAGGATGGTATG	TD55HSP+2.0mM	MslII
Spata4	TCTGTGAAATGGGGTAGT	TTAAAAGTCAAGCTGGATAAC	TD55HSP+2.0mM	DdeI
Spsb3	CAAGTCTGCATAACAAG	ACCCACTGACATCATGTA	TD65HSP	BsmAI
Spz1	TAGGTCGTCTGAGATGTCAC	AAGGGGNCAGTGATCCNATT	TD65HS+0.5XQ	Cell IEXTR
Sri	TGGAGACTTGTGCCTTAT	TTCCACTCCTATCGCTGTC	TD55HSP	EarI
Srpk2	GCATTCTGGGGAAGACTA	ATTGAAGAATCCCGAGAA	TD55HS+2.5mM	Cell IEXTR
Sstr2	CTCACCATCATCTGTCTTTGCTAC	TGGAGGTCTCCATTGAGGAG	TD55HSP	HhaI
Stk11	GTGCTGTACAATGAGGAGAA	CTCAAGCAGAACTCCATCAC	TD55HS+1XQ	Cac8I
Tbc1d21	CATGGGAACTTCACAGAGAC	CAGGGGATCTTTGTCATATA	TD55HSP	StyI
Tcp10b	AAAAATTCTACCCGGATGGC	GATGGTTTTGTCTCCGTTCC	62hSP+0.2mM	2%AG
Thbs1	CTTTCACTTTGGGGCTTAGA	TCTCTATTCCAATGGCAATG	TD55HSP	NlaIII
Tmem111	CTCCTGTCATCTGCTCCT	ATCCTGGTACTTCTCAA	TD55HSP+0.5XQ	2%AG
Tmem67	CGCCTGTTCCATTATATC	GCTGTAAAACACCACCTTCT	TD55HSP	HpaI
Tpr	AGATCAAATGGAAAAAGAAA	TCCACTCCTTTTCTATCTCA	TD55HSP+2.0mM	RsaI
Tram1	AATGGAGCGGTCACATC	TTCTGATGCCAGTTGA	TD55HS+0.5XQ	BglII
Tyk2	CAGAGGCAAGTGAATCTC	AGAGTCTTCCAGCGATTC	TD65HSP+0.5XQ	Fnu4HI
Ube2j1	TAATGGACGATTTGAAGTAG	GCTCCCTCTCCTTTAGTT	TD55HSP+0.5XQ	2%AG
Ube2k	TAAGAGATTTTGGCATT	TCATCTTCTCATACGGTTTA	TD65HS	AleI
Ube3a	GCATAGTCTCCTGGTCTG	ATCATACATCATTGGGTTAC	TD55HSP+2.0mM	BsaHI
Ubxn11	GTGGAAAGGTGCTGAAGATC	GGAGATCATAGTGAGACAC	TD65HS+0.5XQ	StyI
Ugp2	TAACTCTGGCTGCTCGACACCTT	TCCACCAGTCTCAGTTGCCTTCA	60HS+2.0mM	AvaII
Usp20	TCTCGATGGGTTGGTTGT	CATGGTAGCCGCTGTG	TD55HSP	DdeI

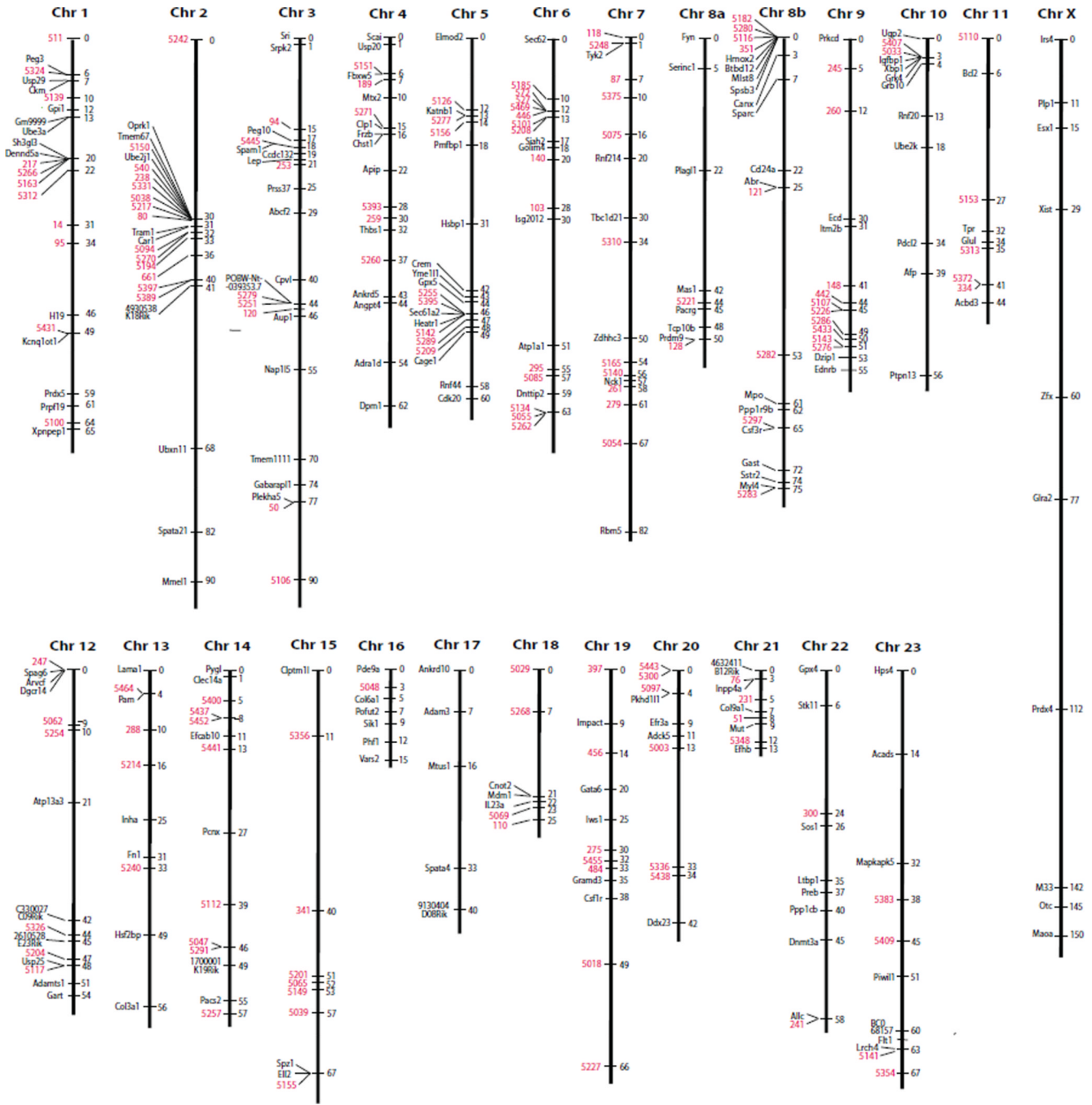


Gene	Forward Primer	Reverse Primer	PCR Condition <sup>a</sup>	ENZYME <sup>b</sup>
Usp25	CCTCTCCAGACTCAAACATC	TTCCTTATCTGTGCTTATCA	TD55HSP+4.0mM	2% AG
Usp29	TAGCTTAGTGCTTTGGTGTTC	AGGGAGTTGACGTCAACGGAGT	52HSP	HphI
Vars2	GGATGCACATCATGAAGA	CTACAGCCCGCAGTATGT	TD65HSP	StyI
Xbp1	TGGCCTTGTGATTGAGAACCAGGA	ACAGCGTCAGAATCCATGGGAAGA	TD65HSP	HindIII
Xist	CTCCCCCTTTAAGAGGGAACTTGA	TACCCGGAAGTGACCACAAT	55	BstNI
Xpnpep1	TGGATTTCGATGGCTCTG	ATGCTCTCCGTGATGAT	TD55HSP	BfaI
Yme111	ANATAACACAAGGAGCATTT	ATCAGAATTCGATGAGATGT	TD55HSP	MboII
Zdhc3	AACAACGTGTTCGGCNANAA	CAAGGAAATGAGAGCTATGT	TD55HSP	AvaI
Zfx	GCTCCGCAAGCTCTCAGGAAGT	AAGGAAAGGAGCATAAGTGATC	52	HaeII

<sup>a</sup> mM, concentration of magnesium chloride

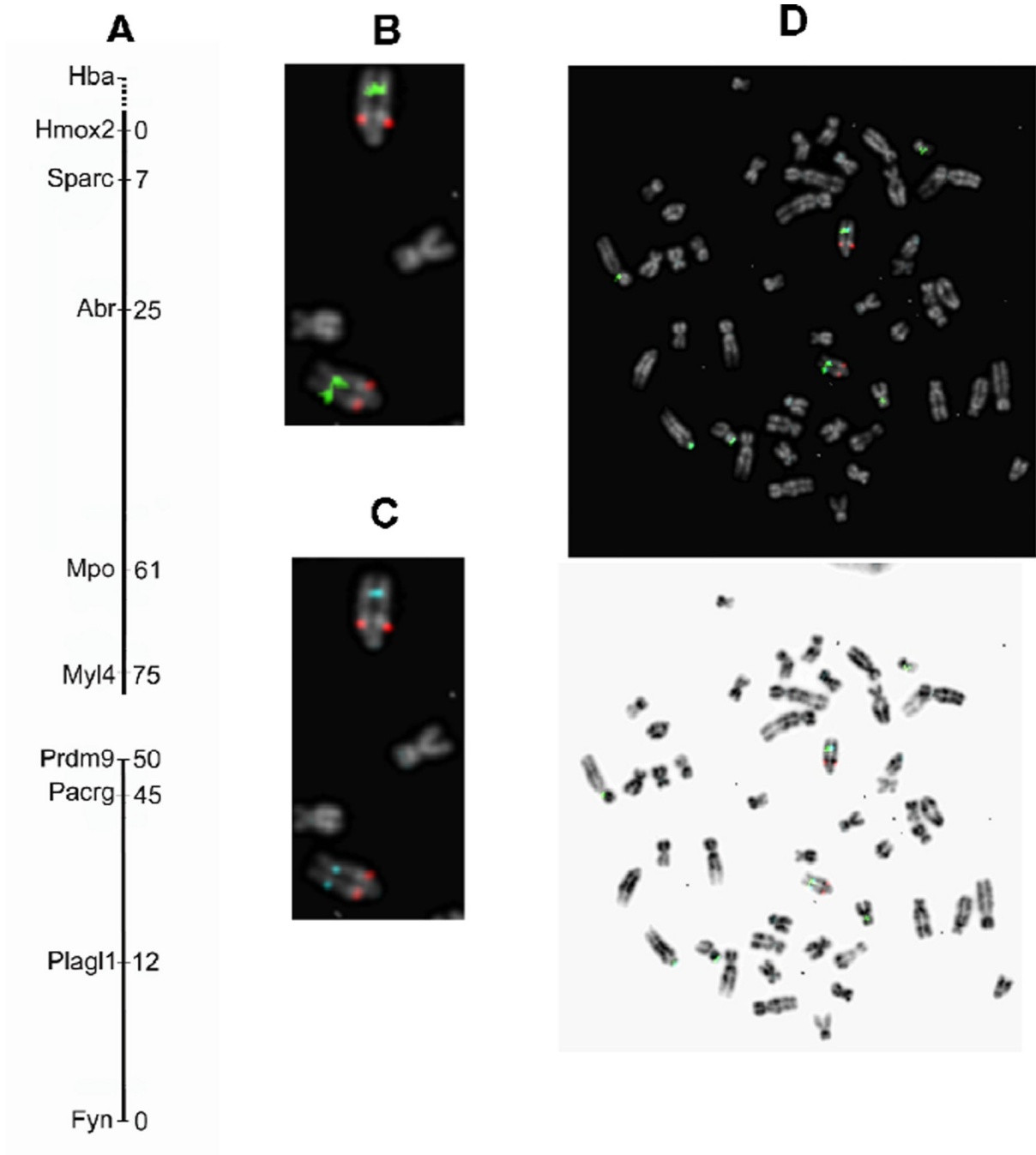
<sup>b</sup> CEL EXTR, Pimpkin M, Caretti E, Canutescu A, Yeung JB, Cohn H, Chen Y, Oleykowski C, Bellacosa, and Yeung AR. 2007. Recombinant nucleases CEL I from celery and SP I from spinach for mutation detection. BMC Biotechnology 7, 29.

AG, agarose; AC polyacrylamide

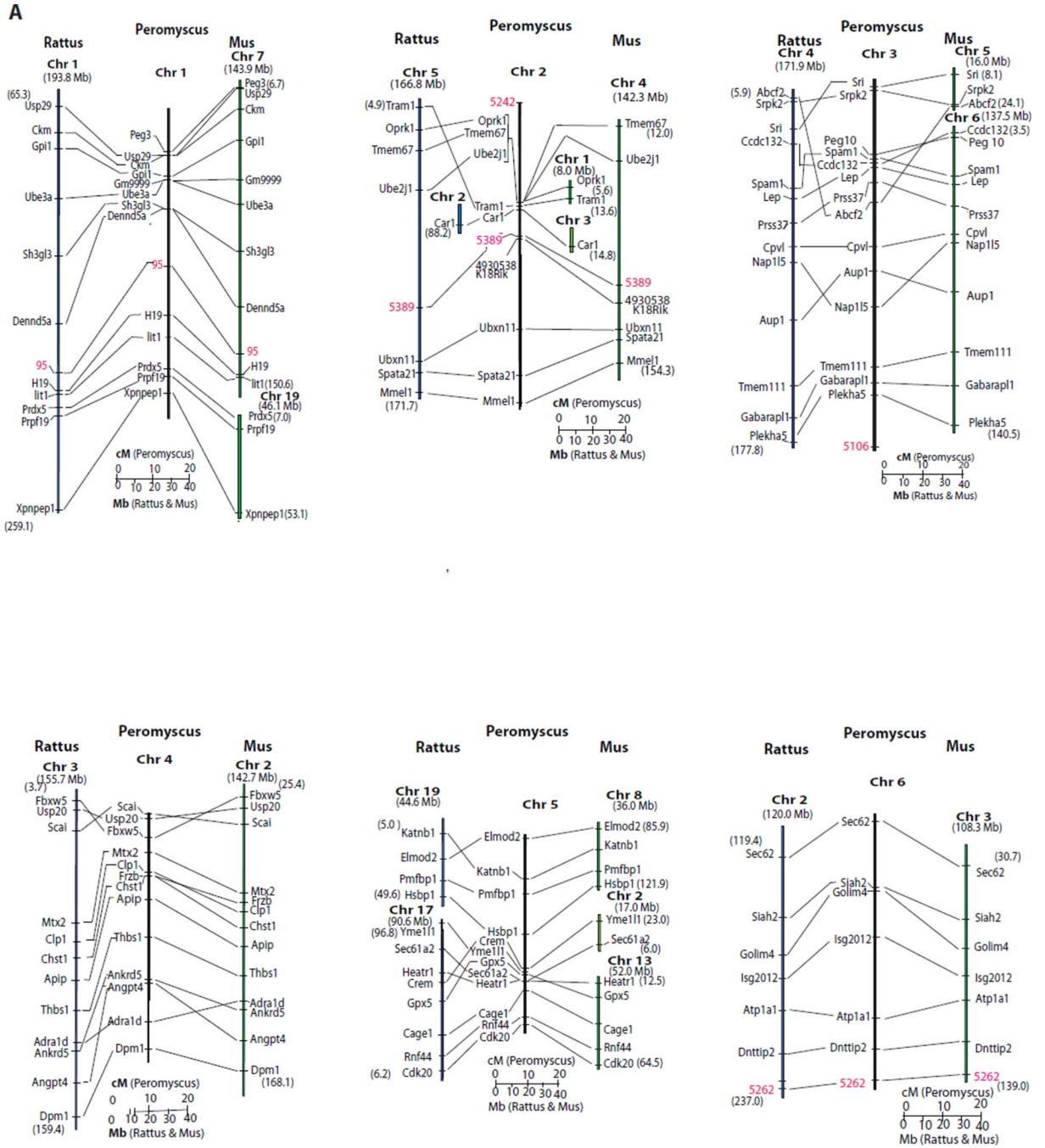


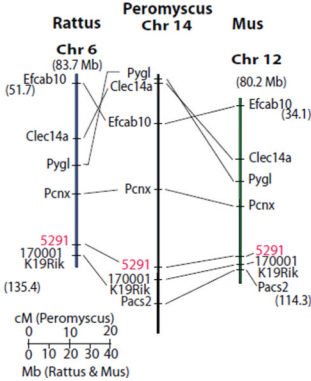
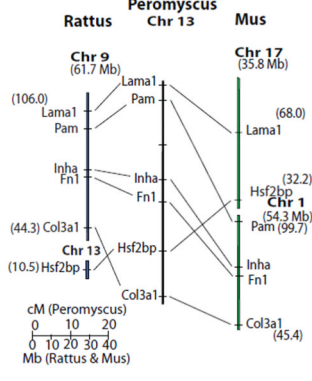
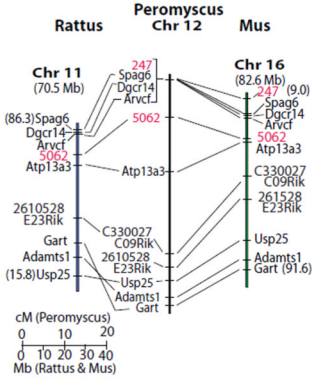
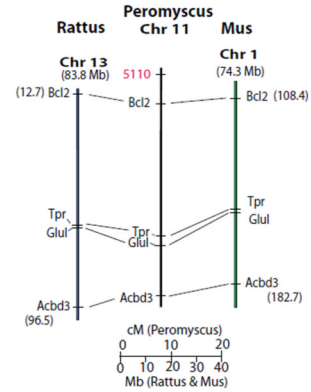
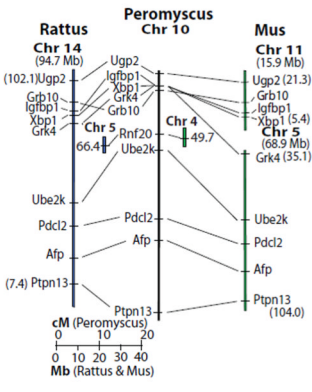
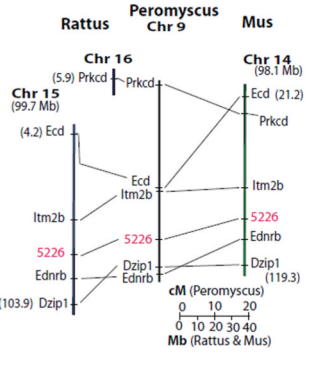
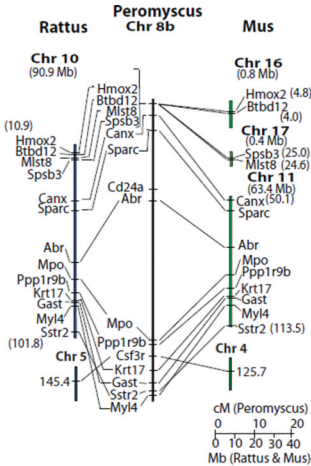
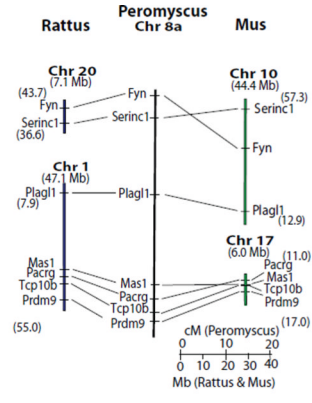
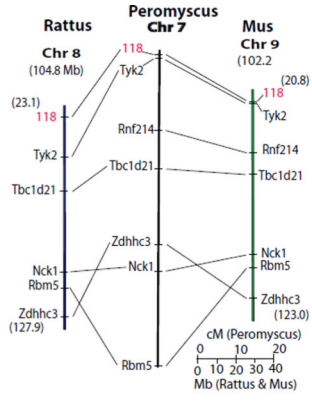
**Figure 1. *Peromyscus* genetic linkage map**

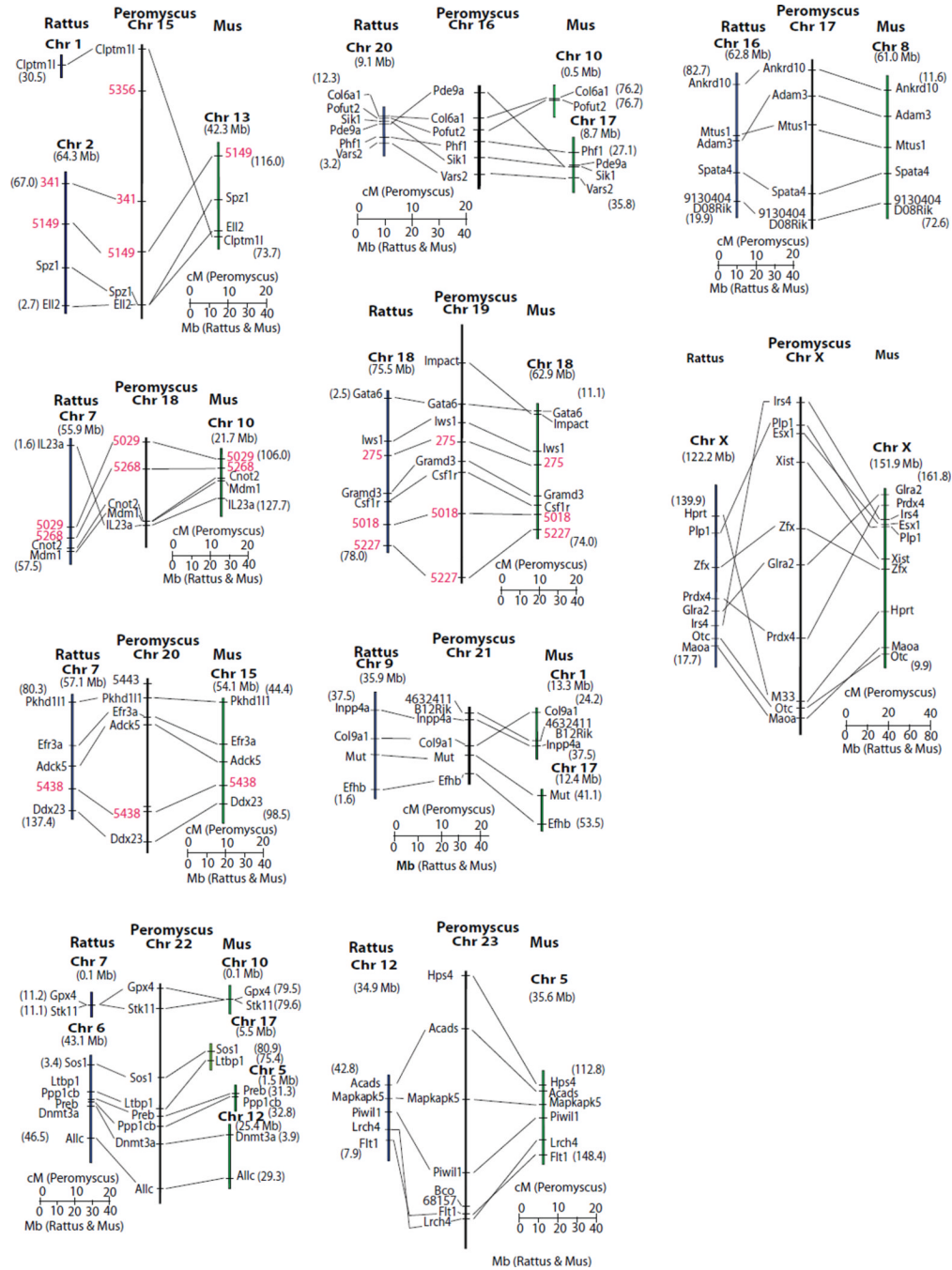
Type I genetic markers are shown in black and microsatellite loci are indicated in red. The linkage groups are associated with the *Peromyscus* chromosomes according to the standardized nomenclature of the karyotype. Two linkage groups are assigned to chromosome 8.



**Figure 2. Linkage groups 8a and 8b are both located on *Peromyscus* Chromosome 8**  
 (A). The two linkage groups are aligned according to their location on Chromosome 8. BAC clones containing different genes were fluorescently labeled as described in Materials and Methods. (B). FISH to *Peromyscus* metaphase chromosomes with BACs harboring the *Hba* (red) and the *Pacrg* (green) genes. (C). Results of hybridization with BACs harboring the *Hba* (red) and *Mpo* (aqua) genes. (D). Merged hybridization results showing that the *Pacrg* and *Mpo* genes are close together while *Hba* is more proximal to the centromere of Chromosome 8.



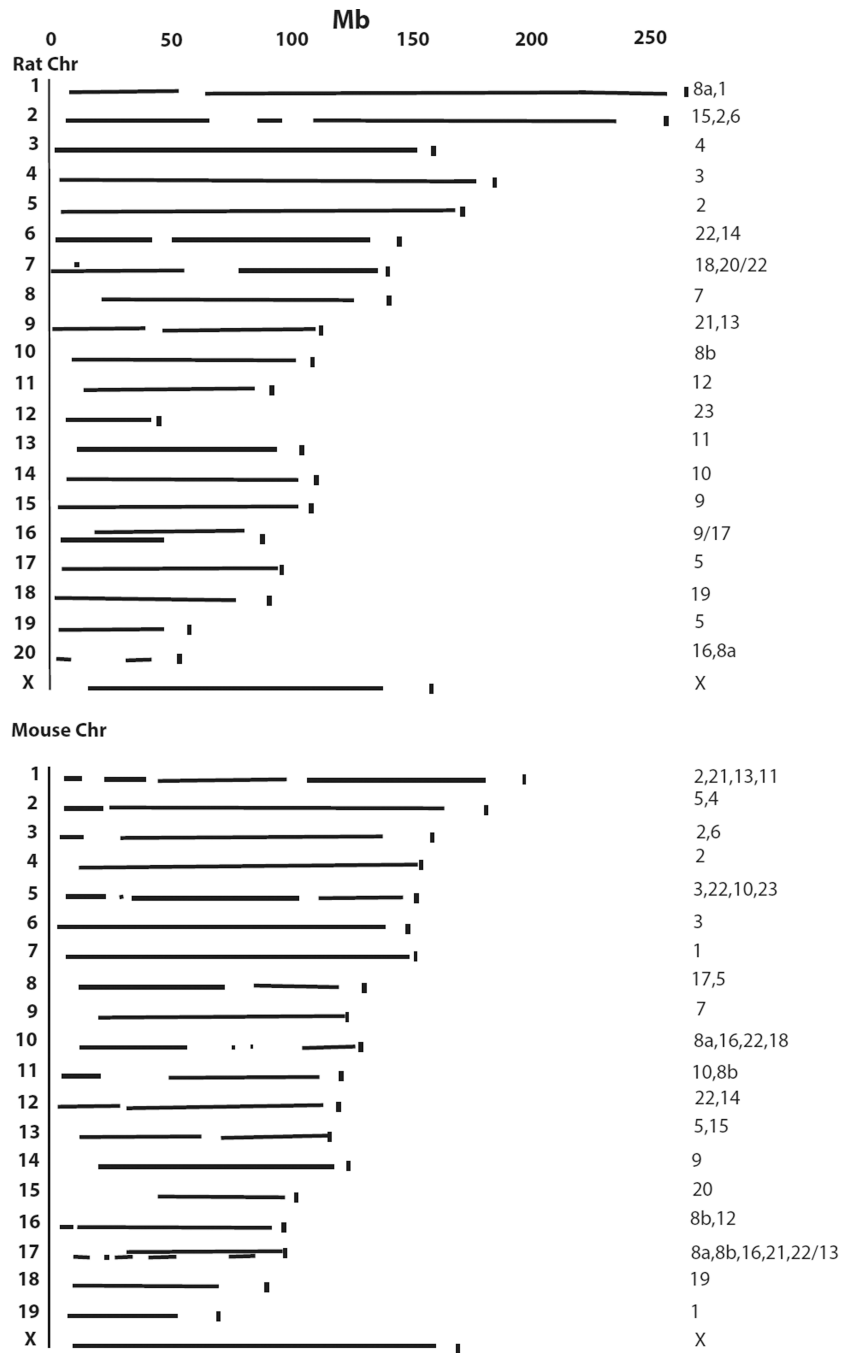




**Figure 3. Comparative relationships of the genetic map of *Peromyscus* with the molecular map of *Rattus* and *Mus***

For *Rattus* and *Mus* segments the numbers in parentheses indicate the molecular position at the ends of the chromosomal segment. The *Rattus* and *Mus* chromosomes are indicated in bold. Molecular locations of *Mus* loci come from Genome Reference Consortium Mouse Build 38 (GRCm38) and *Rattus* gene positions are from RGSC Genome Assembly v3.4. Fig. 3A. *Peromyscus* chromosomes 1-6 compared to *Mus* and *Rattus*. Fig. 3B. *Peromyscus* chromosomes 7-14 compared to *Mus* and *Rattus*. Fig. 3C. *Peromyscus* chromosomes 14-23 and the X compared to *Mus* and *Rattus*. The M33 locus (Vrana et al. 2000) on the

*Peromyscus* X chromosome is not orthologous to *Hprt* but its sequence is found very near this gene in both *Mus* and *Rattus*.



**Figure 4. Coverage of the *Peromyscus* genetic map revealed by comparison to the *Rattus* and *Mus* genomes**

The length of the corresponding *Peromyscus* mapped segments containing homologous *Mus* or *Rattus* chromosomes are indicated. The vertical mark at the end of each chromosome indicates the full length of the *Rattus* or *Mus* chromosome. The numbers at the end of the linkage segments are the *Peromyscus* chromosomal linkage group segments in order corresponding to the *Rattus* or *Mus* chromosomes. In cases of overlap of corresponding *Peromyscus* linkage segments (*Rattus* 7, 16 and *Mus* 17) the number(s) before the slash represent segment(s) on the bottom and those after the slash represent the segment(s) on the top.



**Table 1**Synteny Conservation between the *Peromyscus* Genetic Map and *Rattus* and *Mus* Genomes.

Segments	Total Length <sup>1</sup>	Rattus		Mus		
		Number	Average Length	Total Length	Number	Average Length
Syntenic-1 <sup>2</sup>	727.2	11	66.1	698.1	18	38.8
Syntenic-2 <sup>3</sup>	980.1	13	75.4	687.5	16	43
Syntenic-3 <sup>4</sup>	540.4	4	135.1	687.9	6	114.7
Total	2247.7			2073.5		
Genome Size	2719			2639		
Coverage (%)	82.6			78.5		

<sup>1</sup> Length is in Mb

<sup>2</sup> Syntenic-1 is the length of all segments of the molecular maps of *Rattus* or *Mus* having genes in the same order as the *Peromyscus* genetic map.

<sup>3</sup> Syntenic-2 is the molecular length of segments in the *Rattus* or *Mus* genome having synteny conservation with the *Peromyscus* genetic map but gene order is altered by one inversion and/or insertion.

<sup>4</sup> Syntenic-3 is the length of syntenic segments conserved but with gene order differing from the *Peromyscus* genetic map by two or more inversions and/or insertions.