

Intradimerically tethered DNA topoisomerase II is catalytically active in DNA transport

(leucine zipper/cross-linking/DNA gyrase)

JANET E. LINDSLEY

Department of Biochemistry, University of Utah School of Medicine, 50 North Medical Drive, Salt Lake City, UT 84132

Communicated by Nicholas R. Cozzarelli, University of California, Berkeley, CA, December 18, 1995 (received for review August 14, 1995)

ABSTRACT A covalently cross-linked dimer of yeast DNA topoisomerase II was created by fusing the enzyme with the GCN4 leucine zipper followed by two glycines and a cysteine. Upon oxidation of the chimeric protein, a disulfide bond forms between the two carboxyl termini, covalently and intradimerically cross-linking the two protomers. In addition, all nine of the cysteines naturally occurring in topoisomerase II have been changed to alanines in this construct. This cross-linked, cysteine-less topoisomerase II is catalytically active in DNA duplex passage as indicated by ATP-dependent DNA supercoil relaxation and kinetoplast DNA decatenation assays. However, these experiments do not directly distinguish between a “one-gate” and a “two-gate” mechanism for the enzyme.

Type II DNA topoisomerases are ubiquitous enzymes that catalyze the ATP-dependent transport of one segment of duplex DNA through an enzyme-mediated transient break in a second DNA duplex (1–4). These enzymes participate in many DNA metabolic pathways, including the segregation of newly replicated DNA molecules (5, 6) and the condensation of chromosomes in mitosis and meiosis (7, 8). They are also the targets of a diverse group of antibiotics and anticancer agents (9, 10).

Type II DNA topoisomerases from organisms as diverse as bacteriophages, prokaryotes, and eukaryotes are structurally and mechanistically related (11, 12). They are all dyadic, existing in their active conformations as homodimers, A₂B₂ tetramers, or A₂B₂C₂ hexamers. Each identical half possesses two distinct catalytic active sites: one for ATP binding and hydrolysis and the second for DNA cleavage and religation. The latter functions by forming a transient covalent intermediate consisting of an active-site tyrosine and a 5' phosphoryl end of the severed DNA.

Purified topoisomerase II from the budding yeast *Saccharomyces cerevisiae* has been used to study how the ATPase and DNA cleavage/religation active sites from the two halves of the homodimer coordinate their activities to catalyze the transport of one DNA duplex through another. The enzyme can hydrolyze ATP in the absence of DNA, and cleave/religate DNA in the absence of ATP (13, 14). However, the rate of ATP hydrolysis is stimulated 20-fold by DNA, the DNA cleavage/religation equilibrium is perturbed by the presence of ATP and, most importantly, the passage of one DNA through a transient break in another only occurs in the presence of ATP (15, 16). When the topoisomerase binds ATP, it undergoes a major conformational change such that the enzyme topologically clamps down around DNA (17). By studying a preparation of topoisomerase II in which one subunit was immunotagged and defective in ATP binding and the other was wild type, it was shown that ATP binding to one protomer can induce a concerted conformational change in the entire enzyme (18).

Two general mechanisms, often termed the “one-gate” and “two-gate” models, have been proposed for the functioning of topoisomerase II (3, 19–22). It is proposed in the one-gate model that all DNA substrates and products enter and exit from the same face of the enzyme. In the two-gate model, the transported duplex enters one face of the enzyme, is passed through the cleaved DNA duplex, and exits from the opposite face. Results of an elegant, although indirect, experiment by Roca and Wang (20) support a two-gate mechanism.

To further understand the interactions between the two halves of topoisomerase II we designed a derivative of the yeast enzyme in which the two protomers of the dimer can be efficiently and covalently tethered. In addition, all of the cysteines in this topoisomerase II derivative have been changed to alanines. As described in this communication, purified type II DNA topoisomerase does not require any of its cysteines for activity, and it remains catalytically active when its carboxyl termini are covalently linked.

MATERIALS AND METHODS

Materials. Standard reagents were purchased from commercial sources as described below: ATP, Pharmacia; dithiothreitol, Boehringer Mannheim; leupeptin, pepstatin, benzamide, and diamide, Sigma; pBluescript, Stratagene; goat anti-mouse and goat anti-rabbit IgG-horseradish peroxidase conjugates and SDS/PAGE molecular-weight standards, Bio-Rad. *S. cerevisiae* DNA topoisomerase II rabbit polyclonal antibodies and anti-Ha mouse monoclonal antibodies (12CA5) were from James C. Wang (Harvard University). Kinetoplast DNA was purified from *Crithidia fasciculata* as described (23). DNA oligonucleotides used for construction of topoisomerase expression vectors, site-directed mutagenesis, and sequencing were made at the DNA Peptide Synthesis Facility, Huntsman Cancer Institute, University of Utah (National Institutes of Health grant CA 42014).

Construction of Expression Vectors. All vectors used for the expression of altered *S. cerevisiae* DNA topoisomerase II are derivatives of the plasmid YEptTOP2-PGAL1 (24). The codons for all nine of the naturally occurring cysteines were mutated to alanine codons by oligonucleotide-directed mutagenesis using the Altered Sites II kit (Promega); construction of this plasmid (pDAT10) will be described in detail elsewhere. Derivatives of pDAT10 in which the last 95 codons of the *TOP2* gene were replaced with codons for either the Ha epitope from the influenza hemagglutinin protein (25) (pJEL205) or the yeast GCN4 leucine zipper (26) (pJEL203), were constructed by standard recombinant DNA methodology. The exact peptide sequences following Ala-1334 of topoisomerase II for the expressed proteins are as follows: Ala-Arg-Gly-Tyr-Pro-Tyr-Asp-Val-Pro-Asp-Tyr-Ala for topoII(C→A)Ha, and Ala-Arg-Gly-Gly-Gly-Arg-Met-Lys-Gln-Leu-Glu-Asp-Lys-Val-Glu-Glu-Leu-Leu-Ser-Lys-Asn-Tyr-His-Leu-Glu-Asn-Glu-Val-Ala-Arg-Leu-Lys-Lys-Leu-Val-Gly-Glu

Arg-Gly-Gly-Cys for topoII(C→A)zipGGC; the boldface letters represent the amino acids making up the Ha epitope and the GCN4 leucine zipper, respectively.

Expression, Purification, and Oxidative Cross-Linking of Proteins. The vectors pJEL203 and pJEL205 were transformed into the protease-deficient yeast strain BCY123 (27) and expressed as described (24). Using these expression conditions, <1% of the topoisomerase II purified comes from the chromosomal copy of the wild-type *TOP2* gene; the remainder of protein is from the plasmid-borne gene (16, 27). The topoisomerase derivatives were purified as described (24), except that: (i) the yeast cells were cracked in the presence of leupeptin and pepstatin at 1 μ g/ml, 10 mM dithiothreitol, 1 mM benzamidine and the tubes of cells were first flushed with nitrogen gas, and (ii) all buffers were thoroughly degassed and, except for the final dialysis buffer, contained 3 mM dithiothreitol. The purified protein (1 ml) was dialyzed against 2 liters of dialysis buffer (50 mM Tris·HCl, pH 8.0/200 mM NaCl/10% glycerol) by stirring on ice in a nitrogen-filled glove bag. Tubes containing aliquots of the protein were flushed with nitrogen gas before storage at -70°C . Protein concentrations were determined with Coomassie Plus protein assay reagent (Bio-Rad) and are reported as dimer concentrations. Oxidative cross-linking of topoII(C→A)zipGGC by disulfide bond formation between the terminal cysteines was induced by the addition of diamide (1 mM final) (28).

Topoisomerase Activity Assays. Topoisomerase II derivatives were diluted to twice their final reaction concentration in dialysis buffer. An equal volume of 100 nM pBluescript KS⁺ (plasmid concentration) or kinetoplast DNA at 66 μ g/ml in reaction buffer [50 mM TrisOAc, pH 7.5/120 mM KOAc/15 mM Mg(OAc)₂ and 250 μ g/ml bovine serum albumin] was added to the diluted protein, and the mixture was put at 30°C . After a 5-min incubation, an aliquot was removed to a separate tube to be the $-$ ATP control (“0” time point), and ATP (1 mM final) was mixed with the reaction. Therefore, the final reactions contained 50 nM plasmid or kinetoplast DNA at 33 μ g/ml, 50 mM Tris (pH 7.7), 100 mM NaCl, 60 mM KOAc, 7.5 mM MgOAc, bovine serum albumin at 125 μ g/ml, 5% glycerol, 1 mM ATP, and the indicated final concentration of topoisomerase. Aliquots were removed at the indicated time points and quenched with an equal volume of 10% glycerol, 20 mM EDTA, 0.1% bromophenol blue, 0.1% xylene cyanol, and 0.2% SDS for electrophoresis in a 0.8% agarose gel. After running at 60 V for 12 hr the gels were stained in ethidium bromide, destained in water, and photographed over a UV transilluminator.

Gel Electrophoresis and Electroblothing. Protein samples were analyzed by SDS/PAGE and immunoblotting as described (29), with the exceptions that (i) there was no reductant in the sample loading buffer and (ii) immunoblotted bands were visualized using SuperSignal CL-HRP substrate system (Pierce). A Howtek Scanmaster 3+ with BioImage software was used to quantitate the relative protein concentrations in bands of Coomassie-stained gels.

Zonal Centrifugation of Proteins Through Preformed Glycerol Gradients. Glycerol solutions made up in 50 mM Tris·HCl, pH 7.5/200 mM NaCl/1 mM EDTA/1 mM EGTA were used to pour 15-ml, 10–40% linear glycerol gradients into 5/8 \times 4 inch centrifuge tubes (Beckman). Either 0.15 mg of topoII(C→A)zipGGC plus 0.2 mg of topoII(C→A)Ha in 1 mM diamide, or, as a control, 0.5 mg of thyroglobulin (Sigma, porcine type II with a native molecular mass of 660 kDa) plus 0.5 mg of topoII(C→A)Ha were loaded on top of the gradients. The samples were spun at 25,000 rpm for 60–65 hr at 4°C in an SW28 rotor (Beckman). Fractions of 700 μ L were removed from the bottom of the gradient. They were analyzed by SDS/PAGE followed either by Coomassie staining (for the controls) or electroblothing and immunostaining.

RESULTS

Design of the Tether. Determining the effect of linking the two protomers of a topoisomerase II dimer together will help define the mechanism of this enzyme. An effective cross-link would (i) be specific, (ii) form efficiently and (iii) be flexible enough for topoisomerase II to undergo its normal cycle of conformational changes. To achieve these goals, a chimeric protein consisting of the first 1334 amino acids of the yeast topoisomerase II and the last 33 amino acids of the yeast transcription factor GCN4, ending with two glycines and a cysteine was designed (see Fig. 1A). The carboxyl-terminal 33 amino acids of GCN4 dimerize by forming a leucine zipper; the dimerization of this peptide has been extensively studied (for review, see ref. 32). Rapid formation of intradimeric disulfide bonds occurs between these peptides engineered with Gly-Gly-Cys at the carboxyl termini (26). Therefore, if the two carboxyl terminal GCN4 sequences of the dimeric topoisomerase fusion protein form a leucine zipper, oxidation should produce a specific, disulfide-bonded cross-link.

For a separate series of experiments to be described elsewhere, all nine cysteines in the yeast topoisomerase II were changed to alanines [(topoII(C→A))] as shown in Fig. 1A. Although four of the cysteines are conserved among several eukaryotic type II DNA topoisomerases, none are completely conserved between the prokaryotic DNA gyrases and yeast topoisomerase II (11, 12). Therefore it was reasoned that they may not be essential for protein stability or catalytic activity. In fact, topoII(C→A) is at least half as active as the wild-type enzyme in supercoil relaxation and kinetoplast DNA decatenation (R. Knowlton and J.E.L., unpublished results). The chimeric proteins described in this paper have all of the cysteines in topoisomerase II replaced by alanines to avoid nonspecific disulfide bond formation, thiol–disulfide exchange reactions, and enzyme inactivation upon oxidation.

Although the carboxyl-terminal disulfide bond provides the covalent attachment between the two protomers of topoII(C→A)zipGGC, the leucine zipper may also provide significant intradimeric stability (26). Therefore, instead of only comparing the reduced and oxidized forms of topoII(C→A)zipGGC, a second chimeric protein, topoII(C→A)Ha, was used as a control protein (see Fig. 1A). In this protein the leucine zipper and carboxyl-terminal cysteine are replaced by the 10-amino acid Ha epitope.

The Cross-Link Forms Efficiently and Intradimerically. As shown in Fig. 1B, topoII(C→A)zipGGC can be efficiently cross-linked upon oxidation. TopoII(C→A)Ha (lanes 1 and 2) or topoII(C→A)zipGGC (lanes 3 and 4) were treated with 1 mM diamide and incubated as described (Fig. 1 legend) before denaturation and analysis by SDS/PAGE. Because the only cysteine in topoII(C→A)zipGGC is at the extreme carboxyl terminus, a disulfide bond that cross-links the protomers would form a tail-to-tail dimer that is expected to migrate as a linear polypeptide of \approx 316 kDa. The topoII(C→A)Ha migrates the distance expected for a denatured monomer of 155 kDa, whereas the majority (89%) of the topoII(C→A)zipGGC migrates as expected for a protein of twice the size. When the topoII(C→A)zipGGC was denatured in the presence of 20 mM dithiothreitol, all of the protein migrated as a single band at the position expected for a monomer of 158 kDa (data not shown). In addition, prior reaction of the enzyme with supercoiled DNA and ATP did not perturb the final cross-linking efficiency (compare lanes 3 and 4).

The results described above show that oxidation of topoII(C→A)zipGGC promotes the formation of a disulfide bond between two different protomers of topoisomerase II. They do not, however, address whether the leucine zipper and the disulfide bond form intradimerically, between the two protomers making up a topoisomerase II dimer, or instead form interdimerically between two or more topoisomerase dimers; either case would show the same result of cross-linked

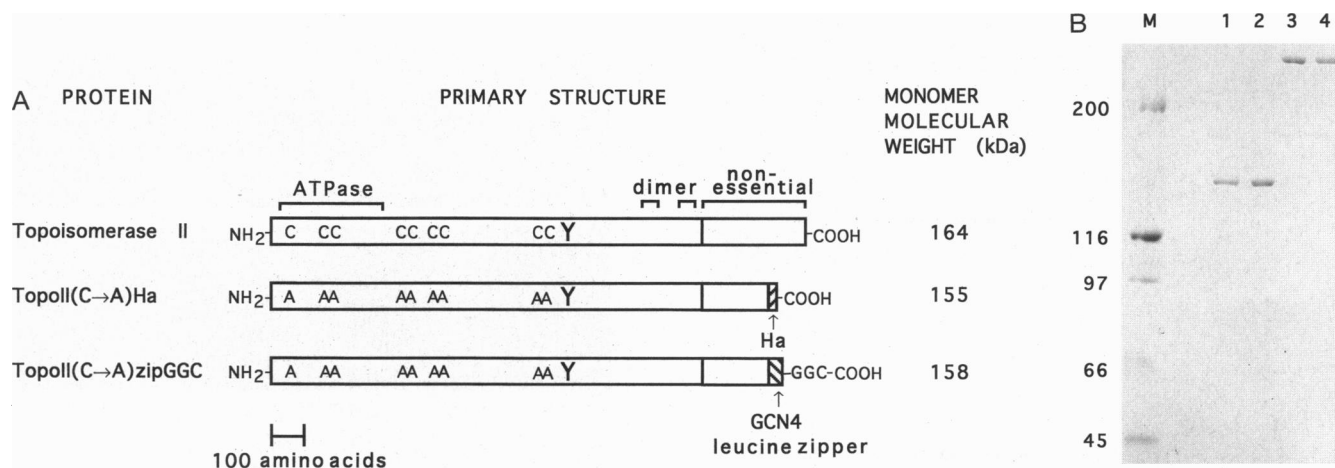

FIG. 1. (A) Schematic comparison of the overall primary structure of *S. cerevisiae* DNA topoisomerase II with that of the protein constructs used in this paper. The horizontal bars represent polypeptide sequences identical among the proteins, except where specifically indicated. Within the bars, "C" and "A" indicate the approximate positions of cysteines in the wild-type protein and replacement alanines in the altered constructs, respectively. In addition, the carboxyl-terminal 95 amino acids have been replaced with either the 10-amino acid Ha epitope [topoII(C→A)Ha] or the 33-amino acid GCN4 leucine zipper followed by Gly-Gly-Cys [topoII(C→A)zipGGC] in these constructs. The "Y" indicates the position of the active-site tyrosine Tyr-783 (24). The position of the indicated ATPase domain is assumed from sequence alignment with the *E. coli* DNA gyrase B (2) and the region of ATP binding seen in the crystal structure of its amino-terminal 43-kDa fragment (30), as well as mutagenesis studies of the yeast topoisomerase II (16). The "non-essential" region was determined by deletion mutagenesis of the *TOP2* gene and subsequent *in vitro* characterization of the resulting proteins (31). The predicted monomer molecular weights of these proteins are given. (B) Analysis of topoisomerase II tethering by disulfide bond formation between terminal cysteines of topoII(C→A)zipGGC by nonreducing SDS/PAGE. Protein [topoII(C→A)]Ha, lanes 1 and 2; topoII(C→A)zipGGC (lanes 3 and 4) at 500 nM in dialysis buffer/1 mM diamide was mixed in a 1:1 vol with 100 nM plasmid in reaction buffer lacking bovine serum albumin. The reactions were incubated for 10 min at 30°C either without (lanes 1 and 3) or with (lanes 2 and 4) ATP added to 1 mM. The molecular weights in kDa of protein markers run in the lane labeled M are shown at left.

dimers under denaturing conditions. However, only intradimerically disulfide-bonded topoII(C→A)zipGGC will have approximately the same native molecular weight as an uncross-linked topoisomerase dimer. By contrast, interdimerically cross-linked topoII(C→A)zipGGC will have at least twice the native molecular weight. These possibilities can be distinguished by determining the relative sedimentation coefficients of oxidized topoII(C→A)zipGGC and topoII(C→A)Ha. Analysis of fractions collected from a glycerol gradient containing a mixture of these proteins is shown in Fig. 2. The immunoblot shown in Fig. 2A was probed with anti-Ha antibodies to show the fractions containing the uncross-linked topoII(C→A)Ha. The blot in Fig. 2B was probed with polyclonal antitopoisomerase II antibodies and therefore shows the fractions containing both the cross-linked and uncross-linked proteins. These blots clearly show that both the cross-linked and uncross-linked proteins are in exactly the same fractions.

To show that these sedimentation conditions are capable of separating a topoisomerase dimer from a twice-larger protein, an identical gradient run simultaneously was loaded with a mixture of thyroglobulin (native molecular mass of 660 kDa) and topoII(C→A)Ha. The peak fractions containing thyroglobulin and topoII(C→A)Ha from this gradient are indicated in Fig. 2 by "th" and "to," respectively. These sedimentation conditions were clearly sufficient for separating large proteins whose native molecular weights differ by a factor of two. In addition, a similar mixture of topoII(C→A)zipGGC and topoII(C→A)Ha was analyzed on a Superdex 200 gel filtration column; again, the two proteins eluted in identical fractions (data not shown). Taken together, these data show that the leucine zipper and disulfide bond of topoII(C→A)zipGGC formed intradimerically.

The Cross-Linked Topoisomerase II Is Catalytically Active in DNA Transport. To test whether the covalent tether interferes with the enzyme's ability to catalyze DNA transport, supercoil relaxation and kinetoplast decatenation assays were performed. Because both the carboxyl-terminal disulfide and the leucine zipper are involved in the cross-link, the activity of topoII(C→A)zipGGC was compared to that of an enzyme

lacking both aspects of the link, topoII(C→A)Ha. Yeast DNA topoisomerase II is a processive enzyme in the relaxation of supercoils; when the molar ratio of plasmid substrate to enzyme is high, the rate of the overall reaction is limited by the rate of relaxed plasmid dissociation (15, 16). Therefore, so that the assay more accurately reflects the rate of DNA transport, or linking number change, approximately equimolar amounts of enzyme and plasmid were used. Assuming a specific linking difference (σ) of -0.06 , and a size of 2.9 kb, approximately eight transport events must be catalyzed to fully relax each plasmid substrate. A relaxation assay performed in this way is also an active site titration assay. Purified wild-type yeast topoisomerase II was shown to be 30–50% active by such an assay (16). Approximately the same is found for the cysteineless fusion proteins (Fig. 3).

The results of the supercoil relaxation assay are shown in Fig. 3. The same proteins that were analyzed by SDS/PAGE in Fig. 1b were used for this assay; the assays of uncross-linked topoII(C→A)Ha are in *a* and comparable assays for the cross-linked protein are in *b*. Three different concentrations of enzyme were compared, and in each case there was no significant difference in activity seen between the uncross-linked and cross-linked enzymes. The first lane for each reaction time course (labeled "0") shows the results of incubating a reaction aliquot in the absence of ATP for 10 min. The ATP dependence of the reactions shows that type II DNA topoisomerase activity is being measured, and not contaminating topoisomerase I activity. Additionally, topoisomerase II mutants known to be inactive have been expressed, purified, and shown to have no activity in the same assay (16).

To further insure that the cross-linked enzyme is an active type II DNA topoisomerase, it was also assayed for its ability to decatenate interlinked kinetoplast DNA circles. A comparison of the decatenation activities of topoII(C→A)Ha, topoII(C→A)zipGGC (oxidized), and topoII(C→A)zipGGC (reduced) is shown in Fig. 4. Again, there is no significant difference in activity detected between the enzymes. Indeed, there is certainly not the 10-fold difference in activity expected

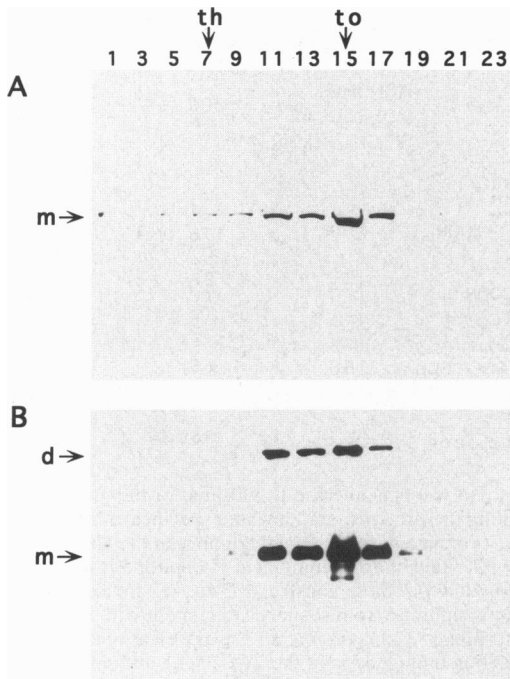

FIG. 2. Immunostaining of fractions from glycerol gradient analysis of native topoII(C→A)Ha and topoII(C→A)zipGGC. TopoII(C→A)Ha (0.2 mg) and topoII(C→A)zipGGC (0.15 mg) were mixed together with 1 mM diamide on ice for 20 min. This sample was analyzed by centrifugation through a glycerol gradient as described. Nitrocellulose blots from nonreducing SDS/PAGE analysis of fractions taken from the bottom of the gradient were probed with either anti-Ha monoclonal antibody (12CA5) (*A*), or polyclonal antitopoisomerase II antibody (*B*). The approximate positions of monomer (*m*) and cross-linked dimer (*d*) bands, based on molecular-weight markers (not visible here), are indicated. The fractions containing peak concentrations of thyroglobulin (660 kDa, "th") and topoII(C→A)Ha ("to") in an identical control gradient are indicated by arrows above fraction numbers.

were only the small fraction of nondisulfide-bonded topoII(C→A)zipGGC responsible for all of the activity.

DISCUSSION

The two protomers of yeast topoisomerase II can be flexibly tethered without disrupting the enzyme's ability to catalyze DNA transport. Because the structure of the tethered enzyme is unknown, one must be cautious in interpreting the mechanistic implications of this finding. Three simplified reaction models that are consistent with the present finding are shown in Fig. 5. These models are also based on several previous observations: (*i*) the ATPase domain of *Escherichia coli* gyrase B, which is homologous to the amino-terminal domain of eukaryotic topoisomerase II, dimerizes in the presence of a nonhydrolyzable ATP analog (30, 33), (*ii*) upon binding ATP, the eukaryotic topoisomerase II dimer clamps down, topologically trapping a prebound circular DNA (17, 18) and, (*iii*) in the presence of a nonhydrolyzable ATP analog, topoisomerase II can decatenate two linked DNA circles leaving one of the two circles topologically trapped inside the enzyme (20).

The general shape of the enzyme was taken from three-dimensional structural data (kindly shared before publication by J. M. Berger, J. C. Wang, and S. Harrison) and electron micrograph results of R. Hancock, P. Oudet and P. Benedetti as adapted (3). The tethered topoisomerase II molecule shown in Fig. 5 is represented as a dimer of three globular domains, and a fourth, potentially unfolded domain, followed by the leucine zipper and disulfide cross-link. This fourth domain consists of the approximately 160 amino acids of the non-

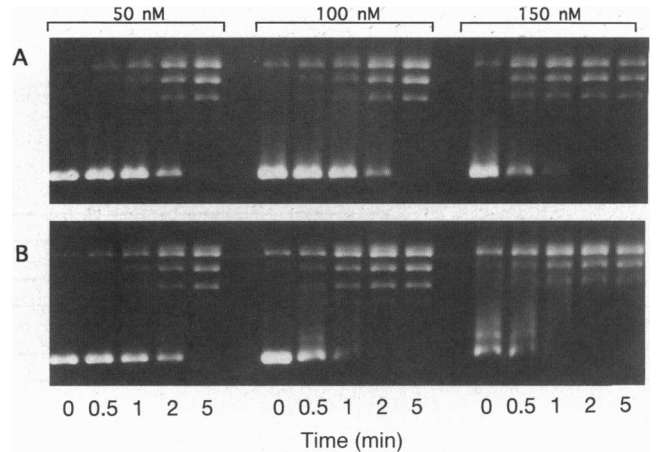

FIG. 3. DNA supercoil relaxation activity of topoII(C→A)Ha and topoII(C→A)zipGGC. Above each time course shown is the final reaction concentration of either oxidized topoII(C→A)Ha (*A*) or topoII(C→A)zipGGC (*B*). Aliquots of reactions quenched at the time points indicated were analyzed by agarose gel electrophoresis. Under the electrophoresis conditions used, the supercoiled substrate DNA migrates most rapidly as a single band, and the reaction products form a ladder of bands representing a thermal distribution of relaxed covalently closed circles.

essential, nonconserved region of the topoisomerase remaining in the chimeric cross-linked protein. The two DNA segments shown are labeled "G" for the gated and "T" for the transported regions of either the same or different DNA molecules, as suggested previously (17).

In model *a*, a potential "one-gate" model, the T segment is the first DNA to bind in the enzyme cleft, followed by binding and cleavage of the G segment (*i*). Upon binding ATP, the enzyme undergoes a conformational change that simultaneously drives the T segment through the gate in the G segment and dimerizes the amino termini of the enzyme (*ii*). Upon ATP hydrolysis, the amino termini again separate, allowing the religated G segment either to dissociate or become the T segment for a second round of reaction (*iii*). One observation that is potentially inconsistent with this model is that the first DNA to bind to the topoisomerase is the cleaved DNA (17). However, this observation was only made under low salt reaction conditions such that this limitation may not apply

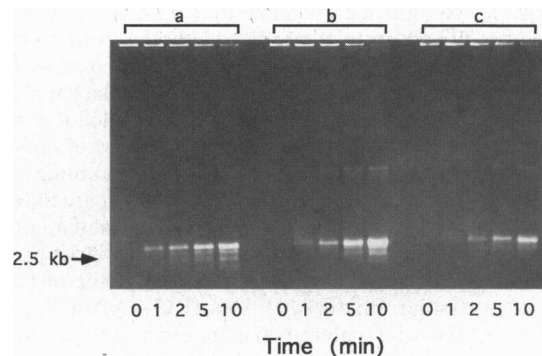

FIG. 4. Kinetoplast DNA decatenation activity of topoII(C→A)Ha and topoII(C→A)zipGGC. Reactions were done as described with 25 nM of diamide-treated topoII(C→A)Ha (lanes *a*), topoII(C→A)zipGGC (lanes *b*), or topoII(C→A)zipGGC with 20 mM dithiothreitol (lanes *c*). Aliquots of the reactions were quenched at the indicated time points and analyzed by agarose gel electrophoresis. For the "0" time points, aliquots of the reaction mixes were removed before addition of ATP and incubated for 15 min before quenching. The kinetoplast DNA network used as the substrate does not migrate into the gel and can be seen accumulated in the wells. The major products of this reaction are relaxed DNA circles of ≈ 2.5 kb.

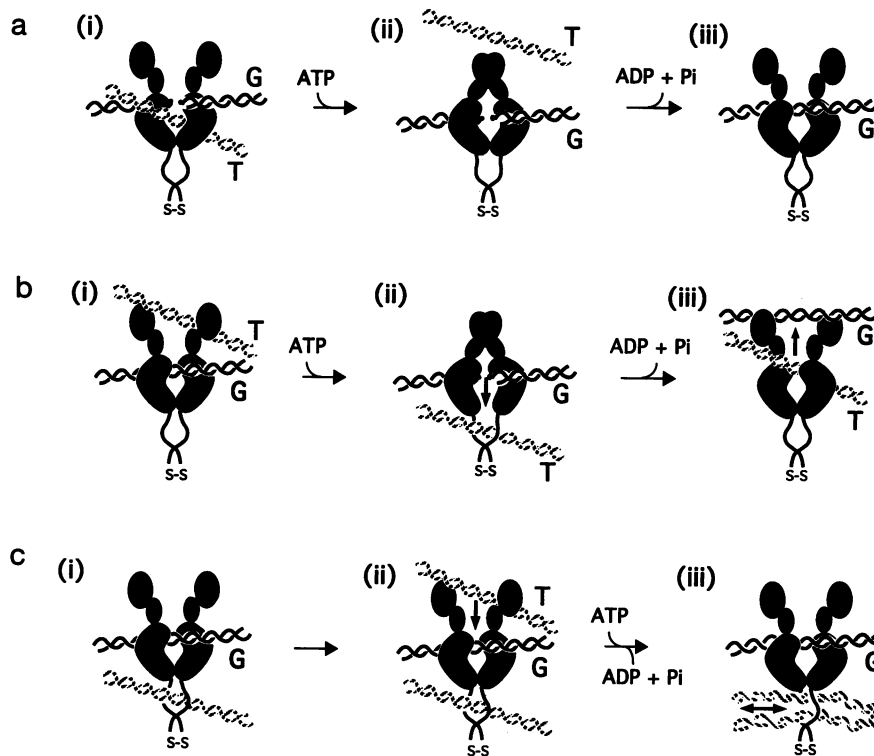

FIG. 5. Simplified models of how tethered topoisomerase II could catalyze ATP-dependent DNA double-strand passage. See text for description. S-S, disulfide cross-link.

under reaction conditions in which the enzyme is normally catalytically active.

Model **b** is a "two-gate model," as previously described (20, 21, 34), in which the T segment is transported through both the gate in the G segment and through the carboxyl-terminal dimer interface (the second gate) (ii). The T segment would normally be released from the enzyme at this point, but it is topologically trapped within the cross-linked fusion protein. For this cross-linked enzyme to be catalytically active, it must be able to release the reaction products, potentially in an artificial fashion, back through the amino termini of the enzyme (iii). This release may occur upon ATP hydrolysis or may require additional reaction cycles. However, the cross-linked enzyme is no slower in multiple turnover supercoil relaxation or kinetoplast decatenation than the uncross-linked enzyme. This result indicates that if the cross-linked enzyme requires additional steps in its reaction pathway to release DNA, they must be fast enough not to limit the overall steady-state reaction rate.

Model **c** shows a second potential way in which the tethered enzyme could function in a two-gate mechanism. In this model, a single turnover of DNA transport would leave the plasmid substrate trapped within the tethered enzyme (i). If the enzyme-DNA complex now binds a second segment of DNA from the same molecule as the first T segment (ii), and transports this second segment through the same G segment (iii), the DNA circle is now topologically free from the enzyme. The same mechanism could also apply for kinetoplast DNA decatenation. Further studies are required to distinguish between these three possible mechanisms.

Fusion proteins composed of leucine zippers and polypeptides of interest were previously made to alter quaternary structure (35, 36), study homo- versus heterodimerization (37), and analyze sequence requirements for coiled-coil formation *in vivo* (38). Site-specific incorporation of cysteines was used in many studies to produce covalent cross-links between polypeptides by oxidative disulfide bond formation (see ref. 39) for a representative example). This work reports combining these two approaches to specifically and covalently cross-

link the two protomers of a dimeric fusion protein together. Besides mechanistic studies, this cross-linked topoisomerase-leucine zipper fusion protein may also be useful in creating and stabilizing heterodimeric enzymes in which one protomer is wild type and the other is mutant; such heterodimers are very useful for studies of allostery (18). In addition, this tethered enzyme may help solve the question of whether low levels of illegitimate DNA recombination postulated to be catalyzed by topoisomerase II occurs by a subunit exchange mechanism (40).

The topoisomerase II derivatives used in this paper do not have any of the nine naturally occurring cysteines. There was no previous indication that any of the cysteines would be required for catalysis; nevertheless, experiments presented here provide direct evidence that DNA topoisomerase II does not require any cysteines for its catalytic activity.

I thank Danielle Taysom for technical assistance and Thomas Alber, Wai Mun Huang, James Berger, and James C. Wang for discussions. This work was supported by the Lucille P. Markey Charitable Grant for Biophysics (M. C. Rechsteiner, P.I.) and a grant from the U.S. Public Health Service (GM 51194).

1. Wigley, D. B. (1995) *Annu. Rev. Biophys. Biomol. Struct.* **24**, 185-208.
2. Hsieh, T. (1990) in *DNA Topology and Its Biological Implications*, eds. Cozzarelli, N. R. & Wang, J. C. (Cold Spring Harbor Lab. Press, Plainview, NY), pp. 1-21.
3. Roca, J. (1995) *Trends Biochem. Sci.* **20**, 156-160.
4. Wang, J. C. (1991) *J. Biol. Chem.* **266**, 6659-6662.
5. Holm, C. (1994) *Cell* **77**, 955-957.
6. Rose, D. & Holm, C. (1993) *Mol. Cell. Biol.* **13**, 3445-3455.
7. Uemura, T., Ohkura, H., Adachi, Y., Morino, K., Shiozaki, K. & Yanagida, M. (1987) *Cell* **50**, 917-925.
8. Hirano, T. & Mitchison, T. J. (1993) *J. Cell Biol.* **120**, 601-612.
9. Froelich-Ammon, S. J. & Osheroff, N. (1995) *J. Biol. Chem.* **270**, 21429-21432.
10. Liu, L. F., ed. (1994) *DNA Topoisomerases: Topoisomerase-Targeting Drugs*, Advances in Pharmacology (Academic, San Diego), Vol. 29B.

11. Caron, P. R. & Wang, J. C. (1994) in *DNA Topoisomerases: Topoisomerase-Targeting Drugs*, ed. Liu, L. F. (Academic, San Diego), pp. 271–297.
12. Huang, W. M. (1994) in *DNA Topoisomerases: Topoisomerase-Targeting Drugs*, ed. Liu, L. F. (Academic, San Diego), pp. 201–225.
13. Gale, K. C. & Osheroff, N. (1992) *J. Biol. Chem.* **267**, 12090–12097.
14. Zechiedrich, E. L., Christiansen, K., Andersen, A. H., Westergaard, O. & Osheroff, N. (1989) *Biochemistry* **28**, 6229–6236.
15. Osheroff, N., Shelton, E. R. & Brutlag, D. L. (1983) *J. Biol. Chem.* **258**, 9536–9543.
16. Lindsley, J. E. & Wang, J. C. (1993) *J. Biol. Chem.* **268**, 8096–8104.
17. Roca, J. & Wang, J. C. (1992) *Cell* **71**, 833–840.
18. Lindsley, J. E. & Wang, J. C. (1993) *Nature (London)* **361**, 749–750.
19. Morrison, A., Brown, P. O., Kreuzer, K. N., Otter, R., Gerrard, S. P. & Cozzarelli, N. R. (1980) in *Mechanistic Studies of DNA Replication and Genetic Recombination*, ed. Alberts, B. (Academic, New York), pp. 785–807.
20. Roca, J. & Wang, J. C. (1994) *Cell* **77**, 609–616.
21. Orphanides, G. & Maxwell, A. (1994) *Curr. Biol.* **4**, 1006–1009.
22. Lima, C. D. & Mondragon, A. (1994) *Structure* **2**, 559–560.
23. Englund, P. T. (1978) *Cell* **14**, 157–168.
24. Worland, S. T. & Wang, J. C. (1989) *J. Biol. Chem.* **264**, 4412–4416.
25. Kolodziej, P. A. & Young, R. A. (1991) *Methods Enzymol.* **194**, 508–519.
26. O'Shea, E. K., Rutkowski, R. & Kim, R. S. (1989) *Science* **243**, 538–542.
27. Wasserman, R. A. & Wang, J. C. (1994) *J. Biol. Chem.* **269**, 20943–20951.
28. Kosower, N. S. & Kosower, E. M. (1987) *Methods Enzymol.* **143**, 264–270.
29. Lindsley, J. E. & Wang, J. C. (1991) *Proc. Natl. Acad. Sci. USA* **88**, 10485–10489.
30. Wigley, D. B., Davies, G. J., Dodson, E. J., Maxwell, A. & Dodson, G. (1991) *Nature (London)* **351**, 624–629.
31. Caron, P. R., Watt, P. & Wang, J. C. (1994) *Mol. Cell. Biol.* **14**, 3197–3207.
32. Cohen, C. & Parry, D. A. D. (1994) *Science* **263**, 488–489.
33. Ali, J. A., Jackson, A. P., Howells, A. J. & Maxwell, A. (1993) *Biochemistry* **32**, 2717–2724.
34. Wang, J. C. (1982) *Sci. Am.* **247**, 94–109.
35. Blondel, A. & Bedouelle, H. (1991) *Protein Eng.* **4**, 457–461.
36. Pack, P., Muller, K., Zahn, R. & Pluckthun, A. (1995) *J. Mol. Biol.* **246**, 28–34.
37. Schmidt-Dorr, T., Oertel-Buchheit, P., Pernelle, C., Bracco, L., Schnarr, M. & Granger-Schnarr, M. (1991) *Biochemistry* **30**, 9657–9664.
38. Hu, J. C., O'Shea, E. K., Kim, P. S. & Sauer, R. T. (1990) *Science* **250**, 1400–1403.
39. Milligan, D. L. & Koshland, D. E., Jr. (1988) *J. Biol. Chem.* **263**, 6268–6275.
40. Bae, Y., Kawaski, I., Ikeda, H. & Liu, L. F. (1988) *Proc. Natl. Acad. Sci. USA* **85**, 2076–2080.