

Published in final edited form as:

*J Adolesc.* 2015 January ; 0: 1–4. doi:10.1016/j.adolescence.2014.10.008.

## Brief Report: Preliminary evidence that co-rumination fosters adolescents' depression risk by increasing rumination

Lindsey B. Stone<sup>1</sup> and Brandon E. Gibb<sup>2</sup>

<sup>1</sup>Department of Psychiatry, University of Pittsburgh School of Medicine, Pittsburgh, PA, United States of America

<sup>2</sup>Department of Psychology, Binghamton University (SUNY), Binghamton, NY, United States of America

### Abstract

Mounting research shows that the tendency to co-ruminate with peers regarding ongoing problems increases adolescents' depression risk; however, the means by which this interpersonal process fosters risk has not been identified. This said, theorists have proposed that co-rumination increases depression risk, in part, by increasing one's tendency to ruminate when alone. We tested this hypothesis in a study of 201 high-school freshmen who completed two assessments, six months apart. Supporting the proposed model, co-rumination predicted prospective increases in rumination and rumination predicted increases in depressive symptoms. The direct effect of co-rumination on depressive symptom change was not significant. Results indicate that co-rumination with friends may serve to increase rumination, which in turn increases depression risk.

### Keywords

co-rumination; depression; rumination; peer relationships; adolescence

---

Co-rumination involves the tendency to engage with peers in extensive negatively focused discussion, by rehashing one's reactions to ongoing problems (Rose, 2002). Despite the social benefits of increasing friendship quality (Rose, 2002; Rose, Carlson & Waller, 2007), there is growing evidence that co-rumination increases adolescents' risk for future depressive symptoms and diagnoses (Hankin, Stone, & Wright, 2010; Stone, Hankin, Gibb, & Abela, 2011). Although the precise mechanisms by which co-rumination increases depression risk are not known, Rose (2002) hypothesized that co-rumination fosters youths' risk for emotional distress by reinforcing the tendency to ruminate on their own. There is

---

© 2014 Elsevier Ltd on behalf of The Foundation for Professionals in Services for Adolescents. All rights reserved.

Correspondence: Lindsey B. Stone, Ph.D. University of Pittsburgh Medical School, Western Psychiatric Institute and Clinic, 3811 O'Hara Street, Pittsburgh, PA 15213, Stonelb@upmc.edu, Phone: (412) 648-9438, Fax: (412) 383-5426. Brandon E. Gibb, Binghamton University (SUNY), Department of Psychology, Binghamton, NY 13902-6000, Bgibb@binghamton.edu.

**Publisher's Disclaimer:** This is a PDF file of an unedited manuscript that has been accepted for publication. As a service to our customers we are providing this early version of the manuscript. The manuscript will undergo copyediting, typesetting, and review of the resulting proof before it is published in its final citable form. Please note that during the production process errors may be discovered which could affect the content, and all legal disclaimers that apply to the journal pertain.

preliminary cross-sectional support for this hypothesis (Rose, 2002) but it has not yet been tested prospectively.

The goal of this study was to provide a prospective test of Rose's (2002) mediation hypothesis. Focusing on a sample of high school freshmen assessed twice, 6 months apart, we predicted that initial levels of co-rumination would predict prospective changes in rumination over the follow-up and that initial levels of rumination would predict prospective changes in adolescents' depressive symptoms. Given some evidence that rumination may predict prospective increases in co-rumination (Jose, Wilkins & Spindel, 2012), we also tested for potential bi-directional influences between co-rumination and rumination.

Finally, co-rumination has been emphasized in adolescent girls' depression risk since it is more common of female friendships (e.g., Rose, 2002; Hankin et al., 2010). However, the majority of results show that, despite being more common in girls, both girls and boys who co-ruminate with peers are at heightened depression risk (Hankin et al., 2010; Stone, Uhrlass, & Gibb, 2010; Stone et al., 2011; but see also Rose et al., 2007). Therefore, we tested for gender moderation, but did not anticipate significant gender differences in the magnitudes of the associations between the model variables.

## Method

### Participants and procedure

Freshmen were recruited from a local high school. Of 336 incoming students, 245 parental consent forms were completed, with 218 granting permission. Several students declined to participate or were absent, resulting in 201 participants: 51% female, 84% Caucasian and the average age was 14.16 ( $SD = .44$ ). The follow-up assessment was completed by 192 (95%) students. Assessments were administered six months apart in group setting. Afterwards participants were entered into a lottery for a chance to win \$50–100 gift cards.

### Measures

The Children's Depression Inventory (CDI; Kovacs, 1981) was used to assess depressive symptom levels. Consistent with school-based research, the suicide item was omitted ( $\alpha$ : T1=.88 and T2=.89).

The Co-Rumination Questionnaire (CRQ; Rose, 2002) assessed the extent to which participants co-ruminate with their closest friend. Participants responded to 27 items using a 5-point Likert scale ranging from "Not at all true" (1) to "Really true" (5). For example, "If one of us has a problem, we will spend our time together talking about it, no matter what else we could do instead." Co-rumination was calculated by averaging participants' ratings across the 27 items, ( $\alpha$ : T1=.97 and T2=.98)

The five-item brooding subscale of the Ruminative Responses Scale (RRS; Nolen-Hoeksema & Morrow, 1991; Treynor, Gonzalez, & Nolen-Hoeksema, 2003) was used to assess levels of brooding rumination, ( $\alpha$ : T1=.86 and T2=.80). For example, "When I am sad I think 'Why do I always react this way?'"

## Results

Given the presence of missing data at each assessment (6–7%), we examined if data were missing at random to justify data imputation methods for estimating missing values (Schafer & Graham, 2002). Little's missing completely at random (MCAR) test was non-significant,  $\chi^2(892) = 906.57, p = .36$ , supporting the imputation of missing values (Little & Rubin, 1987). Thus, maximum likelihood estimates of missing data were created and used in all analyses (Schafer & Graham, 2002). Descriptive statistics and correlations are presented in Table 1. Associations between co-rumination, rumination, and depressive symptoms were significant concurrently and across assessments. Girls exhibited higher levels of co-rumination than boys, but there was no gender difference in rumination or depressive symptoms at either assessment.

We used path analysis to test our model, following the steps outlined by Cole and Maxwell (2003) in AMOS (Arbuckle, 2010). For an indirect pathway between co-rumination and depressive symptoms via rumination to be supported, (i) the proposed model had to provide a good fit to the data compared to a fully saturated model, and (ii) the indirect pathway (product of the  $\alpha\beta$  coefficients) must be significant (MacKinnon et al., 2002). In this two wave study the indirect path was as follows: co-rumination must predict a significant increase in rumination ( $\alpha = T1CoRum \rightarrow T2Rum$ ) covarying for baseline rumination ( $T1Rum \rightarrow T2Rum$ ), and rumination must predict a significant increase in depressive symptoms: ( $\beta = T1Rum \rightarrow T2CDI$ ) covarying for baseline depression ( $T1CDI \rightarrow T2CDI$ ; cf. Cole & Maxwell, 2003). Given the significant concurrent correlations, all baseline predictors were allowed to correlate, as were the error terms of the endogenous variables.

The fully saturated model is presented in Figure 1. All T1 variables were significantly related to their T2 counterparts. In addition, consistent with our indirect model, T1 co-rumination predicted residual change in rumination and T1 rumination predicted residual change in depressive symptoms. None of the reciprocal effects were significant. Figure 2 presents our predicted indirect pathway model, which provided an excellent fit to the data: CFI = 1.00, SRMR = .03, RMSEA = .04 (Hu & Bentler, 1999), and did not fit significantly worse than the fully-saturated model,  $\chi^2(3) = 4.27, p = .23$ . Each path in Figure 2 was significant (at  $p < .05$ ) except for the direct path between T1 co-rumination and T2 depressive symptoms and one covariance between error terms. We then conducted a Sobel test of the indirect ( $\alpha\beta$ ) path following the procedures outlined by MacKinnon et al. (2002). This indirect path was significant,  $Z = 1.60, p < .05$ . Removing the direct path ( $T1CDI \rightarrow T2CDI$ ) did not worsen model fit,  $\chi^2(1) = .52, p = .47$ , or alter the significance of the indirect ( $\alpha\beta$ ) path.<sup>1</sup>

Finally, we conducted a multi-group comparison to determine if the model paths were moderated by gender. Specifically, we compared a model in which the magnitudes of the paths were allowed to differ for boys and girls to one in which they were constrained to be equal. The constrained model provided a satisfactory fit to the data,  $\chi^2(20) = 22.76, p = .36$ ,

<sup>1</sup>A linear regression testing the direct effect of co-rumination on depressive symptom change (covarying only for baseline symptoms) was also not significant,  $t(198) = 1.03, p = .31, sr = .05$ .

CFI=.99, SRMR=.04, and did not fit significantly worse than the model in which the paths were allowed to vary,  $\chi^2(10)= 5.45, p = .86$ , indicating that the associations did not significantly differ between girls and boys.

## Discussion

The current study provides the first prospective test of whether co-rumination fosters youths' depression risk by increasing rumination (Rose, 2002). Co-rumination did not directly predict depressive symptom changes, but indirectly increased depressive symptoms by increasing adolescents' tendency to ruminate. Perhaps importantly, the reverse was not true; rumination did not predict prospective increases in the tendency to co-ruminate with one's friends. The results add to a growing body of research suggesting co-rumination is not merely a symptom of internal rumination, but actually serves to increase ruminative tendency. With rumination an established predictor of youths' depression (Nolen-Hoeksema, Wisco & Lyumbomirski, 2008), this strengthens the need to target co-rumination in adolescent depression interventions.

We should note that the indirect pathway model fit equally well for girls and boys in our sample. This is consistent with prior work showing that when present, co-rumination is equally maladaptive for both girls and boys (Hankin et al., 2010; Stone et al., 2010, 2011). Results also replicated the gender difference in co-rumination; however, in contrast to previous research, we did not observe a gender difference in rumination or depressive symptoms.

A key strength of this study was the prospective design and the focus on evaluating potential reciprocal relations between co-rumination and rumination. However, several limitations should also be noted. First, a full longitudinal mediation model would test prospective changes across three or more assessments. Second, the study focused exclusively on high school freshmen and a larger age range would enable analysis of developmental differences in the links among these variables, which may be informative given that co-rumination emerges across late-childhood into adolescence (Hankin et al., 2010; Rose, 2002) coinciding with the increase in depression onsets (Hankin et al., 1998). Finally, we assessed co-rumination with participants' 'closest or best friend', but did not constrain analyses to stable, reciprocated dyads. The link between friendship stability and co-rumination has not been assessed and it is possible the effects of co-rumination differ between reciprocated vs. non-reciprocated friendships. Future studies should explore these possibilities.

In summary, the current results provide important information about the temporal relation between co-rumination and rumination and suggest that co-rumination with one's friends may increase depression risk, in part, by increasing the tendency to ruminate by oneself outside of these discussions. At a broader level, these findings demonstrate how interpersonal processes that are socially rewarding (via validation, support, and friendship intimacy) may impact intrapersonal risk factors for depression, providing additional potential targets for intervention.

## Acknowledgments

This project was supported by National Institute of Mental Health grant F31 MH093019 awarded to Lindsey B. Stone and National Institute of Child Health and Human Development grant R01 HD057066 awarded to Brandon E. Gibb.

## References

- Arbuckle, JL. IBM SPSS AMOS™ 19 User's Guide. Amos Development Corporation; 2010.
- Cole DA, Maxwell SE. Testing mediational models with longitudinal data: Questions and tips in the use of structural equation modeling. *Journal of Abnormal Psychology*. 2003; 112:558–577. [PubMed: 14674869]
- Hankin BL, Abramson LY, Moffitt TE, Silva PA, McGee R, Angell KE. Development of depression from preadolescence to young adulthood: emerging gender differences in a 10-year longitudinal study. *Journal of Abnormal Psychology*. 1998; 107:128. [PubMed: 9505045]
- Hankin BL, Stone LB, Wright PA. Co-rumination, interpersonal stress generation, and internalizing symptoms: Accumulating effects and transactional influences in a multi-wave study of adolescents. *Development and Psychopathology*. 2010; 22:217–235. [PubMed: 20102657]
- Hu LT, Bentler PM. Cutoff criteria for fit indexes in covariance structure analysis: Conventional criteria versus new alternatives. *Structural Equation Modeling: A Multidisciplinary Journal*. 1999; 6(1):1–55.
- Jose PE, Wilkins H, Spindelov JS. Does social anxiety predict rumination and co-rumination among adolescents? *Journal of Clinical Child & Adolescent Psychology*. 2012; 41(1):86–91. [PubMed: 22233248]
- Little, RJA.; Rubin, DB. *Statistical analysis with missing data*. New York, NY, US: J. Wiley & Sons; 1987.
- Kovacs M. Rating scales to assess depression in school-aged children. *Acta Paedopsychiatrica*. 1981; 46:305–315. [PubMed: 7025571]
- MacKinnon DP, Lockwood CM, Hoffman JM, West SG, Sheets V. A comparison of methods to test mediation and other intervening variable effects. *Psychological Methods*. 2002; 7:83–104. [PubMed: 11928892]
- Nolen-Hoeksema S, Morrow J. A prospective study of depression and posttraumatic stress symptoms after a natural disaster: the 1989 Loma Prieta Earthquake. *Journal of personality and social psychology*. 1991; 61(1):115. [PubMed: 1890582]
- Nolen-Hoeksema S, Wisco BE, Lyumbomirski S. Rethinking Rumination. *Perspectives on Psychological Science*. 2008; 3:400–424.
- Rose A. Co-rumination in the friendships of boys and girls. *Child Development*. 2002; 73:1830–1843. [PubMed: 12487497]
- Rose AJ, Carlson W, Waller EM. Prospective associations of Co-rumination with friendship and emotional adjustment: Considering the socioemotional trade-offs of co-rumination. *Developmental Psychology*. 2007; 43(4):1019–1031. [PubMed: 17605532]
- Schafer JL, Graham JW. Missing data: Our view of the state of the art. *Psychological Methods*. 2002; 7:147–177. [PubMed: 12090408]
- Stone LB, Hankin BL, Gibb BE, Abela JRZ. Co-rumination predicts the onset of depressive disorders during adolescence. *Journal of Abnormal Psychology*. 2011; 120:752–757. [PubMed: 21500877]
- Stone LB, Uhrlass DJ, Gibb BE. Co-rumination and lifetime history of depressive disorders in children. *Journal of Clinical Child and Adolescent Psychology*. 2010; 39:597–602. [PubMed: 20589570]
- Treynor W, Gonzalez R, Nolen-Hoeksema S. Rumination reconsidered: A psychometric analysis. *Cognitive Therapy and Research*. 2003; 27:247–259.

### Highlights

- Mounting evidence supports co-rumination is a risk factor for depression in youth.
- Yet little is known about precise mechanisms by which co-rumination fosters risk.
- Co-rumination was found to increase depressive symptoms by increasing rumination.
- Findings help to bridge interpersonal and intrapersonal models of depression risk.

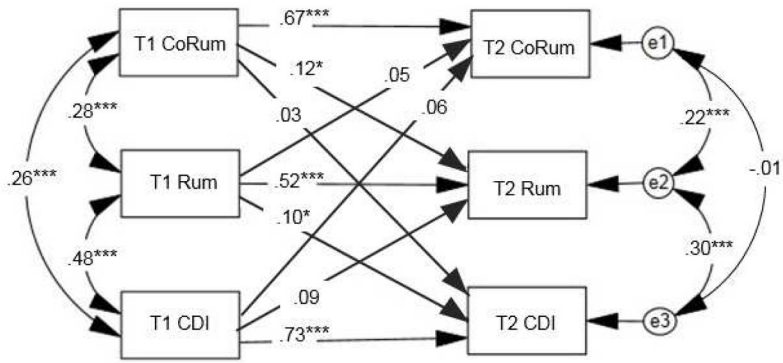

**Figure 1.**

Fully saturated model

Note: Values represent standardized betas: \* $p < .05$ , \*\*\* $p < .001$

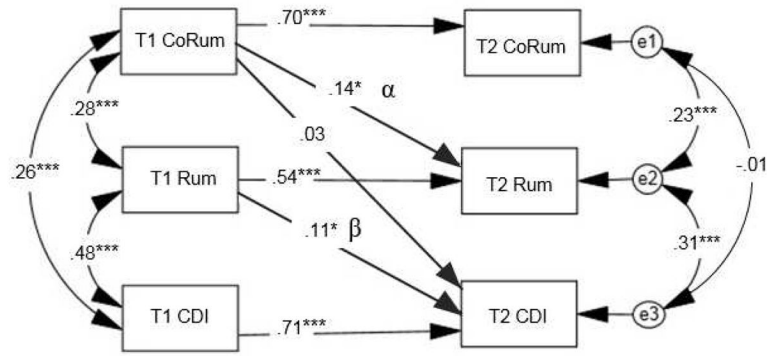

**Figure 2.** Rumination acts as an intervening variable between baseline co-rumination and depressive symptom changes. Values represent standardized betas. \* $p < .05$ , \*\*\* $p < .001$



Table 1

Bivariate associations and descriptive statistics

	1	2	3	4	5	6	Mean	SD
1 T1 CDI	—						7.60	6.96
2 T1 CoRum	.26***	—					2.38	0.90
3 T1 Rum	.48***	.28***	—				10.70	4.10
4 T2 CDI	.78***	.25***	.46***	—			7.71	6.95
5 T2 CoRum	.25***	.70***	.26***	.23***	—		2.45	0.97
6 T2 Rum	.37***	.29***	.59***	.48***	.37***	—	10.75	3.76
7 Gender	-.01	.35***	.06	-.05	.25***	.11	—	—

Note: T1, T2= Time 1 and Time 2 respectively. CDI= Children's Depression Inventory. CoRum= Co-Rumination Questionnaire. Rum= Ruminative Response Styles, Brooding Subscale. Gender: Boys = 0, Girls = 1.

\*\*\*  
p .001